

Exhibit No.:  
Issues: GMO Capacity  
Iatan 2 allocation  
Witness: Lena M. Mantle  
Sponsoring Party: MO PSC Staff  
Type of Exhibit: Surrebuttal Testimony  
File No.: ER-2010-0356  
Date Testimony Prepared: January 12, 2010

**MISSOURI PUBLIC SERVICE COMMISSION**

**UTILITY OPERATIONS DIVISION**

**SURREBUTTAL TESTIMONY**

**OF**

**LENA M. MANTLE**

**KCP&L GREATER MISSOURI OPERATIONS COMPANY**

**FILE NO. ER-2010-0356**

*Jefferson City, Missouri  
January 2011*

**\*\*Denotes Highly Confidential Information\*\***

**NP**

**BEFORE THE PUBLIC SERVICE COMMISSION  
OF THE STATE OF MISSOURI**

In the Matter of the Application of )  
KCP&L Greater Missouri Operations )  
Company for Approval to Make Certain )  
Changes in its Charges for Electric )  
Service )

File No.: ER-2010-0356

**AFFIDAVIT OF LENA M. MANTLE**

STATE OF MISSOURI    )  
                                  ) ss  
COUNTY OF COLE    )

Lena M. Mantle, of lawful age, on her oath states: that she has participated in the preparation of the following Surrebuttal Testimony in question and answer form, consisting of 15 pages of Surrebuttal Testimony to be presented in the above case, that the answers in the following Surrebuttal Testimony were given by her; that she has knowledge of the matters set forth in such answers; and that such matters are true to the best of her knowledge and belief.

  
\_\_\_\_\_  
Lena M. Mantle

Subscribed and sworn to before me this 12<sup>th</sup> day of January, 2011.

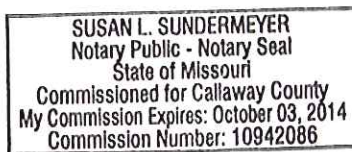

  
\_\_\_\_\_  
Notary Public

**Table of Contents**

**SURREBUTTAL TESTIMONY**

**OF**

**LENA M. MANTLE**

**KCP&L GREATER MISSOURI OPERATIONS COMPANY**

**FILE NO. ER-2010-0356**

**PHANTOM TURBINES/CROSSROADS ENERGY CENTER ..... 2**

**ALLOCATION OF IATAN 2 BETWEEN L&P AND MPS ..... 8**

1  
2  
3  
4  
5  
6  
7  
8  
9  
10  
11  
12  
13  
14  
15

1  
2  
3  
4  
5  
6  
7  
8  
9  
10  
11  
12

**SURREBUTTAL TESTIMONY**

**OF**

**LENA M. MANTLE**

**KCP&L GREATER MISSOURI OPERATIONS COMPANY**

**FILE NO. ER-2010-0356**

13 Q. Please state your name and business address.

14 A. My name is Lena M. Mantle and my business address is Missouri Public  
15 Service Commission, P. O. Box 360, Jefferson City, Missouri 65102.

16 Q. Are you the same Lena M. Mantle who prepared a portion of the Staff Cost of  
17 Service Report (“COS Report”) filed on November 17, 2010, and rebuttal testimony filed on  
18 December 15, 2010, in this case?

19 A. Yes, I am.

20 Q. What is the purpose of your surrebuttal testimony?

21 A. The purpose of my surrebuttal testimony is to: 1) Respond to the rebuttal  
22 testimony of KCP&L – Greater Missouri Operations Company (“GMO”) witness Burton L.  
23 Crawford regarding what he describes as the inclusion of Phantom CTs/Crossroads Energy  
24 Center—Staff’s imputed combustion turbines (“CTs”) issue— in this case; 2) provide  
25 additional information regarding the Special Protection Scheme that GMO has with  
26 Southwest Power Pool regarding Crossroads Energy Center (“Crossroads”) mentioned in the  
27 rebuttal testimony of Dogwood Energy, LLC witness Robert Janssen; and 3) respond to  
28 rebuttal testimony of GMO witnesses Burton L. Crawford, Curtis D. Blanc and Tim M. Rush  
regarding the allocation of the Iatan 2 plant between the rates charged to customers previously

1 served by Missouri Public Service Company (“MPS”) and St. Joseph Power & Light  
2 Company (“L&P”).

3 **PHANTOM TURBINES/CROSSROADS ENERGY CENTER**

4 Q. Doesn’t Mr. Crawford address Staff’s imputation of Combustion Turbines  
5 (which he refers to as “Phantom Turbines”) separately from Crossroads?

6 A. Yes, he does. However, both Staff’s imputation of Combustion Turbines and  
7 the Crossroads issues exist because of resource planning decisions made by GMO (then  
8 Aquila, Inc.) to replace the capacity after its purchased power agreement with Aries (Aries  
9 PPA) ended in May 2005. So they should not be considered two separate issues.

10 Q. Was Mr. Crawford’s description of the process that occurred when GMO was  
11 preparing to replace the Aries PPA correct?

12 A. No it is not. I agree with Mr. Crawford that one of the reasons given by GMO  
13 to only build three combustion turbines and to enter into a purchased power contract for 200  
14 megawatts (MW) was to diversify its supply portfolio. However, Mr. Crawford was not  
15 correct in his rebuttal testimony when he testified that:

16 GMO concluded that it would be prudent to spread the execution and operating  
17 risks from the resource additions between building [combustion turbines] CTs  
18 and adding a PPA that contained some level of base load capacity. This would  
19 reduce the Company’s dependence on any one fuel source. *It would also*  
20 *ensure that the additional capacity would include both base load and peaking*  
21 *capacity.* (page 3, lines 3-7) Emphasis added

22  
23 Q. How is this testimony incorrect?

24 A. In rebutting Staff’s positions regarding two imputed combustion turbines, Mr.  
25 Crawford stated that by building combustion turbines and adding a purchased power  
26 agreement (“PPA”), GMO would *ensure* that it would add both base load and peaking  
27 capacity. He was correct that GMO would ensure that it acquire additional peaking capacity

Surrebuttal Testimony of  
Lena M. Mantle

1 since it was building the two CTs. However, GMO at that point could not ensure that it could  
2 acquire base load capacity through a PPA. GMO may have hoped for or wanted the PPA to  
3 result in base load capacity for GMO, but it could not ensure that the PPA that it issued in  
4 2003 for additional capacity would result in base load capacity, given the Request for  
5 Proposals (“RFP”) that it issued did not limit the responses only to base load capacity. Even  
6 if the RFP had only asked for base load proposals, there is no way that GMO could ensure  
7 that it would acquire some base load capacity as a result of the RFP.

8 Q. Did GMO receive some base load bids in response to its 2003 RFP?

9 A. Yes it did. \*\* \_\_\_\_\_  
10 \_\_\_\_\_  
11 \_\_\_\_\_  
12 \_\_\_\_\_  
13 \_\_\_\_\_  
14 \_\_\_\_\_  
15 \_\_\_\_\_  
16 \_\_\_\_\_  
17 \_\_\_\_\_ \*\*

18 Q. So what was the result of GMO’s final analysis?

19 A. At that time, Staff was told that GMO was finalizing a contract with an  
20 undisclosed bidder. However, when those negotiations failed, GMO ended up with a short-  
21 term PPA with Crossroads, then owned by a GMO affiliate, Aquila Merchant. A more  
22 detailed description can be found in Appendix 5, Schedule LMM-1 of the Staff COS report  
23 filed on November 17, 2010.

Surrebuttal Testimony of  
Lena M. Mantle

1 Q. Did GMO's decision to only build three combustion turbines and issue a RFP  
2 for additional capacity result in diversification as desired by GMO?

3 A. GMO's issuance of a RFP did result in some limited diversification. GMO did  
4 enter into a contract with Nebraska Public Power District (NPPD) for 75 MW of base load  
5 capacity and energy; not as a result of the RFP but as a result of GMO's contact with  
6 neighboring utilities when the PPA with the undisclosed bidder fell through. However, the  
7 majority of the 200 MW of capacity GMO needed was supplied through short-term PPAs  
8 with gas-fired facilities.

9 Q. Has Staff "overlooked" the NPPD contract in this case, as Mr. Crawford  
10 asserts on page 7, lines 4 through 10?

11 A. No, Staff has not. Staff has included this NPPD contract in its fuel runs and  
12 the capacity charges of that contract as expenses in this case. In addition, it was included in  
13 the description of GMO's capacity additions since 2000 found in Appendix 5, Schedule  
14 LMM-1 of the Staff COS report filed on November 17, 2010. It is also included in the Total  
15 Purchases on the GMO capacity balance sheet found on Schedule LMM-2 of the Staff COS  
16 report filed on November 17, 2010.

17 Q. Mr. Crawford discusses GMO's assessment of the risks associated with the  
18 natural gas market on page 5, lines 3 through 11 of his rebuttal testimony. Did the resources  
19 GMO obtained in 2005 lower GMO's risk of high gas prices?

20 A. Only 75 MW of the 500 MW need of GMO was supplied by a non-gas fired  
21 facility. Therefore, the resulting resources did mitigate some of the risk of high gas prices.  
22 However, GMO's inability to acquire long-term contracts other than the contract with NPPD

Surrebuttal Testimony of  
Lena M. Mantle

1 increased its risks of not having capacity available when needed and increased the costs for its  
2 ratepayers in the long run.

3 Q. Mr. Crawford also states on page 10, lines 15 through 16 of his rebuttal  
4 testimony that the Staff imputed a 100 MW capacity contract. Is this correct?

5 A. No, it is not. Staff did not include any capacity contracts in its fuel run or  
6 capacity expenses for GMO, other than the contracts GMO already has.

7 Q. Would ownership of Crossroads lessen GMO's risks?

8 A. GMO would own additional capacity instead of having to rely on short-term  
9 PPAs, but there would still be some risk of being able to get the capacity from Crossroads. It  
10 would not lessen the risks associated with the natural gas markets.

11 Crossroads would have an additional risk - deliverability. Dogwood Energy, LLC  
12 (Dogwood) witness Robert Janssen states on page 9, lines 8 through 11 of his rebuttal  
13 testimony that Crossroads is currently subject to a special protection scheme (SPS).

14 Q. What is a special protection scheme?

15 A. When searching the web for what a special protection scheme is, I obtained  
16 millions of results. There are many publications and scholarly theses written about special  
17 protection schemes and special protection systems that are written by experts in many  
18 countries. An article in the 2009 American Journal of Applied Sciences<sup>1</sup>, describes special  
19 protection schemes as:

20 ...protection strategies designed to detect a particular system condition that is  
21 known to cause unusual stress to the power system and to take some kind of  
22 predetermined action to counteract the observed condition in a controlled  
23 manner.

---

<sup>1</sup> Design of New Load Shedding Special Protection Schemes for a Double Area Power System, American Journal of Applied Sciences 6 (2): 317-327, 2009, ISSN 1546



Surrebuttal Testimony of  
Lena M. Mantle

1 Q. Why does GMO need a special protection scheme for Crossroads?

2 A. According to the response to Data Request No. 0367, attached as schedule  
3 LMM-S1, GMO was granted a special protection scheme because:

4 There are two transmission lines serving Crossroads. If one of the lines were  
5 to trip (line to Moon Lake), the other line could handle 3 of the 4 turbines at  
6 full load. As such, a Special Protection System was installed to ramp one of  
7 the turbines down should the second line coming from Crossroads become  
8 overloaded.

9 Q. Would you explain this data response?

10 A. Yes. There are two transmission lines leaving the Crossroads Energy Facility,  
11 a 230kV line (Moon Lake line) and a 230/115 kV line. If the 230 kV line is not available for  
12 some reason (planned or unplanned) the other line, the 230/115 kV line, is not capable of  
13 handling the full output of all four of the CTs at Crossroads. Therefore, if the 230 kV Moon  
14 Lake line goes down and all four generators are running, the special protection scheme is to  
15 shut down the fourth generator to protect the transmission and distribution system and the  
16 Crossroads facility.

17 Q. Is it likely that the Moon Lake line will be unavailable very often?

18 A. No it is not. Any maintenance on the Moon Lake line is likely to be scheduled  
19 at times that GMO does not need the Crossroads units, i.e., during the spring and fall. So it  
20 will only be unplanned reasons (e.g., extreme weather) that will result in the 230 kV line not  
21 being available when GMO would need the Crossroads units output.

22 Q. Should this be a concern for GMO?

23 A. Currently GMO has the capacity it needs, so in the near-term it will only be a  
24 concern if the fourth Crossroads CT is not available when it is the low cost resource and  
25 GMO has to use a higher cost resource. However, when GMO needs additional capacity in  
26 the future, it could become a concern.

Surrebuttal Testimony of  
Lena M. Mantle

1 Q. How do you respond to Mr. Crawford's assertion on page 7, lines 15 through  
2 16 of his rebuttal testimony that Staff's removal of Crossroads capacity results in a supply  
3 portfolio that does not meet GMO's requirements?

4 A. Mr. Crawford states that Staff's case only included 2,134 MW of capacity for  
5 2010. As shown in schedule LMM-2 in Appendix 5 of Staff's COS report, Staff position on  
6 GMO's total system capacity for 2010 is 2,252 MW.

7 Q. Mr. Crawford describes on pages 8 and 9 of his rebuttal testimony how  
8 Crossroads is a prudent choice for GMO. Why shouldn't it be included as a GMO resource?

9 A. Staff's position, which is stated in its COS Report, is that there are four reasons  
10 that Crossroads should not be included as a GMO resource: (1) affiliate transaction concerns;  
11 2) the delivered price of natural gas to Crossroads has historically been higher than the price  
12 of gas to South Harper; 3) the cost of transmission to move energy from Crossroads to  
13 GMO's service territory; and 4) the ability of GMO to properly provide managerial oversight  
14 to the plant. The special protection scheme is an additional concern.

15 Q. How do you respond to Mr. Crawford's testimony that GMO conducted two  
16 separate analyses that showed that Crossroads would result in the lowest 20-year NPVRR?

17 A. Both analyses were conducted based on 2007 costs when, instead, they should  
18 have been based on 2005 costs. It is Staff's position that GMO was imprudent when it only  
19 built three 105 MW CTs on a site for six CTs in 2004-2005 when its resource plan showed  
20 that five CTs would result in a lower NPVRR – *the very same reason that GMO now states*  
21 *that Crossroads would be a prudent choice.*

22 Q. On page 10, at lines 8 through 11 of his rebuttal testimony, Mr. Crawford  
23 states that Crossroads has met the in-service requirements to be included in the MPS regulated

1 rate base and that Staff engineers witnessed the testing. Has Staff determined that Crossroads  
2 has met the in-service requirements?

3 A. Staff members had been contacted by GMO employees regarding in-service  
4 testing of Crossroads. In September 2008, Staff engineers visited Crossroads, in conjunction  
5 with a visit to The Empire District Electric Plum Point Power plant. The purpose of this visit  
6 was to inspect the facility and obtain information needed for Staff to make a recommendation  
7 to the Commission that the facility be declared fully operational and used for service.  
8 Because it has been Staff's position that Crossroads should not be included as GMO capacity,  
9 Staff has not completed its analysis upon which to make a recommendation as to whether  
10 Crossroads is fully operational and used for service, even though Staff has the information it  
11 requested in September 2008. At this time, Staff would require some updated information  
12 before it could make a recommendation that the Commission find the Crossroads fully  
13 operational and used for service.

14 **ALLOCATION OF IATAN 2 BETWEEN L&P AND MPS**

15 Q. What did Staff consider when deciding how to allocate the Iatan 2 and related  
16 Iatan common plant costs between the rate bases of L&P and MPS?

17 A. Staff took into account three factors—the capacity needs of MPS and L&P, the  
18 ownership rights of MPS and L&P, and impacts on the MPS and L&P rates.

19 Q. Did GMO witnesses provide rebuttal testimony addressing each of these  
20 factors?

21 A. Yes, they did.

22 Q. Would you summarize their rebuttal regarding the capacity needs of MPS and  
23 L&P?

Surrebuttal Testimony of  
Lena M. Mantle

1           A.     Mr. Blanc stated on page 9, lines 5 through 6 of his rebuttal testimony that  
2     GMO did the kind of resource planning that Staff indicated was the best way to determine  
3     how to allocate the costs of Iatan 2. However, such an analysis was not contained in GMO's  
4     workpapers. Staff asked GMO in Staff Data Request No. 0365 to provide the details of the  
5     resource planning to which Mr. Blanc referred. I received a single spreadsheet that contained  
6     the table attached to Mr. Crawford's direct testimony as Schedule BLC-5(HC). It was a 17-  
7     year analysis, but it was only based on the forecasted peaks for MPS and L&P, the current  
8     capacity, and the current load factor of MPS and L&P. The only way that kWh usage was  
9     included in this analysis was in the calculation of the current load factor<sup>2</sup>.

10          Q.     Is this the type of resource planning analysis that Staff was referring to in  
11     Staff's COS report when it stated the best way to determine how to allocate Iatan 2 would be  
12     to base the allocation on resource planning by GMO performed separately for MPS and L&P?

13          A.     No it was not. The appropriate resource planning would take into account  
14     hourly demands and demand-side resources, supply-side resources, integration and risk  
15     analysis as detailed in the Commission's Chapter 22 Electric Resource Planning rules.

16          Q.     Did Mr. Blanc have additional rebuttal testimony regarding the capacity needs  
17     of MPS and L&P?

18          A.     Yes. On page 8, lines 14 through 19 of his rebuttal testimony Mr. Blanc makes  
19     some statements regarding needs of MPS and L&P for base load capacity. Staff agrees with  
20     Mr. Blanc's statement that Staff acknowledges MPS needs for base load capacity. Staff has  
21     been encouraging GMO to acquire additional base load for MPS since it began looking at  
22     replacing the Aries PPA. Mr. Blanc then states that it appears that Staff acknowledges that  
23     L&P does not need base load capacity. Staff has not stated a position on the amount of base

---

<sup>2</sup> Annual load factor is the average annual hourly load divided by the annual peak load.

1 load needs of L&P. Since GMO began doing resource planning for the total company—MPS  
2 and L&P together, there is no way to tell whether L&P needs more or less base load capacity.

3 The Staff's allocation of 100 MW of Iatan 2 to L&P does not change the amount of  
4 base load capacity available to L&P since the 100 MW contract that SJLP had with NPPD  
5 ends May 31, 2011.

6 Q. Did any other GMO witness testify in rebuttal regarding the base load capacity  
7 needs of MPS and L&P?

8 A. Yes. Mr. Crawford states on page 15, line 9 of his rebuttal testimony that  
9 Staff's allocation does not consider base load needs. While Staff's allocation did not  
10 explicitly consider base load needs, Staff's allocation increases the base load capacity of MPS  
11 and while it maintains L&P's current capacity mix of base, intermediate and peaking  
12 resources.

13 Q. Does GMO's allocation consider base needs?

14 A. Despite Mr. Blanc's statement that GMO conducted resource planning on MPS  
15 and L&P in determining its allocation, GMO has not considered the base needs of MPS and  
16 L&P. Its analysis is based on the percentage of total capacity that is base load and an annual  
17 load factor.

18 Mr. Crawford describes on page 15, lines 2 through 7 of his rebuttal testimony how  
19 GMO's proposed allocation results in 60% L&P's projected peak and 61% of MPS's  
20 projected peak being met with base load capacity. This just shows that GMO's allocation  
21 methodology results in MPS and L&P having a very similar percentage of projected peak  
22 being met with base load capacity.

23 Q. Is that not an equitable solution?

Surrebuttal Testimony of  
Lena M. Mantle

1           A.     No. This is not an equitable solution because the loads of L&P and MPS are  
2 very different. L&P load for the test period showed that its heating load is of approximately  
3 the same magnitude of its cooling load which typically signifies a high saturation of electric  
4 heat. Test year loads for MPS showed little response in the winter. L&P has more industrial  
5 usage as a percentage of its total load than MPS. MPS has more weather-sensitive  
6 commercial loads as a percentage of its total load.

7           Q.     Based on their load characteristics would MPS or L&P better use additional  
8 base load capacity?

9           A.     Based on the load characteristics, L&P would more efficiently use additional  
10 base load.

11          Q.     How much of the additional base load capacity of Iatan 2 should be allocated  
12 to L&P?

13          A.     The only way to accurately determine the amount would be through a detailed  
14 resource planning process that takes into account the best way to meet, not just the peak hour  
15 of the year as GMO has done, but every hour's load, to allocate Iatan 2.

16          Q.     Are there other problems with GMO's allocation?

17          A.     Yes. While MPS and L&P combined as GMO have enough capacity, GMO's  
18 allocation leaves L&P without enough capacity to meet its peak load while giving MPS  
19 capacity to spare.

20          Q.     Since they are a combined utility, why does it make a difference if one is short  
21 on capacity as long as the other has excess?

22          A.     It is important because MPS and L&P have different rate structures and costs  
23 are allocated between them. The fuel allocation methodology is based on the capacity

Surrebuttal Testimony of  
Lena M. Mantle

1 assigned to MPS and L&P. If L&P does not have enough capacity to meet its needs, capacity  
2 at the margin for MPS is provided to meet the need. Since L&P will not have enough  
3 capacity to meet its peak load, it will be using the more costly peaking capacity of MPS to  
4 meet its load.

5 Q. GMO witness Tim M. Rush states on page 11 of his rebuttal testimony that  
6 L&P will be looking to acquire another 100 MW of base and peaking capacity. So isn't GMO  
7 planning to meet L&P's capacity deficit?

8 A. In his rebuttal testimony, Mr. Rush specifically stated that L&P would be  
9 looking for additional capacity. When asked in a data request if L&P did planning on its own,  
10 GMO replied that no, it did not.<sup>3</sup> In other responses to Staff Data Requests, GMO also stated  
11 that Kansas City Power & Light Company (KCPL) was doing resource planning for both  
12 GMO and KCPL combined, i.e., as if they are one entity.<sup>4</sup> When asked if a method had been  
13 determined for the allocation of future generation resource additions, GMO responded that no  
14 analysis has been performed to determine how future generation resource additions might be  
15 allocated between KCPL and GMO, and MPS, and L&P.

16 Q. So this may not be the last time the Commission is faced with making a  
17 determination on how to allocate new generating capacity?

18 A. Until KCPL and GMO actually merge and have common rates, and MPS and  
19 L&P have common rates, the Commission is likely to be faced again with the issue of how to  
20 allocate new generating capacity.

21 Q. Did GMO provide rebuttal testimony to Staff's direct testimony on the  
22 ownership rights of MPS and L&P to Iatan 2?

---

<sup>3</sup> Staff data request no. 0361

<sup>4</sup> Staff data request no. 0363

Surrebuttal Testimony of  
Lena M. Mantle

1           A.     Mr. Blanc did on page 9 of his rebuttal testimony. According to Mr. Blanc,  
2     GMO acquired ownership of a portion of Iatan 2 through the collaborative process that led up  
3     to KCPL's regulatory plan.

4           Q.     Do you agree with Mr. Blanc?

5           A.     Mr. Blanc took exception to a statement made in the Staff COS report on page  
6     99. Upon review of the COS report, I realized Staff's statement that if SJLP and Aquila, Inc.  
7     (Aquila) "had not merged, given GMO's poor financial condition when KCPL was looking  
8     for potential partners for Iatan 2, KCPL would not have considered GMO as a potential  
9     partner" was an overstatement. Mr. Blanc was correct that a collaborative process was used  
10    to develop the KCPL experimental regulatory plan, which includes a section of partnership  
11    issues on page 51. This section contains a provision for both Empire and Aquila to be  
12    preferred potential partners in the Iatan 2 plant. However, their preferred status was  
13    contingent upon each of them demonstrating a commercially feasible financing plan. Staff  
14    witness Cary Featherstone discusses in his surrebuttal testimony, conversations he had with  
15    both Aquila and Empire employees regarding the collaborative process used to develop  
16    KCPL's experimental regulatory plan and, in particular, the role Staff had in overcoming  
17    KCPL's early reluctance to consider Empire and Aquila as potential partners.

18          Q.     Did any GMO witness provide rebuttal testimony in response to Staff's third  
19    factor – the impacts on MPS and L&P rates?

20          A.     GMO witness Curtis D. Blanc states on page 8, line 5 through 6 of his rebuttal  
21    testimony that Staff's allocation of 100 MW to L&P and 53 MW to MPS places too large of a  
22    burden on the customers in the L&P service territory. Staff agrees that it places a burden on  
23    L&P customers. However, GMO's allocation of 112 MW to MPS and 41 MW to L&P results



Surrebuttal Testimony of  
Lena M. Mantle

1 in a smaller percentage impact to MPS customers partly because the rates of MPS are  
2 considerably higher than those of L&P. If the L&P rates were higher, the impact on the L&P  
3 customers would be less. Further, over the long run rate impacts to L&P customers should be  
4 lessened by the low-cost power from Iatan 2, similar to how they have benefitted from  
5 owning Iatan 1.

6 The recovery of Iatan 2 costs will place a burden on Kansas City Power & Light  
7 Company (KCPL) and Empire customers also in the near term, just as the addition of Iatan 1  
8 placed a burden on these utilities' customers. However, because of the low cost of generating  
9 electricity at Iatan 2, in the long run it will provide stable low-cost electricity.

10 Q. Does Staff suggest that the impact on customer rates somehow supports its  
11 allocation recommendation as Mr. Blanc states on page 9, lines 21 through 22 of his rebuttal  
12 testimony?

13 A. No, it dos not. It was one of the factors considered; it did not "support" Staff's  
14 allocation.

15 Q. Did GMO bring up another factor that it stated it believes Staff considered?

16 A. Yes. Mr. Blanc further states on page 8, lines 19 through 22 of his rebuttal  
17 testimony that Staff appears to base its recommendation on the assumption that because L&P  
18 could potentially sell excess energy on the market that it may have chosen to add more of the  
19 Iatan 2 base load to L&P.

20 Q. Is his statement accurate?

21 A. No it is not. In its COS report, Staff's discussion of the possibility of L&P  
22 selling excess energy on the market was only part of what Staff considered when it considered

Surrebuttal Testimony of  
Lena M. Mantle

1 ownership rights. Its specific discussion regarding the capacity needs of L&P which appear  
2 on page 99, lines 7 through 12 of the Staff COS report is:

3 Since the NPPD PPA is a base load contract, it would be logical for L&P to  
4 replace it with base load capacity. It would also be logical, since L&P already  
5 has so much base load capacity, that L&P instead add lower capital cost  
6 peaking capacity rather than base load capacity. But, since the opportunity to  
7 own a portion of another base load unit in the Midwest is not likely to occur in  
8 the near future, and given that L&P could sell excess energy on the market,  
9 L&P, as it did when it invested in Iatan 1, may have chosen to add more base  
10 load.

11  
12 However, prior to this discussion of the capacity needs of L&P, on page 99, lines 1  
13 through 5 of the Staff report, appears the following discussion on the needs of MPS:

14 [I]f MPS were a standalone utility, it would be very beneficial for MPS to  
15 diversify its generation portfolio with base load capacity. In addition, MPS  
16 likely will need more capacity, if not in 2010, soon after. The lower fuel cost  
17 of base load capacity would also likely stabilize MPS's fuel costs. Scenario 5  
18 above, all of Iatan 2 allocated to MPS, would be the most appropriate scenario,  
19 if the only consideration is MPS's needs as a standalone utility.

20 Q. So do you agree with Mr. Blanc's statement at the bottom of page 8 of his  
21 rebuttal testimony that such speculation is not a sound basis to determine how to allocate the  
22 costs of Iatan 2 between MPS and L&P?

23 A. While this factor and the other factors Staff considered are not the basis that  
24 Staff would prefer to rely on to allocate the Iatan 2 and related Iatan common costs between  
25 MPS and L&P, because GMO did not do separate resource planning for MPS and L&P, it is  
26 the best that Staff can do.

27 Q. Does this conclude your surrebuttal testimony?

28 A. Yes, it does.

Company Name: GMO Electric  
Case Description: 2010 GMO Elec Rate Case  
Case: ER-2010-0356

Response to Mantle Lena Interrogatories – Set MPSC\_20101222  
Date of Response: 12/29/2010

Question No. :0367

Has GMO been granted a special protection scheme or special protection system by the Southwest Power Pool regarding the delivery of power from Crossroads Energy Center to GMO? If so, please describe the scheme in detail including dates when the scheme was proposed and adopted by the SPP.

RESPONSE:

There are two transmission lines serving Crossroads. If one of the lines were to trip (line to Moon Lake), the other line could handle 3 of the 4 turbines at full load. As such, a Special Protection System was installed to ramp one of the turbines down should the second line coming from Crossroads become overloaded.

GMO was granted approval of the Special Protective Scheme (“SPS”) by SPP. Approval of the SPS by the SPP reliability coordinator required the following:

- Approval of SPP’s System Protection & Control Working Group (“SPCWG”).
- Review by SPP’s Operating Reliability Working Group (“ORWG”) and their Transmission Working Group (“TWG”).
- Final approval was sought and received from SPP’s Market and Operations Policy Committee (“MOPC”) on July 15, 2010.

The SPS was installed and fully operational to approved specifications effective December 14, 2009. Please see the attached SPS operating guide “DR0367\_Crossroads SPS Operating Guide for 230-115kV XFMR(10-22-2009).doc” for a description and detailed explanation of the SPS.

Attachments:

DR0367\_Crossroads SPS Operating Guide for 230-115kV XFMR\_10-22-2009.doc  
Q0367 GMO Verification.pdf

OPERATING GUIDE	Special Protection System (SPS)	CLARKSDALE	Start Date <u>08/31/2009</u>	REV. 0
		230/115 250MVA AUTO TRANSFORMER	End Date <u>Date</u>	Rev Date <u>Date</u>
		OPERATING GUIDE	AUTHOR: <u>SAM PEARCE</u>	PAGE 1 OF 6

### I. Purpose

The Crossroads facility in Clarksdale, MS has four 80MVA generators for a total generation capacity of 320MVA. There are two outlets leaving the facility, a 230kV line to Moon Lake and a 230/115kV autotransformer. The autotransformer has a power rating of 250MVA while the line to Moon Lake is capable of carrying the full generation capacity of 320MVA. Under an N-1 contingency study, the autotransformer is listed as the limiting element and therefore must be protected by Special Protection System (SPS) during this contingency in order for the Crossroads facility to have a firm generation capacity in excess of 250MVA or 238MW. More specifically, a contract with Entergy exists for 300MW of firm generation and an operational SPS is a condition for the contract.

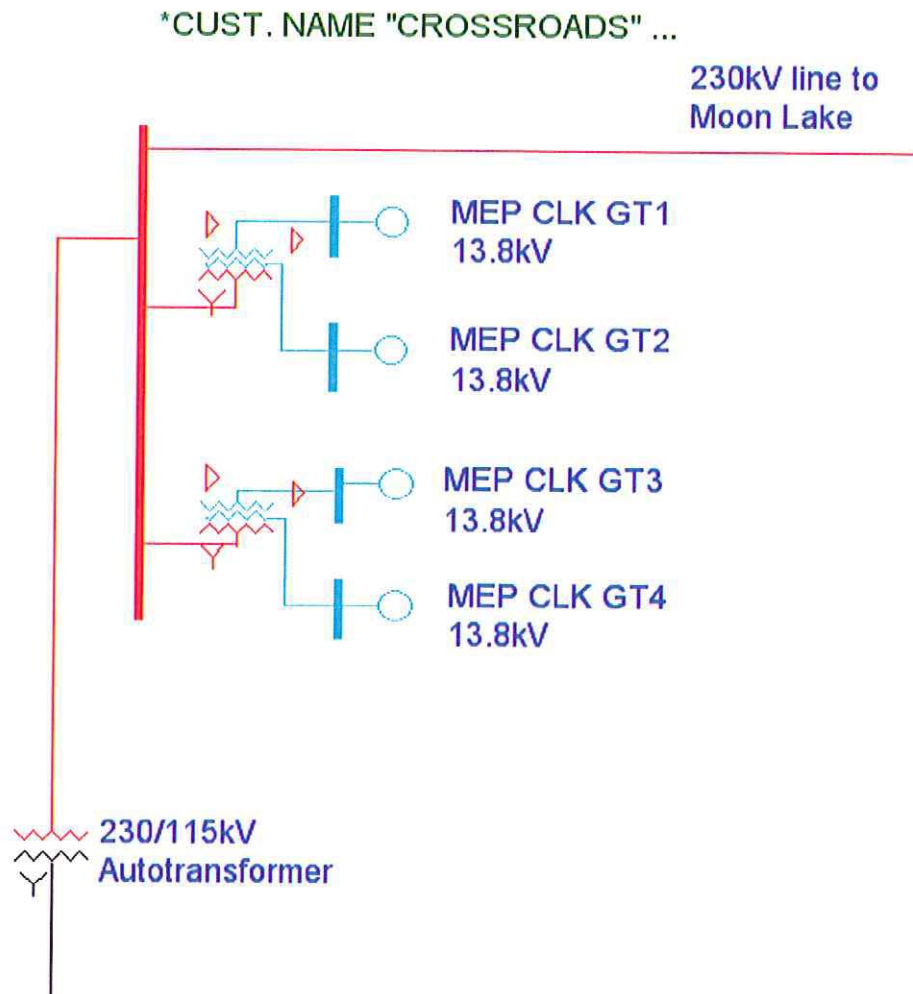

OPERATING GUIDE	Special Protection System (SPS)	CLARKSDALE 230/115 250MVA AUTOTRANSFORMER	Start Date <u>08/31/2009</u> End Date <u>Date</u>	REV. 0 Rev Date <u>Date</u>
		OPERATING GUIDE	AUTHOR: <u>SAM PEARCE</u>	PAGE 2 OF 6

## II. Applicability

In the event that the 230kV intertie is lost, the 230-115kV autotransformer can become overloaded. The capacity of the four connected generators would exceed the power rating of the autotransformer. One of the generators should be shut down in order to keep the autotransformer and three remaining generators online. Three of the 80MVA generators would have a total capacity of 240MVA and therefore would not overload the autotransformer. The SPS is hardwired such that Unit 1 generator is always the generator that is shut down.

## III. Problem Definition

The critical contingency scenario is when all four generators are online and the 230kV line to Moon Lake is lost. The autotransformer will become overloaded and without quick action will also go offline resulting in the entire facility being taken offline.

The first step towards corrective action is to detect an overload condition on the autotransformer. An orderly shutdown of one of the generators is initiated which will ramp down the output power of the generator at a rate of approximately 10MVA per minute. If the transformer continues to be overloaded after ten minutes, then the generator breaker is tripped.

## IV. Operating Guide Execution

### General

The SPS will not be initiated until ten seconds after an overload condition is detected, which is much slower than any fault protection on the system. A ten minute worst case shutdown time is allowed for, which is significantly faster than the time it would take for the transformer to be damaged by an overload condition. If the generator fails to shut down after ten minutes while still overloaded, then the generator lockout will be tripped. The ten minute delay provides adequate time for the generator to shutdown normally while still safely below the time necessary to damage the autotransformer. An additional timer was added to trip the generator lockout if the transformer is more than %16 overloaded after four minutes. This was added to ensure the SPS operates faster if the transformer is more severely overloaded and could also cover cases where the orderly shutdown fails to initiate.

The SPS operates utilizing redundant SEL-387 relays powered with separately fused DC supplies that trip the breaker using separate trip coils. As required for SPS approval by SERC and SPP, the autotransformer is protected with an entirely redundant automated protection scheme.

### SPS Normal Operation

If the SPS operates, the operator should verify that the autotransformer was overloaded and begin retrieving event history including event reports and entire SER. The generator can be safely restarted according to the manufacturer's guidelines without delay as long as the total power through the autotransformer remains below 250MVA.



OPERATING GUIDE	Special Protection System (SPS)	CLARKSDALE 230/115 250MVA AUTOTRANSFORMER	Start Date <u>08/31/2009</u> End Date <u>Date</u>	REV. 0 Rev Date <u>Date</u>
		OPERATING GUIDE	AUTHOR: <u>SAM PEARCE</u>	PAGE 3 OF 6

### SPS Fails to Operate / Alarms

The SEL-387 relays utilize the "Demand Ammeter" function to trigger an alarm. The SPS should operate faster than the alarm, therefore if an alarm is detected prior to the SPS operating, an operator will have to take action. This alarm existed prior to installation of the SPS and the procedure for managing the alarm is unchanged.

**Procedure:** SOP 101: Overload Protection of the Auto-transformer

If all four units are on-line at full load ( above 250 MW ) And the 230 KV line to Moon Lake lost one unit ( unit # 1 ) MUST be given a normal shut down command from the HMI and be off-line within ten minutes from the time The 230 KV line is lost. If after ten minutes the auto-Transformer is still over loaded ( 250 MW ) then that unit MUST be tripped off-line to drop the load below the limits Of the auto-transformer.

Must notify Entergy and KCPL about the event.

If the alarm is received legitimately prior to the SPS operating, Entergy SOC should be informed of the failure to operate and troubleshooting should begin to diagnose why the SPS failed to operate.

### SPS Inadvertent Operation

The SPS operates based on overload on the autotransformer. The only time the SPS should be overloaded is when all four generators are online and the intertie to Moon Lake is lost. Another possible cause of overload is if power is flowing from Moon Lake through the autotransformer, but modeling shows this to be highly unlikely.

If the SPS operates, then the operator should verify the following:

- Was the autotransformer overloaded when SPS operated
- Is the intertie to Moon Lake in service

If the autotransformer was not overloaded then it can be assumed that the SPS operated falsely. If the intertie to Moon Lake is in service then the total generation can be brought up to 300MW, if the intertie is out of service then the total generation can be brought up to 238MW.

If the operation was indeed inadvertent then the operator can override the shutdown or restart the generator according to the manufacturer's guidelines. Beginning with retrieving the event history including event reports and the entire SER, troubleshooting should begin to identify the problem.

### Monitoring

Two status bits for Entergy to monitor can be read by Entergy's RTU at Modbus addresses 10207 and 10208. The first status bit is ON for normal operation of the relays and will turn OFF if either relay fails or loses communication. The second status bit will assert if the SPS attempts to trip the generator.

### SPS Maintenance

The SPS enables Crossroads to meet the requirements set forth by Entergy to grant a firm 300MW transmission service reservation. Although maintenance outages will be scheduled with Entergy, they will typically be at times when Crossroads is generating less than 250MVA when the SPS will not be called on to protect the autotransformer.

OPERATING GUIDE	Special Protection System (SPS)	CLARKSDALE  230/115 250MVA AUTOTRANSFORMER	Start Date <u>08/31/2009</u>  End Date <u>Date</u>	REV. 0  Rev Date <u>Date</u>
		OPERATING GUIDE	AUTHOR: <u>SAM PEARCE</u>	PAGE 4 OF 6

### Reporting

Entergy SOC and the ICT Reliability Coordinator should be informed prior to the SPS being taken out of service and immediately following any unintentional SPS loss of service. Entergy and the ICT Reliability Coordinator should also be informed if the SPS fails to operate or operated inadvertently, the source of the problem, and what steps were taken to correct the problem.

Entergy SOC contact information:

870-541-3974 (Real-time desk)

ICT Reliability Coordinator contact information:

501-614-3511 (Real-time desk)

## V. Appendix

For Schematics and one-line diagram see attachment:  
SPS - Crossroads 230-115kV Autotransformer Design Package.pdf

The relay settings are included with changes in bold and descriptions in parenthesis. The changes show what settings were changed to implement the SPS.

## Relay Settings

CROSSROADS AUTO-XTR T6  
FID=SEL-387-5-R307-V0-Z002002-D20010518  
SETTINGS CHANGED SINCE EVENT  
Group 1 Settings

RID =87P/T6  
TID =CROSSROADS AUTO-XTR T6  
E87W1 = Y1  
E87W2 = Y1  
E87W3 = N  
E87W4 = N  
EOC1 = N **Change to: Y** (enable winding 1 overcurrent elements)  
EOC2 = Y  
EOC3 = N  
EOC4 = N  
EOCC = N  
ESLS1 = N **Change to: Y** (enable SELLogic set 1)  
ESLS2 = N  
ESLS3 = N  
W1CT = Y  
W2CT = Y  
W3CT = Y  
W4CT = Y  
CTR1 = 160  
CTR2 = 320  
CTR3 = 400  
CTR4 = 40

OPERATING GUIDE	Special Protection System (SPS)	CLARKSDALE	Start Date <u>08/31/2009</u>	REV. <b>0</b>
		230/115 250MVA AUTO TRANSFORMER	End Date <u>Date</u>	Rev Date <u>Date</u>
		OPERATING GUIDE	AUTHOR: <u>SAM PEARCE</u>	PAGE 5 OF 6

MVA = 250.0  
ICOM = Y  
W1CTC = 12  
W2CTC = 12  
VWDG1 = 230.00  
VWDG2 = 115.00  
TAP1 = 3.92  
TAP2 = 3.92  
O87P = 0.30  
SLP1 = 30  
SLP2 = 60  
IRS1 = 3.0  
U87P = 8.0  
PCT2 = 15  
PCT4 = 15  
PCT5 = OFF  
TH5P = 1.00  
TH5D = 60.000  
DCRB = Y  
HRSTR = Y

E32I = 1  
32IOP = 12  
a0 = 0.10  
50GP = 2.00  
50P11P = **Newly enabled, set to: 4** (CT secondary current for 250MVA)  
50P11D = **Newly enabled, set to: 600** (10 second delay before initiating generator shutdown)  
50P11TC = **Newly enabled, set to: 1** (Set to default, additional logic not necessary)  
50P12P = **Newly enabled, set to: 4.55** (CT secondary current for 290MVA)  
50P12TC = **Newly enabled, set to: 1** (Set to default, additional logic not necessary)  
50P21P = OFF  
50P22P = OFF  
50P23P = OFF  
50P24P = OFF  
51P2P = OFF  
50Q21P = OFF  
50Q22P = OFF  
51Q2P = OFF  
50N21P = OFF  
50N22P = OFF  
51N2P = OFF  
DATC2 = 15  
PDEM2P = 4.00  
QDEM2P = 1.00  
NDEM2P = 1.00  
TDURD = 10.000  
CFD = OFF  
S1V1 = **Newly enabled, set to: 50P11** (Set to detect overload)  
S1V1PU = **Newly enabled, set to: 36000** (10 minutes before element is picked up)  
S1V1DO = **Newly enabled, set to: 10** (Short dropout time to ensure lockout)  
S1V2 = **Newly enabled, set to: 50P12** (Set to detect overload exceeding 16%)  
S1V2PU = **Newly enabled, set to: 14400** (4 minutes before element is picked up)  
S1V2DO = **Newly enabled, set to: 10** (Short dropout time to ensure lockout)  
TR1 = 87R + 87U + 32IF



OPERATING GUIDE	Special Protection System (SPS)	CLARKSDALE 230/115 250MVA AUTOTRANSFORMER	Start Date <u>08/31/2009</u> End Date <u>Date</u>	REV. 0 Rev Date <u>Date</u>
		OPERATING GUIDE	AUTHOR: <u>SAM PEARCE</u>	PAGE 6 OF 6

TR2 =PDEM2  
 TR3 =50P31 + 51P3T + OC3 Change to: 0  
 TR4 =87R + 87U Change to: 0  
 TR5 =0  
 ULTR1 =!87R \* !87U \* !32IF  
 ULTR2 =!50P23  
 ULTR3 =!50P33 Change to: 0  
 ULTR4 =!(50P13 + 50P23 + 50P33) Change to: 0  
 ULTR5 =0  
 52A1 =IN102  
 52A2 =IN101  
 52A3 =IN103  
 52A4 =0  
 CL1 =CC1 + LB4 + /IN104  
 CL2 =CC2 + /IN105  
 CL3 =CC3 + /IN106  
 CL4 =0  
 ULCL1 =TRIP1 + TRIP4  
 ULCL2 =TRIP2 + TRIP4  
 ULCL3 =TRIP3 + TRIP4 Change to: 0  
 ULCL4 =0  
 ER =/87R + /87U + /32IF  
 OUT101 =TRIP2  
 OUT102 =TRIP2(Not Used) Change to: 0  
 OUT103 =TRIP3(Not Used) Change to: 0  
 OUT104 =TRIP1  
 OUT105 =CLS1(Not Used) Change to: 50P11T (Initiate Shut Down of Unit 1)  
 OUT106 =CLS2(Not Used) Change to: (S1V1T + S1V2T) (Trip Unit 1 Lockout)  
 OUT107 =87R (Not Used) Change to: 0