

**BEFORE THE PUBLIC SERVICE COMMISSION
OF THE STATE OF MISSOURI**

Application of BPS Telephone Company)
for Approval of an Agreement for Interconnection)
Under the Telecommunications Act of 1996)

Case No. TK-2008-_____

APPLICATION OF BPS TELEPHONE COMPANY

BPS Telephone Company (“BPS” or “Company”), by and through its undersigned counsel and pursuant to 4 CSR 240-3.513(1) and the Rules of Practice and Procedure of the Missouri Public Service Commission (“Commission”), hereby files this application for approval, under the Telecommunications Act of 1996 (the “Act”), of an agreement for interconnection and between BPS and Big River Telephone Company, LLC (“Big River”) that the parties voluntarily entered into on or about January 11, 2008. In support of this application, Company states as follows:

1. BPS is a Missouri corporation whose principal place of business is located at 120 Stewart Street, Bernie, Missouri 63822. Under authority granted by the Commission, the Company provides local exchange telecommunications service to customers located in and around the Missouri cities of Bernie, Parma, and Steele. A copy of BPS’s Certificate of Good Standing, issued by the Secretary of State of Missouri, is attached to this application as Appendix A and is incorporated herein by reference.

2. BPS is a “telecommunications company” and also a “public utility,” as those terms are defined in Section 386.020, RSMo. 2000; therefore, the Company is subject to the jurisdiction and regulatory supervision of the Commission, as provided by law.

3. There are no final, unsatisfied judgments or decisions pending against BPS from any federal or state regulatory agency or court that involve customer service or rates and that have occurred within the three (3) years immediately preceding the filing of this application. The Company also has no annual report or assessment fees that are overdue. BPS currently is a party to one other matter pending before the Commission: Case No. IO-2008-0187.

4. Big River is a Delaware limited liability company, duly qualified to conduct business in Missouri, whose principal place of business is located at 24 South Minnesota Avenue, Cape Girardeau, MO 63703. Big River is a "competitive telecommunications company," as that term is defined in Section 386.020, RSMo 2000, and, under authority granted by the Commission, provides competitive local exchange and interexchange telecommunications services to customers in various locations in Missouri.

5. Pleadings, notices, orders, and other correspondence and communications concerning this application should be addressed to the undersigned counsel and also to:

Lisa Winberry
BPS Telephone Company
120 Stewart Street
P.O. Box 550
Bernie, MO 63822
Phone: (573) 293-2277
winberry@bpstelephone.com

John Jennings
Big River Telephone Company
24 South Minnesota Avenue
Cape Girardeau, MO 63703
Phone: (573) 651-3373
jjennings@bigrivertelephone.com

6. Pursuant to and in accordance with the Act, and after good faith negotiations, BPS and Big River reached agreement on and executed an interconnection agreement. Those negotiations resolved all issues between the parties; therefore, there will be no issues that need to be resolved through mediation or arbitration if the Commission approves the agreement without change. A copy of the interconnection agreement that BPS and Big River have voluntarily entered into is attached to this application as Appendix B and is incorporated herein by reference.

7. BPS requests that, consistent with the requirements of the Act and of Missouri law, the Commission expeditiously approve the interconnection agreement and that it do so without change, suspension, or delay in implementing the terms of that agreement. As reflected in the affidavit of Lisa Winberry, which is attached to this application as Appendix C and is incorporated herein by reference, the Company represents that the agreement complies fully with both Missouri law and Section 252(e) of the Act because the terms of the agreement are consistent with the public

interest, convenience, and necessity and do not discriminate against any telecommunications carrier.

8. The Act vests the Commission with authority to grant the relief that BPS is requesting in this application. Specifically, Section 252(a) of the Act provides, in relevant part, as follows:

(a) AGREEMENTS ARRIVED AT THROUGH NEGOTIATION

- (1) **VOLUNTARY NEGOTIATIONS** – Upon receiving a request for interconnection, services, or network elements pursuant to section 251, an incumbent local exchange carrier may negotiate and enter into a binding agreement with the requesting telecommunications carrier or carriers without regard to the standards set forth in subsections (b) and (c) of section 251. The agreement shall include a detailed schedule of itemized charges for interconnection and each service or network element included in the agreement. *The agreement, including any interconnection agreement negotiated before the date of enactment of the Telecommunications Act of 1996, shall be submitted to the State commission under subsection (e) of this section.* (emphasis added)

Moreover, the Act provides that the Commission may reject an agreement reached through voluntary negotiations only if that agreement is discriminatory to a non-party or is inconsistent with the public interest, convenience, and necessity. Section 252(e)(2) of the Act states, in relevant part, as follows:

GROUND FOR REJECTION. – The State Commission may only reject –

- (A) an agreement (or any portion thereof) adopted by negotiation under subsection (a) if it finds that --
 - (i) the agreement (or portion thereof) discriminates against a telecommunications carrier not a party to the agreement; or
 - (ii) the implementation of such agreement or portion is not consistent with the public interest, convenience, and necessity;

The interconnection agreement that BPS and Big River have entered into does not satisfy either of these statutory criteria for rejection.

WHEREFORE, for the reasons stated in its application, BPS respectfully requests the Commission to issue an order that: (1) expeditiously approves the interconnection agreement that

was voluntarily negotiated between the Company and Big River, and (2) grants such other relief as the Commission may deem reasonable under the circumstances.

Respectfully submitted,



W. R. England, III MBN 23975
L. Russell Mitten MBN 27881
BRYDON, SWEARENGEN & ENGLAND P.C.
312 E. Capitol Avenue
P. O. Box 456
Jefferson City, MO 65102
Phone: (573) 635-7166
Fax: (573) 635-3847
Email: rmitten@brydonlaw.com

ATTORNEYS FOR BPS TELEPHONE
COMPANY

VERIFICATION

STATE OF MISSOURI)
) SS
COUNTY OF STODDARD)

Lisa Winberry, being duly sworn on oath, deposes and says that she is Manager of BPS Telephone Company, that she has read the foregoing application and knows the contents thereof, and that the information contained in that application is true and correct to the best of her knowledge and belief.

BPS TELEPHONE COMPANY

BY: *Lisa Winberry*
Lisa Winberry

Subscribed and sworn to before me, the undersigned Notary Public in and for the county and state aforesaid, on the 22nd day of January, 2008.

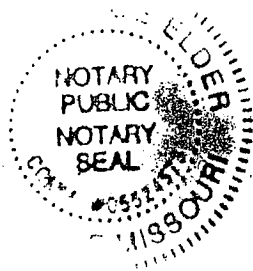

Belinda Poe Elder
Notary Public

My Commission expires:

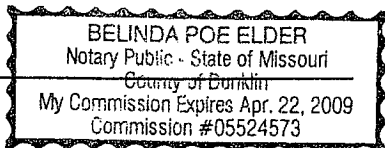

CERTIFICATE OF SERVICE

I hereby certify that a true and correct copy of the above and foregoing document was delivered by electronic mail, on the 22nd day of January 2008, to the following:

General Counsel
Missouri Public Service Commission
200 Madison Street, Suite 800
P.O. Box 360
Jefferson City, MO 65102-0360

Office of the Public Counsel
Governor Office Building
200 Madison Street, Suite 650
P.O. Box 2230
Jefferson City, MO 65102-2230

/s/ L. Russell Mitten

STATE OF MISSOURI



Robin Carnahan
Secretary of State

CORPORATION DIVISION
CERTIFICATE OF GOOD STANDING

I, ROBIN CARNAHAN, Secretary of the State of Missouri, do hereby certify that the records in my office and in my care and custody reveal that

B P S TELEPHONE CO.
00398031

was created under the laws of this State on the 29th day of June, 1994, and is in good standing, having fully complied with all requirements of this office.

IN TESTIMONY WHEREOF, I have set my hand and imprinted the GREAT SEAL of the State of Missouri, on this, the 18th day of January, 2008

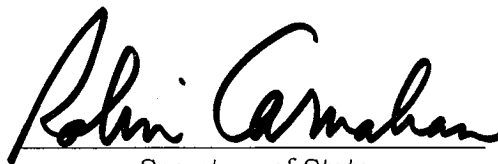
Secretary of State



Certification Number: 10371406-1 Reference: jw

Verify this certificate online at <http://www.sos.mo.gov/businessentity/verification>

AGREEMENT

by and between

BPS TELEPHONE COMPANY

and

BIG RIVER TELEPHONE COMPANY, LLC

	PREFACE.....	3
1.	Scope of this Agreement	4
2.	Intentionally omitted.....	4
3.	Regulatory Approvals.....	4
4.	Term and Termination	4
5.	Attachments and Appendices	5
6.	Applicable Law.....	5
7.	Assignment.....	6
8.	Assurance of Performance	6
9.	Audits.....	7
10.	Authorization.....	8
11.	Billing and Payment; Disputed Amounts.....	8
12.	Confidentiality	10
13.	Counterparts	12
14.	Default	12
15.	Discontinuance of Service	13
16.	Dispute Resolution.....	13
17.	Force Majeure.....	13
18.	Forecasts	14
19.	Fraud	14
20.	Good Faith Performance	14
21.	Headings.....	14
22.	Indemnification.....	14
23.	Intentionally Omitted.....	16
24.	Intellectual Property	16
25.	Joint Work Product	17
26.	Law Enforcement.....	17
27.	Liability.....	17
28.	Network Management.....	19
29.	Notice of Network Changes	20
30.	Notices	20
31.	Performance Standards.....	22
32.	Point of Contact for Customers.....	22
33.	Publicity and Use of Trademarks or Service Marks	22
34.	References	23
35.	Relationship of the Parties.....	23
37.	Subcontractors.....	24
38.	Successors and Assigns.....	24
39.	Survival	24
40.	Taxes	24
41.	Technology Upgrades.....	25
42.	Territory	25
43.	Third Party Beneficiaries.....	25
44.	Filing of Agreement.....	25
45.	252(i) Obligations.....	25
46.	Use of Service	25

47. No Waiver25
48. Warranties26
49. Entire Agreement.....26
SIGNATURE PAGE.....27

PREFACE

This Agreement ("Agreement") shall be deemed effective upon approval by the Commission (the "Effective Date"), between BPS Telephone Company ("BPS"), a corporation organized under the laws of the State of Missouri, with offices at 120 Stewart Street, P.O. Box 550, Bernie MO 63822, and Big River Telephone Company, LLC ("Big River"), a limited liability company organized under the laws of the State of Delaware with offices at 24 S. Minnesota Ave., Cape Girardeau, MO 63703. (Big River and BPS may be referred to hereinafter, each, individually as a "Party," and, collectively, as the "Parties").

WHEREAS, the Parties wish to establish interconnection arrangements for the purpose of transmission and termination of Telecommunications traffic that is within the scope of this Agreement, and

WHEREAS, the interconnection between the Parties will allow the Customers of each Party to complete local calls to the Customers of the other Party within the local calling areas of BPS ("Local Interconnection"); and

WHEREAS, this is intended to fulfill the Parties' needs to exchange Local Traffic.

Now, therefore, in consideration of the terms and conditions contained herein, BPS and Big River hereby mutually agree as follows:

GENERAL TERMS AND CONDITIONS

In consideration of the mutual promises contained in this Agreement, and intending to be legally bound, Big River and BPS hereby agree as follows:

1. Scope of this Agreement

- 1.1 This Agreement includes the Principal Document, ("General Terms and Conditions"), including Attachments A ("Glossary of Terms"); B ("Additional Services"); C ("Interconnection and Number Portability"); and D ("Pricing"), Appendix A ("Designation of Interconnection Point(s), Compensation, Charges, Directory Listing Services"), and Appendix B (Network/Interconnection Diagrams). This Agreement specifies the rights and obligations of each Party with respect to the establishment of Local Interconnection within the incumbent service area of BPS. Certain terms used in this Agreement shall have the meanings defined in the Glossary of Terms, or as otherwise elsewhere defined throughout this Agreement. Certain other terms used but not defined herein will have the meanings ascribed to them in the Act and in the FCC's and the Commission's Rules and Regulations.
- 1.2 If any provision of this Agreement and an applicable Tariff cannot be reasonably construed or interpreted to avoid conflict, the provision contained in this Agreement shall prevail. If any provision contained in the General Terms and Conditions of the Agreement and any attachment or appendix hereto cannot be reasonably construed or interpreted to avoid conflict, the provision contained in the attachment or appendix shall prevail.
- 1.3 Except as otherwise provisioned in the Agreement, the Agreement may not be waived or modified except by a written document that is signed by the Parties. Subject to the requirements of Applicable Law, a Party shall have the right to add, modify, or withdraw, its Tariff(s) at any time, without the consent of, or notice to, the other Party.
- 1.4 In connection with this Agreement, a Party may purchase services from the other Party pursuant to that other Party's Tariff. In such instances, the rates, terms, and conditions of the other Party's Tariff shall apply.

2. Intentionally omitted.

3. Regulatory Approvals

- 3.1 This Agreement, and any amendment or modification hereof, will be submitted to the Commission for approval within thirty (30) Days after obtaining the last required Agreement signature. Big River and BPS shall use their best efforts to obtain approval of this Agreement by any regulatory body having jurisdiction over this Agreement. In the event any governmental authority or agency rejects any provision hereof, the Parties shall negotiate promptly and in good faith such revisions as may reasonably be required to achieve approval.

4. Term and Termination

- 4.1 This Agreement shall be effective as of the Effective Date and, unless cancelled or

terminated earlier in accordance with the terms hereof, and shall continue in effect for a period of 2 years (24 months) after the Effective Date of this Agreement (the "Initial Term"). Thereafter, this Agreement shall renew automatically for successive six (6) month terms, commencing on the termination date of the initial term or latest renewal term and continue in force and effect unless and until cancelled or terminated as provided in this Agreement.

- 4.2 Either BPS or Big River may terminate this Agreement effective upon the expiration of the Initial Term or each subsequent renewal term by providing written notice of termination at least ninety (90) days in advance of the date of termination.
- 4.3 In the event of such termination, if either BPS or Big River has requested negotiations of a new interconnection agreement, those service arrangements made available under this Agreement and existing at the time of termination shall continue without interruption until a replacement agreement has been executed by the Parties either (a) under a new agreement voluntarily executed by the Parties; (b) under a new agreement negotiated pursuant to the provisions of the Act; or c) under any agreement that may be available according to the provisions of Section 252(i) of the Act, but in no case will the existing service arrangements continue for longer than 270 days after the termination date.
- 4.4 If either BPS or Big River provides notice of termination pursuant to Section 4 and by 11:59 PM Central Time on the proposed date of termination neither BPS nor Big River has requested negotiation of a new interconnection agreement, (a) this Agreement will terminate, and (b) the Services being provided under this Agreement at the time of termination will continue until the earlier of (1) the date such services are cancelled by Big River or (2) 180 days from the date of termination.

5. Attachments and Appendices

The following Attachments are a part of this Agreement:

- Attachment A -- GLOSSARY OF TERMS
- Attachment B -- ADDITIONAL SERVICES
- Attachment C -- INTERCONNECTION AND NUMBER PORTABILITY
- Attachment D -- PRICING
- Appendix A -- DESIGNATION OF INTERCONNECTION POINT(S),
COMPENSATION, CHARGES, DIRECTORY LISTING
SERVICES
- Appendix B -- NETWORK/INTERCONNECTION DIAGRAMS

6. Applicable Law

- 6.1 The construction, interpretation and performance of this Agreement shall be governed by (a) the laws of the United States of America, including but not limited to the Act, and (b) the laws of the State of Missouri, (c) the rules, regulations and orders of the FCC and the Commission, and (d) any orders, rulings, and decisions of courts of competent jurisdiction. All disputes relating to this Agreement shall be resolved through the application of such laws.

- 6.2 Each Party shall remain in compliance with Applicable Law in the course of performing this Agreement.
- 6.3 Neither Party shall be liable for any delay or failure in performance caused or required by Applicable Law, or the acts or failures to act of any governmental entity or official to the extent such acts nor failures to act were not caused or solicited by either Party and/or comply with Applicable Law.
- 6.4 If any provision of this Agreement shall be invalid or unenforceable under Applicable Law, such invalidity or unenforceability shall not invalidate or render unenforceable any other provision of this Agreement; provided, that if the invalid or unenforceable provision is a material provision of this Agreement, or the invalidity or unenforceability materially affects the rights or obligations of a Party hereunder or the ability of a Party to perform any material provision of this Agreement, the Parties shall promptly renegotiate in good faith and amend in writing this Agreement in order to make such mutually acceptable revisions to this Agreement as may be required in order to conform the Agreement to Applicable Law.
- 6.5 If any final and unstayed legislative, regulatory, judicial or other governmental decision, order, determination or action, or any change in Applicable Law, materially affects any material provision of this Agreement, the rights or obligations of a Party hereunder, or the ability of a Party to perform any material provision of this Agreement, the Parties shall promptly renegotiate in good faith and amend in writing this Agreement in order to make such mutually acceptable revisions to this Agreement as may be required in order to conform the Agreement to Applicable Law.

7. Assignment

- 7.1 Any assignment by either Party of any right, obligation, or duty, in whole or in part, under this Agreement or of any interest in this Agreement, without the written consent of the other Party, which consent shall not unreasonably be withheld, shall be void, and the assigning Party shall remain responsible for all obligations hereunder; provided, however, that no such written consent shall be required in order for either Party to assign any right, obligation, duty, or interest under this Agreement to that Party's Affiliate.

8. Assurance of Performance

- 8.1 When reasonable grounds for insecurity arise with respect to the performance of either Party, the other Party may in writing demand adequate assurance of due performance.
- 8.2 The reasonableness of grounds for insecurity and the adequacy of any assurance offered shall be determined according to Telecommunications industry standards. Reasonable grounds for insecurity include, but are not limited to: (a) prior to the execution of this Agreement, a Party has sought a voluntary receivership or bankruptcy (or had a receivership or bankruptcy proceeding initiated against it); (b) the failure of a Party to demonstrate that it is creditworthy after the execution of this Agreement, (c) the failure of a Party to timely pay a bill or perform a service or obligation as required by this Agreement (except such portion of a bill that is

subject to a good faith, bona fide dispute and as to which Party has complied with all requirements set forth in Section 11), or (d) a Party admits its inability to pay debts as such debts become due.

- 8.3 Unless otherwise agreed by the Parties, after receipt of a justified demand, a Party shall have thirty (30) days to provide a security deposit.
- 8.4 To the extent that a cash deposit may be required, the Parties intend that the provision of such deposit shall constitute the grant of a security interest in the deposit pursuant to Article 9 of the Uniform Commercial Code as in effect in any relevant jurisdiction.
- 8.5 A Party shall accrue interest on a cash deposit required under this Section at an annual rate equal to 6%.
- 8.6 To the extent that a cash deposit is required under this Section, a Party may (but is not obligated to) draw on the cash deposit upon thirty (30) days written notice to the Purchasing Party in respect of any amounts to be paid hereunder that are not paid within thirty (30) days of the date that payment of such amounts is required by this Agreement (including provisions regarding bona fide disputes).
- 8.7 If a Party draws on the cash deposit, the other Party shall provide a replacement or supplemental cash deposit in accordance with the requirements of this Section.
- 8.8 Notwithstanding anything else set forth in this Agreement, if a Party makes a request for assurance of performance in accordance with the terms of this Section, and the other Party fails to provide adequate assurance of due performance in accordance with the terms of this Section, the failure of which will substantially impair the value of the Agreement to the Party requesting the assurance, then the aggrieved Party may suspend its own performance under the Agreement until such time as the other Party provides such assurance of performance.
- 8.9 The fact that assurance of performance is requested by a Party hereunder shall in no way relieve the other Party from compliance with the requirements of this Agreement, nor constitute a waiver or modification of any terms of this Agreement.

9. Audits

- 9.1 Except as may be otherwise specifically provided in this Agreement, either Party ("Auditing Party") may audit the other Party's ("Audited Party") records for the purpose of evaluating the accuracy of the Audited Party's bills and compliance with the terms and conditions of this Agreement. Such audits may be performed once in each Calendar Year for the most recent period of 12 full months ending within 60 days of the notice of audit; provided, however, that audits may be conducted more frequently (but no more frequently than once in each Calendar Quarter) if an immediately preceding audit found previously uncorrected net inaccuracies in billing in favor of the Auditing Party having an aggregate value of at least \$10,000 for any consecutive 12-month period.
- 9.2 All information reviewed or developed by the Auditing Party shall be considered to be Confidential Information that is subject to the provisions of Section 12 of this Agreement. The audit shall take place at a time and place agreed upon by the

Parties; provided, that the Auditing Party may require that the audit commence no later than sixty (60) days after the Auditing Party has given notice of the audit to the Audited Party.

- 9.3 Each Party shall cooperate fully in any such audit, providing reasonable access to any and all records reasonably necessary to assess the accuracy of the Audited Party's bills. Each Party shall correct previously uncorrected net inaccuracies revealed by an audit.
- 9.4 Audits shall be performed at the Auditing Party's expense, provided that there shall be no charge for reasonable access to the Audited Party's records, in the format in which such records are stored by the Audited Party, necessary to assess the accuracy of the Audited Party's bills, unless the auditors discover previously uncorrected net inaccuracies in billing in favor of the Auditing Party having an aggregate value of at least \$10,000 for any consecutive 12-month period, in which case the Audited Party shall reimburse the Auditing Party for the reasonable cost of the audit and any out-of-pocket expenses associated with the audit.

10. Authorization

- 10.1 BPS represents that it is a corporation duly organized, validly existing and in good standing under the laws of the State of Missouri and has full power and authority to execute and deliver this Agreement and to perform its obligations under this Agreement.
- 10.2 Big River represents that it is a limited liability company duly organized, validly existing and in good standing under the laws of the State of Delaware and has full power and authority to execute and deliver this Agreement and to perform its obligations under this Agreement.

11. Billing and Payment; Disputed Amounts

- 11.1 Except as otherwise provided in this Agreement, each Party shall bill the other Party on a monthly basis in an itemized format. The Parties shall also exchange billing information to process claims and adjustments as between themselves and on behalf of their Customers.
- 11.2 Except as otherwise provided in this Agreement, payment of amounts billed for Services provided under this Agreement, whether billed on a monthly basis or as otherwise provided in this Agreement, shall be due, in immediately available U.S. funds, within thirty (30) Calendar Days of the rendition of the invoice (the "Due Date"). If a Party does not receive a bill at least twenty (20) days prior to the Due Date, then the bill shall be considered delayed. When the bill has been delayed, the billed Party may request an extension of the payment Due Date, equal to the number of days the bill was delayed. Such requests for a delay of the payment Due Date must be in writing and accompanied with proof of late bill receipt.
- 11.3 If any portion of an amount billed by a Party under this Agreement is subject to a good faith dispute between the Parties, the billed Party shall give notice to the billing Party of the amounts it disputes ("Disputed Amounts") and include in such notice the specific details and reasons for disputing each item. Notice of a

dispute may be given by a Party at any time, either before or after an amount is paid, and a Party's payment of an amount shall not constitute a waiver of such Party's right to subsequently dispute its obligation to pay such amount or to seek a refund of any amount paid; provided, however, if the billed party fails to provide a notice of dispute within twelve (12) months of the payment Due Date for the amount in question, then the billed party shall be deemed to have waived any disputes as to those amounts (except as provided in Section 9). The billed Party shall pay by the Due Date all undisputed amounts. Billing disputes shall be subject to Dispute Resolution under the terms of this Agreement. If the billing dispute is resolved, in whole or in part, in favor of the billed Party, any credits and interest due to the billed Party as a result thereof shall be applied to the billed Party's account by the billing party during the next applicable billing cycle. If the billing dispute is resolved, in whole or in part, in favor of the billing Party, the billing Party will issue an invoice for the resolved amount due the billing Party and the billed Party will, within fifteen (15) days of the receipt of the invoice, make immediate payment of any withheld amounts and any late payment charges and interest, where applicable, to the billing Party. The dispute resolution procedures set forth in this Section shall also apply to disputes that may arise between the Parties regarding the origin of traffic for which one Party seeks compensation from the other Party under the terms of this Agreement.

- 11.4 Undisputed charges due to the billing Party that are not paid by the Due Date, shall be subject to a late payment charge. The late payment charge shall be in an amount specified by the billing Party which shall not exceed a rate of one-and-one-half percent (1.5%) of the overdue amount (excluding any unpaid previously billed late payment charges) per month.
- 11.5 Although it is the intent of both Parties to submit timely statements of charges, failure by either Party to present statements to the other Party in a timely manner shall not constitute a breach or default by the billing Party, or a waiver of the billing Party's right to payment of the incurred charges; provided however a Party shall not submit a statement of charges more than twelve (12) months after the date the services were provided.
- 11.6 All usage data and invoices to be provided pursuant to this Agreement shall be sent to the following addresses (unless the Party provides a change of address):

To BPS: Lisa Winberry
BPS Telephone Company
120 Stewart Street
P.O. Box 550
Bernie, MO 63822
Phone: 573-293-2277
Fax: 573-293-2299
Email: winberry@bpstelephone.com

To Big River:

Big River Telephone Company, LLC
24 S. Minnesota Ave.
Cape Girardeau, MO 63703
Phone: 573-651-3373
Fax: 573-651-3605
Email: jjennings@bigrivertelephone.com

12. Confidentiality

12.1 As used in this Section 12 "Confidential Information" means the following information that is disclosed by one Party ("Disclosing Party") to the other Party ("Receiving Party") in connection with this Agreement:

- i. Books, records, documents and other information disclosed or developed in an audit pursuant to Section 9 ("Audits");
- ii. Any forecasting information provided pursuant to this Agreement;
- iii. Customer Information (except to the extent that (a) the Customer information is published in a directory, (b) the Customer information is disclosed through or in the course of furnishing a Telecommunications Service, such as a Directory Assistance Service, Operator Service, Caller ID or similar service, or LIDB service, or, (c) the Customer to whom the Customer Information is related has authorized the Receiving Party to use and/or disclose the Customer Information);
- iv. Information related to specific facilities or equipment (including, but not limited to, cable and pair information);
- v. Any information that is in written, graphic, electromagnetic, or other tangible form, and marked at the time of disclosure as "Confidential" or "Proprietary;"
- vi. Any information that is communicated orally or visually; and
- vii. All orders (and related information) for any services placed by either Party pursuant to this Agreement, and information that would constitute Customer Proprietary Network Information of either Party's customers pursuant to the Act and the rules and regulations of the FCC, and call records and Recorded Usage Data whether disclosed by one Party to the other or otherwise acquired by either Party in the course of the performance of this Agreement, will be deemed Confidential Information of Disclosing Party for all purposes under this Agreement.

12.2 Notwithstanding any other provision of this Agreement, a Party shall have the right to refuse to accept receipt of Confidential Information, except to the extent that such information is required to fill an order for services provided under this Agreement.

12.3 Except as otherwise provided in this Agreement, the Receiving Party shall:

- i. Use the Confidential Information received from the Disclosing Party only in

performance of this Agreement, and only for the specific purpose for which the information was provided; and,

- ii. Using the same degree of care that it uses with similar confidential information of its own (but in no case a degree of care that is less than commercially reasonable), hold Confidential Information received from the Disclosing Party in confidence and restrict disclosure of the Confidential Information solely to those of the Receiving Party's Affiliates and the directors, officers, employees, Agents and contractors of the Receiving Party and the Receiving Party's Affiliates, that have a need to receive such Confidential Information in order to perform the Receiving Party's obligations under this Agreement. The Receiving Party's Affiliates and the directors, officers, employees, Agents and contractors of the Receiving Party and the Receiving Party's Affiliates, shall be required by the Receiving Party to comply with the provisions of this Section in the same manner as the Receiving Party. The Receiving Party shall be liable for any failure of the Receiving Party's Affiliates or the directors, officers, employees, Agents or contractors of the Receiving Party or the Receiving Party's Affiliates, to comply with the provisions of this Section.

12.4 The Receiving Party shall return or destroy all Confidential Information received from the Disclosing Party, including any copies made by the Receiving Party, within thirty (30) days after a written request by the Disclosing Party is delivered to the Receiving Party, except for any Confidential Information that the Receiving Party reasonably requires to perform its obligations under this Agreement, and shall certify to the Disclosing Party that the destruction has occurred.

12.5 Unless otherwise agreed, the obligations of this Section do not apply to information that:

- i. Was, at the time of receipt, already in the possession of or known to the Receiving Party free of any obligation of confidentiality and restriction on use;
- ii. Is or becomes publicly available or known through no wrongful act of the Receiving Party, the Receiving Party's Affiliates, or the directors, officers, employees, Agents or contractors of the Receiving Party or the Receiving Party's Affiliates;
- iii. Is rightfully received from a third person having no direct or indirect obligation of confidentiality or restriction on use to the Disclosing Party with respect to such information;
- iv. Is independently developed by the Receiving Party;
- v. Is approved for disclosure or use by written authorization of the Disclosing Party (including, but not limited to, in this Agreement); or
- vi. Is required to be disclosed by the Receiving Party pursuant to Applicable Law, provided that the Receiving Party shall promptly notify the Disclosing Party of the requirement in order to enable the Disclosing Party to seek protective arrangements.

- 12.6 Notwithstanding the provisions of this Section of the Agreement, the Receiving Party may use and disclose Confidential Information received from the Disclosing Party to the extent necessary to enforce the Receiving Party's rights under this Agreement or Applicable Law. In making any such disclosure, the Receiving Party shall make reasonable efforts to preserve the confidentiality and restrict the use of the Confidential Information while it is in the possession of any person to whom it is disclosed, including, but not limited to, by requesting any governmental entity to whom the Confidential Information is disclosed to treat it as confidential and restrict its use to purposes related to the proceeding pending before it.
- 12.7 The Disclosing Party shall retain all of the Disclosing Party's right, title and interest in any Confidential Information disclosed by the Disclosing Party to the Receiving Party. Except as otherwise expressly provided in this Agreement, no license is granted by this Agreement with respect to any Confidential Information (including, but not limited to, under any patent, trademark or copyright), nor is any such license to be implied solely by virtue of the disclosure of Confidential Information.
- 12.8 The provisions of this Section shall be in addition to and not in derogation of any provisions of Applicable Law, including, but not limited to, 47 U.S.C. § 222, and are not intended to constitute a waiver by a Party of any right provided by Applicable Law with regard to the use or protection of the confidentiality of CPNI.
- 12.9 Each Party's obligations under this Section shall survive the expiration, cancellation or termination of this Agreement for a period of two (2) years.

13. Counterparts

This Agreement may be executed in two or more counterparts, each of which shall be deemed an original and all of which together shall constitute one and the same instrument.

14. Default

- 14.1 If either Party (the "Defaulting Party") defaults in the payment of any amount due or violates any other provision of this Agreement, and such default or violation shall continue for thirty (30) days after written notice (the "Default Notice") thereof, the other Party (the "Aggrieved Party") may terminate this Agreement and services hereunder by written notice; provided, however, the Aggrieved Party has provided the Defaulting Party with written notice at least twenty-five (25) days (which shall not begin to run until after the 30 day period) prior to terminating service.
- 14.2 Such Default Notice shall be posted by overnight mail, return receipt requested. If the Defaulting Party cures the default or violation within the twenty-five (25) day period, the Aggrieved Party will not terminate service under this Agreement but shall be entitled to recover all reasonable costs, if any, incurred by it in connection with the default or violation, including, without limitation, reasonable costs incurred to prepare for the termination of service. For purposes of this Section 14, the terms "default", "violate", and "violation", in all of their forms, shall mean "materially default", "material default", "materially violate", or "material violation", as appropriate.
- 14.3 If the Defaulting Party disputes that the Aggrieved Party's notice of default or

believes the violations are justified by relevant facts, then the Parties shall address the disagreement pursuant to the processes set forth in Section 16 ("Dispute Resolution").

15. Discontinuance of Service

If a Party proposes to discontinue, or actually discontinues, its provision of service to Customers in the BPS service area, such Party shall provide notice of such discontinuance as required by Applicable Law.

16. Dispute Resolution

16.1 The Parties shall attempt to resolve any dispute between the Parties regarding the interpretation or enforcement of this Agreement or any of its terms by good faith negotiation between the Parties. To initiate such negotiation, a Party must provide to the other Party written notice of the dispute that includes both a detailed description of the dispute or alleged nonperformance and the name of an individual who has authority to resolve the dispute and will serve as the initiating Party's representative in the negotiation. The other Party shall have ten (10) Business Days to designate its own such representative in the negotiation. The Parties' representatives shall attempt to reach a good faith resolution of the dispute within thirty (30) days after the date of the initiating Party's written notice of the dispute. Upon mutual agreement, the Parties' representatives may utilize other alternative dispute resolution procedures such as private mediation to assist in the negotiations.

16.2 If the Parties are unable to resolve the dispute within thirty (30) days of the date of the initiating Party's written notice, either Party may pursue any remedies available to it under this Agreement, at law, in equity, or otherwise, including, but not limited to, instituting an appropriate proceeding before the Commission, the FCC, or a court of competent jurisdiction. Except for FCC actions, all such proceedings shall be initiated within the State of Missouri.

17. Force Majeure

17.1 Neither Party shall be responsible for any delay or failure in performance which results from causes beyond its reasonable control ("Force Majeure Events"), whether or not foreseeable by such Party. Such Force Majeure Events include, but are not limited to, adverse weather conditions, flood, fire, explosion, earthquake, volcanic action, power failure, embargo, boycott, war, revolution, civil commotion, act of public enemies, labor unrest (including, but not limited to, strikes, work stoppages, slowdowns, picketing or boycotts), acts of God, or any other circumstances beyond the reasonable control and without the fault or negligence of the Party affected.

17.2 If a Force Majeure Event occurs, the non-performing Party shall give prompt notification of its inability to perform to the other Party. During the period that the non-performing Party is unable to perform, the other Party shall also be excused from performance of its obligations to the extent such obligations are reciprocal to, or depend upon, the performance of the non-performing Party that has been prevented by the Force Majeure Event, including, but not limited to, payment of charges for services that were not performed due to the Force Majeure Event.

The non-performing Party shall use commercially reasonable efforts to avoid or remove the cause(s) of its non-performance and both Parties shall proceed to perform once the cause(s) are removed or cease.

17.3 Notwithstanding the provisions of Sections 17.1 and 17.2, although a Force Majeure event could result in delay of a payment obligation, in no case shall a Force Majeure Event excuse either Party from an obligation to pay money as required by this Agreement, except for any demand of payment for services not performed due to the Force Majeure Event.

17.4 Nothing in this Agreement shall require the non-performing Party to settle any labor dispute except as the non-performing Party, in its sole discretion, determines appropriate.

18. Forecasts

In addition to any other forecasts required by this Agreement, upon request by the Providing Party, the Purchasing Party shall provide forecasts regarding the Services that it expects to purchase, including, but not limited to, forecasts regarding the types and volumes of Services that it expects to purchase and the locations where such Services will be purchased. Such forecasts shall be considered to be Confidential Information under the terms of this Agreement, and distribution of the forecasts or information based on such forecasts shall be limited to those persons associated with the Providing Party who need to know such information in order to adequately provision the types and volumes of Services that the Purchasing Party expects to purchase at the locations where such Services will be purchased. The Providing Party may utilize the forecasts for planning purposes, but shall not be required to actually install facilities or otherwise provision in accordance with the forecasts unless and until the Purchasing party actually orders Service from the Providing Party.

19. Fraud

Neither party shall bear responsibility for, nor have any obligation to investigate or make adjustments to the other Party's account in cases of fraud by the other Party's Customers or other third parties; provided, however, that both Parties shall cooperate to discover and prevent fraud by each Party's Customers or other third parties.

20. Good Faith Performance

The Parties shall act in good faith in their performance of this Agreement. Except as otherwise expressly stated in this Agreement (including, but not limited to, where consent, approval, agreement or a similar action is stated to be within a Party's sole discretion), where consent, approval, mutual agreement or a similar action is required by any provision of this Agreement, such action shall not be unreasonably withheld, conditioned or delayed.

21. Headings

The headings used in the Agreement are inserted for convenience of reference only and are not intended to be a part of or to affect the meaning of the Agreement.

22. Indemnification

22.1 For the Services provided under this Agreement, each Party ("Indemnifying Party")

shall indemnify, defend and hold harmless the other Party, its Affiliates and their respective directors, officers, agents, contractors, and employees ("Indemnified Party"), from and against any and all Claims that arise out of bodily injury to or death of any person, or damage to, or destruction or loss of, tangible real and/or personal property, to the extent such injury, death, damage, destruction or loss, was caused by the gross negligence or intentionally wrongful acts or omissions of the Indemnifying Party, its Affiliates, or their respective directors, officers, employees, Agents or contractors (excluding the Indemnified Party).

22.2 An Indemnifying Party's obligations under this Section shall be conditioned upon the following:

- i. The Indemnified Party: (a) shall give the Indemnifying Party notice of the Claim promptly after becoming aware thereof (including a statement of facts known to the Indemnified Party related to the Claim and an estimate of the amount thereof); (b) prior to taking any material action with respect to the Claim, shall consult with the Indemnifying Party as to the procedure to be followed in defending, settling, or compromising the Claim; (c) shall not consent to any settlement or compromise of a Claim without the written consent of the Indemnifying Party, which consent shall not be unreasonable by withheld; (d) shall permit the Indemnifying Party to assume the defense of the Claim (including, except as provided below, the compromise or settlement thereof) at the Indemnifying Party's own cost and expense.
- ii. If the Indemnified Party fails to comply with the requirements of this Section with respect to a Claim, to the extent such failure shall have a material adverse effect upon the Indemnifying Party, the Indemnifying Party shall be relieved of its obligation to indemnify, defend and hold harmless the Indemnified Person with respect to such Claim under this Agreement.
- iii. The Indemnifying Party shall have the authority to defend and settle any Claim subject to the conditions set forth below.
 - a. With respect to any Claim, the Indemnified Party shall be entitled to participate with the Indemnifying Party in the defense of the Claim if the Claim requests equitable relief or other relief that could affect the rights of the Indemnified Party. In so participating, the Indemnified Person shall be entitled to employ separate counsel for such purposes at its own expense. The Indemnified Party shall also be entitled to participate, at its own expense, in the defense of any Claim, including any portion of the Claim as to which it is not entitled to be indemnified, defended and held harmless by the Indemnifying Party.
 - b. In no event shall the Indemnifying Party settle a Claim or consent to any judgment with regard to a Claim without the prior written consent of the Indemnified Party, which shall not be unreasonably withheld, conditioned or delayed.
 - c. The Indemnified Party shall, in all cases, assert any and all defenses, including, but not limited to, affirmative defenses and defenses set

forth in applicable Tariffs and Customer contracts of the Indemnified Party, that limit liability to third parties as a bar to, or limitation on, an Claim for damages by a third-party plaintiff.

- d. The Indemnifying Party and the Indemnified Party shall offer each other all reasonable cooperation and assistance in the defense of any Claim.

22.3 Except as otherwise provided above and consistent with Applicable Law, each Party agrees that it will not bring any action against the other Party, the other Party's Affiliates, or any of the directors, officers or employees, agents or contractors of the other Party or the other Party's Affiliates, based on any claim by any person for personal injury or death that occurs in the course or scope of employment of such person by the other Party or the other Party's Affiliate and that arises out of performance of this Agreement.

22.4 Each Party's obligations under this Section shall survive expiration, cancellation or termination of this Agreement for a period equal to the longest statute of limitations applicable to any Claim arising hereunder.

23. Intentionally Omitted.

24. Intellectual Property

24.1 Any intellectual property that originates from or is developed by a Party shall remain in the exclusive ownership of that Party. Intellectual property includes, without limitation, patent, copyright, trademark, trade secrets, and other proprietary rights. Each Party grants to the other Party, a limited license to its intellectual property solely to the extent necessary for the use of any facility or equipment (including software) or for the receipt of Services as provided under this Agreement. Except for such limited license to use its intellectual property, no license in patent, copyright, trademark or trade secret, or other proprietary or intellectual property right now or hereafter owned, controlled, or licensable by a Party, is granted to the other Party or shall be implied or arise by estoppel.

24.2 Big River acknowledges that its right under this Agreement may be subject to or limited by intellectual property rights and contract rights of third parties. BPS agrees to use its best efforts to obtain for Big River, third party intellectual property rights, under commercially reasonable terms, to enable Big River to receive the Services provided for under this Agreement.

24.3 BPS shall have no obligations to attempt to obtain for Big River any third party intellectual property right(s) that would permit Big River to use any unbundled network elements in a different manner than used by BPS.

24.4 All costs associated with the extension of third party intellectual property rights to Big River pursuant to this Section 24, including the cost of the license extension itself and the costs associated with the effort to obtain the license, shall be part of the cost of providing the Service to which the intellectual property rights relate and shall be paid by Big River.

24.5 BPS hereby conveys no licenses to use such third party intellectual property rights

and makes no warranties, express or implied, concerning Big River's rights with respect to such third party intellectual property rights and contract rights, including whether such rights will be violated by such Local Interconnection or unbundling and/or combining of network elements (including combining with Big River's use of other functions, facilities, products or services furnished under this Agreement). Any licenses or warranties for intellectual property rights are vendor licenses and warranties and are a part of the third party intellectual property rights BPS agrees in this Section 24 to use its best efforts to obtain.

25. Joint Work Product

The Agreement is the joint work product of the Parties, has been negotiated by the Parties, and shall be fairly interpreted in accordance with its terms.

26. Law Enforcement.

- 26.1 Each Party may cooperate with law enforcement authorities and national security authorities to the full extent required or permitted by Applicable Law in matters related to Services provided by it under this Agreement, including, but not limited to, the production of records, the establishment of new lines or the installation of new services on an existing line in order to support law enforcement and/or national security operations, and, the installation of wiretaps, trap-and-trace facilities and equipment, and dialed number recording facilities and equipment.
- 26.2 A Party shall not have the obligation to inform the other Party or the Customers of the other Party of actions taken in cooperating with law enforcement or national security authorities, except to the extent required by Applicable Law.
- 26.3 Where a law enforcement authorities or national security authorities request relates to the establishment of lines (including, but not limited to, lines established to support interception of communications on other lines), or the installation of other services, facilities or arrangements, a Party may act to prevent the other Party from obtaining access to such information concerning such lines, services, facilities and arrangements, through operations support system interfaces.

27. Liability

- 27.1 As used in this Section, "Service Failure" means a failure to comply with a direction to install, restore or terminate Services under this Agreement, a failure to provide Services under this Agreement, and failures, mistakes, omissions, interruptions, delays, errors, defects or the like, occurring in the course of the provision of any Services under this Agreement.
- 27.2 Except as otherwise stated in this Section, the liability, if any, of a Party, a Party's Affiliates, and the directors, officers and employees, agents and contractors of a Party and a Party's Affiliates, to the other Party, the other Party's Customers, and to any other person, for Claims arising out of a Service Failure shall not exceed an amount equal to the pro rata applicable monthly charge for the Services that are subject to the Service Failure for the period in which such Service Failure occurs.
- 27.3 For the Services provided under this Agreement, except as otherwise stated in this

Section, a Party, a Party's Affiliates, and the directors, officers and employees, agents and contractors of a Party and a Party's Affiliates, shall not be liable to the other Party, the other Party's Customers, or to any other person, in connection with this Agreement (including, but not limited to, in connection with a Service Failure or any breach, delay or failure in performance, of this Agreement) for special, indirect, incidental, consequential, reliance, exemplary, punitive, or like damages, including, but not limited to, damages for lost revenues, profits or savings, or other commercial or economic loss, even if the person whose liability is excluded by this Section has been advised of the possibility of such damages.

- 27.4 The limitations and exclusions of liability stated in this Section shall apply regardless of the form of a claim or action, whether statutory, in contract, warranty, strict liability, tort (including, but not limited to, negligence of a Party), or otherwise.
- 27.5 Nothing contained in this Section shall exclude or limit liability:
- 27.5.1 under Sections dealing with Indemnification, or, Taxes;
 - 27.5.2 for any obligation to indemnify, defend and/or hold harmless that a Party may have under this Agreement;
 - 27.5.3 for damages arising out of or resulting from bodily injury to or death of any person, or damage to, or destruction or loss of, tangible real and/or personal property of any person, or Toxic or Hazardous Substances, to the extent such damages are otherwise recoverable under Applicable Law;
 - 27.5.4 for a claim for infringement of any patent, copyright, trade name, trade mark, service mark, or other intellectual property interest;
 - 27.5.5 under Section 258 of the Act or any order of the FCC or the Commission implementing Section 258;
 - 27.5.6 under the financial incentive or remedy provisions of any service quality plan required by the FCC or the Commission; or,
 - 27.5.7 caused by the gross negligence or intentionally wrongful acts or omissions.
- 27.6 In the event that the liability of a Party, a Party's Affiliate, or a director, officer or employee, agent or contractor of a Party or a Party's Affiliate, is limited and/or excluded under both this Section and a provision of an applicable Tariff, the liability of the Party or other person shall be limited to the smaller of the amounts for which such Party or other person would be liable under this Section or the Tariff provision.
- 27.7 Each Party shall, in its tariffs and other contracts with its Customers, provide that in no case shall the other Party, the other Party's Affiliates, or the directors, officers or employees, agents or contractors of the other Party or the other Party's Affiliates, be liable to such Customers or other third persons for any special, indirect, incidental, consequential, reliance, exemplary, punitive or other damages, arising out of a Service Failure.

28. Network Management

- 28.1 Cooperation. The Parties will work cooperatively in a commercially reasonable manner to install and maintain a reliable network, and to ensure that Service is initiated and disconnected smoothly and without damage to the network or facilities of either Party. BPS and Big River will exchange appropriate information (e.g., network information, maintenance contact numbers, escalation procedures, and information required to comply with requirements of law enforcement and national security agencies) to achieve this desired reliability. In addition, the Parties will work cooperatively in a commercially reasonable manner to apply sound network management principles to alleviate and/or prevent traffic congestion.
- 28.2 Responsibility for Following Standards. Each Party recognizes a responsibility to follow the standards that may be agreed to between the Parties and to employ characteristics and methods of operation that will not interfere with or impair the service, network or facilities of the other Party or any third parties connected with or involved directly in the network or facilities of the other.
- 28.3 Interference or Impairment. If a Party ("Impaired Party") reasonably determines that the services, network, facilities, or methods of operation of the other Party ("Interfering Party") will or are likely to significantly degrade the Impaired Party's provision of services or the operation of the Impaired Party's network or facilities, the Impaired Party may interrupt or suspend service provided to the interfering party to the extent necessary to prevent such interference or impairment, subject to the following:
- i. The Impaired Party must notify the Interfering Party and allow that Party a reasonable opportunity, under the circumstances, to correct the problem.
 - ii. Where the Impaired Party does not know the precise cause of the interference or impairment, it must notify each Carrier that may have caused or contributed to the problem.
 - iii. Except in emergency situations (e.g., situations involving a risk of bodily injury to persons or damage to tangible property, or an interruption in Customer service) or as otherwise provided in this Agreement, the Impaired Party shall provide the Interfering Party at least ten (10) days' prior written notice of the interference or impairment or potential interference or impairment and the need to correct the condition within said time period;
 - iv. Where the interference or impairment asserted by the Impaired Party remains unresolved by the Interfering Party after ten (10) days, the Impaired Party must establish with specific and verifiable information that a particular service, network, facility or method of operation of the Interfering Party is causing the significant degradation.
 - v. Where the Impaired Party demonstrates that a particular service, network, facility or method of operation of the Interfering Party is significantly degrading the performance of the Impaired Party's provision of services,

the Interfering Party shall discontinue deployment of that service and correct the interference or impairment or migrate its Customers to technologies that will not significantly degrade the performance of other such services. Upon correction of the interference or impairment, the Impaired Party will promptly restore the interrupted or suspended Service. The Impaired Party shall not be obligated to provide an out-of-service credit allowance or other compensation to the Interfering Party in connection with the suspended Service unless Service was improperly interrupted or suspended by the Impaired Party.

- 28.4 Outage Repair Standard. In the event of an outage or trouble in any Service being provided by a Party hereunder, the Providing Party will follow industry standard procedures for isolating and clearing the outage or trouble in a manner consistent with its obligations to act in a non-discriminatory manner.

29. Notice of Network Changes

If a Party makes a change in the information necessary for the transmission and routing of services using that Party's facilities or network, or any other change in its facilities or network that will materially affect the interoperability of its facilities or network with the other Party's facilities or network, the Party making the change shall provide notice to the other Party of the change at least ninety (90) days in advance of such change; provided, however, that if an earlier publication of notice of a change is required by Applicable Law, notice shall be given at the time required by Applicable Law.

30. Notices

- 30.1 Except as otherwise provided in this Agreement, notices given by one Party to the other Party under this Agreement:

30.1.1 shall be in writing;

30.1.2 shall be delivered (a) personally, (b) by express delivery service with next Business Day delivery, or (c) by certified or registered U.S. mail, return receipt requested, postage prepaid; and

30.1.3 shall be delivered to the following addresses of the Parties:

To: Big River:

John F. Jennings
CFO
Big River Telephone Company, LLC
24 S. Minnesota Ave.
Cape Girardeau, MO 63703
Phone: 573-651-3373
Fax: 573-651-3605
Email: jjennings@bigrivertelephone.com

With a copy to:

Carl Lumley
CURTIS, HEINZ, GARRETT & O'KEEFE, P.C.
130 S. Bemiston, Suite 200
Clayton, Missouri 63105
Phone: (314) 725-8788
Fax: (314) 725-8789
Email: clumley@lawfirmemail.com

To: BPS Telephone Company

Lisa Winberry
BPS Telephone Company
120 Stewart Street
P.O. Box 550
Bernie, MO 63822
Phone: (573) 293-2277
Fax: (573) 293-2299
Email: winberry@bpstelephone.com

with a copy to:

W.R. England, III
BRYDON, SWEARENGEN & ENGLAND
312 East Capitol Avenue
Jefferson City, MO 65102
Phone: (573) 635-7166
Fax: (573) XXX-XXXX
Email: trip@brydonlaw.com

or to such other address(s) as either Party may designate from time to time by proper notice.

- 30.2 Notices will be deemed given as of the earlier of (a) where there is personal delivery of the notice, the date of actual receipt, (b) where the notice is sent via express delivery service for next Business Day delivery, the next Business Day

after the notice is sent or the date of actual receipt, whichever is later, and (c) where notice is sent via certified or registered U.S. mail, the date of receipt shown on the Postal Service receipt.

31. Performance Standards

31.1 Each Party shall provide Services under this Agreement in accordance with the standards required by this Agreement. For standards not specifically stated in this Agreement, Services provided under this Agreement will be provided in accordance with Applicable Law. And for those standards not covered in any Applicable Law, Services under this Agreement will be provided in accordance with industry standards.

31.2 This Section 31.2 applies only to those interconnection arrangements, Telecommunications Services, or other services, facilities or arrangements that one Party would not otherwise be required to provide to the other Party pursuant to this Agreement, Applicable Law or Tariff. To the extent that one Party requests (the "Requesting Party") of the other Party (the "Responding Party") any such Interconnection arrangement, Telecommunications Service, or other service, facility or arrangement for the exchange of Telecommunications traffic or any other Services pursuant to this Agreement and the fulfillment of that request would involve service or network arrangements beyond that which the Responding Party provides for its own services or beyond that which the Responding Party provides with any other carrier with which the Responding Party has an interconnection agreement, or which would require the Responding Party to incur extraordinary costs and/or expenses beyond that which the Responding Party incurs for its own services or beyond that which the Responding Party incurs for service arrangements with any other carrier with which it has an interconnection agreement, the Responding Party may, at its sole judgment and discretion and after full and proper notice to the Requesting Party, provide such superior arrangements under the condition that the Requesting Party shall be responsible for any additional costs or expenses that may arise for the provisioning and operation of such superior arrangements.

32. Point of Contact for Customers

32.1 Each Party shall establish telephone numbers and mailing addresses for purposes of communications with its Customers. Each Party shall advise its customers of these telephone numbers and mailing addresses. Each Party shall advise the other Party of these telephone numbers and mailing addresses.

32.2 Neither Party shall have any obligation to accept a communication from the other Party's Customer, including, but not limited to, a request by the other Party's Customer for repair or maintenance. To the extent the correct provider can be determined, misdirected calls received by either Party will be referred to the proper Service provider.

33. Publicity and Use of Trademarks or Service Marks

33.1 A Party, its Affiliates, and their respective contractors and Agents, shall not use the other Party's trademarks, service marks, logos or other proprietary trade dress, in connection with the sale of products or services, or in any advertising, press

releases, publicity matters or other promotional materials, unless the other Party has given its written consent for such use, which consent the other Party may grant or withhold in its sole discretion.

33.2 Neither Party may imply any direct or indirect affiliation with or sponsorship or endorsement of it or its services or products by the other Party.

34. References

34.1 All references to Sections, Attachments, or Appendices shall be deemed to be references to Sections, Attachments, and Appendices of this Agreement unless the context shall otherwise require.

34.2 Unless the context shall otherwise require, any reference to a Tariff, agreement, technical or other document, or provision of Applicable Law, is to such Tariff, agreement, document, or provision of Applicable Law, as amended and supplemented from time to time (and, in the case of a Tariff or provision of Applicable Law, to any successor Tariff or provision).

35. Relationship of the Parties

35.1 The relationship of the Parties under this Agreement shall be that of independent contractors and nothing herein shall be construed as creating any other relationship between the Parties.

35.2 Nothing contained in this Agreement shall make either Party the employee of the other, create a partnership, joint venture, or other similar relationship between the Parties, or grant to either Party a franchise, distributorship or similar interest.

35.3 Except for provisions herein expressly authorizing a Party to act for another Party, nothing in this Agreement shall constitute a Party as a legal representative or Agent of the other Party, nor shall a Party have the right or authority to assume, create or incur any liability or any obligation of any kind, express or implied, against, in the name or on behalf of the other Party unless otherwise expressly permitted by such other Party in writing, which permission may be granted or withheld by the other Party in its sole discretion.

35.4 Each Party shall have sole authority and responsibility to hire, fire, compensate, supervise, and otherwise control its employees, Agents and contractors. Each Party shall be solely responsible for payment of any Social Security or other taxes that it is required by Applicable Law to pay in conjunction with its employees, Agents and contractors, and for withholding and remitting to the applicable taxing authorities any taxes that it is required by Applicable Law to collect from its employees.

35.5 Except as otherwise expressly provided in this Agreement, no Party undertakes to perform any obligation of the other Party, whether regulatory or contractual, or to assume any responsibility for the management of the other Party's business.

35.6 The relationship of the Parties under this Agreement is a non-exclusive relationship.

36. Reservation of Rights

Notwithstanding anything to the contrary in this Agreement, neither Party waives, and each Party hereby expressly reserves, its rights: (a) to appeal or otherwise seek the reversal of and changes in any arbitration decision associated with any matter, including matters related specifically to this Agreement or other types of arrangements prescribed in this Agreement; (b) to seek changes in this Agreement (including, but not limited to, changes in rates, charges, and the Services that must be offered) through changes in Applicable Law; and (c) to challenge the lawfulness and propriety of, and to seek changes in, any Applicable Law, including, but not limited to, any rule, regulation, order, or decision of the Commission, the FCC, or a court of applicable jurisdiction, including challenges of or changes to matters related specifically to this Agreement or other types of arrangements prescribed in this Agreement. Nothing in the Agreement shall be deemed to limit or prejudice any position a Party has taken or may take before the Commission, the FCC, any other state or federal regulatory or legislative bodies, courts of applicable jurisdiction, or industry for addressing any matters, including matters related specifically to this Agreement or other types of arrangements prescribed by this Agreement. The provisions of the Section shall survive the expiration.

37. Subcontractors

A Party may use a contractor (including, but not limited to, an Affiliate of the Party) to perform the Party's obligations under this Agreement; provided, however, that a Party's use of a contractor shall not release the Party from any duty or liability to fulfill the Party's obligations under this Agreement.

38. Successors and Assigns

This Agreement shall be binding on and inure to the benefit of the Parties and their respective legal successors and permitted assigns.

39. Survival

The rights, liabilities and obligations of a Party for acts or omissions occurring prior to the expiration, cancellation or termination of this Agreement, the rights, liabilities and obligations of a Party under any provision of this Agreement regarding confidential information, indemnification or defense, or limitation or exclusion of liability, and the rights, liabilities and obligations of a Party under any provision of this Agreement which by its terms or nature is intended to continue beyond or to be performed after the expiration, cancellation or termination of this Agreement, shall survive the expiration, cancellation or termination of this Agreement for a period that coincides with the applicable statute of limitations established by Applicable Law.

40. Taxes

It is the mutual understanding of the Parties to this Agreement that there are no taxes specifically applicable to the subject matter of this Agreement or to either Party as a result of entering into this Agreement that would not otherwise be applicable to each respective Party. In the event that any government authority, however, determines to the contrary that a tax or taxes are applicable to the subject matter of this Agreement, then the following provisions will apply. In the event that any state or local excise, sales, or use taxes, if any (excluding any taxes levied on income), are applicable to the subject matter of this Agreement, then the Parties agree to negotiate mutually agreeable terms that will ensure that the tax obligation is met and that the taxes are properly collected and paid by the Parties. To the extent that the Parties cannot agree

on terms, then the Section 16 - Dispute Resolution process shall apply.

41. Technology Upgrades

41.1 Each Party (the "Providing Party") shall provide, maintain, repair or replace its facilities and Services, including those facilities and Services used by the other Party pursuant to this Agreement, at a level of quality that is equal to that which the Providing Party provides to itself, its Affiliates, and any third parties in accordance with the requirements of the Act. At a minimum, the Providing Party shall provide, maintain, repair or replace its facilities and Services in accordance with the same technical criteria and service standards that are used within its own network on terms and conditions that are just, reasonable and nondiscriminatory in accordance with the terms and conditions of this Agreement and Applicable Law.

41.2 Each Party shall have the right to deploy, upgrade, migrate and maintain its network to the extent permitted by Applicable Law. Nothing in this Agreement shall limit either Party's ability to modify its network through the incorporation of new equipment or software or otherwise.

42. Territory

42.1 This Agreement applies solely to the geographic territory in which BPS operates as an Incumbent Local Exchange Carrier in the state of Missouri.

43. Third Party Beneficiaries

Except as expressly set forth in this Agreement, this Agreement is for the sole benefit of the Parties and their legal successors and permitted assigns, and nothing herein shall create or be construed to provide any third-persons with any remedy, claim, liability, reimbursement, claim of action, or other right in excess of those existing by reference in this Agreement.

44. Filing of Agreement

The Parties understand and agree that this Agreement will be filed with the Commission.

45. 252(i) Obligations

To the extent required by law, each Party shall comply with section 252(i) of the Act.

46. Use of Service

Each Party shall make commercially reasonable efforts to ensure that its Customers, comply with the provisions of this Agreement (including, but not limited to the provisions of applicable Tariffs) applicable to the use of Services purchased by it under this Agreement.

47. No Waiver

Except as otherwise set forth in this Agreement, a failure or delay of either Party to enforce any of the provisions of this Agreement, or any right or remedy available under this Agreement or at law or in equity, or to require performance of any of the provisions of this Agreement, or to exercise any option which is provided under this Agreement, shall in no way be construed to be

a waiver of such provisions, rights, remedies or options. This Agreement is the result of voluntary negotiations between Local Exchange Carriers and shall be construed as an Agreement reached through voluntary negotiation.

48. Warranties

EXCEPT AS EXPRESSLY STATED IN THIS AGREEMENT, NEITHER PARTY MAKES OR RECEIVES ANY WARRANTY, EXPRESS OR IMPLIED, WITH RESPECT TO THE SERVICES PROVIDED, OR TO BE PROVIDED, UNDER THIS AGREEMENT AND THE PARTIES DISCLAIM ANY OTHER WARRANTIES, INCLUDING BUT NOT LIMITED TO, WARRANTIES OF MERCHANTABILITY, WARRANTIES OF FITNESS FOR A PARTICULAR PURPOSE WARRANTIES AGAINST INFRINGEMENT, AND WARRANTIES ARISING BY TRADE CUSTOM, TRADE USAGE, COURSE OF DEALING OR PERFORMANCE, OR OTHERWISE.

49. Entire Agreement

This Agreement and any Attachments, Appendices, or Tariffs which are incorporated herein by reference, sets forth the entire understanding and supersedes prior agreements between the Parties relating to the subject matter contained herein and merges all prior discussions between them, and neither Party shall be bound by any definition, condition, provision, representation, warranty, covenant or promise other than as expressly stated in this Agreement or as is contemporaneously or subsequently set forth in writing and executed by a duly authorized officer or representative of the Party to be bound thereby.

SIGNATURE PAGE

IN WITNESS WHEREOF, the Parties hereto have caused this Agreement to be executed as of the Effective Date.

BPS Telephone Company

Big River Telephone Company, LLC

By: W. F. Provance

By: Gerard J Howe

Printed: W. F. Provance

Printed: GERARD J HOWE

Title: President

Title: CEO

Date: Jan 11, 2008

Date: JAN 10, 2008

ATTACHMENT A
GLOSSARY OF TERMS

1. General Rule

Unless the context clearly indicates otherwise, when a term listed in this Glossary is used in this Agreement, the term shall have the meaning stated in this Glossary. A defined term intended to convey the meaning stated in this Glossary is capitalized when used. Certain other terms that are capitalized, and not defined in this Glossary or elsewhere in this Agreement, shall have the meaning stated in the Act. Additional definitions that are specific to the matters covered in a particular provision of this Agreement may appear in that provision. To the extent that there may be any conflict between a definition set forth in this Glossary and any definition in a specific provision, the definition set forth in the specific provision shall control with respect to that provision. The Parties acknowledge that other terms appear in this Agreement that are not defined or ascribed as described above. The Parties agree that any such terms shall be construed in accordance with their customary usage in the telecommunications industry as of the effective date of this Agreement.

Unless the context clearly indicates otherwise, any term defined in this Glossary which is defined or used in the singular shall include the plural, and any term defined in this Glossary which is defined or used in the plural shall include the singular.

2. Definitions

- 2.1 "Access Services" refers to interstate and intrastate switched access and private line transport services.
- 2.2 "Act" means the Communications Act of 1934 (47 U.S.C. §151 et seq.), as amended from time to time (including, but not limited to, by the Telecommunications Act of 1996).
- 2.3 "Affiliate" shall have the meaning set forth in the Act.
- 2.4 "Agent" shall include an agent or servant.
- 2.5 "Agreement" means this Agreement, as defined in Part B, Section 1 of the General Terms and Conditions.
- 2.6 "Ancillary Traffic" means all traffic that is destined to provide Services ancillary to Telecommunications Services, or that may have special routing or billing requirements, including but not limited to the following: 911/E911, Operator Services, Directory Assistance, third party (except for that third party traffic that is specifically addressed in this Agreement), collect and calling card database query and Service, 800/888 database query and Service, CNAM, LIDB, and voice information Service.
- 2.7 "Applicable Law" means all effective laws, administrative rules and regulations, and any court orders, rulings and decisions from courts of competent jurisdiction, applicable to each Party's performance of its obligations under this Agreement.

- 2.8 "Business Day" means Monday through Friday, except for BPS's holidays.
- 2.9 "Calendar Quarter" means January through March, April through June, July through September, or October through December
- 2.10 "Calendar Year" means January through December.
- 2.11 "Calling Party Number" or "CPN" means a CCS parameter that identifies the calling party's telephone number.
- 2.12 "Central Office" or "CO" refers to a local switching system for connecting lines to lines, lines to trunks, or trunks to trunks for the purpose of originating/terminating calls over the public switched telephone network. A single Central Office may handle several Central Office codes ("NXXs"). Sometimes this term is used to refer to a telephone company building in which switching systems and telephone equipment are installed.
- 2.13 "Central Office Switch" refers to a switch used to provide Telecommunications Services, including, but not limited to, End Office and Tandem Switches. A Central Office Switch may also be employed as a combination End Office/Tandem Office Switch.
- 2.14 "Commission" shall mean the Missouri Public Service Commission.
- 2.15 "Common Channel Signaling" or "CCS" refers to a method of transmitting call set-up and network control data over a digital signaling network separate from the public switched telephone network facilities that carry the actual voice or data content of the call. The CCS currently used by the Parties is SS7.
- 2.16 "Common Language Location Identifier" or "CLLI Code" refers to a code developed by Telcordia Technologies as a method of identifying physical locations and equipment such as buildings, Central Offices, poles and antennas. There are three (3) basic formats for CLLI Codes: network entity, network support site, and customer site.
- 2.17 "Competitive Local Exchange Carrier" or "CLEC" refers to any Local Exchange Carrier providing Local Exchange Telecommunications Service in any area where it is not an Incumbent Local Exchange Carrier ("ILEC").
- 2.18 "Customer" or "End User" means the residential or business subscriber that is the ultimate end user of Telephone Exchange Services provided by either of the Parties.
- 2.19 "Customer Proprietary Network Information" or "CPNI" is as defined in the Act.
- 2.20 "Day" means calendar days unless otherwise specified.
- 2.21 "End Office Switch" or "End Office" means a switching entity that is used to terminate Customer station Loops for the purpose of interconnection to each other and to trunks.

- 2.22 "Enhanced Services" shall mean services offered over common carrier transmission facilities used in interstate communications, which employ computer processing applications that act on the format, content, code, protocol or similar aspects of the Customer's transmitted information; provide the Customer with additional, different, or restructured information; or involve Customer interaction with stored information.
- 2.23 "Enhanced Service Provider" or "ESP" shall mean a provider of Enhanced Services.
- 2.24 "Entrance Facility" shall mean the facilities between a Party's designated premises and the Central Office serving that designated premises.
- 2.25 "FCC" shall mean the Federal Communications Commission.
- 2.26 "Foreign Exchange Service" is a tariffed local exchange service whereby a Customer who is located in one Rate Center Area ("Home Exchange Area") obtains local exchange service in a different rate Center Area ("Foreign Exchange Area"). Tariffed Foreign Exchange Service provides the Customer with a private line interexchange circuit to the Customer's Home Exchange Area location to the Customer's Foreign Exchange Area and local exchange service in the Foreign Exchange Area. The Customer is assigned a telephone number associated with the Foreign Exchange Area must be both within the same LATA and within the state of Missouri.
- 2.27 "Incumbent Local Exchange Carrier" or "ILEC" shall have the meaning stated in the Act.
- 2.28 "Interexchange Carrier" or "IXC" means a Telecommunications Carrier that provides, directly or indirectly, InterLATA or IntraLATA Telephone Toll Services.
- 2.29 "Internet" means the collective international network of interoperable public, private, managed and non-managed computer and Telecommunications facilities, including both hardware and software, which comprise the interconnected world-wide network of networks that employ the Transmission Control Protocol/Internet Protocol (TCP/IP), or any predecessor or successor protocols to such protocol, to communicate information of all kinds by wireline or wireless connections.
- 2.30 "Internet Protocol" refers to a standard networking protocol that provides information transmission across interconnected networks, between computers with diverse hardware architectures and various operating systems, and keeps track of Internet addresses for different nodes, routes outgoing information and recognizes incoming information.
- 2.31 "Internet Service Provider" or "ISP" is a vendor who provides access for Customers (companies and private individuals) to the Internet and the World Wide Web for Telecommunication Services or other means, but does not include a common carrier to the extent that it provides common carrier services.

- 2.32 "Internet Traffic" or "ISP Bound Traffic" means dial-up ISP traffic that is originated and dialed by an End User of one Party, delivered to the other Party, and terminated by the other Party to an ISP.
- 2.33 "IntraLATA Traffic" means telecommunications traffic that originates and terminates within the same LATA.
- 2.34 "Interconnection Point" or "IP" means the location on the incumbent LEC network of BPS at which the connection is made by Big River for the exchange of Local Traffic between the Parties.
- 2.35 "Listing Information" shall mean a Customer's primary name, address (including city, state, and zip code), telephone number(s), the delivery address and the number of directories to be delivered, and, in the case of a business Customer, the primary business heading under which the business Customer desires to be placed, and any other information both parties agree to be included in the publication and delivery of directories.
- 2.36 "Local Access and Transport Area" or "LATA" shall have the meaning set forth in the Act.
- 2.37 "Local Calling Area" shall mean the local serving exchange area as defined by the effective local exchange tariff(s) of BPS, in addition to areas contained within exchanges that are included in non-optional Extended Area Service plans contained in the effective local exchange tariff(s) of BPS and any other areas included by mandatory local calling scope arrangements established and defined by the Commission.
- 2.38 "Local Exchange Carrier" or "LEC" shall have the meaning set forth in the Act.
- 2.39 "Local Exchange Routing Guide" or "LERG" shall mean a Telcordia Technologies reference containing NPA/NXX routing and homing information.
- 2.40 "Local Internet Traffic" means Internet Traffic or ISP Bound Traffic that terminates to an NXX code assigned to the same local serving area, including mandatory local calling scope arrangements as the NXX code of the calling End User. A mandatory local calling scope arrangement is an arrangement that provides End Users a local calling scope; i.e. Extended Area Service ("EAS"), beyond the End User's basic exchange serving area. Notwithstanding the foregoing, Local Internet Traffic does not include Internet Traffic or ISP Bound Traffic that originates from a Party's End-User and terminates to an ISP located in an exchange served by a third-party carrier regardless of whether said third party carrier's exchange is included within BPS's mandatory expanded local calling scope.
- 2.41 "Local Number Portability" ("LNP") means the ability of Customers of Telecommunications Services to retain, within the same geographic Rate Center Area associated with the Customer's NPA-NXX code, existing telecommunications numbers without impairment of quality, reliability, or convenience when switching from one telecommunications carrier to another.

- 2.42 "Local Service Request" ("LSR") means an industry standard form or a mutually agreed upon change thereof, used by the Parties to add, establish, change or disconnect local services.
- 2.43 "Local Traffic" or "Subject Traffic" means traffic that is originated by an End User of one Party on that Party's network and terminates to an End User of the other Party on that other Party's network within BPS's local serving area as defined by the effective local exchange tariff(s) of BPS, including mandatory local calling scope arrangements and including Foreign Exchange ("FX") Service provided in accordance with approved tariffs. A mandatory local calling scope arrangement is an arrangement that provides End Users a local calling scope; i.e. Extended Area Service ("EAS"), beyond the End User's basic exchange serving area. Therefore Local Traffic, for purposes of this Agreement, includes both intra-exchange calls and non-optional EAS calls, but does not include any optional extended local scope service arrangement. For this purpose, Local Traffic does not include any ISP-Bound Traffic.
- 2.44 "North American Numbering Plan" ("NANP") means the plan for the allocation of unique 10-digit directory numbers consisting of a three-digit area code, a three-digit office code, and a four-digit line number. The plan also extends to format variations, prefixes, and special code applications.
- 2.45 "Numbering Plan Area ("NPA")" (sometimes referred to as an area code) is the three-digit indicator which is designated by the first three digits of each 10-digit telephone number within the NANP. Each NPA contains 800 possible NXX Codes. There are two general categories of NPA, "Geographic NPAs" and "Non-Geographic NPAs." A "Geographic NPA" is associated with a defined geographic area, and all telephone numbers bearing such NPA are associated with services provided within that geographic area. A "Non-Geographic NPA," also known as a "Service Access Code (SAC Code)" is typically associated with a specialized telecommunications service which may be provided across multiple geographic NPA areas; 500, 800, 900, 700, and 888 are examples of Non-Geographic NPAs.
- 2.46 "NXX," "NXX Code," "NNX," "COC," "Central Office Code," or "CO Code" is the three-digit switch entity indicator which is defined by the fourth, fifth and sixth digits of a 10-digit telephone number within NANP.
- 2.47 "Primary Listing" shall mean a Customer's primary name, address, and telephone number.
- 2.48 "Proprietary Information" shall have the same meaning as Confidential Information, which is defined in Section 12 of the General Terms and Conditions.
- 2.49 "Providing Party" means a Party offering or providing a Service to the other Party under this Agreement.
- 2.50 "Purchasing Party" means a Party requesting or receiving a Service from the other Party under this Agreement.

- 2.51 "Rate Center Area" refers to the geographic area that has been identified as being associated with a particular NPA-NXX code assigned to the LEC for its provision of Telephone Exchange Services. The Rate Center Area is the exclusive geographic area that the LEC has identified as the area within which it will provide Telephone Exchange Services bearing the particular NPA-NXX designation associated with the specific Rate Center Area.
- 2.52 "Rate Center Point" refers to a specific geographic point, defined by a V&H coordinate, located within the Rate Center Area and used to measure distance for the purpose of billing for distance-sensitive Telephone Exchange Services and Toll Traffic.
- 2.53 "Reciprocal Compensation" means the arrangement for recovering, in accordance with Section 251(b)(5) of the Act, costs incurred for the transport and termination of Subject Traffic originating by the Customers of one Party on that Party's network and terminating to the Customers of the other Party on that other Party's network.
- 2.54 "Service" means any Interconnection arrangement, Telecommunications Service, or other service, facility or arrangement, offered by a Party under this Agreement.
- 2.55 "Signaling System 7" or "SS7" refers to the common channel out-of-band signaling protocol (CCS) developed by the Consultative Committee for International Telephone and Telegraph (CCITT) and the American National Standards Institute (ANSI). Big River and BPS currently utilize this out-of-band signaling protocol.
- 2.56 "Subject Traffic" – See "Local Traffic".
- 2.57 "Subsidiary" means a corporation or other person that is controlled by a Party.
- 2.58 "Switched Exchange Access Service" means the offering of transmission and switching services for the purpose of the origination or termination of Toll Traffic. Switched Exchange Access Services include but may not be limited to: Feature Group A, Feature Group B, Feature Group C, Feature Group D, 700 access, 800 access, 888 access and 900 access.
- 2.59 "Synchronous Optical Network ("SONET") is an optical interface standard that allows interworking of transmission products from multiple vendors (i.e., mid-span meets). The base rate is 51.84 Mbps (OC-1/STS-1 and higher rates are direct multiples of the base rate up to 1.22 Gbps).
- 2.60 "Tariff" means a filing made at the state or federal level for the provision of a telecommunications service by a telecommunications carrier that provides for the terms, conditions and pricing of that service. Such filing may be required or voluntary and may or may not be specifically approved by the Commission or FCC.
- 2.61 "Telcordia Technologies" refers to Telcordia Technologies, Inc., formerly known as Bell Communications Research, Inc. (Bellcore).

- 2.62 "Telecommunications" is as defined in the Act.
- 2.63 "Telecommunications Carrier" shall have the meaning set forth in the Act.
- 2.64 "Telecommunications Services" shall have the meaning set forth in the Act.
- 2.65 "Voice over Internet Protocol Traffic" or "VOIP Traffic" is voice communications traffic that utilizes Internet Protocol format for some or all of the transmission of the call.

ATTACHMENT B

ADDITIONAL SERVICES

The Services described in this Attachment B shall only be available to Big River under this Agreement: (i) when BPS is providing the Service to itself, (ii) in areas where BPS is providing such Service to BPS's end-user subscribers (except for dialing parity and Local Number Portability), and (iii) subject to the limitations specified herein. To the extent that BPS does not provide the Services described in this Attachment B to itself or if the requested Service is not available to BPS's end-user subscribers, Big River must secure any desired Services under a separate agreement with BPS or with another provider.

1. Dialing Parity - Section 251(b)(3)

Each Party shall provide the other Party with nondiscriminatory access to such services and information as are necessary to allow the other Party to implement local Dialing Parity in accordance with the requirements of Section 251(b)(3) of the Act.

2. Directory Listing and Directory Distribution

BPS will provide directory listing services to Big River. Big River will receive for its retail end users, one primary listing in BPS' White Pages Directory and a listing in BPS' directory listing data base. Such services will be provided in accordance with the terms set forth herein.

2.1 Listing Information Supply

2.1.1 The Parties will cooperate in the development of a suitable timetable for the submission of Customer Listing Information for inclusion of the appropriate BPS directory. Big River will provide Customer Listing Information to BPS (or its contract directory publisher) in such format as is consistent with a base file subscriber list format normally provided to publishers of directories. Big River agrees to provide base file list information to BPS in a comma delimited, mechanized, electronic format.

2.1.2 The foregoing notwithstanding, Big River will not provide directory Listing Information to BPS for non-published telephone numbers. Big River understands that BPS will have no ability to provide such unlisted directory Listing Information to any third parties and BPS may not deliver published directories to Big River's Customers with non-published telephone numbers.

2.2 Listing Inclusion and Distribution

Subject to the terms, conditions, and rates of its directory publishing agreement, BPS shall include, on a nondiscriminatory basis and consistent with any obligations it may have under Applicable Law, at no charge, each Big River Customer's Primary Listing in all appropriate alphabetical directories (both print and electronic) and, for business Customers, in the appropriate classified (Yellow Pages) directories in accordance with the directory configuration, scope and schedules determined by BPS in its sole

discretion; provided, however, that BPS may charge extra for foreign listings placed by Big River's customers in one or more of BPS's directories. BPS shall provide initial distribution of directories to Big River Customers in the same manner BPS provides initial distribution of such directories to its own Customers. Listings of Big River's Customers shall be interfiled with listings of BPS' Customers and the Customers of other LECs included in the BPS directories.

2.3 BPS Information

Upon request by Big River, BPS shall make available to Big River the following information to the extent that BPS provides such information to its own business offices: a directory list of relevant NXX codes, directory close dates, publishing data, and Yellow Pages headings. BPS also will make available to Big River, upon written request, a copy of BPS' alphabetical listings standards and specifications manual.

2.4 Confidentiality of Listing Information

BPS shall accord Big River Listing Information the same level of confidentiality that BPS accords its own listing information, and shall use such Listing Information solely for the purpose of providing directory-related services; provided, however, BPS may not use or license Big River Listing Information for directory publishing by third parties or any other purpose beyond the purposes specifically outlined in this Section 2 without the written permission of Big River.

2.5 Accuracy

Both Parties shall use commercially reasonable efforts to ensure the accurate publication of Big River Customer listings. Subject to the terms and conditions of its directory publishing agreement, at Big River's request, BPS shall provide Big River with a report, in a format specified by BPS, of all Big River's Customer listings BPS shall process any corrections made by Big River with respect to its listings, if such corrections are received prior to the close date of the particular directory. Big River shall pay BPS for the listing reports at the rates set forth in the Pricing Attachment.

2.6 Indemnification

Big River shall adhere to all practices, standards, and ethical requirements established by BPS with regard to listings. By providing BPS with Listing Information, Big River represents to BPS that Big River has the right to provide such Listing Information to BPS on behalf of Big River's Customers for publishing in BPS' directories provided to the public. Big River agrees to release, defend, hold harmless and indemnify BPS from and against any and all claims, losses, damages, suits, or other actions, or any liability whatsoever, including costs of suit and reasonable attorneys fees, suffered, made, instituted, or asserted by any person arising out of BPS' publication or dissemination of the Listing Information as provided by Big River hereunder.

2.7 Liability

BPS' liability to Big River in the event of a BPS error in or omission of a listing shall not exceed the lesser of the amount of charges actually paid by Big River for such listing or

the amount by which BPS would be liable to its own Customer.

2.8 Directory Publication

Nothing in this Agreement shall require BPS to publish a directory where it would not otherwise do so.

3. Intercept and Referral Announcements

3.1 When a Customer changes its service provider from BPS to Big River, or from Big River to BPS, and does not retain its original telephone number, the Party formerly providing service to such Customer shall provide a referral announcement ("Referral Announcement") on the abandoned telephone number which provides the Customer's new number or other appropriate information, to the extent known to the Party formerly providing service. Notwithstanding the foregoing, a Party shall not be obligated under this Section to provide a Referral Announcement if the Customer owes the Party unpaid overdue amounts or the Customer requests that no Referral Announcement be provided.

3.2 Referral Announcements shall be provided for a period of time for business Customers and residential Customers in accordance with the same time period and terms specified in BPS' tariff and/or pursuant to BPS' general business practices. Except as otherwise provided by Applicable Law, the period for a referral may be shortened by the Party formerly providing service if a number shortage condition requires reassignment of the telephone number. This referral announcement will be provided by each Party at no charge to the other Party; provided that the Party formerly providing service may bill the Customer its standard Tariff charge, if any, for the referral announcement.

4. Resale of Retail Telecommunications Services

4.1 General Requirements

4.1.1 At the request of either Party, and pursuant to the requirements of the Act, any telecommunications service that one Party currently provides or hereafter provides at retail to subscribers who are not telecommunications carriers will be made available to the other Party by the providing Party in accordance with the terms and conditions set forth in this Section.

4.1.2 The Parties agree that a LEC has the duty not to prohibit, and not to impose unreasonable or discriminatory conditions or limitations on, the resale of its telecommunication service pursuant to 251(b)(1) of the Act.

4.1.3 The providing Party will apply an End User Common Line (EUCL) charge to each local exchange line resold under this agreement. All federal rules and regulations associated with EUCL charges, as found in the providing Party's FCC Tariff, also apply.

4.1.4 Each Party will make available to the other Party for resale the following services in accordance with the providing Party's tariffed terms,

conditions, and rates for each service:

- Construction Charges
- Suspension Services/Restoral Services

4.1.5 Telecommunications Services will be resold by one Party to the other Party on terms and conditions that are reasonable and nondiscriminatory, and, to the extent those Services are tariffed, the tariffed terms, conditions, and rates will apply.

4.1.6 Directory Assistance and Operator Services (Available to Resale Customers Only)

Subject to any blocking that may be ordered by Big River for its customers, to the extent Directory Assistance services are provided to BPS' customers, BPS shall provide Big River's customers access to BPS' Directory Assistance services.

4.1.7 Subject to any blocking that may be ordered by Big River for its customers, BPS will provide access to Operator Services ("OS") to Big River's customers to the same extent it provides OS to its own customers. Unless otherwise provided in this Agreement, BPS will perform all of its obligations hereunder throughout the entire service area where BPS is the incumbent local exchange carrier. BPS will provide the services covered by this Attachment subject to the availability of facilities in this state.

4.1.8 Big River may at any time add or delete features to or relocate the Resale services for Big River's customers except for grandfathered services. However, Big River may only offer grandfathered services to customers that are eligible to receive grandfathered services from BPS.

4.1.9 Big River may terminate any Resale service within the period specified for termination of such Resale service in BPS' tariff applicable to that service, unless a different period is specified in this Section.

4.2 Pricing

Service provided under the Resale arrangement as outlined in this Section 4, will be priced at a 10% discount to the providing Party's tariffed rates.

ATTACHMENT C

INTERCONNECTION AND NUMBER PORTABILITY

This Attachment describes the arrangements between the Parties for interconnection and the transmission and routing of telecommunications traffic as set forth below.

1. Scope of Traffic

- 1.1 The Parties agree that they will deliver to each other over the interconnection facilities the following traffic: (1) Local Traffic and (2) Local Internet Traffic.
- 1.2 Each Party agrees that it will not provision any of its services in a manner that will result in, or that permits, the circumvention of the application of intrastate or interstate access charges by the other Party including, but not limited to, the resale to third parties or the assignment of NPA-NXX numbers associated with one Rate Center for Customers that obtain local exchange service in a different Rate Center. Telecommunications traffic to or from Customers that originates or terminates in areas other than those included in the calling scope of Local Traffic is beyond the scope of the Agreement, except in the case of Foreign Exchange ("FX") service provided in accordance with approved tariffs. All traffic that does not originate and terminate to Customers within the same local calling area of either Party, excluding tariffed FX service, is subject to intrastate or interstate Switched Exchange Access Service tariffs regardless of whether the traffic may have been transmitted via Internet Protocol or any other transmission protocol at any time during the routing and transmission of the call.
- 1.3 Both Parties warrant that they will: (a) assign telephone numbers to Customers that obtain local exchange service in the Rate Center Areas associated with the telephone number in a manner consistent with this Agreement; (b) provision their local exchange carrier services in a manner that the resulting traffic exchanged between the Parties pursuant to this Agreement will be confined to the scope of the traffic as set forth in this Section; (c) adopt the Rate Center areas for the assignment of telephone numbers that are identical to those used by the incumbent local exchange carriers that serve the Local Service Exchange Areas related to the Local Traffic exchanged pursuant to this Agreement; (d) assign whole NXX Codes to each Rate Center, or where, applicable, thousand number blocks within a NXX Code assigned to that Rate Center; and (e) subject to section 4.2 below, provide Calling Party Number on Customer originated traffic delivered to the other Party. Both Parties agree that they will engineer their respective networks and design their respective systems to deliver traffic in compliance with this Agreement.
- 1.4 If either Party violates Section 1.2 or 1.3 above, the other Party shall be entitled to charge originating and terminating access charges as prescribed by applicable tariff, for traffic associated with such violations.
- 1.5 Both Parties agree only to deliver traffic to the other Party pursuant to and consistent with the terms of this Agreement.
- 1.6 Each Party is solely responsible for the receipt and transmission of 911/E911

traffic originated by its End Users of its Telephone Exchange Services. The Parties acknowledge and affirm that calls to 911/E911 services shall NOT be routed over the trunk groups established between the Parties pursuant to this Agreement. To the extent that a Party incorrectly routes such traffic over such arrangements, that Party shall fully indemnify and hold harmless the other Party, in accordance with the terms of this Agreement, for any claims, including claims of third parties, related to such calls.

2. Methods for Interconnection and Trunk Types

2.1 Methods for Interconnection.

2.1.1 Interconnection

2.1.1.A The Parties shall utilize the IP(s) designated as the points from which the Parties will provide transport and termination of traffic that is within the scope of the Agreement. Each Party will be responsible operationally and financially for bringing their facilities to the IP and for the delivery to the IP of any traffic that the Party sends to the other Party under the terms of this Agreement. Where mutually beneficial to the Parties, they may agree to provision voluntary arrangements not otherwise required under Applicable Law.

2.1.1.B The Parties agree to interconnect at one or more IPs as set forth in Appendix A in accordance with the following options:

1. The Parties may interconnect at a mid-span meet point subject to the following terms, conditions and provisions:

- (a) The mid-span meet point, as proposed, must be technically and economically feasible and shall be subject to reasonable engineering, environmental, safety and security requirements. Such requirements shall include, without limitation, the technical ability to accommodate testing on each side of the mid-span meet point and to provide for a point of demarcation between the networks of each party;
- (b) The mid-span meet point must be located on the incumbent network of BPS and within or at BPS's exchange boundary;
- (c) The location, equipment and work needed to establish the mid-span meet point shall be subject to mutual agreement of the Parties;

2. Any other mutually-agreed to arrangement, as negotiated by the Parties.

2.1.1.C Each Party shall provide its own facilities or purchase necessary transport for the provisioning of facilities to the agreed-to IP(s).

2.1.1.D Indirect Interconnection. Big River shall be permitted to use a third party carrier's facilities for purposes of establishing interconnection indirectly with BPS at the IP(s). In such case, on behalf of Big River, the third party carrier will connect its facilities with BPS at the IP(s). Big River shall be responsible for the payment to any third party carrier for any charges associated with the facilities. Big River will also be responsible for charges associated with any non-Local Traffic that may be transported on BPS' facilities as a result of Big River's use of a third party carrier for interconnection.

2.1.2 The Parties shall utilize the common channel out-of-band signaling ("CCS") protocol developed by the Consultative Committee for International Telephone and Telegraph ("CCITT") and the American National Standards Institute ("ANSI"). The Parties currently utilize SS7 out-of-band signaling protocol and agree to continue to exchange traffic using SS7 signaling parameters including, but not limited to ISDN User Part ("ISUP"), Signaling Points including STPs, SSPs, and SCPs, and any other SS7 parameters necessary for the exchange of traffic.

2.1.2.A The Parties agree to cooperate on the exchange of all appropriate SS7 messages for call set-up, including ISUP and Transaction Capability User Part ("TCAP") messages, to facilitate full interoperability of all CLASS features and functions between their respective networks. The parties shall include the Jurisdiction Information Parameter ("JIP") in the Initial Address Message ("IAM"), containing a Local Exchange Routing Guide-assigned NPA-NXX (6 digits) identifying the originating switch on calls that they originate

2.1.2.B Neither Party shall intentionally substitute or generate incorrect ANI, CPN or SS7 parameters on traffic exchanged pursuant to this Agreement. Upon determination that a Party has intentionally substituted or generated such incorrect parameters on traffic exchanged pursuant to this Agreement, the offending Party shall pay the other Party the difference between compensation paid (if any) and applicable access charges, plus interest due under the terms of the applicable access tariff from the date the traffic would have been billed if such parameters had been passed unaltered

2.2 Trunking Arrangements

2.2.1 The Parties will interconnect one or more trunk groups for the transmission and routing of Local Traffic and Local Internet Traffic as set forth in Appendix A.

2.2.2 For each trunk group with a utilization level of less than sixty percent

(60%) for three consecutive months, unless the Parties agree otherwise, either Party may disconnect a sufficient number of the available trunks to attain a utilization level of approximately sixty percent (60%); provided, however, the trunks will be grouped in multiples of 24 trunks for the purpose of determining utilization levels. The minimum utilization level of sixty percent (60%) is not required until trunk groups have been in service for at least six (6) months.

- 2.2.3 All trunks shall utilize SS7 Common Channel Signaling. The Parties agree to utilize B8ZS and Extended Super Frame (ESF) DS1 facilities, where available.
- 2.2.4 The Parties shall meet (telephonically or in person) from time to time, as needed, to review data on two-way trunks to determine the need for new trunk groups and to plan any necessary changes in the number of trunks.
- 2.2.5 The trunk group(s) established between the Parties pursuant to the terms of this Agreement for the exchange of Local Traffic and Local Internet Traffic shall be engineered to a P.01 Grade of Service. The performance standard for two-way trunk groups shall be that no such trunk group will exceed its design blocking objective for three (3) consecutive calendar traffic study months.
- 2.2.6 The Parties shall collaboratively determine the number of two-way trunks that are required to meet the applicable design-blocking objective for all traffic carried on each two-way trunk group. Big River shall order two-way trunks by submitting ASRs to BPS and any applicable third party, setting forth the number of two-way trunks to be installed and the requested installation dates within BPS' effective standard intervals or negotiated intervals, as appropriate. Big River shall populate all applicable fields in ASRs in accordance with OBF Guidelines as in effect from time to time, or use another mutually agreed upon format.
- 2.2.7 Both Parties shall monitor two-way trunk groups using service results for the applicable design blocking objective. If either Party ("Observing Party") observes blocking in excess of the applicable design objective on any two-way trunk group, the Observing Party may submit an ASR or Trunk Group Service Request ("TGSR") to the Other Party requesting that the trunk group be augmented to remedy the blocking. Upon receipt of such request, both Parties will provision additional trunks within five (5) Business Days.
- 2.2.8 The Parties will review all two-way trunk groups that reach a utilization level of seventy percent (70%), or greater, to determine whether those groups should be augmented. Big River will promptly augment all two-way trunk groups that reach a utilization level of eighty percent (80%) by submitting ASRs (or TGSRs followed by ASRs) for additional trunks sufficient to attain a utilization level of approximately seventy percent (70%), unless the Parties agree that additional trunking is not required. For each two-way trunk group with a utilization level of less than sixty percent (60%), unless the Parties agree otherwise, Big River will promptly

submit ASRs (or BPS will issue TGSRs followed by Big River's ASRs) to disconnect a sufficient number of trunks to attain a utilization level of approximately sixty percent (60%) for each respective group, unless the Parties agree that the two-way trunks should not be disconnected.

3. Trunk Group Provisioning

- 3.1 Both Parties shall use either a DS-1 or DS-3 facilities interface at the IP. When and where an STS-1 interface is available, the Parties may agree to use such an interface. Upon mutual agreement, the Parties may agree to use an optical interface (such as OC-n).
- 3.2 Unless mutually agreed to by both Parties, each Party will outpulse ten (10) digits to the other Party.
- 3.3 Each Party will use commercially reasonable efforts to monitor the traffic exchanged by the Parties over the interconnection trunk groups and to augment those groups using generally accepted trunk engineering standards so as not to exceed blocking objectives.

4. Traffic Measurement and Billing over Interconnection Trunks

- 4.1 Each Party reserves the right to audit, at its own expense, all traffic and any associated billing as specified in this Section of the Agreement, up to a maximum of two audits per calendar year to ensure that only Local Traffic and Local Internet Traffic are being routed on the Interconnection Trunks and that rates are being applied appropriately. Each Party agrees to provide the necessary Traffic data in conjunction with any such audit in a timely manner.
- 4.2 To the extent technically and economically feasible, each Party shall pass Calling Party Number (CPN) information on each call. For those Customer's whose premise equipment is unable to populate the CPN in the call detail record, each party shall populate the CPN field with the Customer's billing number, subject to the aforementioned limitations. The Parties agree that they will not populate the CPN field in the call detail record with a wholesale Customer's billing or local routing number but will utilize the final Customer's CPN or billing number.
 - 4.2.1 Where possible, actual call detail records including the CPN, will be used by the terminating Party for purposes of auditing the scope of traffic. Where a terminating Party has the capability, it will use the actual call detail records including the CPN information associated with each specific call to identify traffic delivered by the other Party as either Local Traffic, Local Internet Traffic or traffic that is not within the scope of this Agreement.
 - 4.2.2 When a terminating Party receives insufficient call detail or the CPN is missing or masked, and therefore cannot determine whether the call is or is not within the scope of this Agreement, and if the percentage of traffic delivered with CPN and having sufficient detail is greater than 90% of total calls delivered, the calls without sufficient detail or CPN will be presumed to be in the same proportion as the calls having sufficient detail and CPN.

If traffic delivered by one Party to the other Party has CPN and sufficient call detail on fewer than 90% of the calls, the terminating Party may provide written notice of a billing dispute to the other Party delivering such calls below the 90 percent threshold. Upon such notice, the Party delivering the traffic to the other Party (the "Delivering Party") shall have 30 days to investigate and correct the lack of CPN and report the date the problem was corrected to the other Party (the "Terminating Party") or provide evidence indicating the nature of calls that have insufficient call detail or lack a CPN. If the problem cannot be repaired within 30 days of the written notice to bring the delivered traffic without CPN to fewer than 10% of total calls, the Terminating Party will bill all traffic without CPN based on its intrastate access tariff until such time as the traffic without CPN is fewer than 10% of total traffic.

5. Local Traffic and Local Internet Traffic

- 5.1 The specific compensation terms and conditions set forth in this Section of the Agreement are applicable to Local Traffic, as defined in Attachment A ("Glossary"), together with all other terms and conditions set forth in this Agreement. The specific compensation terms and conditions set forth in this Section are not applicable to any other kind of traffic or for traffic that originates or terminates in areas outside the scope of Local Traffic as defined in this Agreement.
- 5.2 The Parties agree that the nature of the Local Traffic to be exchanged between the Parties and all other mutual provisions and relative obligations of the Parties pursuant to this Agreement represent good and valuable consideration, the sufficiency of which between the Parties is acknowledged, and that the relative obligations and consideration are sufficiently in balance between the Parties such that, within the scope of this Agreement, neither Party has any obligation to provide any monetary compensation to the other Party for the other Party's origination or termination of Local Traffic (i.e., Bill and Keep) so long as the Local Traffic between the Parties is approximately balanced, which for purposes of this Agreement shall mean that the split of Local Traffic is within the range of 60%/40% in either direction.

If the split of Local Traffic between the Parties is outside the range of 60%/40% for three consecutive months, the Parties agree to then, henceforth, reciprocally and symmetrically compensate one another for Local Traffic originated on their respective network and terminated to an end-user on the other Party's network at a rate of \$.0093 per minute; provided, however, that the Parties shall not be required to commence reciprocally and symmetrically compensating one another unless one Party notifies the other, in writing, of that Party's desire to commence such a compensation arrangement. Each Party shall thereafter record and issue bills for Local Traffic using call detail information measured from the local interconnecting trunks. If, subsequently, the split of Local Traffic between the Parties falls within the range of 60%/40% for three consecutive months, the Parties shall return to Bill and Keep retroactive to the first such month following the third consecutive month that the split of Local Traffic was within the range of 60%/40%; provided, however, that the Parties shall not be required to return to Bill and Keep unless one Party notifies the other, in writing, of that Party's desire

to return to the Bill and Keep compensation arrangement.

During any period(s) when reciprocal and symmetrical compensation is in effect, BPS will submit a bill that nets amounts payable by Big River to BPS against amounts due from BPS to Big River.

The compensation terms and conditions set forth in this section are specifically related to and dependent on all of the provisions of Section 5.1 and any other terms and conditions of this Agreement.

5.3 Traffic Not Subject to Terms and Conditions for Local Traffic

5.3.1 The terms and conditions set forth in this Agreement for Local Traffic do not apply to the following: (1) any Internet Traffic; (2) interstate or intrastate Exchange Access or exchange services for Exchange Access; (3) intraLATA Toll Traffic or interLATA Toll Traffic, including, but not limited to, calls originated on a 1+ presubscription basis, or on a casual dialed (10XXX/101XXXX) basis; (4) Switched Exchange Access Service traffic; or (5) Optional Extended Local Calling Area Traffic. The terms and conditions set forth in this Agreement for Local Traffic do not apply to traffic either originated from or terminated to a Party's Customer where the Customer location is physically located outside of the geographic area that has been identified as the Rate Center Area associated with a particular NPA-NXX, except in the case of Foreign Exchange ("FX") service provided in accordance with approved tariffs.

5.4 Treatment of Local Internet Traffic.

5.4.1 The Parties agree to transport and switch Local Internet Traffic in the manner described below in this section subject to amendment upon written agreement of the Parties.

5.4.2 The Parties acknowledge that under current network and service arrangements, some Internet Traffic may be switched and transported as if Local Internet Traffic is Local Traffic. The switching and transport of Local Internet Traffic over the Interconnection Trunk facilities by either Party, however, will not be deemed or construed by either Party as either agreement or acknowledgment by the Parties that this arrangement is proper or required. Notwithstanding any other provision of this Agreement, the Parties agree that the mutual provisions and relative obligations of the Parties, including but not limited to, the mutual exchange of Local Internet Traffic, pursuant to this Agreement, represent good and valuable consideration, the sufficiency of which between the Parties is acknowledged and as a result of the Agreement set forth above, neither Party will owe a net due amount to the other Party for terminating Local Internet Traffic including, but not limited to, compensation for switching, transport or termination of Local Internet Traffic.

5.4.3 A call placed on a non-local basis (e.g., a toll call or 8yy call) to an ISP

shall not be treated as Local Internet Traffic for compensation purposes. The Parties agree that, to the extent such "non-Local" ISP calls are placed, that the rates, terms and conditions for IntraLATA and/or InterLATA calling shall apply, including but not limited to rating and routing according to the Party's applicable tariffs and the application of intrastate and/or interstate Switched Exchange Access Service tariffs, as appropriate.

- 5.4.4 Where the public switched network, local exchange facilities and/or services of either Party are used for the origination or termination of VOIP Traffic calls, the Parties agree to apply the following terms and conditions: VOIP Traffic calls will be originated and terminated in the same manner as each Party does for non-VOIP, circuit-switched Traffic. VOIP Traffic shall be subject to the same compensation terms and conditions as applies for circuit switched calls. Consequently, VOIP Traffic that both originates and terminates within a local calling area as defined for Local Traffic or Local Internet Traffic pursuant to this Agreement will also be treated as Local Traffic or Local Internet Traffic pursuant to this Agreement. All other VOIP Traffic will be treated as either intrastate or interstate interexchange traffic subject to the same terms and conditions as any other circuit-switched interexchange traffic, including the application of originating and terminating Switched Exchange Access Service charges.

6. Reserved for Future Use

7. Intermediary Services

Neither Party shall provide an intermediary or transit traffic function for the other Party's connection of its End Users to the End Users of a third party telecommunications carrier without the consent and agreement of all Parties. This Agreement does not obligate either Party to provide or utilize any intermediary or transit traffic function of the other Party.

8. Number Resources, Rate Center Areas and Routing Points

- 8.1 Nothing in this Agreement shall be construed to limit or otherwise adversely affect in any manner either Party's right to employ or to request and be assigned any Central Office Codes ("NXX") pursuant to the Central Office Code Assignment Guidelines and any relevant FCC or Commission orders, as may be amended from time to time, or to establish, by Tariff or otherwise, Rate Center Areas and Routing Points corresponding to such NXX codes.
- 8.2 During the term of this Agreement, Big River shall adopt the Rate Center Area and Rate Center Points that the Commission has approved for BPS. Big River shall assign whole NPA-NXX codes to each Rate Center Area or where, applicable, thousand number blocks within a NXX Code assigned to that Rate Center unless otherwise ordered by the FCC, the Commission or another governmental entity of appropriate jurisdiction, or the telecommunications industry adopts alternative methods of utilizing NXXs.
- 8.3 It shall be the responsibility of each Party to program and update its own switches

and network systems. Except as expressly set forth in this Agreement, neither Party shall impose any fees or charges whatsoever on the other Party for such activities.

9. Installation, Maintenance, Testing and Repair.

9.1 Unless otherwise agreed in writing by the Parties, Interconnection provided by a Party shall be equal in quality to that provided by such Party to itself, any subsidiary, affiliates or third party. If either Party is unable to fulfill its obligations under this Section, it shall notify the other Party of its inability to do so and will negotiate alternative intervals in good faith. The Parties agree that the standards to be used by a Party for isolating and clearing any disconnections and/or other outages or troubles shall be at parity with standards used by such Party with respect to itself, any subsidiary, affiliate or third party.

9.2 A maintenance service charge applies whenever either Party requests the dispatch of the other Party's personnel for the purpose of performing maintenance activity on the interconnection trunks, and any of the following conditions exist: (a) No trouble is found in the interconnection trunks; (b) The trouble condition results from equipment, facilities or systems not provided by the Party whose personnel were dispatched; or (c) Trouble clearance did not otherwise require a dispatch, and upon dispatch requested for repair verification, the interconnection trunk does not exceed maintenance limits.

9.2.1 If a maintenance service charge has been applied and trouble is subsequently found in the facilities of the Party whose personnel were dispatched, the charge will be canceled.

9.2.2 Billing for maintenance service by either Party is based on each half-hour or fraction thereof expended to perform the work requested. The time worked is categorized and billed at one of the following three rates: (1) basic time; (2) overtime; or (3) premium time as follows per half hour or fraction thereof:

Basic Time per technician normally scheduled working hours	\$23.00
Overtime per technician outside of normally scheduled working Hours on a scheduled work day	\$34.50
Premium Time per technician outside of scheduled work day	\$46.00

A call out of a Party's employee at a time not within the employee's scheduled work period is subject to a minimum charge of two (2) hours.

10. Number Portability - Section 251(B)(2)

10.1 Scope

The Parties shall provide local number portability (LNP) in accordance with rules and regulations as prescribed from time to time by the FCC and the Commission.

10.2 Procedures for Providing LNP ("Local Number Portability")

- 10.2.1 The Parties will follow the LNP provisioning process recommended by the North American Numbering Council (NANC) and adopted by the FCC. In addition, the Parties agree to follow the LNP ordering procedures established at the OBF. The Parties shall provide LNP on a reciprocal basis. LNP shall only be provided within the geographic Rate Center Area associated with the ported number and shall not be provided across Rate Center Area boundaries. LNP shall not be provided for the purpose of avoiding toll or long distance charges.
- 10.2.2 A Customer of one Party ("Party A") elects to become a Customer of the other Party ("Party B"). The Customer elects to utilize the original telephone number(s) corresponding to the Telephone Exchange Service(s) it previously received from Party A, in conjunction with the Telephone Exchange Service(s) it will now receive from Party B. After Party B has received authorization from the Customer in accordance with Applicable Law and sends an LSR to Party A, Parties A and B will work together to port the Customer's telephone number(s) from Party A's network to Party B's network. Party B shall be charged and shall pay to Party A either the Basic Initial LSR Service Order Charge or the Basic Subsequent Service Order Charge as set forth in Appendix A. When a ported telephone number becomes vacant, e.g., the telephone number is no longer in service by the original end user, the ported telephone number will be released back to the Local Service Provider owning the switch with which the NXX block associated with the ported number was assigned originally by the North American Numbering Plan Administrator.
- 10.2.3 When a telephone number is ported out of Party A's network, Party A will remove any non-proprietary line based calling card(s) associated with the ported number(s) from its Line Information Database (LIDB). Reactivation of the line-based calling card in another LIDB, if desired, is the responsibility of Party B or Party B's Customer.
- 10.2.4 At a Party's option, when a Customer of Party A ports its telephone numbers to Party B and the Customer has previously secured a reservation of line numbers from Party A for possible activation at a future point, these reserved but inactive numbers may be ported along with the active numbers to be ported; provided the numbers have been reserved for the Customer and all payments for such reservation have been made by the Customer. Party B may request that Party A port all reserved numbers assigned to the Customer or that Party A port only those numbers listed by Party B. As long as Party B maintains reserved but inactive numbers ported for the Customer, Party A shall not reassign those numbers. Party B shall not reassign the reserved numbers to another Customer.
- 10.2.5 When a Customer of Party A ports its telephone numbers to Party B, in the process of porting the Customer's telephone numbers, Party A shall implement the ten-digit trigger feature where it is available. When Party A

receives the porting request, the unconditional trigger shall be applied to the Customer's line before the due date of the porting activity. When the ten-digit unconditional trigger is not available, Party A and Party B must coordinate the disconnect activity.

- 10.2.6 The Parties shall furnish each other with the Jurisdiction Information Parameter (JIP) in the Initial Address Message (IAM), containing a Local Exchange Routing Guide (LERG)-assigned NPA-NXX (6 digits) identifying the originating switch on calls originating from LNP capable switches.
- 10.2.7 Where LNP is commercially available, the NXXs in the office shall be defined as portable, except as noted below, and translations will be changed in the Parties' switches to open those NXXs for database queries in all applicable LNP capable offices within the LATA of the given switch(es).
- 10.2.8 All NXXs assigned to LNP capable switches are to be designated as portable unless a NXX(s) has otherwise been designated as non-portable. Non-portable NXXs include NXX codes assigned to paging services; codes assigned for internal testing and official use and any other NXX codes required to be designated as non-portable by the rules and regulations of the FCC. NXX codes assigned to mass calling on a choked network may not be ported using LNP technology but are portable using methods established by the NANC and adopted by the FCC. On a prospective basis, newly assigned codes in switches capable of porting shall become commercially available for porting with the effective date in the network.

10.3 Verification Procedures

- 10.3.1 Neither Party shall submit an LSR for LNP unless the party submitting the LSR has first obtained express authorization from the Customer. For purposes of this Agreement, "express authorization" means an express, affirmative act by the Customer clearly agreeing to port that Customer's number from one Party to the other. A Customer can give express authorization in any of the following forms:
 - (a) a written authorization from the Customer;
 - (b) an oral authorization verified and recorded by an independent third party;
 - (c) a recorded electronic authorization; or
 - (d) some other form of recorded authorization.
- 10.3.2 The Party submitting an LSR for LNP need not provide the other Party a copy of the express authorization in order for the LSR to be processed. However, should a question concerning the ported telephone number arise, the Party requesting the LSR shall immediately provide the other Party with a copy of the express authorization and shall also fully

cooperate in efforts to verify that express authority existed to port the telephone number. If it is determined that the Party requesting the LSR did not have the express authority required by this Section 10.3 or otherwise failed to comply with the requirements of Applicable Law, then the Party requesting the LSR shall be solely responsible for all costs associated with the unauthorized porting. That Party also will indemnify and hold harmless the other Party from any liability, including reasonable attorneys' fees, that may result from the unauthorized porting.

ATTACHMENT D

PRICING

1. General

- 1.1 As used in this Attachment, the term "Charges" means the rates, fees, charges and prices for a Service.
- 1.2 The Charges for a Service shall be the charges for Services as detailed in this Attachment or Appendix A, as applicable.
- 1.3 In the absence of Charges for a Service established pursuant to this Agreement, the Charges for the Service shall be the Providing Party's FCC or Commission approved Charges or as mutually agreed to by the Parties in writing.

2. Big River Prices

Notwithstanding any other provision of this Agreement, the Charges that Big River bills BPS for Big River's Services shall not exceed the Charges for BPS' comparable Services.

APPENDIX A
BPS TELEPHONE COMPANY and BIG RIVER TELEPHONE COMPANY, LLC

A. Designation of the IP(s):

For purposes of this Agreement, the Indirect Interconnection Points between Big River and BPS will be deemed to be at the same location where BPS meets AT&T, which is:

- i) the Parma Central Office, and
- ii) the Steele exchange boundary (the "meet points").

Big River will be responsible for ordering special access facilities from AT&T from Big River's network to the meet points. Big River will be responsible for the payment of any charges assessed by AT&T for the facilities provided by AT&T up to the meet points between AT&T and BPS. BPS will be responsible for providing the facilities from its Central Offices to the meet points with AT&T. Pursuant to Section 2.1.1.D of Attachment C, Big River will not be responsible for the payment of any charges to BPS for special access facilities provided by BPS from its Central Office to the meet points. The Parties agree that BPS will be providing its portion of the special access facilities in accordance with its intrastate access tariff.

For purposes of this Agreement the following two Direct Interconnection Points between Big River and BPS will be deemed at the following locations:

- i) The Bernie Central office of BPS, located at 103 West Fordyce, Bernie, MO. This point of interconnection will serve both the Bernie and Parma exchanges, and
- ii) The Steele Central Office of BPS, located in Steele, MO.

B. Reciprocal Compensation

- 1.1 Each Party shall bill its end-users for Local Traffic and Local Internet Traffic and will be entitled to retain all revenues from such traffic without payment of further compensation to the other Party so long as the Local Traffic between the Parties is approximately balanced, which for purposes of this Agreement shall mean that the split of Local Traffic is within the range of 60%/40% in either direction (i.e., Bill and Keep).

If the split of Local Traffic between the Parties is outside the range of 60%/40% for three consecutive months, the Parties agree to then, henceforth, reciprocally and symmetrically compensate one another for Local Traffic originated on their respective network and terminated to an end-user on the other Party's network at a rate of \$.0093 per minute; provided, however, that the Parties shall not be required to commence reciprocally and symmetrically compensating one another unless one Party notifies the other, in writing, of that Party's desire to commence such a compensation arrangement. Each Party shall thereafter record and issue bills for Local Traffic using call detail information measured from the local

interconnecting trunks. If, subsequently, the split of Local Traffic between the Parties falls within the range of 60%/40% for three consecutive months, the Parties shall return to Bill and Keep retroactive to the first such month following the third consecutive month that the split of Local Traffic was within the range of 60%/40%; provided, however, that the Parties shall not be required to return to Bill and Keep unless one Party notifies the other, in writing, of that Party's desire to return to the Bill and Keep compensation arrangement.

During any period(s) when reciprocal and symmetrical compensation is in effect, BPS will submit a bill that nets amounts payable by Big River to BPS against amounts due from BPS to Big River.

C. LSR Ordering Charges for LNP Activity

- Basic Initial LNP Service Order Charge = \$24.00 per each initial request by one Party to the other Party per LNP request per Customer -- To be billed to and paid by the requesting Party.
- Basic Subsequent LNP Service Order Charge = \$12.00 per each time the requesting Party submits a revised request per LNP request per Customer after a Firm Order Confirmation (FOC) has been issued, but will not be assessed on any requests for the postponement of a scheduled port that are made at any time before 2:00 pm on the day prior to the scheduled port - To be billed to and paid by the requesting Party.

In accordance with Section 6.1 of the Principal Document, both Parties agree that in the event that either, the FCC or the Missouri PSC issues a final and unstayed order that establishes a nonrecurring charge for porting a number or establishes or modifies a cost methodology for order activity related to porting a number that is inconsistent with the charges herein, the terms related to these LSR Ordering Charges for LNP Activity may be renegotiated upon request by either Party and amended in writing to this Agreement.

D. DIRECTORY LISTINGS & BOOKS

1. Directory Listing Report
 - Annual directory validation listing report of \$25.00 to be billed to and paid by Big River to BPS.
 - Subsequent Requests of \$50.00 to be billed to and paid by Big River to BPS
2. Big River will not be charged for its subscriber's listings for each primary listing (i.e., published) in the White Page Directory and/or in the Yellow Page Directory. For other Directory Listing Services, i.e. foreign listings, additional listings, enhanced listings, etc., Big River will be charged a monthly amount equal to BPS' retail tariff for such services.

3. Books & delivery (annual home area directories only) --- No charge will apply for normal number of books delivered to Customers; additional delivery or bulk delivery per separate arrangement between BPS and Big River. Big River shall be responsible for any additional charges related to any requests for distribution of directories that are not included in BPS' Directory Publishing Agreement.

APPENDIX B
NETWORK INTERCONNECTION DIAGRAMS

Facilities Points of Interconnection

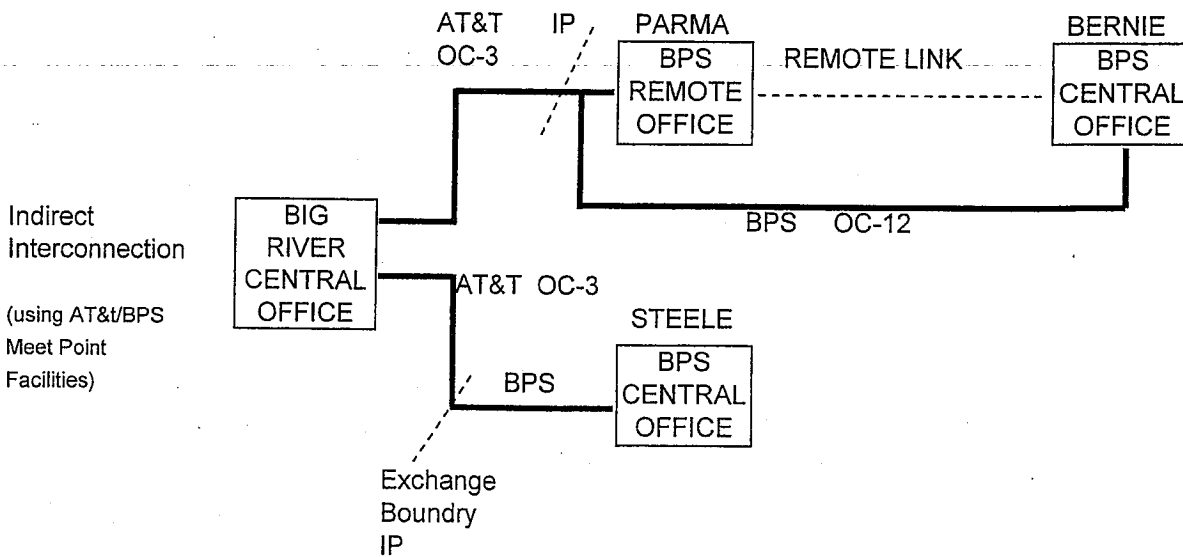
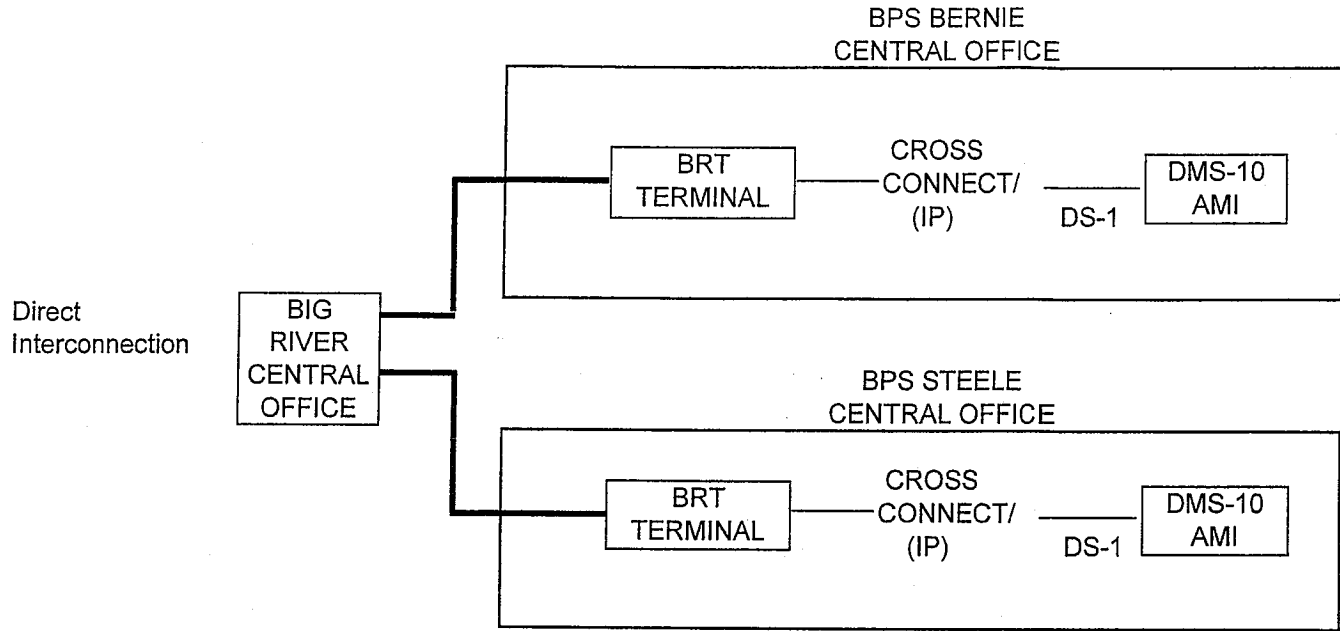

STATE OF MISSOURI)
) ss
COUNTY OF STODDARD)

AFFIDAVIT OF LISA WINBERRY

The undersigned Lisa Winberry, being first duly sworn, on her oath states that:

1. she is the Manager of BPS Telephone Company ("BPS") and has personal knowledge of the interconnection agreement between BPS and Big River Telephone Company ("Big River") that was voluntarily entered into between the parties on or about January 11, 2008 ("the Agreement");

2. the Agreement is the result of negotiation and compromise between the parties, and if the Agreement is approved without change there are no outstanding issues between the parties that the Missouri Public Service Commission needs to resolve through mediation or arbitration;

3. approval of the Agreement is consistent with the public interest, convenience, and necessity because it will allow the exchange of traffic between BPS and Big River; and

4. the Agreement does not discriminate against any telecommunications carrier and, as may be required by law, BPS will make the terms of the Agreement available to any other carrier.

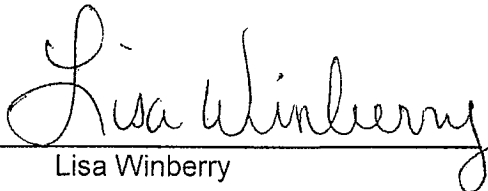

Lisa Winberry

Subscribed and sworn to before me, the undersigned Notary Public in and for the county and state aforesaid, on the 22nd day of January, 2008.

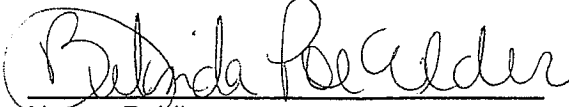

Notary Public

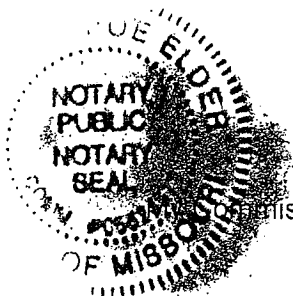

Commission expires: _____

