

Steve J  
Seidl/PAWC  
IAWWSC

05/22/2006

03:58 PM

To Steve Tambini/NAWC/AWWSC@AWW, William Varley/LIWC/AWWSC@AWW, William C  
Kelvington/PAWC/AWWSC@AWW, Keith L. Carler/KAWC/AWWSC@AWW, Douglas R  
Amos/SERVCO/AWWSC@AWW, John Watson/TAWC/AWWSC@AWW, William Walsh/VAWC/AWWSC@AWW,  
Frank Kartmann/MAWC/AWWSC@AWW, Cheryl D Norton/BELLAB/AWWSC@AWW, Alan J  
DeBoy/NAWC/AWWSC@AWW, David K Little/OAWC/AWWSC@AWW, Brock Earnhardt/IAWC/AWWSC@AWW,



Troy Day/AZAWC/AWWSC@AWW, Tom Bunosky/CAWC/AWWSC@AWW  
cc Robert G MacLean/ADMIN/CORP/AWWSC@AWW, Deborah P Lippert/PAWC/AWWSC@AWW, Jarold Jackson/KAWC/AWWSC@AWW, Sean Graves/WVAWC/AWWSC@AWW, Romie Mundy/WVAWC/AWWSC@AWW, Gregg VanPelt/WVAWC/AWWSC@AWW, Monty Bishop/TAWC/AWWSC@AWW, Albert Walukona/VAWC/AWWSC@AWW, Douglas J Woodhouse/VAWC/AWWSC@AWW, Robert F McIntyre/MDAWC/AWWSC@AWW, Greg Weeks/MOAWC/AWWSC@AWW, Fred L Ruckman/LAWC/AWWSC@AWW, Stacy Sagar/INAWC/AWWSC@AWW, Fred Cole/AZAWC/AWWSC@AWW, Jeffrey W Slucky/AZAWC/AWWSC@AWW, Todd H Brown/CAWC/AWWSC@AWW, Tom V Glover/CAWC/AWWSC@AWW, Ben J Claase/LWVC/AWWSC@AWW, Michael Balvo/PAWC/AWWSC@AWW, Steven P Dlubala/MAW/AWWSC@AWW, Kathy Wright/MAWC/AWWSC@AWW, Lee A Mansfield/HAWC/AWWSC@AWW, Michael W Merka/SWU/AWWSC@AWW, Chaille Jonas/IAWC/AWWSC@AWW, Randy A Moore/CAWC/AWWSC@AWW, Stephen F Schmitt/ADMIN/CORP/AWWSC@AWW, Michael H Gray/MOAWC/AWWSC@AWW, David Gelona/INAWC/AWWSC@AWW, Shawn A Scanlon/PAWC/AWWSC@AWW, Mitchell W Stauffer/INAWC/AWWSC@AWW, Wynn E Wright/INAWC/AWWSC@AWW, Samuel P Frazzini/CAWC/AWWSC@AWW, Alfred Yanez/CAWC/AWWSC@AWW, Craig E Anthony/CAWC/AWWSC@AWW, Andrew Clarkson/ADMIN/CORP/AWWSC@AWW, Benjamin Lewis/CAWC/AWWSC@AWW, Douglas R Mitchem/LAWC/AWWSC@AWW

Su RESPONSE NEEDED - Valve Practice Implementation and Training  
tje  
el

I am pleased to share with you an implementation plan for the Valve Operation, Inspection and Maintenance Practice (see link below) that was approved last November. The BQP team has been working with the Valve Practice development team and the AW Learning Council to develop a complete package of classroom and hands-on training materials and guidelines to implement training in your state operations. The program has been very successfully piloted in Sacramento, CA.

What we will need from you is your sponsorship of this implementation and training within the operations in your state. To get started, we need you to identify your State Representative who will lead the implementation and training. They will, in turn, identify and work with a trainer at each operating center. I suggest that our five smallest states (HI, NM, TX, MI, MD) coordinate with their larger "partner" state (CA, AZ, MO, IN, VA respectively) since I think those larger state representatives can easily cover the smaller states too. The BQP/Learning Council partnership team will prepare and support those State Representatives and will reach out to them as soon as they are identified. Please refer to the attached word document which outlines the responsibilities of the State Representative (page 1) and the Operating Center Trainers (page 2).

We already have State Representatives identified for CA (Al Yanez), NJ (Dave Gelona), and IN (Mitch Stauffer and Wynn Wright) and training is moving forward in these states. For all other states, we suggest you consider one of the members of the Valve Practice Development team or other 2007 Distribution Maintenance workshop participants, who are listed in the attached excel file. If you did not have anyone participate or they can not be available, please consider an experienced Field Operations manager, supervisor or hourly employee who has a passion for operational excellence and an interest in delivering training.

[attachment "Valve State Rep & Trainer guidelines.doc" deleted by Douglas R Amos/SERVCO/AWWSC]  
[attachment "Workshop Attendees.R1.xls" deleted by Douglas R Amos/SERVCO/AWWSC]

[http://intranet.amwater.net/governance/docs/ops\\_svd\\_net\\_pr\\_03\\_valveo&m\\_2007\\_11\\_21.pdf](http://intranet.amwater.net/governance/docs/ops_svd_net_pr_03_valveo&m_2007_11_21.pdf)

Your support and leadership is critical to the success of this program, which we believe will improve our operations companywide. Please let me know if you have any questions. I look forward to your reply and identification of your State Representative.

Steven J. Seidl  
American Water - Operational Services  
Director, Best Operating Practices  
800 West Hershey Park Dr  
Hershey, PA 17033  
(717) 520-4607 (office)  
(717) 520-4636 (fax)  
(717) 574-2167 (cell)

©AMERICAN WATER 2007  
Company Confidential



Practice Name: **Valve Operation, Inspection, and Maintenance Practice**  
Functional Area: **Operations - Service Delivery - Field Operations**  
Practice Number: **ops\_svd\_net\_pr\_03\_valvoo&m\_2007\_11\_21.doc**

**PURPOSE**

The objective of this practice (hereinafter the "Practice") is to ensure that American Water Works Company, Inc. and its regulated subsidiaries, including, for purposes of this practice, American Water Works Service Company, Inc. (together "American Water" or the "Company") develop and utilize a consistent program to effectively inspect and maintain valves within its distribution systems in order to ensure the operational integrity of these assets and to optimize the utilization of personnel resources. Effective valve maintenance is important to local operations as a pro-active program may increase valve reliability, reduce valve failure, and extend valve life. The failure of valves as a result of insufficient maintenance may result in extensive damage to infrastructure and/or property loss, extended service interruptions to our customers and can lead to costly repairs or replacement activities.

An effective valve maintenance program may also provide the following benefits to the Company:

- Monitoring of the system;
- Assisting future planning purposes for replacement;
- Providing a faster response to emergency events;
- Minimizing risk (notably property loss and damages);
- Reducing the cost of repairs/installations;
- Reducing the impact to customers of service interruptions;
- Maximizing the Company's credibility to external parties including regulators.

This Practice is currently limited to the following:

1. Valve Inspection Procedure;
2. Valve Inspection Data List/Valve Attribute Data List;
3. Frequency Table for Valve Inspection and Locating.

Future amendments to be considered may include:

1. Guidelines and procedures for repair and replacement;
2. Equipment recommendations for valve operating.

**APPLICABILITY**

The Practice supports the Company's *Strategy: Asset Maintenance Management*. This Practice also will support the implementation of the Computerized Maintenance Management System (CMMS).

**PRACTICE**

One of the first questions a local operating unit may confront is how to start a valve program where a program does not exist. This Practice recognizes that in the absence of a pre-existing program, the implementation of such a program may be daunting. Moreover, where valves



have not been inspected and operated recently or regularly, there exists the increased possibility that valves may be damaged when operated. It is suggested that the following criteria be employed when the local operating unit is deciding where to begin a valve program:

Criteria For Where To Start A Valve Operating Program Where No Pre-Existing Program Exists:

The primary step to employ is to refer to the distribution map grid system to begin systematically working through valves by grid using no other criteria other than the map.

If data exists however, a local operating unit may wish to sequence the grids to focus on any of the following areas first:

- Where there have been a high frequency of main breaks;
- Valves in the oldest part of system;
- Beginning at the source of supply and moving to the extremities of the system;
- By valve size;
- Where critical customers are located;
- Customer density (when starting a program, the local operating unit may wish to inspect and operate valves in low density areas first because fewer customers would be put out of service as a result of breaking a valve);
- Where valve density and redundancy exist;
- Hydrant auxiliary valves where hydrants are thought to be vulnerable to failure (high traffic areas, hydrants used by municipality on regular basis, i.e., street sweepers, fire trucks).
- Valves in areas of proposed upcoming pipe replacement and rehabilitation

At the same time, it is recognized that many local operating units have pre-existing programs and employ various methods of inspecting and operating valves within their respective areas. Accordingly, the following guidance is offered to these areas as opportunities to improve a pre-existing program:

How to Improve a Pre-Existing Valve Program:

1. Identify individual valve criticality in accordance with the *Practice: Reliability Centered Maintenance* and apply applicable maintenance frequencies that are indicated in the table in Appendix A;
2. Update/expand database attributes;
3. Examine areas with substantial network activity;
4. Coordinate program with external programs, e.g. repaving projects; external construction activity;
5. Coordinate program with other internal programs, e.g. hydrant inspection and flushing, internal construction activity;

**NOTE** – In performing any valve work, the local operating unit must consider the impact on water quality. For example, there may be an impact in the system where, during the operating of a blow-off valve, the flow of water stirs up sediment in the main. Water quality may not be affected where the operating of a valve does not result in flow velocities sufficient enough to stir up sediment.



### Valve Inspection and Operation Procedure

#### Primary tasks for all Valves:

1. Locate valve (verify measurements, GPS coordinates, landmarks);
2. Set-up traffic control and observe applicable safety procedures;
3. If data exists, review valve size, valve type (butterfly, gate, etc.), the number of turns required to fully open or fully close valve, function of valve (transmission, hydrant auxiliary, distribution, zone separation, single source supply, etc.), direction to open, and normal position. Note -- If any information listed above is missing, then the valve should not be exercised, and report these findings to the employee's supervisor;
4. Ensure valve operation will not cause damage to the distribution system by identifying critical areas and taking extra precautions (It is important that valve inspections are coordinated with the Production Department)
  - Valves in the vicinity of pumping/booster stations, pressure zone valves, transmission valves, and single source valves are examples of critical areas;
  - Examples of extra precautions include communication and coordination with the production department and the installation of temporary pressure relief devices or bypasses.
  - Verify whether system monitors, like acoustic monitors for leak detection, are in the area and, if so how they are marked in the field.
5. Remove valve box lid. If system monitors are located in valve boxes, exercise care in removing the valve box lid because instrumentation and wiring may be attached to the lid. The system monitor is generally attached magnetically to the top of valve nut and needs to be removed prior to operation of valve. Report any damage to your supervisor and the appropriate Non-Revenue Water management staff;
6. Clean out the valve box if necessary;
7. Insert valve key onto valve nut, wheel, or tee head;
8. Except as otherwise indicated in Appendix B, operate valves through a full cycle and leave in normal operating position (note: one should consult local procedure on effective valve operating);
9. Count the number of turns and compare with manufacturer specifications;
  - A. If number of turns is not within 90% - 100% of manufacturer specifications then operate valve full cycle two to three more times. If the number of turns does not change, the operator should notify their supervisor.
  - B. If number of turns exceeds 100% of manufacturer specifications, the operator should stop valve operation and notify their supervisor that the valve may be broken.
10. Record inspection data and refer to "Inspection Data for Valves" in the Reporting Metrics Section of this Practice;
11. Update valve attribute data to make corrections or additions;
12. Restore the valve lid and clean up area if necessary; if present, restore the system monitor, checking for good contact with the valve nut. If monitor is damaged or if unsure

of whether the unit was properly restored, contact your supervisor and the Non-Revenue Water management staff.

13. Remove the traffic set-up.

Optional tasks:

At the same time, the Practice recognizes that many local operating units may wish to pursue additional steps during valve inspection. Below are optional tasks that may be pursued:

1. Open downstream hydrant during valve operation (to scour valve seat, verify positive shutdown, discover any closed valves, etc.) record lost water. If hydrant is fully inspected at time of valve operation, then record hydrant inspection data in accordance with *Practice: Hydrant Operation, Inspection and Maintenance*.
2. Sound the valve when fully closed, open the valve and resound valve.

ORGANIZATIONAL RESPONSIBILITIES

Implementation, use and tracking of defined metrics and adoption of the procedures will be the responsibility of the Field Operations supervisors and manager of the local operating unit.

REPORTING / METRICS

When inspecting and operating valves, it is recommended that the following information be captured. However, this Practice recognizes that for local operating units beginning a program, all of this information may not be practical to gather initially. Accordingly, for the local operating unit starting a valve maintenance program, it is recommended that the information appearing in bold be captured:

Attributes for Valves:

1. Valve ID
2. Legacy Valve number
3. Location
  - street name;
  - closest street address #;
  - cross street;
  - reference dimensions (distance, direction, reference point);
  - map page;
  - valve book page;
  - GPS coordinates;
  - city;
  - county;
  - municipality;
  - subdivision;
  - sketches, if available.
4. Valve size (2" -60")
5. Operating nut size
6. Valve type (gate, butterfly, ball, etc.)
7. Actuator type (manual, electric, hydraulic, pneumatic, etc.)
8. Gear type (non-rising stem, worm, spur, rising stem, etc.)
9. Operating nut type (square, tee head, wheel, etc.)
10. Pressure class (150, 200, 250, 300, 350)
11. Bypass valve present? (yes or no)



12. Seat type (resilient, bronze, CI)
13. Joint type (MJ, push-on, lead, restrained, flanged, compression)
14. Open direction (left, right)
15. Normal position (closed, open)
16. Function (distribution within grid, distribution dead-end i.e. single source, hydrant auxiliary, blow off, bypass, zone separation, transmission, service line, plant discharge, booster station discharge, pump discharge, raw water, plant)
17. Type of access (valve box, manhole, vault, pit box, atop box)
18. System monitor installed on valve? (yes or no)
19. Special valve box lid or marking? (yes or no)
20. Marking and-access notes (free form)
21. Normal system pressure
22. Number of turns by design (i.e. from full open to full closed)
23. Top of main depth
24. Operating nut depth
25. Criticality (high, medium, low)
26. Criticality Identifier (drop down list)
27. Criticality Notes (free form)
28. Installation date
29. Manufacturer
30. Manufacturer model
31. Manufacture date
32. Manufacturer torque limit
33. Surface Cover Location Type (street, driveway, parking, sidewalk, other)
34. Surface Cover Material Type (concrete, asphalt, grass, landscaping, gravel/stone, soil, brick)
35. Installation Work order number
36. Status of the asset (active, retired in place, retired & scrapped, transferred, pending, etc.)
37. Inspection Route number
38. Inspection Stop/Sequence number
39. Main size (2"-60")
40. Main type (CI, DI, AC, PVC, HDPE, Steel)
41. Data collected/last updated by (person's name and company)
42. Date collected/last updated

Inspection Data for Valves:

1. Number of turns operated
2. Minimum number of turns for regulatory compliance (if applicable)
3. Torque applied (maximum value or torque curve, if available)
4. Type of operator utilized (valve key, hydraulic operator)
5. Inspection completed by (person's name and company)
6. Time spent to operate valve
7. Position valve left in (open, closed)
8. Initial direction operated (left, right)
9. Direction operated to open (left, right)
10. Position found in (open, closed, partially open)
11. Traffic control utilized
12. Date and time operated
13. Deficiencies noted
14. Any repair work performed at time of inspection
15. Additional repair work required (paved over, box broken, etc.)
16. Was valve operated per procedure? (yes or no)





- 17. Permit required for operation? (yes or no)
- 18. Permit number
- 19. Permit number expiration date
- 20. System Monitor present? (yes/no)
- 21. System Monitor adequately marked? (yes/no)

**REFERENCES**

AWWA Manual M44, Chapter 5 "Operation and Maintenance" pp. 45-50.

Strategy: Asset Maintenance Management

Practice: Hydrant Operation, Inspection and Maintenance

Practice: Reliability Centered Maintenance [under development]

**DEFINITIONS**

**Hydrant Auxiliary Valve** -- the valve used to isolate the hydrant from its connecting point to the water main. Sometimes called a lateral valve, hydrant valve, watch valve, isolation valve, or branch valve.

**REVIEW/UPDATE**

This document should be reviewed two years after issuance and every three years thereafter. The document may be revised, if necessary, based upon the results of the review.

**Practice Development Team:**

Operating Unit	Name	Title & Functional Area	Office Location (City, ST)	Role
Central Region	Frank L. Kartmann	Director, Network	St. Louis, MO	Sponsor
Business Center	Steve Seidl	Director, Best Operating Practices	Hershey, PA	Co-Lead
Business Center	Michael Gray	O&M Manager, Best Operating Practices	St. Joseph, MO	Co-Lead
Business Center	Seth Mendelsohn	O&M Manager, Best Operating Practices	Hershey, PA	Co-Lead
Tennessee	Monty Bishop	Network Superintendent	Chattanooga, TN	Member
Ohio	Sam Frazzini	Network Operations Supervisor	Franklin County, OH	Member
New Jersey	Dave Gelona	Construction Supervisor	Atlantic/Cape May, NJ	Member
Pennsylvania	Shawn Scanlon	Network Supervisor	Norristown, PA	Member
California	Al Yanez	Operations Superintendent	Newbury Park, CA	Member
Indiana	Mitchell Stauffer	Field Service Representative	Greenwood, IN	Member



**Functional Reviewers:**

Operating Unit	Name	Title & Functional Area	Office Location (City, ST)	Reviewed
Long Island	Ben Claase	Network Manager	Lynnbrook, NY	<input checked="" type="checkbox"/>
New Jersey	Robert Maclean	Director, Field Operations	Short Hills, NJ	<input checked="" type="checkbox"/>
Pennsylvania	Brian Hassinger	Network Director	Hershey, PA	<input checked="" type="checkbox"/>
Virginia/MD	Albert Walukonis	Network Superintendent	Alexandria, VA	<input checked="" type="checkbox"/>
West Virginia	Henry Perkins	Network Supervisor	Charleston, WV	<input checked="" type="checkbox"/>
Kentucky	Jarold Jackson	Network Supervisor	Lexington, KY	<input checked="" type="checkbox"/>
Tennessee	Monty Bishop	Network Superintendent	Chattanooga, TN	<input checked="" type="checkbox"/>
Ohio	David Little	General Manager, Network	Marion, OH	<input checked="" type="checkbox"/>
Indiana	Stacy Sagar	General Manager, Network	Greenwood, IN	<input checked="" type="checkbox"/>
Illinois	Fred Ruckman	General Manager, Network	Belleville, IL	<input checked="" type="checkbox"/>
Iowa	Audie Foster	Operations Supervisor	Davenport, IA	<input checked="" type="checkbox"/>
Missouri	Greg Weeks	General Manager, Network	Joplin, MO	<input checked="" type="checkbox"/>
New Mexico	Kathy Wright	Network Manager	Clovis, NM	<input checked="" type="checkbox"/>
Arizona	Troy Day	Production & Operations Director	Phoenix, AZ	<input checked="" type="checkbox"/>
California	Tom Bunosky	Network Operations Director	Chula Vista, CA	<input checked="" type="checkbox"/>
Business Center	Dave Hughes	Infrastructure Engineer, Innovation & Environmental Excellence	Voorhees, NJ	<input checked="" type="checkbox"/>

**Approvers:**

Operating Unit	Name	Title & Functional Area	Office Location (City, ST)	Approved
Central Region	Doug Mitchem	VP, Service Delivery	St. Louis, MO	<input checked="" type="checkbox"/>
Eastern Division	Wayne Mrgan	VP, Operations	Cherry Hill, NJ	<input checked="" type="checkbox"/>
Eastern Division	Brian Hassinger	Director, Network	Hershey, PA	<input checked="" type="checkbox"/>
Western Region	Ben Lewis	VP, Service Delivery	San Marino, CA	<input checked="" type="checkbox"/>
Business Center	Steve Schmitt	VP, Operational Services	Voorhees, NJ	<input checked="" type="checkbox"/>

Original Adopted: 11/21/2007  
 Revised Adopted: Not applicable  
 Date of Last Review: Not applicable



**APPENDIX A: Maintenance Tasks & Frequency Table.**

Activity/Task	Criticality	Frequency		Work Load		Specialty Tools/Skills	Comments
		Trigger	Value	Hours	#Staff		
Inspect and Operate distribution system transmission valves	High	Time	Annually	1	1-2*	Valve key/operator	Increase reliability, reduce failure, extend valve life
	Medium	Time	Every 2 yrs	1	1-2*	Valve key/operator	Same
	Low	Time	Every 6 yrs.*	1	1-2*	Valve key/operator	Same
Locate distribution system valves	High	Time	Annually	0.25	1	Map, magnetic locator, valve sketch, valve box cleaners	Ensure accessibility
	Medium	Time	Every 2 yrs	0.25	1	Map, magnetic locator, valve sketch, valve box cleaners	Ensure accessibility
	Low	Time	Every 6 yrs.*	0.25	1	Map, magnetic locator, valve sketch, valve box cleaners	Ensure accessibility
	Low	Activity (new paving, const., etc.)*	Within 1 yr. of activity	0.25	1	Map, magnetic locator, valve sketch, valve box cleaners	Ensure accessibility
Inspect and Operate distribution system valves	High	Time	Annually	0.33	1-2*	Valve key/operator	Determine accessibility and operating condition
	Medium	Time	Every 2 yrs	0.33	1-2*	Valve key/operator	Determine accessibility and operating condition
	Low	Time	Every 6 yrs.*	0.33	1-2*	Valve key/operator	Determine accessibility and operating condition
Inspect and Operate hydrant auxiliary valves	High	Time	Annually	0.33	1-2*	Valve key/operator	Determine accessibility and operating condition
	Medium	Time	Every 10 yrs.*	0.33	1-2*	Valve key/operator	Determine accessibility and operating condition
	Low	Time	Every 10 yrs.*	0.33	1-2*	Valve key/operator	Determine accessibility and operating condition



## NOTES TO APPENDIX A

This table indicates the valve maintenance activities to be performed, the frequency that the activities should be performed based on valve criticality rating, the estimated number of hours and staff members needed for the work, and the need for any specialty tools/skills.

In the column marked "Work Load," the Practice sets forth an estimate for the hours required for the maintenance work along with an appropriate number of employees to perform said work. In reviewing these guidelines and in determining the proper number of employees needed, a supervisor should consider the individual characteristics of the needed maintenance including the traffic conditions, safety of employees in the given area, and the difficulties that may be anticipated because of valve size, condition, location, and any other relevant information. The estimations are not meant as the enactment of any rule upon supervisors. Rather, the estimations are meant as a guide.

Additionally, the following criteria is offered for supervisors when applying the Frequency Table:

- The triggers for locating low criticality valves are paving reconstruction programs, new construction projects, main extensions, etc;
- The Practice attempts to provide a general framework for valve inspection even though local and/or state regulatory requirements may differ. Where such regulatory requirements differ, it is suggested that the implementation of this Practice may encourage regulatory agencies to reconsider the requirements that the law may currently impose. In other words, the regulations may be antiquated and not reflect current practice in the water industry. The successful implementation of a valve maintenance practice that differs in some manner from the regulatory requirements may support modifications in the regulatory environment.
- Frequency value for operating and locating low criticality transmission or distribution system valves (every five years) is the recommended value. Varied state regulatory compliance issues are to be considered when determining the actual frequency value to be implemented at a specific operating unit.
- Frequency value for operating hydrant auxiliary valves (every ten years) is the recommended value based on the scouring action of valve seats during hydrant inspection. Varied state regulatory compliance issues are to be considered when determining the actual frequency value to be implemented at a specific operating unit.



**Appendix B: Valves Needing Special Operational Consideration**

<b>Function:</b>	Transmission, Discharge of Plant, Booster Station, or Pump Valves	Zone Separation Valve	Single Source (dead end), "Distribution" or service line valves
<b>Normal Position:</b>	Open	Closed	Open
<b>Operation Steps:</b>	Operate a minimum 15% and a maximum of 25% of total turns if critical but a full close & full open if non-critical	Operate slowly to full open and back to full closed while monitoring and controlling pressure on low side by flowing hydrant on low pressure side of valve	Operate a minimum 15% and a maximum of 25% of turns.

## Exercising Line Valves

### What is In the Skill Package?

1. The components of gate and butterfly valves
2. Normal operation sequence of gate and butterfly valves
3. Typical valve numbering methods
4. Valve data collection procedure
5. Proper valve description
6. Proper valve exercising procedure

### Prerequisite

1. Completion of traffic control skill package

## Exercising Line Valves

Dave Gelona

### Introduction

#### Skill Package Focus

This skill package is limited to water distribution system line valves used for on and off operation. Other types of valves, such as PRVs, altitude valves, etc. are discussed in additional skill packages.

#### Common Types

The most common types of valves used for on and off or isolation operation are:

- Gate
- Butterfly
- Ball
- Plug
- Eccentric
- Globe

Of the above valves only gate and butterfly valves are typically used in water distribution system lines. Thus, these are the only valves discussed in this skill package.

#### Basic Valve Nomenclature

Almost all valves have the following components:

- **Body<sup>1</sup>** - the portion of the valve through which water passes.
- **A movable closure<sup>2</sup>** to allow flow to be controlled.
- **Valve seat** - the device that the movable closure comes in contact with in order to control flow.
- **Bonnet<sup>3</sup>** - The upper portion of the valve, commonly containing the valve stem.
- **Valve stem** - The device that is moved in order to adjust the position of the movable closure.
- **Operator<sup>4</sup>** - The device that is turned twisted or moved and is attached to the stem. Typical operators are two inch square nuts and hand wheels.
- **Inlet connections.**

<sup>1</sup> **Body** - The main portion of a valve. Commonly containing the valve seat(s) and inlet connections.

<sup>2</sup> **Movable Closure** - The portion of a valve that is moved into the flow to either control the flow or stop the flow.

<sup>3</sup> **Bonnet** - The top of a valve, housing the packing box, through which the valve stem must pass.

<sup>4</sup> **Valve Operator** - The device to which power is applied to turn a valve stem. Common valve operators are two-inch square nuts or wheels.

## Valve Descriptions

### Gate Valves

#### Types of Gate Valves

There are six different types of gate valves: the single disk, resilient seat, double disk, OS & Y, shear gate and the slide gate. OS & Y gate valves should not be placed underground and thus are not discussed in this skill package. Shear gate and slide gate valves are discussed in the raw water intake skill package.

#### Advantages of Gate Valves

All gate valves give the advantage of a full flow through the pipe or opening when the valve is open. They offer very little flow restriction resulting in low head loss.

#### Disadvantage of Gate Valves

The major disadvantage to using gate valves is they are very difficult to open under high pressure conditions. Especially when there is a significant pressure differential across the movable closure.

#### Single Disk Gate Valves

##### Use

Single disk gate valves are commonly used in small sizes, less than 4 inch, and in low pressure conditions. They are very difficult, if not impossible to open under high pressure differential conditions.

#### Single Disk Gate Valve

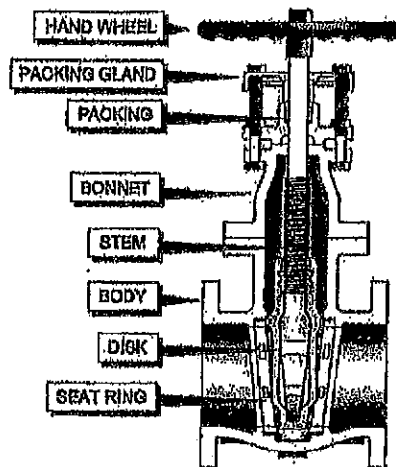

#### Components

The body of a gate valve contains the valve seat and the inlet connections. The upper portion of the valve is called the bonnet and is used to hold the movable closure when the valve is in an open position. The movable closure is a single wedge shaped device. The stem is threaded into the movable closure and when rotated, moves the closure up and down. At the top of the stem is the operator, typically a 2 inch square nut or a hand wheel. Hand wheels are popular on smaller sizes and valves used inside of buildings. The square



nut is used on valves placed underground. At the top of the bonnet is the packing plate, which holds the packing or "O" rings. On small valves, packing which is compressed by a packing nut is most common. The packing and/or "O" ring is used to control leakage around the stem.

**Operation**

To close the valve the stem is rotated and the wedge shaped closure is forced into a seat. When the stem is operated in the opposite direction the closure is raised into the bonnet.

**Rising and Non-rising Stems**

There are two stem types available: the rising and non-rising stem. With the non-rising stem the closure is threaded up and down the shaft as the stem is rotated. With the rising stem there is a threaded collar at the top of the bonnet. The stem moves up and down through this collar.

**Resilient Seat  
Relatively New**

One of the major additions to the gate valve field in recent years is the resilient seat gate valve. The resilient seat gate valve is a single disk gate with a resilient face on the disk.

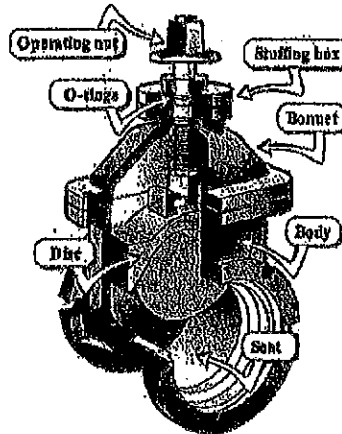

**Resilient-Seated Gate Valve**  
Courtesy of Kennedy Valve Mfg. Co.,

**Use**

The resilient seat gate valve can be used in any position where a standard gate valve is used. It offers the advantage of requiring less force than a standard gate valve to open and close.

The body is commonly made of cast iron and like other gate valves contains the valve seat and inlet connections. Notice unlike the standard gate valve there is no groove in the bottom of the valve body. Above the body is a standard cast iron bonnet. The movable closure is a single wedge shaped disk with a resilient material on one or both faces. Commonly this disk is flat on one side and wedge shaped on the other with resilient material on the sloped face.

**Operation**

A standard stem and operator are used to adjust the position of the closure. The seat is the valve body itself. Leakage around the stem is controlled by one or more "O" rings.

To close this valve the stem is rotated and the closure is moved downward wedging against the bottom and the seat of the valve body. To open the stem is rotated and the disk moves upward into the bonnet. These valves are available in rising and non-rising stem configurations.

**Double Disk Gate Valve**

One of the oldest and most common valves found in water systems is the double disk gate valve. This valve is used under normal on and off control conditions.

**Most Common**

Double disk gate valve bodies are available in PVC, brass and cast iron. In sizes larger than 3 inch cast iron is the most common. The body contains the two brass valve seats set parallel to one another. The uniqueness of this valve is the movable closure. The closure is made of two parallel disks separated by some type of wedging device. A standard brass stem is used to move the closure up and down between the body and the bonnet. Leakage around the stem is control by packing or "O" rings.

**Components**

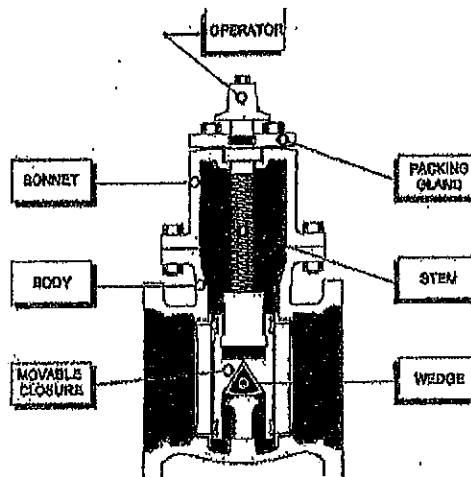

**Operation**

When the valve is in an open position the double disks are completely out of the flow path and stored in the bonnet. As the valve approaches closure a rise in the casting at the bottom of the valve is forced against some type of wedging assembly that is between the two disks. The wedge assembly pushes the two disks against their respective seats. Twisting on the stem places pressure on the top and bottom of the wedge forcing the disk against the seats. The wedge assembly design is unique for each manufacturer.

(OP-16) Exercising Line Valves

Operation  
sequence  
of double  
disk gate

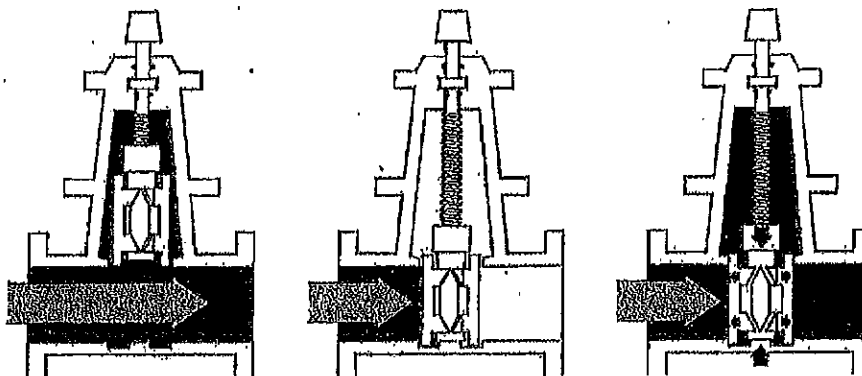

Warning

Notice that at the bottom of the body there is a channel. This channel can fill with silt. When closing the valve, if it does not stop the flow of water, back off on the stem, raise the closure and allow the flow of water under the closure to remove the silt. If after several up and down actions, the silt is not cleared then no further improvement in flow control can be made. Over tightening the stem can bend the disk and cause the leakage to increase.

OS & Y Valves

Rising or Non-rising Stem

The stem found on a gate valve may either be rising or non-rising. Non-rising stems are used in most underground installations. In non-rising stem gate valves, the movable closure moves up and down the stem as the stem rotates in the bonnet. In a rising stem gate valve the movable closure is connected to the bottom end of the stem and moves up and down with the stem.

Use of O S & Y

Rising stem gate valves are also called outside stem & yoke (OS & Y) gate valves. These are normally used as isolation valves in PRV stations, altitude valve stations, and pump stations. They should never be buried in the ground. Their major advantage is they allow easy determination of whether the valve is open or closed.

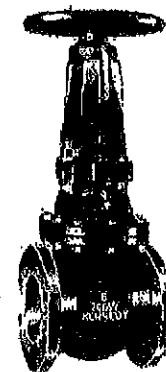

OS & Y  
Gate Valve

**Valves with By-Pass**

**Valve Position**

In most utilities gate valves installed on 12 inch and smaller lines are installed in a vertical position. On 16 inch and larger lines, gate valves are mounted horizontally. Large gate valves designed to be installed in a horizontal position are usually purchased with a three or six-inch bypass built around the valve. In addition, the movable closure is supported on a track to prevent it from dragging on the side of the valve when it is opened or closed.

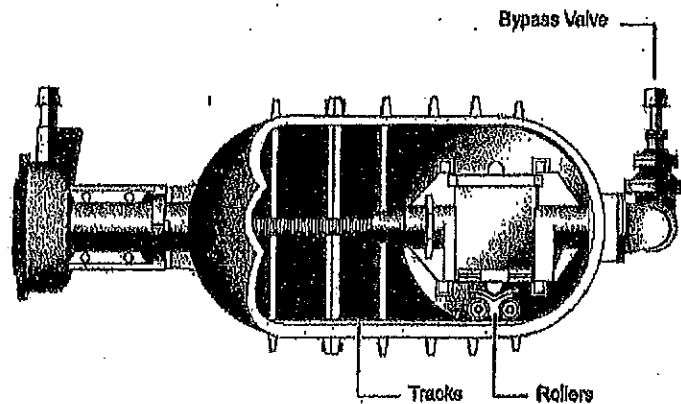

**Using a Bypass**

When the valve is shut down and the pressure differential across the valve becomes significant, the valve is very difficult to open. Under this condition, the bypass is opened first, thus equalizing the pressure on the two sides of the valve and making it much easier to open.

**Inlet Connection to Gate Valves**

**Less than 2 inch**

in gate valves less than two inch the inlet connections are basically limited to threaded, glued and soldered.

**Larger than 2 inch**

With valves larger than two inch the inlet connections available include:

- Threaded
- Hub for DCIP, PVC and AC
- Mechanical Joint
- Flanged
- Victaulic
- Dresser connection
- Spigot

Gate valves are also available in a combination of any of the two common connections. A flange by mechanical joint gate valve is a very common device for connecting a fire hydrant to a flanged tee.

**Gate Valve inlet connections**



Hub for DCIP



Mechanical Joint



Flanged



Hub for AC

**Butterfly Valves**  
Two types

There are two types of butterfly valves: those with a resilient face on the movable closure and those with a resilient face in the valve body.

Example of butterfly valve with resilient face on the movable closure

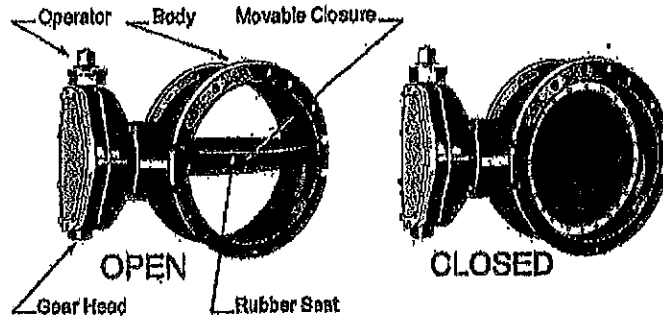

**Advantages**

The major advantage to using a butterfly valve is the ease of opening the valve under pressure. It is easier to move and requires far fewer turns than a gate valve.

**Disadvantages**

The major disadvantages to using butterfly valves is they provide a restriction of the flow path and thus higher head loss than a gate valve. Under high velocity conditions the movable closure can vibrate causing excessive water hammer.

**Uses**

Butterfly valves can be used in most conditions calling for on/off control and throttling. The exceptions are they should not be used on the lead to a fire hydrant or the suction side of an end-suction centrifugal pump.

**Components**

The butterfly valves most commonly used in water systems use a cast iron body and cast iron movable closure. There is a resilient face either on the body or closure. A gear head is used to transfer energy from the operator to the stem. A one quarter rotation of the stem moves the valve from full open to full close. Typical operators include 2 inch square nuts, hand wheels, electric motors, pneumatic and hydraulic rams.

**Operation**

The operation of the butterfly valve is relatively simple. A 1/4 turn of the shaft moves the closure from full open to full closed. When the valve is in the full open position the closure is in line with the flow. When closing, a butterfly valve may have a tendency to vibrate during the last 1/4 to 1/3 of the travel of the closure.

**Flow Control**

Other than in the first 1/4 to 1/3 of the travel of the closure the butterfly valve can be used for flow control. This gives it an advantage over the gate valve. The gate valve should never be used for flow control. The movable closure will rattle against the seat and wear a groove in the disk and the seat.

**Inlet Connections on Butterfly Valves  
Larger than 2 inch**

With valves larger than two inch the inlet connections available include:

- Threaded
- Hub for DOP, PVC and AC
- Mechanical Joint
- Flanged
- Victaulic
- Wafer - a special joint that allows the valve to be placed between two flanges
- Spigot

Butterfly valves are also available in a combination of any of the two common connections.

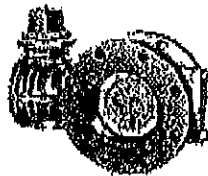

Flanged

Courtesy of M & H Valve Co.



Mechanical Joint

Courtesy of M & H Valve Co.



Wafer

Courtesy of M & H Valve Co.

**Proper Valve Description  
Description Sequence**

In order to properly describe valves, the following sequence should be used:

1. **Size**  
Start by giving the valve size.
2. **Valve Type**  
Next give the valve type - either gate or butterfly.
3. **Body Material**  
The body material is next. Valves are made from plastic, bronze, gray cast iron, and ductile cast iron.
4. **Connection Type**  
Now identify the type of connections. Valves can be purchased with a wide variety of inlet connections. The most common connections are flange, hub, and mechanical joint<sup>1</sup>. Valves may also be purchased with a combination of connections, such as hub on one side and mechanical joint on the other. In addition to the type of connection, the piping material must also be identified. The two most common hub sizes are IPS (iron pipe size used by PVC pressure pipe) and OIP (cast iron pipe size used by DIP and PVC class pipe). Hub and mechanical joint connections are the most common.

<sup>1</sup>Mechanical Joint - A joint used on cast iron valves, fittings, fire hydrants, and cast iron pipe. The joint consists of rubber gasket and follower rings that are held to a flange by a row of bolts. The gasket is compressed between the follower ring and the flange seat.

**5. Operator Type**

The description of the operator needs to indicate type and shape. Common operators are the two-inch square nut, hand wheels, and electric. Two-inch square operating nuts are the most common for all underground installations.

**6. Pressure**

Operating pressure is next. The pressure rating is an important part of the description. Valves are manufactured for pressures from 125 psi to 3000 psi. The most common pressure ratings used in water distribution systems are 200 or 250 psi.

**7. Special Considerations**

One of the most important areas of the description is the special considerations section. This section covers the number of discs and the type of valve seals. It describes if the stem is rising or non-rising and if the type of packing is conventional or "O" rings. It also covers the direction of rotation of the shaft to open the valve and gives special information on valves that are to be mounted horizontally rather than vertically.

**Example**

In summary, the adjacent valve would be described as a six-inch gate valve with cast iron body and mechanical joints, two-inch square operator nut, 200 psi with double disc and non-rising stem. Most utilities standardize on valve types, pressure ratings, operating nut size, and special conditions. Therefore, this valve could be described as a six-inch MJ X MJ gate valve.





**Valve Boxes**  
Description

Valve boxes should be installed with each valve. A valve box may refer to a vault or tubular structure that allows direct access to the valve operating nut. They may be made from cast iron, steel, PVC, concrete or other materials. It is desirable to use valve boxes with lids made of cast iron or steel to make it easier to find the valve box with a line finder.

**Parallel to Stem**

They must installed parallel to the alignment of the valve stem. The operating nut should be centered in the box. The box should not touch the valve and should be at least two inches above the main.

**Example**

The example below shows a three pieces cast iron valve box installed in a concrete street. The area around the valve box is asphalt. The utility from which this drawing came uses this process to make it easier to access the valve box. Asphalt is easier to remove by a field crew than concrete.

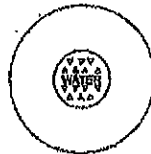

Plan View of Valve Box

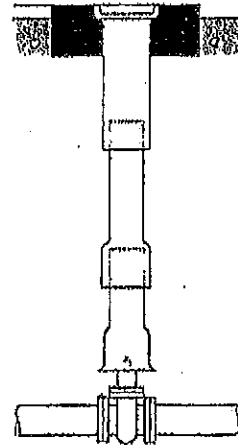

Profile View of Valve Box

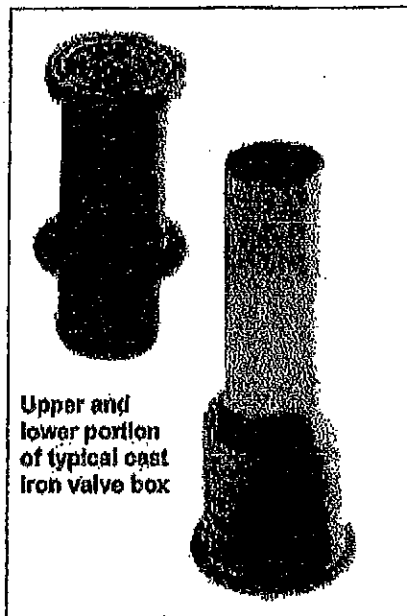

Upper and lower portion of typical cast iron valve box

## (OP-16) Exercising Line Valves

Mike Gray

### Two Divisions of Work

There are two major divisions of work required for implementing a valve exercising program. The first is the office work and the second is the field work

### Office Procedure

#### Maps

#### Valves Data

#### Criteria For Where To Start A Valve Operating Program Where No Pre-Existing Program Exists:

The primary step to employ is to refer to the distribution map grid system to begin systematically working through valves by grid using no other criteria other than the map.

If data exists however, a local operating unit may wish to sequence the grids to focus on any of the following areas first:

- Where there have been a high frequency of main breaks;
- Valves in the oldest part of system;
- Beginning at the source of supply and moving to the extremities of the system;
- By valve size;
- Where critical customers are located;
- Customer density (when starting a program, the local operating unit may wish to inspect and operate valves in low density areas first because fewer customers would be put out of service as a result of breaking a valve);
- Where valve density and redundancy exist;
- Hydrant auxiliary valves where hydrants are thought to be vulnerable to failure (high traffic areas, hydrants used by municipality on regular basis, i.e., street sweepers, fire trucks).
- Valves in areas of proposed upcoming pipe replacement and rehabilitation

At the same time, it is recognized that many local operating units have pre-existing programs and employ various methods of inspecting and operating valves within their respective areas. Accordingly, the following guidance is offered to these areas as opportunities to improve a pre-existing program:

#### How to Improve a Pre-Existing Valve Program:

1. Identify individual valve criticality in accordance with the *Practice: Reliability Centered Maintenance* and apply applicable maintenance frequencies that are indicated in the table in Appendix A;
2. Update/expand database attributes;
3. Examine areas with substantial network activity;
4. Coordinate program with external programs, e.g. repaving projects; external construction activity;
5. Coordinate program with other internal programs, e.g. hydrant inspection and flushing, internal construction activity;

**NOTE** – In performing any valve work, the local operating unit must consider the impact on water quality. For example, there may be an impact in the system where, during the operating of a blow-off valve, the flow of water stirs up sediment in the main. Water quality may not be affected where the operating of a valve does not result in flow velocities sufficient enough to stir up sediment.

## (OP-16) Exercising Line Valves

The first step in developing and implementing a valve exercising program is the location of the valves on the system map.

When inspecting and operating valves, it is recommended that the following information is captured. However, this Practice recognizes that for local operating units beginning a program, all of this information may not be practical to gather initially. Accordingly, for the local operating unit starting a valve maintenance program, it is recommended that the information appearing in bold be captured:

### Attributes for Valves:

1. **Valve ID**
2. **Legacy Valve number**
3. **Location**
  - street name;
  - closest street address #;
  - cross street;
  - **reference dimensions** (distance, direction, reference point);
  - map page;
  - **valve book page;**
  - GPS coordinates;
  - city;
  - county;
  - **municipality;**
  - subdivision;
  - sketches, if available.
4. **Valve size (2" -60")**
5. Operating nut size
6. **Valve type (gate, butterfly, ball, etc.)**
7. Actuator type (manual, electric, hydraulic, pneumatic, etc.)
8. Gear type (non-rising stem, worm, spur, rising stem, etc.)
9. Operating nut type (square, tee head, wheel, etc.)
10. Pressure class (150, 200, 250, 300, 350)
11. **Bypass valve present? (yes or no)**
12. Seat type (resilient, bronze, CI)
13. Joint type (MJ, push-on, lead, restrained, flanged, compression)
14. **Open direction (left, right)**
15. **Normal position (closed, open)**
16. **Function (distribution within grid, distribution dead-end i.e. single source, hydrant auxiliary, blow off, bypass, zone separation, transmission, service line, plant discharge, booster station discharge, pump discharge, raw water, plant)**
17. Type of access (valve box, manhole, vault, pit box, stop box)
18. System monitor installed on valve? (yes or no)
19. Special valve box lid or marking? (yes or no)
20. Marking and access notes (free form)
21. Normal system pressure
22. **Number of turns by design (i.e. from full open to full closed)**

(OP-16) Exercising Line Valves

23. Top of main depth
24. Operating nut depth
25. Criticality (high, medium, low)
26. Criticality Identifier (drop down list)
27. Criticality Notes (free form)
28. Installation date
29. Manufacturer
30. Manufacturer model
31. Manufacture date
32. Manufacturer torque limit
33. Surface Cover Location Type (street, driveway, parking, sidewalk, other)
34. Surface Cover Material Type (concrete, asphalt, grass, landscaping, gravel/stone, soil, brick)
35. Installation Work order number
36. Status of the asset (active, retired in place, retired & scrapped, transferred, pending, etc.)
37. Inspection Route number
38. Inspection Stop/Sequence number
39. Main size (2"-60")
40. Main type (Cl, DI, AG, PVC, HDPE, Steel)
41. Data collected/last updated by (person's name and company)
42. Date collected/last updated

Inspection Data for Valves:

1. Number of turns operated
2. Minimum number of turns for regulatory compliance (if applicable)
3. Torque applied (maximum value or torque curve, if available)
4. Type of operator utilized (valve key, hydraulic operator)
5. Inspection completed by (person's name and company)
6. Time spent to operate valve
7. Position valve left in (open, closed)
8. Initial direction operated (left, right)
9. Direction operated to open (left, right)
10. Position found in (open, closed, partially open)
11. Traffic control utilized
12. Date and time operated
13. Deficiencies noted
14. Any repair work performed at time of inspection
15. Additional repair work required (paved over, box broken, etc.)
16. Was valve operated per procedure? (yes or no)
17. Permit required for operation? (yes or no)
18. Permit number
19. Permit number expiration date
20. System Monitor present? (yes/no)
21. System Monitor adequately marked? (yes/no)

## (OP-16) Exercising Line Valves

Valve Exercising Program - Frequency Table - APPENDIX A

Activity/Task	Criticality	Frequency		Work Load		Specialty Tools/Skills	Comments
		Trigger	Value	Hours	#Staff		
Inspect and Operate distribution system transmission valves	High	Time	Annually	1	1-2*	Valve key/operator	Increase reliability, reduce failure, extend valve life
	Medium	Time	Every 2 yrs	1	1-2*	Valve key/operator	Same
	Low	Time	Every 6 yrs.*	1	1-2*	Valve key/operator	Same
Locate distribution system valves	High	Time	Annually	0.25	1	Map, magnetic locator, valve sketch, valve box cleaners	Ensure accessibility
	Medium	Time	Every 2 yrs	0.25	1	Map, magnetic locator, valve sketch, valve box cleaners	Ensure accessibility
	Low	Time	Every 5 yrs.*	0.25	1	Map, magnetic locator, valve sketch, valve box cleaners	Ensure accessibility
	Low	Activity (new paving, const., etc.)*	Within 1 yr. of activity	0.25	1	Map, magnetic locator, valve sketch, valve box cleaners	Ensure accessibility
Inspect and Operate distribution system valves	High	Time	Annually	0.33	1-2*	Valve key/operator	Determine accessibility and operating condition
	Medium	Time	Every 2 yrs	0.33	1-2*	Valve key/operator	Determine accessibility and operating condition
	Low	Time	Every 5 yrs.*	0.33	1-2*	Valve key/operator	Determine accessibility and operating condition
Inspect and Operate hydrant auxiliary valves	High	Time	Annually	0.33	1-2*	Valve key/operator	Determine accessibility and operating condition
	Medium	Time	Every 10 yrs.*	0.33	1-2*	Valve key/operator	Determine accessibility and operating condition
	Low	Time	Every 10 yrs.*	0.33	1-2*	Valve key/operator	Determine accessibility and operating condition

**NOTES TO APPENDIX A**

This table indicates the valve maintenance activities to be performed, the frequency that the activities should be performed based on valve criticality rating, the estimated number of hours and staff members needed for the work, and the need for any specialty tools/skills.

In the column marked "Work Load," the Practice sets forth an estimate for the hours required for the maintenance work along with an appropriate number of employees to perform said work. In reviewing these guidelines and in determining the proper number of employees needed, a supervisor should consider the individual characteristics of the needed maintenance including the traffic conditions, safety of employees in the given area, and the difficulties that may be anticipated because of valve size, condition, location, and any other relevant information. The estimations are not meant as the enactment of any rule upon supervisors. Rather, the estimations are meant as a guide.

Additionally, the following criteria are offered for supervisors when applying the Frequency Table:

- The triggers for locating low criticality valves are paving reconstruction programs, new construction projects, main extensions, etc;
- The Practice attempts to provide a general framework for valve inspection even though local and/or state regulatory requirements may differ. Where such regulatory requirements differ, it is suggested that the implementation of this Practice may encourage regulatory agencies to reconsider the requirements that the law may currently impose. In other words, the regulations may be antiquated and not reflect current practice in the water industry. The successful implementation of a valve maintenance practice that differs in some manner from the regulatory requirements may support modifications in the regulatory environment.
- Frequency value for operating and locating low criticality transmission or distribution system valves (every five years) is the recommended value. Varied state regulatory compliance issues are to be considered when determining the actual frequency value to be implemented at a specific operating unit.
- Frequency value for operating hydrant auxiliary valves (every ten years) is the recommended value based on the scouring action of valve seats during hydrant inspection. Varied state regulatory compliance issues are to be considered when determining the actual frequency value to be implemented at a specific operating unit.

**Appendix B: Valves Needing Special Operational Consideration**

<b>Function:</b>	Transmission, Discharge of Plant, Booster Station, or Pump Valves	Zone Separation Valve	Single Source (dead end), "Distribution" or service line valves
<b>Normal Position:</b>	Open	Closed	Open
<b>Operation Steps:</b>	Operate a minimum 15% and a maximum of 25% of total turns if critical but a full close & full open if non-critical	Operate slowly to full open and back to full closed while monitoring and controlling pressure on low side by flowing hydrant on low pressure side of valve	Operate a minimum 15% and a maximum of 25% of turns.

## (OP-16) Exercising Line Valves

Along with locating the valves on the system map is the gathering of valve data. Once the valves have been placed in the ground the valve size and valve operator data may be all that can be obtained, thus it is critical that valve information be obtained and recorded prior to installation. The valve data can be recorded on valve cards or in a computer database. In either case it is desirable to develop a valve identification access of valve data method to allow easy

There are a wide variety of valve numbering methods used in the water works industry. Several of these are developed in conjunction with the numbering of lines and fire hydrants. Below are several examples of methods used by different utilities

### Sequence Method

#### Start at 001

The simplest method is to start at the water source with the number 001 and number the valves in sequence from the start point to the end of the system. This method only works well on very small systems where future expansion is limited.

#### Advantage

The main advantage to this system is its simplicity.

#### Disadvantage

The major disadvantage is the difficulty of adding numbers to valves that are installed after the numbers have been established. One method of dealing with this possibility is to use a larger number, four, five, or six digits and leave space between each number. For example start with 1010 as the first valve and 1020 as the second valve, 1030 as the third valve, etc. This leaves 9 digits between each number for future expansion.

### Map Grid Method

This method uses a seven character alpha numeric identification number. The number locates the valve on a specific page of the system map. The same system is used to identify fire hydrants. In this system, the first digit indicates that the asset is a either a fire hydrant (5) or valve (6). The next three digits identify the map number for this asset. The fifth digit identifies the grid letter on the map where this asset can be located. The last two digits are used to identify the specific fire hydrant or valve on this map. In the example below, the number is for a fire hydrant located on map 21D, in grid K, and hydrant 15 within map 21D.



(OP-16) Exercising Line Valves

Asset ID number for Fire hydrants & valves

**5 21D K 15**

Unique hydrant #

Grid letter on map

Map #

Area (5= hydrants; 6 =valves)

**System Explanation Expanded**

In this system; each map page is divided into blocks starting in the upper left corner with A. Within each block the hydrants are numbered starting with 1 for the hydrant located in the upper left of the grid and proceeding across the top from left to right of the grid, then dropping down one row and moving back to the start from right to left.

**Advantage**

The major advantage to this system is the ease with which a valve may be located on the system map.

**Disadvantage**

The disadvantages to the system are:

- The time required to establish the number system.
- The difficulty in locating the valve on the ground.
- The difficulty in numbering valves added to the system when the valve is located between two existing valves.

**Street Address Method**

**Explanation-**This method is used to identify line valves and fire hydrants. The first character is either a "V" for line valves or an "H" for hydrant. The next two characters identify the street where the hydrant or valve is located and the last four characters is the street address.

**Asset ID number for valves**

V LV 4079

Address

Street ID

Code

V for valves

For example: HLV4085 for a hydrant located at 4085 on Lummi View. VL4079 is for a valve located at 4079 Lummi View.

### (OP-16) Exercising Line Valves

#### Advantage

The main advantage to this system is the ease with which the valve can be located on the ground.

#### Disadvantage

The main disadvantage to this system is the time required to establish the number for each valve as a site visit is required for each valve.

#### Line Segment Method Defining Line Segments

In order to enter distribution lines into an asset database or a hydraulic model each segment of a line must be numbered. A line segment is a line that is of the same size and material type that extends from one definable point in the system to another. A definable point would include fire hydrants, elbows, PRV stations, line valves, etc. In the example shown on the map on the next page, the line segments are identified with five characters. The first character is the letter "L." The next character is a number indicating which street where the line is located. This is followed by three digits.

#### Valve Numbers

Four characters are used to identify valves. The first character is the letter "V" followed by three numbers. The first digit of the number is the same as the first digit of the line segment number where the valve is located. Note that most of the numbers are spaced by ten digits. However, when two valves are located one each side of a tee the spacing is only one digit. This is a numerical method of indicating these two valves are located physically close to each other. Also note on the map valve numbers are placed inside of a hexagon (six sided figure) while hydrant numbers are placed inside of a circle. A map showing this method is located on the next page. This map is reduced by to 55% of the original size. A 100% view of a portion of this same map is located on page 18 of this text.

#### Advantage

The main advantage to this system is ease of relating a specific valve to a line and thus a street. While the number does not provide the same degree of clarity of physical location as the street address method it does provide information on the specific street the valve is located.

#### Disadvantage

The disadvantage to this system is the time required to number the valves and the difficulty of locating the valve physically on the ground.

(OP-16) Exercising Line Valves

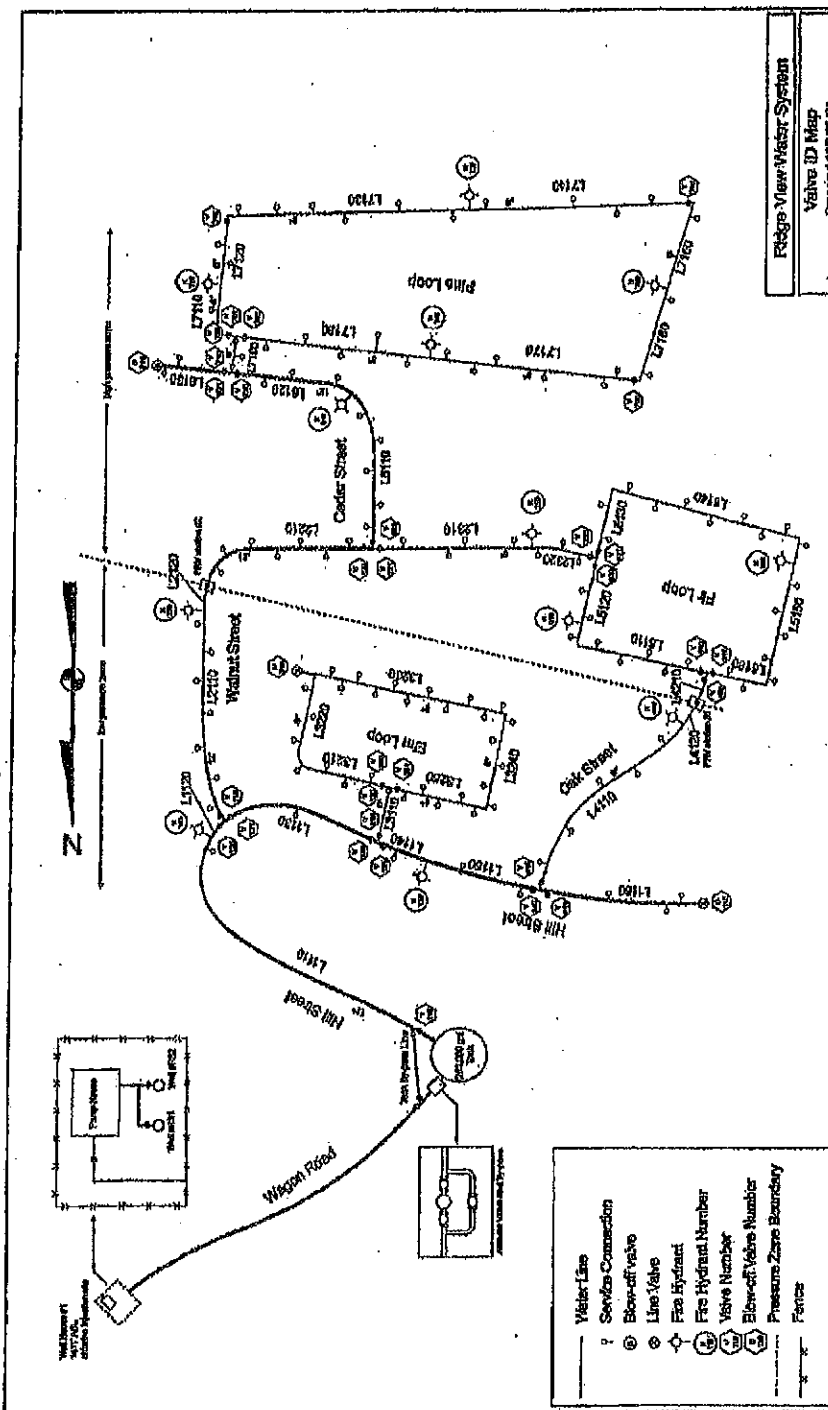

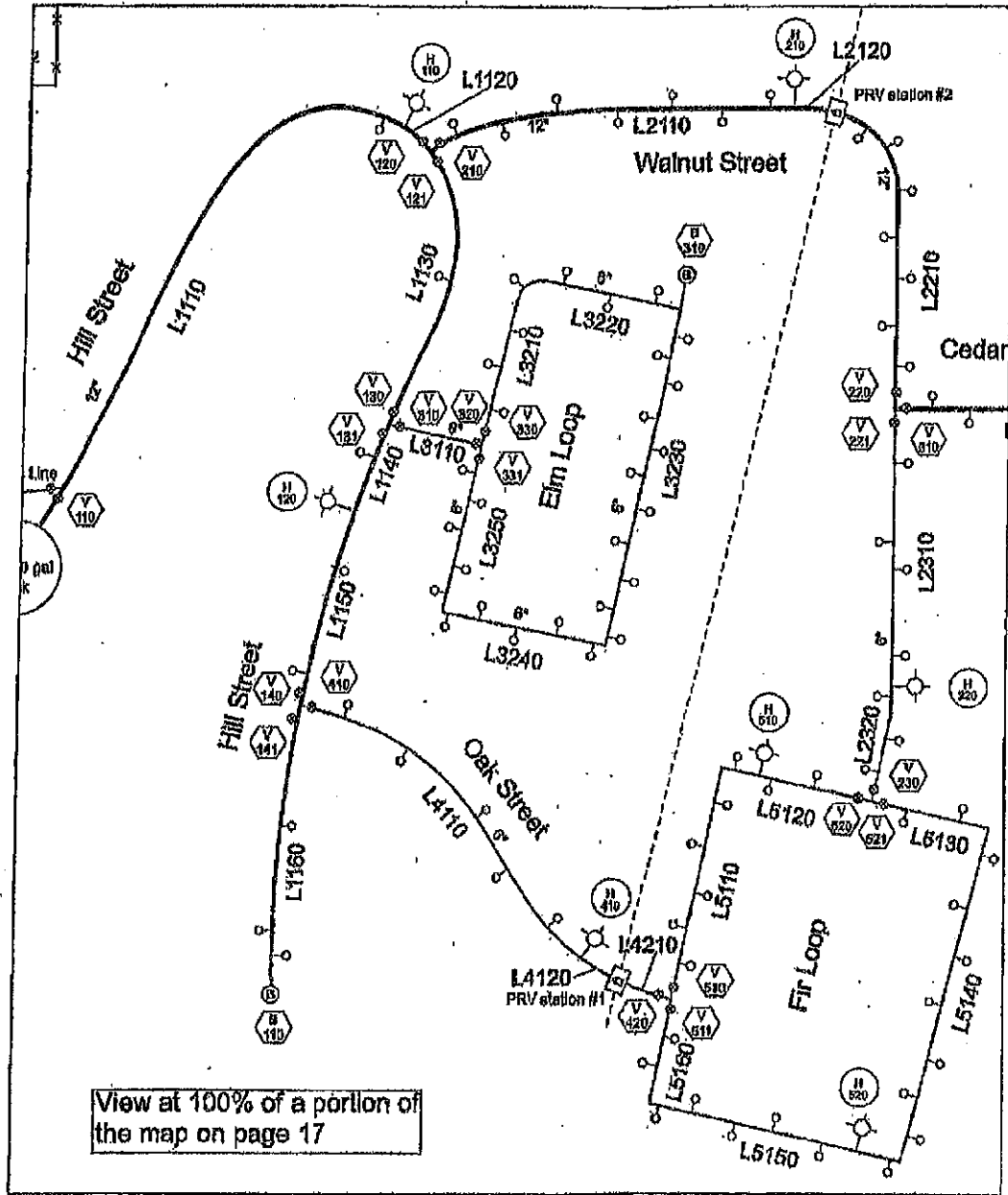

### Field Activities

#### Equipment and Personnel

A two person crew may be best for performing this task in high traffic areas. One person spends a considerable amount of time handling the traffic while the second person locates and exercises the valve. The individual/s must be familiar with the distribution system, valve location, critical users, special pressure zones and pump stations. The equipment requirements include:

- Valve wrenches - at least 2
- Radios for communication between the two crew members'
- Valve box cleaning tool
- The system map and valve exercise report form
- Traffic control equipment
- Valve box location equipment

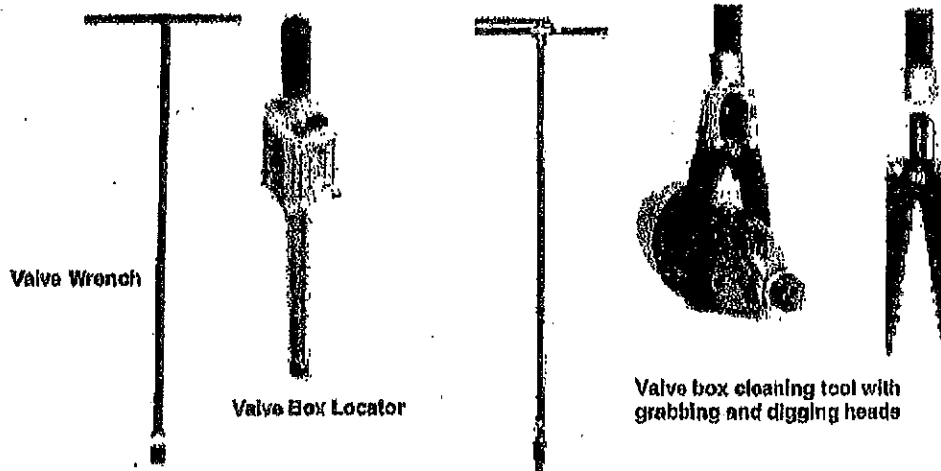

#### Precautions

When undertaking a line flushing program, there are several precautions that should be considered.

Turning valves on and off may cause sudden shifts in system pressure. This can cause problems with customers' equipment, PRV stations, booster stations and SCADA systems. It is critical that normally open valves not remain in a closed position any longer than necessary.

#### Pressure Changes

When large gate valves are closed the difference in pressure from one side of the valve to the other may be so great as to make it very difficult to open the valve. Until the valves are exercised at least once this information will not be known. It is always a good idea to place a pressure gauge on a fire hydrant or customer service just down stream of a major

main line valve. As the valve is being closed, observe the pressure drop, if it appears that the pressure will drop below 20psi do not close the valve completely

**Butterfly Valve Vibration**

The gear train on a butterfly valve may become worn with time. As a result the movable closure will vibrate as the valve approaches full close. In this case it is best to quickly open or close the valve.

**Valve Won't Close**

It is very common for gate valves to not fully close. When this occurs, DO NOT force the valve. Forcing the valve can bend the disk of the movable closure. The most common cause of this problem is debris in the bottom of the valve body preventing the disk from reaching the bottom of the valve. To resolve this, open the valve slightly, this will cause a high velocity flow under the disk and, in most cases, will clear the debris from the valve body.

**Field Sequence**

**Valve Inspection and Operation Procedure**

Primary tasks for all Valves:

1. Locate valve (verify measurements, GPS coordinates, landmarks);
2. Set-up traffic control and observe applicable safety procedures;
3. If data exists, review valve size, valve type (butterfly, gate, etc.), the number of turns required to fully open or fully close valve, function of valve (transmission, hydrant auxiliary, distribution, zone separation, single source supply, etc.), direction to open, and normal position. Note – If any information listed above is missing, then the valve should not be exercised, and report these findings to the employee's supervisor;
4. Ensure valve operation will not cause damage to the distribution system by identifying critical areas and taking extra precautions (It is important that valve inspections are coordinated with the Production Department)
  - Valves in the vicinity of pumping/booster stations, pressure zone valves, transmission valves, and single source valves are examples of critical areas;
  - Examples of extra precautions include communication and coordination with the production department and the installation of temporary pressure relief devices or bypasses.
  - Verify whether system monitors, like acoustic monitors for leak detection, are in the area and, if so how they are marked in the field.
5. Remove valve box lid. If system monitors are located in valve boxes, exercise care in removing the valve box lid because instrumentation and wiring may be attached to the lid. The system monitor is generally attached magnetically to the top of valve nut and needs to be removed prior to operation of valve. Report any damage to your supervisor and the appropriate Non-Revenue Water management staff;
6. Clean out the valve box if necessary;
7. Insert valve key onto valve nut, wheel, or tee head;
8. Except as otherwise indicated in Appendix B, operate valves through a full cycle and leave in normal operating position (note: one should consult local procedure on effective valve operating);

(OP-16) Exercising Line Valves

9. Count the number of turns and compare with manufacturer specifications;
  - A. If number of turns is not within 90% - 100% of manufacturer specifications then operate valve full cycle two to three more times. If the number of turns does not change, the operator should notify their supervisor.
  - B. If number of turns exceeds 100% of manufacturer specifications, the operator should stop valve operation and notify their supervisor that the valve may be broken.
10. Record inspection data and refer to "Inspection Data for Valves" in the Reporting Metrics Section of this Practice;
11. Update valve attribute data to make corrections or additions;
12. Restore the valve lid and clean up area if necessary; if present, restore the system monitor, checking for good contact with the valve nut. If monitor is damaged or if unsure of whether the unit was properly restored, contact your supervisor and the Non-Revenue Water management staff.
13. Remove the traffic set-up.

Optional tasks:

At the same time, the Practice recognizes that many local operating units may wish to pursue additional steps during valve inspection. Below are optional tasks that may be pursued:

1. Open downstream hydrant during valve operation (to scour valve seat, verify positive shutdown, discover any closed valves, etc.) record lost water. If hydrant is fully inspected at time of valve operation, then record hydrant inspection data in accordance with *Practice: Hydrant Operation, Inspection and Maintenance*.
2. Sound the valve when fully closed, open the valve and resound valve.

Number of Turns to Operate a Double Disk Gate Valve			
Valve Size	Number of Turns	Valve Size	Number of Turns
3"	7 1/2	12"	38 1/2
4"	14 1/2	14"	46
6"	20 1/2	16"	53
8"	27	18"	59
10"	33 1/2	20"	65

**Special Note for Gate Valves:**

If the valve is to remain in an open position, open it fully and then back off of open 1/4 turn. If the valve is to remain closed, close the valve and then back off 1/4 turn. By leaving the valve 1/4 turn off of stop the next user of the valve can easily determine if the valve is being turned in the correct direction.

**AW Valve Operation, Inspection and Maintenance Practice**

**Possible maintenance problems associated with valve operation and inspection**

1. Valve packing leaks on single or double disc valves that have graphite packing.
2. Valves may be broken open or closed during valve operation.
3. Broken gate could cause a sudden water hammer resulting in a main leak.
4. Valve boxes and valve box lids may get broken attempting to gain access to the operating nut.
5. Square operating nut is rounded -- valve key just spins on nut.
6. Wheel on wheel valve is missing.
7. Valve is inoperable -- can't turn operating nut or wheel.
8. Valve box is off center -- can't position valve key on operating nut or wheel.
9. Valve box is paved over, covered, filled with sand or dirt.

**Contingency parts & maintenance materials list**

1. Graphite valve packing -- 1/4", 3/8", 1/2", etc.
2. MJ gate, MJ butterfly, & tapping valves in stock - various sizes Ductile Iron or C900 PVC pipe and fittings in stock (MJ solid sleeves, MJ dual purpose solid sleeves, bolted couplings, transition couplings, mega lugs, retaining glands, etc.) -- various sizes. Inventory of square operating nuts and wheels (usually removed from existing valves that are retired and removed).
3. Valve boxes, lids and valve box paving risers (various riser heights -- 1" -- 4").
4. Restoration materials (temporary paving, clean fill, gravel, DGA, etc.).
5. Repair clamps -- (360° stainless steel, bell joint, etc. -- various sizes).



(OP-16) Exercising Line Valves

INSERT VALVE DATA COLLECTION FORM