

Electric Service Guide for Commercial Construction

Table of Contents

- Contacting KCP&L 2
- Voltages 2
- Temporary Service 2
- Current Transformers 2
- Inspections 2
- Planned Outages and Line Coverage's 2
- What You Need to Know Before You Call 3
- Typical Steps for Service Alterations 3
- Typical Steps for New Commercial Construction 3
- KCP&L Services at a Glance 4
- Anticipating and controlling costs 5
- Standard Charges 5
- Glossary of Terms 5
- KCP&L Approved Commercial Meter Sockets 6
- Quick Overview of Construction Process 6

Energizing Life: A commitment that goes beyond reliability

At KCP&L, we have worked hard to build one of the best reliability records in the industry. We want to make sure you have the service you need, when you need it. Whether you are remodeling an existing building or building a new one, this brochure is your guide to energizing your project from start to finish.

CONTACTING KCP&L

When you are ready to start your project, call KCP&L. Our toll-free numbers for all locations are listed below. We will connect you to our nearest office for scheduling and assistance throughout your project.

Most construction or service upgrades can be managed on line at kcpl.com, including ordering a new service meter, removing a temporary meter, upgrading an existing service or obtaining a complete copy of KCP&L's current Electric Service Standards. If you need to speak to a customer care representative please call (816) 471-KCPL (5275) or (888) 471-KCPL (5275).

VOLTAGES

Single-phase, 60 Hertz, 120/240 volts, three-wire

Single-phase, 60 Hertz, 480 volts, service, three-wire.

Three-phase, 60 Hertz, 240 volts or 480 volts three-wire (overhead transformation only)

Three-phase, 60 Hertz, 120/208 volts or 277/480 volts, four-wire

Under certain conditions, primary service at three-phase, 60 Hertz, 7200/12,470Y, 7620/13,200Y, 14,400/24,900Y, and 19,900/34,500Y volts, four-wire

TEMPORARY SERVICE

Customer-Provided Temporary Service. This is generally 120/240 volt, 3-wire service, although other voltages may be available. Inspections by the governing agency and by KCP&L are required before KCP&L can connect this type of temporary service.

Customer-Owned Temporary Service

Jurisdiction	Prior to May 22, 2017	Effective May 22, 2017
KCP&L - KS & MO	\$350*	\$350*
KCP&L - GMO	n/a	\$300

*\$380 in Olathe, KS

KCP&L-Provided Temporary Service. This is available in 120 volts, so only 120-volt equipment can be operated from this temporary service. No city or county inspection is required.

If your project calls for voltages other than 120 or 240 volts, availability is limited to the current voltages at your construction site. If no secondary voltage is available, you will need to order a construction project to build the desired service. A construction project requires additional time beyond the standard time for temporary service. Construction time and material charges are billed if temporary facilities are not used as part of the permanent service.

To avoid construction delays, contact KCP&L as soon as you know that temporary service is needed. Otherwise you may need to use a generator to avoid delays or added construction costs.

KCP&L-Owned Temporary Service

Jurisdiction	Prior to May 22, 2017	Effective May 22, 2017
KCP&L - KS & MO	\$300*	\$300*
KCP&L - GMO	\$100	\$250

*\$330 in Olathe, KS

CURRENT TRANSFORMERS

Current transformers (C.T.'s) are required on single phase service over 400 A and three phase service over 200 A. Installation of CT's requires the customer to provide a CT cabinet and depending on the installation, a splice box, while KCP&L will provide the meter socket and C.T.'s. See illustrations for examples.

CT's are installed with the polarity mark towards the transformer and are separate from other metering and control circuits. Please discuss location of CT's over 800 A with your KCP&L representative.

INSPECTIONS

Virtually every city and county in KCP&L's service territory requires routine inspections of electrical work. The agency conducting the inspection generally is responsible for granting wiring permits. KCP&L cannot connect your electrical service until we have received inspection approval from the governing body that completed the inspection. For exact instructions and requirements, contact your local county or city offices.

PLANNED OUTAGES AND LINE COVERAGE'S

Connection of commercial service will often require a planned outage. A planned outage requires time to coordinate and will likely incur additional costs. Please coordinate planned outages with a KCP&L Designer. Overhead Damage Prevention Acts require notification of electric utilities before working near energized electric lines. KCP&L will cover or deenergized electric lines to provide a safe working zone. Line coverage is coordinated with KCP&L Operations, and will require an on site meeting to discuss the work, charges and time period.

WHAT YOU NEED TO KNOW BEFORE YOU CALL

When you are ready to initiate a project request, call KCP&L or log on to **kcpl.com**. If you call, our representative will take your information and direct your request to the service center nearest to you. To save time and inconvenience, make sure you have the following information before you call:

KCPL account:
Project Name:
Service Address:
Customer Name:
Billing Address:
Date Service Needed:
City:
State:
Zip:

Required Data:

2 copies of final site plan including dimensions, paved areas, preferred meter and transformer locations and property lines. Final Transformer and meter locations are determined and approved by KCPL.

2 copies of electrical riser plan or 2 copies of the one line drawing

2 copies of legal description of the property

Elevation drawing as requested.

One electronic copy (AutoCAD format) of the above project's plan on jump drive, CD, or e-mail.

Project size (sq ft) existing new

of floors

Project Reps

Name/Address/Phone _____

Developer _____

Owner _____

Arch/Eng _____

Gen Contractor _____

Elec Contractor _____

Electrical Data existing kW _____ new kW _____

Air Conditioning _____ # of Units _____ Total Tonnage _____

Lighting Type (T-12, T-8, HID, Incand, LED) _____

Space Heat Type of Heat _____

Motors Total Largest Motor hp _____

Computer Equip (PC, LAN, Mainframe) _____

Cooking Type (lunch, café, break) _____

Misc Equip (outlets, special) _____

Total _____

Connected Load _____

Estimated Diversified Demand _____

Services:

Overhead / Underground _____
Standby Generation Yes / No _____
Size(s) _____
Connected _____

Service Data
General Meters Heat Meters Other Meters
of Customers _____
Entrance Size Amps _____
Volts/Phase/Wires _____

If you prefer, you can fax your information to KCP&L at **(816) 654-1125**. Please provide a complete description of your project including all the information listed above. Be sure to include your daytime and evening telephone numbers so that we can reach you if there are questions.

TYPICAL STEPS FOR SERVICE ALTERATIONS

Follow these simple steps to make the job efficient and hassle-free.

Step 1—The Permit. Obtain the necessary wiring permit at your municipal or county offices.

Step 2—Initiate Your Service Request. With permit in hand, call KCP&L, or enter your request online at **kcpl.com**. Be prepared with all the information as listed in the **What You Need To Know Before You Call** section. Our representative will take your information and enter it into our system for scheduling.

Step 3—KCP&L Service Visit. A Service Designer will visit your service address to inspect the project and determine the best location for the new meter socket.

Step 4—Inspection. Once the electrical work is completed, inside and out, call your electrical inspector's office for a safety inspection. This must be completed before KCP&L can reconnect your service. The inspector will contact KCP&L to approve connection, generally the following working day. Depending on complexity, we may need to inspect the alteration outside your business one last time.

Step 5—Connect Service. KCP&L will schedule a construction crew to connect your altered service following receipt of your governing agency's approval. A planned outage may be required if other commercial customers are connected to the same transformer and will likely incur additional charges.

TYPICAL STEPS FOR NEW COMMERCIAL CONSTRUCTION

New construction is hectic enough without last minute surprises. Here are some tips to help you understand what you need to do for temporary and permanent electric service.

Step 1—Initiate Your Service Request. Call KCP&L or enter your request online at **kcpl.com** as soon as possible to get your service order started. Be prepared with all the information in the **WHAT YOU NEED TO KNOW BEFORE YOU CALL** section. Our representative will take your information and enter it into our system.

Step 2—Survey, Legal Description, Riser Diagram, Civil Site Plan and Service Application. Copies of your property’s legal description and plot plan are needed by KCP&L before electrical service planning for new construction can begin. Both should have been provided to you at closing. Together these documents help KCP&L identify utility easements, property corners, building setbacks distances and more.

In addition, your property should have ground stakes or metal rods for locating the corners. Often they are just below the surface. If they cannot be located, you may need to have the property surveyed and a copy of the survey sent to KCP&L.

Step 3—Temporary Service During Construction. There are two types of temporary electric service: customer-provided or KCP&L-provided service. Discuss with your Commercial Representative to see if available.

Step 4—KCP&L Service Visit. A Service Designer will visit your service address to inspect the project. KCP&L will make every attempt to keep the transformer at the desired location. A KCP&L Designer will create a construction drawing for your review and approval signature.

Step 5—Conduit Locations. Survey conduit locations and send to KCP&L for use in easement documents.

Step 6—Sign easements and return to KCP&L. Easements are sent to the owner for signature. Return signed easements in a timely manner to avoid construction delays.

Step 7—Submit associated costs for construction The customer is responsible for the difference between estimates of the load and cost associated with the project. Contact your commercial service representative for details. Payments are needed prior to scheduling of construction crews.

Step 8—Inspection. Once the electrical work is completed, inside and out, call your electrical inspector’s office for an inspection. This must be completed before KCP&L can connect your service. The inspector will contact KCP&L to approve the connection, generally the following working day. KCP&L will then conduct their inspection.

Step 9—Service Connection. Depending on the extent of the work, your new service will be scheduled for connection in the next 3 to 4 weeks.

Before you call

Once again, you can initiate your project request by calling KCP&L or online at **kcpl.com**. If you call, our representative will take your information and direct your request to the service center nearest to you.

KCP&L SERVICES AT A GLANCE

Most construction services surrounding temporary or permanent connection of electric service are performed by KCP&L. Others are the responsibility of the property owner and should be done by a licensed electrician. Certain services performed by KCP&L involve materials or labor and will result in a minimum charge.

Services which are the responsibility of the customer or their contractor
Provide and install meter socket OR Splice box and CT cabinet, KCPL provides the C.T.’s and meter socket.
Provide service entrance wire.
Provide and install riser, weatherhead and riser wire for overhead service and service hook(s).
Provide trench and lay conduit with heavy pull cord for primary underground service
Provide conductor from transformer to building for secondary underground service.
Trim trees as needed.

Once the electrical work has been completed, inside and out, call your electrical inspector’s office for an inspection. This must be completed before KCP&L can connect your service. The inspector will contact KCP&L to approve the connection, generally the following working day. Depending on complexity, we may need to inspect the outside of your business one last time before scheduling a construction crew to connect the service.

Remember to have the temporary service meter removed if it is no longer needed.

ANTICIPATING AND CONTROLLING COSTS

The decisions you make regarding service size and distribution can result in additional construction charges. Costs to provide service in rural settings can be higher than in cities where distribution lines are closer and more readily accessible. Start planning early and have your KCP&L representative help you identify potential costs, and how you can control them. Visit KCP&L.com and follow the link at the bottom of the page to the Construction Standards for the latest edition of our Electric Service Standards.

STANDARD CHARGES

KCP&L - GMO service area (formerly served by Missouri Public Service & St. Joseph Light & Power)		
STDOHUG	Conversion of existing overhead service to underground service	\$480
STDUGOV100	Excess of 100' underground service charge	\$2.52

KCP&L Kansas & Missouri Service Area		
STDMV1OH	Moving one end of existing overhead service drop (Updated to 2 hours)	\$200
STDRPLCOH	Replacing an existing overhead service drop	\$485
STDUGOHDIS	New permanent underground service from overhead distribution	\$505
STDOHUG	Conversion of existing overhead service to underground service	\$745
STD+SECPED	Additional charge where a new secondary pedestal is required	\$300
STDALTUGNW	Major alteration of existing underground service where new cable is required	\$440
STDUGOV100	Excess of 100' underground service charge	\$1.35
STDALTUGCP	Minor alteration of existing underground service where no new cable is required and all excavation is completed by customer	\$295
STDREVCNCL	Design time for revisions or cancelled jobs	\$50

GLOSSARY OF TERMS

Alteration. Any change in the electric service. Although this is generally an upgrade in the service panel—from fuses to breakers, main switch size from 60A to

100A or 200A—it also can be a change from overhead to underground service. Relocating the service to accommodate a new room or deck is another example. A fee may be charged.

Ampere (amp, A). The standard unit for measuring strength or rate of flow of an electric current. Also the measure of commercial electric service. (100A or 200A, etc.)

CT's (current transformers). Current transformers convert the flow of electrical current at the input to a different level of flow at the output.

Customer Provided Temporary Service. A metered service, usually 120/240V, provided by the customer during construction. Voltages may vary as determined by availability and the customer.

Service Hook. A device anchored to a building, which supports the overhead service drop. The device must be able to support a 900-pound stress.

Inspection. An inspection of a completed electrical project is the responsibility of the governing body for that area. Once approved, the inspecting agency will notify KCP&L. We cannot connect permanent service without approval.

KCP&L Provided Temporary Service. No city or county inspection is required for this type of service.

Meter socket. A metal box fitted with a sealed, removable lid into which the electric meter is placed.

National Electric Code (NEC). A procedural guide for wiring projects used by all governing bodies to ensure proper, safe and consistent wiring practices by homeowners and electricians. The governing bodies themselves, however, have final authority to approve or deny electric service.

Overhead Service. Also called a service drop, this system delivers electric service from the pole, through suspended wires, to a home or building.

Permit Number. The number issued when a permit is purchased prior to starting any electrical wiring project. These are required in most areas.

Planned Outage. Electrical power is shut off to perform work during a scheduled period of time.

Riser. A vertical PVC (plastic) or metal pipe mounted on top of the meter socket to protect and insulate the service entrance wires.

Riser Diagram. A diagram showing the electrical service and connections.

Rubber up. Placing insulators on electrical lines to protect against incidental contact with the lines.

Underground Service. Power lines buried and encased in PVC (plastic) that delivers electric service from pole, transformer or secondary pedestal to a home or building.

Weatherhead. A PVC (plastic) or metal cap at the top of the riser that prevents water from entering the meter socket.

KCP&L APPROVED COMMERCIAL METER SOCKETS

Visit KCPL.com and follow the link at the bottom of the page to the Construction Standards for the list of approved meter sockets.

QUICK OVERVIEW OF CONSTRUCTION PROCESS	
This is the sequence of activities that occurs for new construction projects.	
STEP	ACTION OR INFORMATION REQUIRED
1	Customer calls KCP&L's Customer Care Center at (816) 471-5275 or enters service request online at KCPL.com . KCP&L recommends you request both temporary and permanent service at the same time.
2	Service request is sent to your nearest KCP&L service center.
3	KCP&L makes a field visit to confirm that power is available to your site or to determine what will be needed to provide it.
4	KCP&L contacts you for your power requirements—including size and time or service and to estimate charges if any. You will need to provide riser diagram, legal description, civil site plan (AutoCAD format) and service application. Your KCP&L rep will provide a list of requirements and the proper application.
5	Customer provides signed and sealed (stamped) survey information from a licensed surveyor to KCP&L, if needed.
6	Customer locates and marks property corners.
7	KCP&L completes a construction drawing. A drawing is provided for customer review and approval signature.
8	Customer signs easements and payment for construction costs before construction can begin.
9	KCP&L schedules project for construction after customer's work is completed and has passed KCPL & government inspection.
10	KCP&L connects permanent service after city/county inspection and our own approval.

NOTES

- Meter socket furnished and installed by Customer. Customer shall not use meter socket to enclose or terminate his system ground.
- Insulated bushing furnished and installed by Customer. Do not use center knockout for incoming conduit.
- Position prefabricated conduit slip joint to compensate for soil settling. Leave sufficient slack in service conductors to allow joint to work.
- All conduit — electrical plastic whole-inch size conduit furnished, properly installed, owned and maintained by customer. KCP&L to inspect before backfilling.
- Customer must provide and install cable.
- Leave enough cable for KCP&L to complete the connection at the transformer. Please contact KCP&L when ready.
- Install 2-hole clamp above elbow to foundation.
- Leave clamp loose to allow slip joint to work.
- One hole clamps are not acceptable.

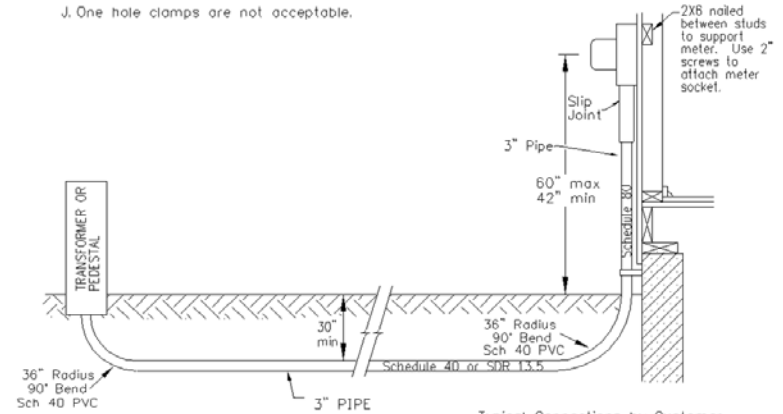

Typical Service Entrance

- Backfill must consist of dirt or sand only. Do not use frozen material, rocks, clads or debris.
- Customer's cable and conduit should be sized and installed to meet National Electrical Code and/or local requirements.

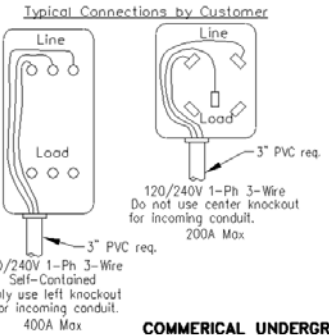

COMMERCIAL UNDERGROUND SERVICES NON-NETWORK 400A OR LESS UNDERGROUND SECONDARIES

DWG REV: 08/13/12 DWG: **820.1-8**

NOTES

- A. Customer to own and install service entrance conductors with a minimum of 24" outside of weatherhead.
- B. Service drop connections by KCP&L.
- C. Customer to own and install the service attachment, such as service hook, wire holder or bracket on mast capable of supporting a 900 pound force. Customer to own and install service mast with entrance head. If the mast extends above the eave of the building, the service should be attached to the mast and the mast must be 2" (min) rigid galv. conduit and guyed or braced as required to support the service. If the service attachment is on the building, the mast may be rigid metal, EMT or Schedule 40 electrical plastic conduit. The height of attachment must provide the clearance to ground or to the roof line as required in the National Electrical Code.
- D. Install meter socket at least 36" away from windows and doors. (KCP&L required)
- E. Customer will furnish and install approved meter socket and hub.
- F. Customer's service entrance conductors and conduit are to be sized in accordance with the NEC.
- G. Customer must not use meter enclosure to terminate or enclose his system ground.
- H. Provide some slack ahead of terminations in the meter socket to allow for future maintenance.
- I. Color-code conductors according to NEC.

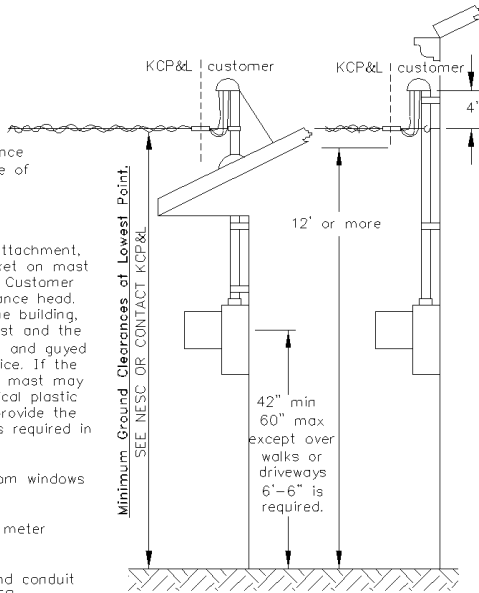

Typical Connections by Customer

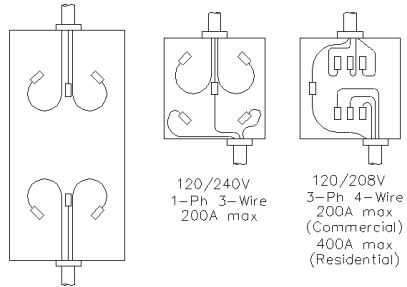

Customer furnished and owned material:

DESCRIPTION
hub
meter socket
entrance head
conduit straps
conductor
service mast
#6 Cu ground wire
1/2"x8" ground rod

**OVERHEAD SERVICES
SELF-CONTAINED
METERS**

DWG REV: 03/29/10 DWG: 520.1-3

NOTES

- A. Approved meter socket furnished and installed by Customer. Do not use meter socket to enclose or terminate his system ground.
- B. Insulated bushing furnished and installed by Customer.
- C. Position prefabricated conduit slip joint to compensate for soil settling. Leave sufficient slack in service conductors to allow joint to work.
- D. ~~Do not~~ Do not use center knockout for incoming conduit.
- E. All conduit—electrical plastic whole inch size conduit furnished, properly installed, owned and maintained by customer. KCP&L to inspect before backfilling.
- F. Commercial customers must provide and install cable, leave enough cable to go up the pole.
- G. KCP&L will provide and install the cable for residential customers.
- H. Install 2-hole clamp above elbow to foundation.
- J. Leave clamp loose to allow slip joint to work.
- K. One hole clamps are not acceptable.

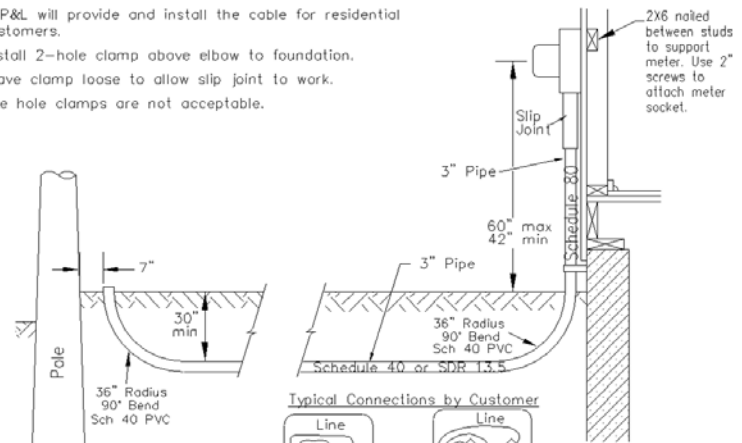

Typical Service Entrance

- Backfill must consist of dirt or sand only. Do not use frozen material, rocks, clods or debris.
- Customer's cable and conduit should be sized to meet National Electrical Code and/or local requirements.

Typical Connections by Customer

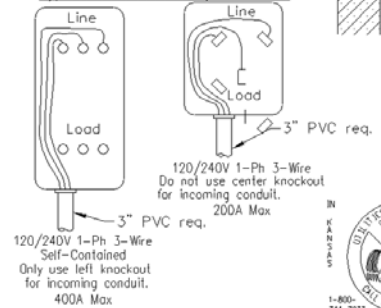

SWITCH SIZE (A)	REQUIRED CONDUIT SIZE	MAXIMUM SERVICE LENGTH
100	3"	180'
200	3"	180'
400	3"	140'

**1-PHASE
UNDERGROUND SERVICES
400A OR LESS
OVERHEAD SECONDARIES**

DWG REV: 08/13/12 DWG: 820.1-9



NOTES

- A. Approved meter socket furnished and installed by Customer. Do not use meter socket to enclose or terminate his system ground.
- B. Insulated bushing furnished and installed by Customer. Do not use center knockout for incoming conduit.
- C. Customer should furnish and install a non-fused 600V outdoor weathertight disconnect on the line side of each meter for KCP&L use.
- D. Position prefabricated conduit slip joint to compensate for soil settling. Leave sufficient slack in service conductors to allow joint to work.
- E. All conduit—electrical plastic whole-inch size conduit furnished, properly installed, owned and maintained by Customer. Allow KCP&L to inspect before backfilling.
- F. Customer must provide and install cable. Leaving enough cable for KCP&L to complete the connection in the transformer. Please contact KCP&L when ready.
- G. Install 2-hole clamp above elbow to foundation.
- H. Leave clamp loose to allow slip joint to work.
- J. One hole clamps are not acceptable.
- K. Call KCP&L for a meeting to pull cable.

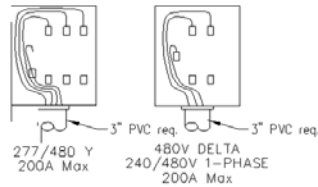
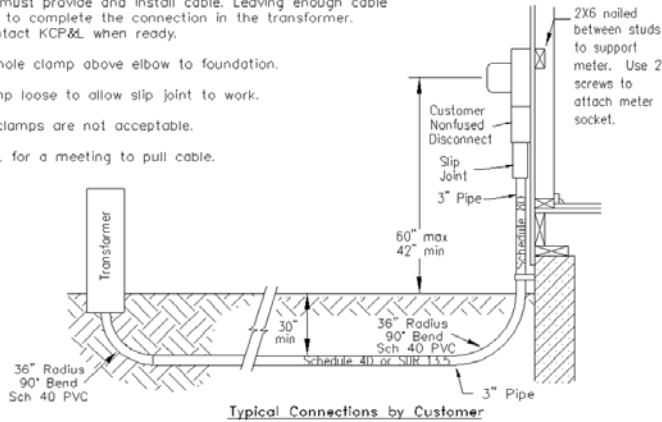

Typical Service Entrance

- Backfill must consist of dirt or sand only. Do not use frozen material, rocks, clods or debris.
- Customer's cable and conduit should be sized to meet National Electrical Code and/or local requirements.

**UNDERGROUND SERVICES TO
3-PHASE 277/480V Y OR
480V DELTA &
1-PHASE 240/480V
SELF-CONTAINED METERING
UNDERGROUND SECONDARIES**

DWG REV: 08/13/12 DWG: 820.1-10

NOTES

- A. Approved meter socket furnished and installed by Customer. Do not use meter socket to enclose or terminate his system ground.
- B. Insulated bushing furnished and installed by Customer.
- C. Do not use center knockout for incoming conduit.
- D. Customer must furnish and install one non-fused 600V outdoor weathertight disconnect per meter on the line side of each meter for KCP&L use.
- E. Position prefabricated conduit slip joint to compensate for soil settling. Leave sufficient slack in service conductors to allow joint to work.
- F. All conduit—electrical plastic whole-inch size conduit furnished, properly installed, owned and maintained by Customer. Allow KCP&L to inspect before backfilling.
- G. Customer must provide and install cable. Leave enough cable for KCP&L to complete the connection. Please contact KCP&L when ready.
- H. Install 2-hole clamp above elbow to foundation.
- J. Leave clamp loose to allow slip joint to work.
- K. One hole clamps are not acceptable.

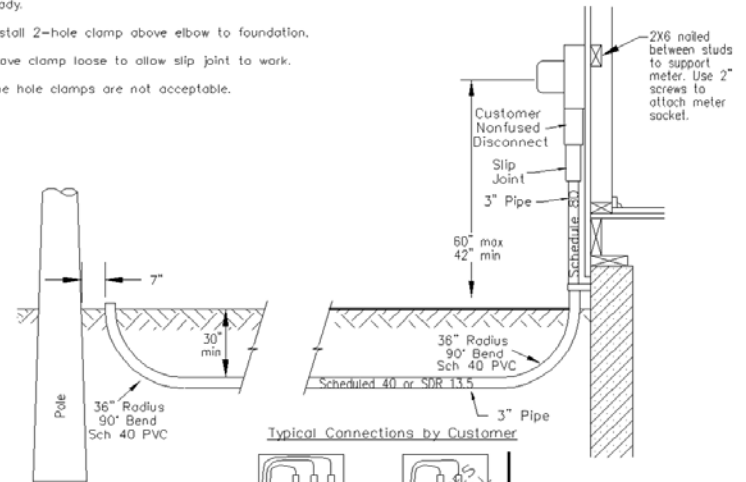

Typical Connections by Customer

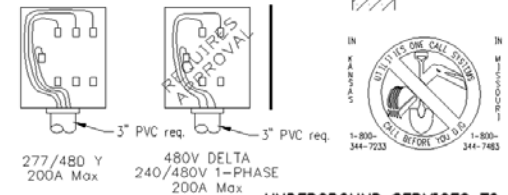

Typical Service Entrance

- Backfill must consist of dirt or sand only. Do not use frozen material, rocks, clods or debris.
- Customer's cable and conduit should be sized to meet National Electrical Code and/or local requirements.

**UNDERGROUND SERVICES TO
3-PHASE 277/480 V OR
480V DELTA &
1-PHASE 240/480V
SELF-CONTAINED METERING
OVERHEAD SECONDARIES**

DWG REV: 08/13/12 DWG: 820.1-11

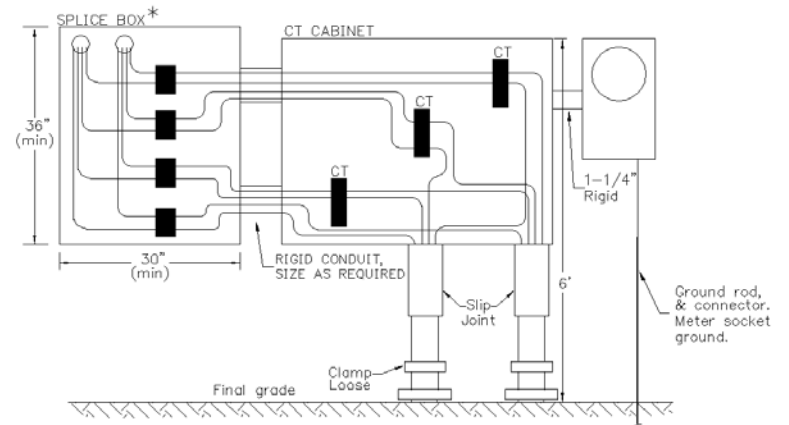
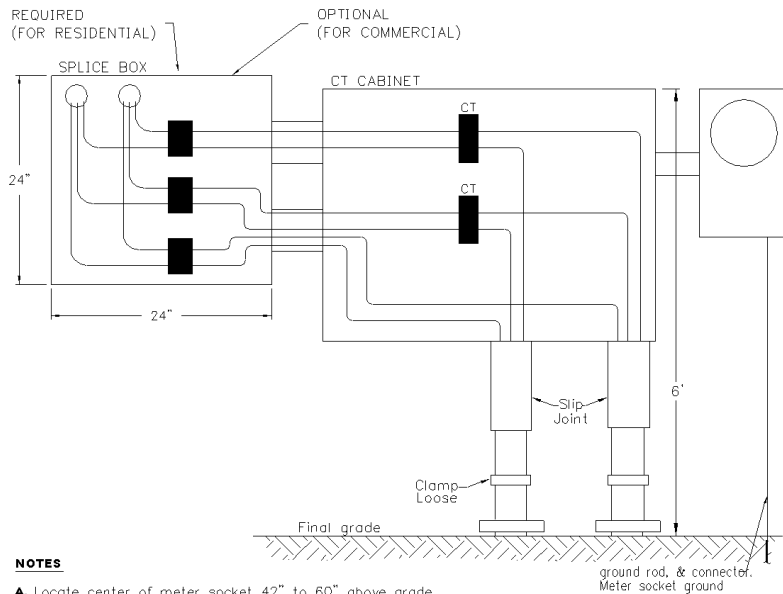

NOTES

- A. Locate center of meter socket 42" to 60" above grade.
- B. Use 1-1/4" rigid metallic conduit to ensure electrical bonding between CT cabinet, meter socket, and splice box.
- C. Ground must not pass through CT cabinet.
- D. Position conduit slip joints to compensate for soil settling.
- E. Do not use non-corrodible 2-hole conduit strap, strut or 1-hole clamps.
- F. Clamp system must be fastened to sill plate.
- G. Splice box and CT cabinet furnished & installed by Customer on outside of building.
- H. Meter can and CTs furnished by KCP&L and installed by Customer on outside of building.
- I. Customer must furnish and install conductor and conduit. Service conductors must be continuous from transformer to the splice box.
- J. KCP&L must complete connections at the transformer. Call for an appointment.
- K. Customer must furnish and install a hasp for CT cabinet and splice box.
- L. The CTs must be securely attached to either a piece of treated plywood, aluminum, or galvanized steel that is mounted to the back of the CT cabinet with the mounting studs that are permanently attached to the cabinet. Do not attach the CTs through the back of the cabinet to the wall.

- A. Locate center of meter socket 42" to 60" above grade.
- B. Use 1-1/4" rigid metallic conduit to ensure electrical bonding between CT cabinet and meter socket. Rigid metallic conduit is required between the CT cabinet and the splice box of sufficient size to accommodate service entrance cable.
- C. Ground shall not pass through CT cabinet.
- D. Splice block furnished and installed by Customer, (required only if splice box is installed).
- E. Position prefabricated conduit slip joint to compensate for soil settling. Leave sufficient slack in service conductors to allow joint to work.
- F. Use non-corrodible 2-hole conduit strap or strut.
- G. Fasten clamp system to sill plate.
- H. 1-hole clamps are not acceptable.
- J. Splice box and CT cabinet furnished and installed by Customer on outside of building. The splice box and CT cabinet must be of a reasonable size to allow for cable bending radius and workability. Dimensions are minimums only.
- K. Meter can and CTs furnished by KCP&L; installed by Customer on outside of building.
- L. For Residential service: Customer must furnish and install conductor from Customer disconnect to splice blocks in splice box and all conduit. KCP&L will furnish and install service conductor to splice box.
For Commercial service: Customer must furnish and install conduit and conductor. Service conductors must be continuous from the transformer to the splice box or service entrance (when no splice box is installed). KCP&L does not allow splicing of service entrance cables.
- M. Customer must furnish and install a hasp for CT cabinet and splice box.
- N. CTs must be securely attached to either a piece of aluminum or galvanized steel that is mounted to the back of the CT cabinet with mounting studs that are permanently attached to the cabinet. Do not attach the CT's through the back of the cabinet to the wall.
- *O. Splice Box required for Residential installation, optional for Commercial/Industrial.
- P. For Commercial Service: KCP&L must complete connections at the transformer. Call for an appointment.
- Q. Color-code wires per NEC specifications.
- R. The neutral shall pass through the CT cabinet.

**1-PHASE
METERING INSTALLATION
FOR SERVICE
GREATER THAN 400A**

DWG REV: 03/30/10 DWG: 900.1-57

**120/208V OR 277/480V
3 PHASE
METERING INSTALLATION
FOR SERVICE
GREATER THAN 200A**

DWG REV: 01/29/15 DWG: 900.1-56

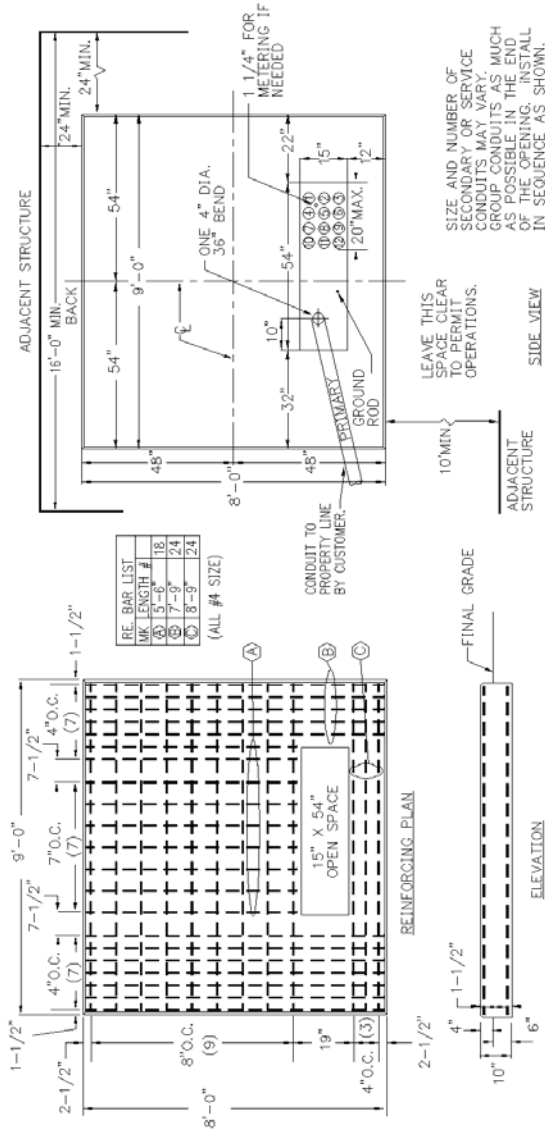

**CAST IN PLACE CONCRETE
BASE FOR 3-PHASE PADMOUNT
TRANSFORMER 750 THRU
2500kVA 12.47 OR 13.2kV**

DWG REV: 03/03/16 DWG: 700-104

NOTES:

- ALL CONCRETE SHALL BE AIR ENTRAINED AND TEST 3000 PSI (MIN.) IN 28 DAYS
- DIRECTION OF PRIMARY CONDUIT TO BE PROVIDED BY KCP&L
- A MINIMUM WIDTH OF 16" WORKING SPACE BETWEEN STRUCTURES WILL BE REQUIRED FOR TRANSFORMER INSTALLATION AND MAINTENANCE. A 24" MINIMUM DIMENSION ON ONE SIDE OF BASE REQUIRES A 60" MINIMUM ON THE OTHER SIDE, BUT EITHER SIDE MAY BE 24".
- THE SIZING OF THIS BASE IS BASED UPON AVERAGE UNDISTURBED EARTH. BACKFILL WITH COMPACT DIRT OR A83 ONLY (DO NOT USE GRAVEL) TO THE BOTTOM OF THE PAD. INSTALL CONDUITS LEVEL WITH THE TOP OF THE PAD AND COVER THE ENDS OF THE CONDUITS.
- CENTER OF BASE MUST BE WITHIN 16" OF THE EDGE OF A PAVED AREA FOR CRANE ACCESS.

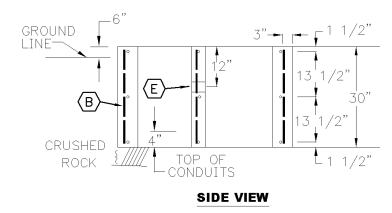
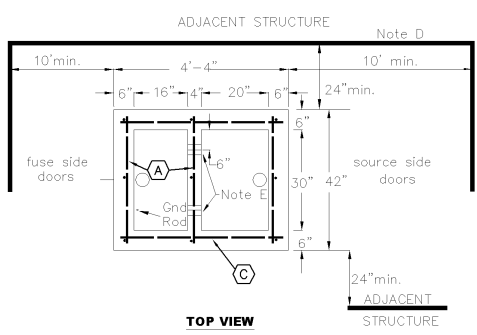
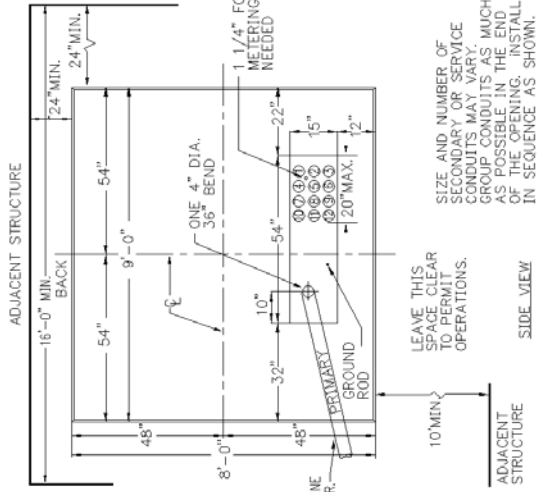

Recommended lightweight aggregate mix:

- 292# Portland Cement
- 88.7# Flyash
- 9.94 cu. ft. 3/4" x #4 Haydite Aggregate
- 828# Sand
- 6% to 8% air entrainment
- Approximately 0.71 cu. yds. required.
- Concrete to test 3000# p.s.i. minimum in 28 days.

REINFORCING BARS REQUIRED			
BAR	QUANTITY	LENGTH	SIZE
(A)	9	39"	#4
(B)	9	27"	#4
(C)	6	48"	#4

- Install 6" conduits with 36" radius bends for switch position and 4" conduits with 36" radius bends for fuse positions unless specified otherwise. Direction of conduit will vary with individual jobs.
- Grounding conductors installed in trench with primary conduit. Leave 72" extra continuous length per conductor for connection to switchgear.
- Conduits shall be installed against front and back of base and centered in cubicle.
- A minimum width of 13'-6" working space between structures will be required for switchgear installation and maintenance. A 24" minimum dimension on one side of base requires 8" minimum on the other side, but (either side may be 24").
- 3" diameter openings in two walls for lifting slings.
- Full uncut 90° conduit bends must be used, requiring conduit burial depth of 64" min. as conduit approaches base.

**CONCRETE BASE FOR PME-4
PADMOUNT SWITCHGEAR**

DWG REV: 2/6/08 DWG: 700-107