

FACILITIES FOR INTRASTATE ACCESS

RECEIVED5. SPECIAL ACCESS (Cont'd)

MAY 10 2000

5.6 Rate Regulations (Cont'd)**MISSOURI
Public Service Commission**5.6.1 Types of Rates and Charges (Cont'd)(D) Nonrecurring Charges (Cont'd)

(7) (Reserved for Future Use)

(8) Service Rearrangements

Service rearrangements are changes to existing (installed) services which may be administrative only in nature or involve an actual physical change to the service. Changes to pending orders are in 3.2.2.

Changes in the type of service will be treated as a discontinuance of the service and an installation of a new service.

Changes in the physical location of the point of termination are treated as moves which are described and charged for as in 5.6.4.

Administrative changes will be made without charge(s) to the customer. Administrative changes are as follows:

- Change in name or ownership or transfer of responsibility from one customer to another, provided there is no interruption of use or relocation of Special Access service.
- Change of customer or customer's end user premises address when the change of address is not a result of a physical relocation of equipment,
- Change in billing data (name, address, or contact name or telephone number),
- Change of customer circuit identification,
- Change of billing account number,
- Change of customer test line number,
- Change of customer or customer's end user contact name or telephone number,
- Change of agency authorization, and
- Change in jurisdiction involving no physical changes to the service.

FILED

AUG 01 2000

00 - 182
MISSOURI**Public Service Commission**

Issued: May 10, 2000

Effective: August 1, 2000

FACILITIES FOR INTRASTATE ACCESS

RECEIVED

5. SPECIAL ACCESS (Cont'd)

MAY 10 2000

5.6 Rate Regulations (Cont'd)

MISSOURI Public Service Commission

5.6.1 Types of Rates and Charges (Cont'd)

(D) Nonrecurring Charges (Cont'd)

(8) Service Rearrangements (Cont'd)

All other service rearrangements will be charged for as follows:

- If the change involves the addition of another termination to an existing two-point or multipoint service, the Initial Ordering Charge - Special Access will apply plus the Service Installation and bridging charges for each location added.
- If the change involves the addition of supplemental feature or multiplexing arrangement, the Subsequent Ordering Charge - Special Access will apply plus the installation charge associated with the supplemental feature or arrangement.
- If the change involves only changing the type of network interface, with no change in facility, the Subsequent Ordering Charge - Special Access will apply per ASR for each customer designated location requiring a network interface change. The installation charge associated with each service receiving a network interface change will also apply.
- If the change involves changing a two-wire service to a four-wire service or vice versa, the Subsequent Ordering Charge - Special Access will apply plus the Service Installation charge for each location changed.
- If the change involves only rollovers or grooming, then no charges will apply. A rollover is the retermination of a segment of a lower capacity special access service onto a higher capacity special access service. The rollover must occur in the wire center where the higher capacity service is multiplexed with no other changes to the lower capacity service being reterminated (i.e., the segment must not require rerouting to connect to the multiplexer of the higher capacity service).

Grooming is the retermination of a lower capacity special access service from one channel in a higher capacity special access service to another channel in the same higher capacity service or to another channel in another higher capacity special access service (i.e., change in connecting facility assignment) in the same wire center, with no other changes to the lower capacity service.

FILED

AUG 01 2000
00-182

MISSOURI Public Service Commission

FACILITIES FOR INTRASTATE ACCESS

RECEIVED

5. SPECIAL ACCESS (Cont'd)

MAY 10 2000

5.6 Rate Regulations (Cont'd)

**MISSOURI
Public Service Commission**

5.6.1 Types of Rates and Charges (Cont'd)

(D) Nonrecurring Charges (Cont'd)

(8) Service Rearrangements (Cont'd)

Rollover -Example 1

Current Configuration

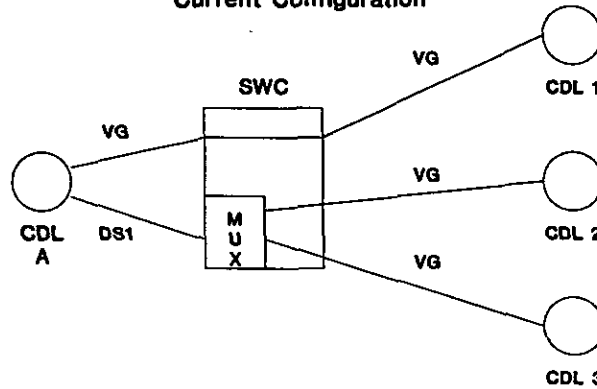

The customer requests that the voiceband circuit (VG) between CDL A and CDL 1 be "rolled over" to the DS1 serving CDL A. No NRCs apply for this request.

Rollover -Example 1

New Configuration

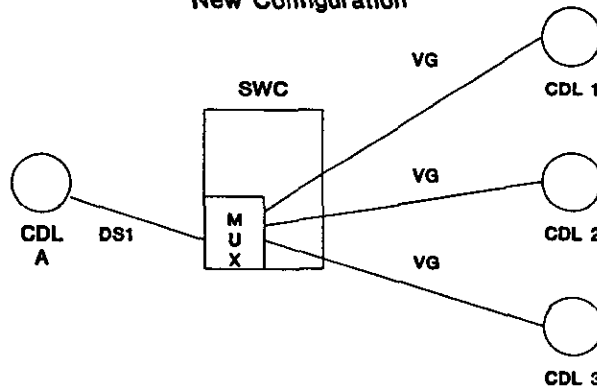

FILED

AUG 01 2000
08-182

**MISSOURI
Public Service Commission**

Issued: May 10, 2000

Effective: August 1, 2000

CANCELLED
October 19, 2009
Missouri Public
Service Commission
TN-2010-0092; YI-2010-0175

Kenneth Matzdorff
Chief Operating Officer
Kansas City, Missouri

FACILITIES FOR INTRASTATE ACCESS

RECEIVED

5. SPECIAL ACCESS (Cont'd)

MAY 10 2000

5.6 Rate Regulations (Cont'd)

5.6.1 Types of Rates and Charges (Cont'd)

MISSOURI Public Service Commission

(D) Nonrecurring Charges (Cont'd)

(8) Service Rearrangements (Cont'd)

ROLLOVER -EXAMPLE 2

Current Configuration

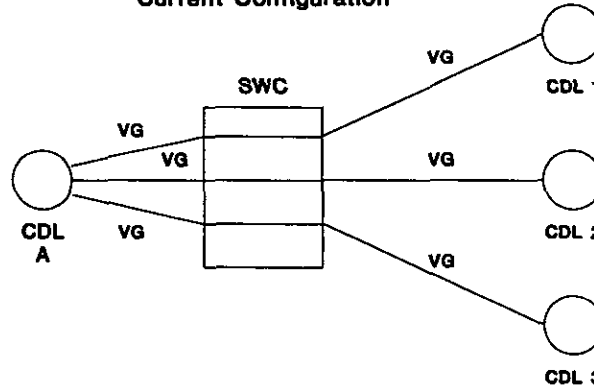

The customer requests the installation of a DS1 between the serving wire center (SWC) and CDL A and a DS1/voice multiplexer in the SWC. The customer also requests that the voiceband circuits serving CDLs 1, 2, and 3 be "rolled over" to the new DS1. All NRCs apply for the installation of the DS1 and multiplexer. No NRCs apply for the voiceband roll overs to the new high capacity circuit.

ROLLOVER -EXAMPLE 2

New Configuration

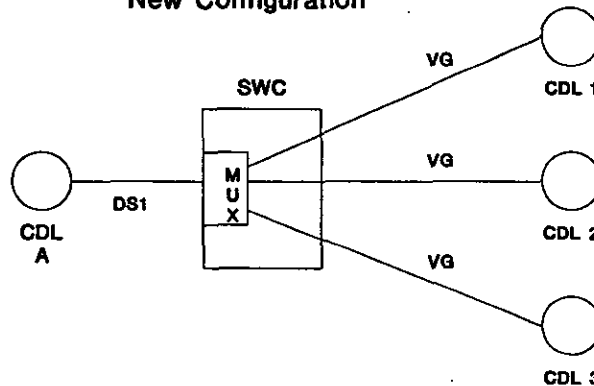

FILED

AUG 01 2000 00-182

MISSOURI Public Service Commission

Issued: May 10, 2000

Effective: August 1, 2000

CANCELLED
 October 19, 2009
 Missouri Public
 Service Commission
 TN-2010-0092; YI-2010-0175

Kenneth Matzdorff
 Chief Operating Officer
 Kansas City, Missouri

FACILITIES FOR INTRASTATE ACCESS

RECEIVED

5. SPECIAL ACCESS (Cont'd)

MAY 10 2000

5.6 Rate Regulations (Cont'd)

5.6.1 Types of Rates and Charges (Cont'd)

MISSOURI Public Service Commission

(D) Nonrecurring Charges (Cont'd)

(8) Service Rearrangements (Cont'd)

GROOMING -EXAMPLE 1

Current Configuration

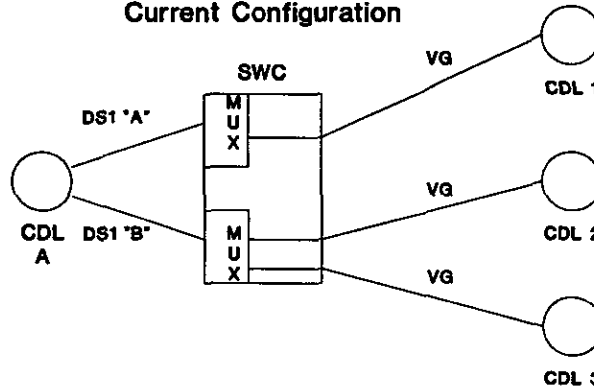

The customer requests that the voiceband (VG) circuit serving CDL 1 be moved from the DS1 "A" circuit to the DS1 "B" circuit. No NRCs apply for this request.

GROOMING -EXAMPLE 1

New Configuration

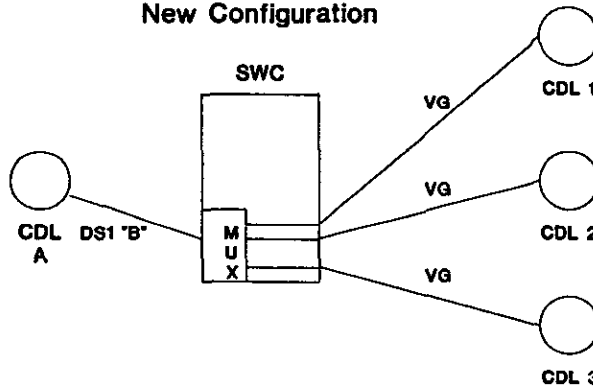

FILED

AUG 01 2000

00-182

MISSOURI Public Service Commission

Issued: May 10, 2000

Effective: August 1, 2000

CANCELLED
October 19, 2009
Missouri Public
Service Commission
TN-2010-0092; YI-2010-0175

Kenneth Matzdorff
Chief Operating Officer
Kansas City, Missouri

FACILITIES FOR INTRASTATE ACCESS

RECEIVED

5. SPECIAL ACCESS (Cont'd)

5.6 Rate Regulations (Cont'd)

MAY 10 2000

5.6.1 Types of Rates and Charges (Cont'd)

MISSOURI Public Service Commission

(D) Nonrecurring Charges (Cont'd)

(8) Service Rearrangements (Cont'd)

GROOMING -EXAMPLE 2

Current Configuration

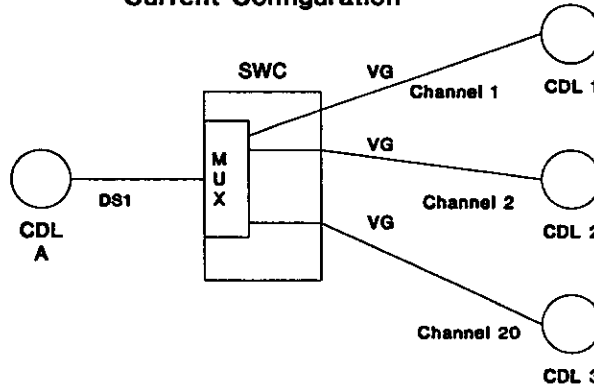

The customer requests that the voiceband circuit serving CDL 3 be moved from channel 20 in the DS1 serving CDL A to Channel 3 in the same DS1. No NRCs apply for this request.

GROOMING -EXAMPLE 2

New Configuration

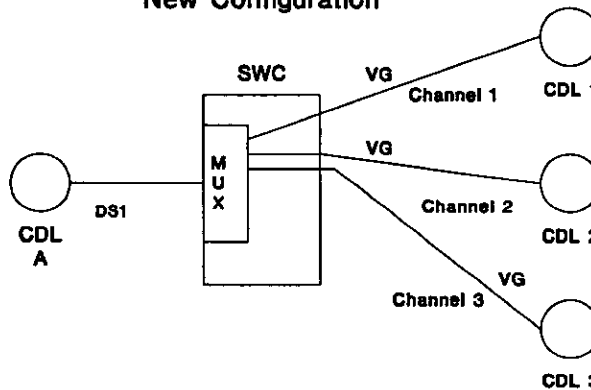

- If the change involves reterminations other than Rollovers and/or Grooming, then the Subsequent Ordering Charge - Special Access will apply plus all NRCs associated with the installation of the lower capacity service.
- In cases where multiple service rearrangements or an additional termination or a move and a service rearrangement are requested on a single ASR, the total charge will never exceed the full nonrecurring charge for the basic service.

FILED

AUG 01 2000 00-182

MISSOURI Public Service Commission

Issued: May 10, 2000

Effective: August 1, 2000

Kenneth Matzdorff Chief Operating Officer Kansas City, Missouri

CANCELLED October 19, 2009 Missouri Public Service Commission TN-2010-0092; YI-2010-0175

FACILITIES FOR INTRASTATE ACCESS

RECEIVED5. SPECIAL ACCESS (Cont'd)

MAY 10 2000

5.6 Rate Regulations (Cont'd)5.6.2 Minimum Periods

Special Access is provided for a specified minimum period and minimum period charges are described in Section 3 preceding.

5.6.3 Mileage Measurement

The mileage to be used to determine the monthly rate for the Special Transport is calculated on the airline distance between the serving wire centers involved (i.e., CDL serving wire center or Hub Wire Center or WATS Serving Office). Where the calculated miles include a fraction, the value is always rounded up to the next full mile. Where the calculated value is zero, no Special Transport mileage is charged.

When there is a Hub Wire Center involved, the Special Transport mileage will be measured from the Hub Wire Center to the serving wire centers of each of the CDLs connected to the hubbed facilities. Mileage is computed for each section and rates are applied accordingly. However, when a Special Access facility is routed through a Hub Wire Center for purposes other than customer specified such as bridging or multiplexing (e.g. the Telephone Company chooses to so route for test access purposes), rates will be applied only to the distance calculated between the wire centers serving the CDLs.

The rates for the mileage are applied per airline mile. The serving wire center V&H coordinates and the method of calculation are specified in the ECA Tariff FCC No. 4.*

5.6.4 Moves

A move involves a change in the physical location of the point of termination of Special Access. A move normally involves an interruption of Special Access for the period required to complete the move. No credit allowance will be granted for that period. Special Construction as set forth in Section 10 may also be applicable at the different CDL.

A customer may request that Special Access not be interrupted during a move. To comply with that request, it may be necessary to install a duplicate Special Access, and subsequently discontinue the existing Special Access. Charges, monthly and nonrecurring, will apply for the duplicate Special Access. A new minimum period will be established for the duplicate portion of the Special Access, depending on which end of the Special Access is moved. The customer will remain responsible for all minimum period charges associated with the corresponding portion of the disconnected Special Access.

The charge for the move depends on whether the move is within the same CDL or to a different CDL.

(A) Same CDL

When the move of a termination of FIA, as defined in Section 2.1.5, for special access is to a new point within the same CDL (same address and/or same building), the charge for the move will be the Subsequent Ordering Charge - Special Access plus one half the appropriate installation charge for the portion of the service being reterminated. There will be no change in the minimum period requirements.

* For intraLATA LEC to LEC traffic, percentages of ownership will be determined by V&H coordinates located in the Missouri PTC Plan IntraLATA Database.

Issued: May 10, 2000

Effective: August 1, 2000

CANCELLED
October 19, 2009
Missouri Public
Service Commission
TN-2010-0092; YI-2010-0175

Kenneth Matzdorff
Chief Operating Officer
Kansas City, Missouri

FILED
AUG 01 2000
MISSOURI
Public Service Commission

FACILITIES FOR INTRASTATE ACCESS

RECEIVED5. SPECIAL ACCESS (Cont'd)

MAY 10 2000

5.6 Rate Regulations (Cont'd)**MISSOURI
Public Service Commission**5.6.4 Moves (Cont'd)(B) Different CDL

- (1) When the move is to a different CDL (different address and different building), except as specified below, it will be treated as a disconnect and an installation of service. The Initial Ordering Charge - Special Access will apply plus the appropriate service installation charge for the service termination(s) affected. A new minimum period will be established for the installed Special Access Service. The customer will remain responsible for all minimum period charges associated with the disconnected Special Access Service.
- (2) When the move is to a different CDL but served by the same serving wire center, the following conditions apply:
 - A change ASR will be required.
 - Subsequent Ordering Charge - Special Access will apply plus the appropriate service installation charge for the service termination(s) affected.

5.6.5 Rates and Charges on an Individual Case Basis

- (A) The monthly rates and nonrecurring charges for the following service offerings will be developed on an Individual Case Basis:
 - Full-time Videoband - Type I Facilities
 - High Capacity Digital DS1C (3.152 Mbps) Special Access Lines
 - High Capacity Digital DS3 (44.736 Mbps) Facilities
 - High Capacity Digital DS3C (89.472 Mbps) Facilities
- (B) The monthly rates and nonrecurring charges for the following Multiplexing Arrangements will be developed on an Individual Case Basis:

Group to Voice
 Supergroup to Group
 Mastergroup to Supergroup
 DS3 to DS1
 DS3C to DS1
 Group to DS1

FILED

AUG 01 2000

00-182

**MISSOURI
Public Service Commission**

Issued: May 10, 2000

Effective: August 1, 2000

CANCELLED
 October 19, 2009
 Missouri Public
 Service Commission
 TN-2010-0092; YI-2010-0175

Kenneth Matzdorff
 Chief Operating Officer
 Kansas City, Missouri

FACILITIES FOR INTRASTATE ACCESS

RECEIVED5. SPECIAL ACCESS (Cont'd)

MAY 10 2000

5.6 Rate Regulations (Cont'd)5.6.6 Hub Wire Centers**MISSOURI
Public Service Commission**

A Hub Wire Center is a Telephone Company designated serving wire center at which bridging or multiplexing arrangements are provided. Bridging is used to connect three or more CDLs in a multipoint arrangement. The multiplexing arrangements channelize analog or digital facilities to individual services requiring a lower capacity or bandwidth.

Although Hub Wire Centers are defined as serving wire centers at which bridging or multiplexing arrangements are performed, they are not limited to providing these functions and may provide any other types of Special Access services offered in this tariff. For example, the Telephone Company will designate certain Hub Wire Centers for Program Audio service offerings.

The Telephone Company will designate the Hub Wire Center locations. Different locations may be designated as Hub Wire Centers for different functions, such as bridging or multiplexing arrangements, for different facility capacities (e.g., multiplexing from digital to digital may occur at one wire center while multiplexing from digital to analog may occur at a different wire center). The location of Hub Wire Centers and the types of hubbing functions offered at that location are identified in the ECA Tariff FCC No. 4.

Some of the types of multiplexing provided include the following:

- from higher to lower bit rate,
- from higher to lower bandwidth,
- from digital to voice grade service.

The transmission performance for the end to end Special Access provided from CDLs will be that of the lower capacity or bit rate. For example, when a DS1 Special Access is multiplexed to voice frequency circuits, the transmission performance will be Voiceband, not High Capacity.

The Telephone Company will commence billing the monthly rate for the Special Access Line and Special Transport for the High Capacity facility to the Hub Wire Center as of the service date, even though individual services utilizing those facilities may not be installed until a later date. If the customer has designated the type of multiplexing to be provided with the High Capacity facility, the nonrecurring charge for the Multiplexing Arrangement will be billed to the same customer at that same time, and the billing for the monthly rate will begin.

Individual Special Access rates (by Special Access type) will apply for the Special Access Line and additional Special Transport facilities (if required) for each channelized Special Access. These will be billed to the customer specified on the ASR as each individual Special Access is installed.

A customer may order full-time and/or part-time Program Audio Services between two CDLs, or between a CDL and a Hub Wire Center, and will be billed accordingly at the rates set forth in Sections 5.7.3(A), 5.7.3(B), 5.7.3(C) and 5.7.3(D) following.

FILEDAUG 01 2000
00 - 182**MISSOURI
Public Service Commission**

Issued: May 10, 2000

Effective: August 1, 2000

FACILITIES FOR INTRASTATE ACCESS

RECEIVED5. SPECIAL ACCESS (Cont'd)

MAY 10 2000

5.6 Rate Regulations (Cont'd)5.6.6 Hub Wire Centers (Cont'd)**MISSOURI
Public Service Commission**

At the request of the customer, the full-time and/or part-time services provided to a Hub Wire Center may be connected together in the following configurations: full-time to full-time, full-time to part-time, or part-time to part-time.

The rates that apply for Program Audio Services between each CDL and the Hub Wire Center are Special Transport, if applicable, and Special Access Line. In addition, rates for Supplemental Features and Inside Wiring may be applicable.

5.6.7 Shared Use Analog and Digital High Capacity Services

- (A) Shared use occurs when Special Access Service and Switched Access Service are provided over the same digital high capacity facility through a common interface. Shared use refers to the service arrangement where the customer orders a digital high capacity facility between a CDL and the Hub Wire Center where the Telephone Company performs multiplexing functions and the customer then orders the derived channels as Special and Switched Access services.

The shared use facility will be ordered, provided and rated as Special Access Service (i.e., Special Access Line, Special Transport and Special Transport Termination, as appropriate, and Multiplexer). The nonrecurring charge that applies when the shared use facility is installed will be the nonrecurring charge associated with the appropriate High Capacity Special Access Line. When the customer orders derived channels as Switched or Special, the nonrecurring charges applicable to those individual services will be assessed. The rate elements associated with the high capacity facility and multiplexer will be billed to one customer. The rate elements associated with each individual channel may be billed to a different customer.

Rating as Special Access will continue until such time as a portion of the available capacity for providing Special Access Service is used to provide Switched Access Service. As each individual channel is activated for Switched Access Service, the Special Access Line, Special Transport and Special Transport Termination as appropriate, and Multiplexer, will be reduced based on their rates and capacity, accordingly, (i.e., 1/24th for a DS1 Service). Switched Access Minimum Capacity Requirements as set forth in 3.5 preceding will not apply. The customer must submit an ASR for each individual Switched or Special Access Service utilizing the shared use facility and specify the channel assignment (CFA) for each service. The customer for the individual Switched Access and Special Access Services may be different.

- (B) Switched Access Service rates and charges as set forth in Section 4 preceding will apply for each derived channel of the shared use facility that is used to provide Switched Access Service. Where Special Access Service is provided utilizing a channel of the shared use facility to the hub, High Capacity Special Access rates will apply for the facility to the hub as set forth preceding and individual service rates will apply from the hub to the terminating customer designated location. The rates that will apply to the portion from the hub to the terminating customer designated location will be dependent on the specific type of Special Access Service that is provided (i.e., Voice Grade). The applicable rates will include a Special Access Line and Special Transport, if applicable. Rates for optional features and functions, if any, associated with the service will also apply.

5.6.8 (Reserved for Future Use)

FILED

Issued: May 10, 2000

Effective: August 1, 2000

AUG 01 2000
00-182
**MISSOURI
Public Service Commission**

FACILITIES FOR INTRASTATE ACCESS

RECEIVED5. SPECIAL ACCESS (Cont'd)

MAY 10 2000

5.6 Rate Regulations (Cont'd)5.6.9 Special Access Surcharge (USOC - S25)**MISSOURI
Public Service Commission**

Pending the development of techniques to accurately measure usage of local facilities which are interconnected by users by means of intrastate or foreign telecommunications, a surcharge of \$25.00 per service per month will be assessed to a two point Special Access Service, and to each additional Special Access Line when the service is configured as multipoint. The Special Access Surcharge will also be assessed upon Wideband Analog, High Capacity Digital and FT1 Services on a voiceband equivalent basis. The voiceband equivalency for these type services is as follows:

- High Capacity DS1 equates to 24 Voiceband Facilities
- High Capacity DS1C equates to 48 Voiceband Facilities
- High Capacity DS3 equates to 672 Voiceband Facilities
- High Capacity DS3C equates to 1344 Voiceband Facilities
- Wideband Group equates to 12 Voiceband Facilities
- Wideband Supergroup equates to 60 Voiceband Facilities
- Wideband Mastergroup equates to 600 Voiceband Facilities
- Each 56 Kbps or 64 Kbps Channel in a FT1 Service equates to one Voiceband Facility.

The Special Access Service will be exempted from the monthly surcharge if the customer provides the Telephone Company written certification that the termination is one of the following: (USOC - S25EX)

- (1) The open end termination (dial tone end) of a Foreign Central Office Line, Common Control Switching Arrangement (or equivalent) or Off Network Access Line (ONAL).
- (2) Any termination of an analog circuit used for radio or television program transmission.
- (3) Any termination of a line used for telex service.
- (4) Any termination of a line by nature of its operating characteristics and nature of connection could not make use of common lines.
- (5) Any line termination, other than (1) through (4) preceding, which is subject to the following charges: (a) Carrier Common Line, (b) End Office Switching, and (c) Switched Transport.
- (6) A termination that the customer certifies to the Telephone Company is not connected to a PBX or other device capable of interconnecting the Special Access Service to the local network. If the PBX or other device has been configured either through software programming or physical restrictions not to access the local network, then the customer may file the surcharge exemption for the Special Access Service terminating on this equipment.

FILEDAUG 01 2000
00-182**MISSOURI
Public Service Commission**

Issued: May 10, 2000

Effective: August 1, 2000

FACILITIES FOR INTRASTATE ACCESS

RECEIVED5. SPECIAL ACCESS (Cont'd)

MAY 10 2000

5.6 Rate Regulations (Cont'd)5.6.9 Special Access Surcharge (Cont'd)**MISSOURI
Public Service Commission**

In order for the Telephone Company to determine the application of the surcharge with respect to specific services, the customer must report the intended use of all services when placing ASRs for Special Access Service. In addition, when ordering High Capacity Analog or Digital services, the customer must report the use for each voice equivalent circuit of the high capacity service. When any circuit is reported wholly used in any manner described in (1) through (6) preceding, the surcharge will not apply. If the intended use is not reported, the surcharge will apply.

If, at any time after the installation of a service which is subject to the surcharge, the customer reports that the service is being used consistently with any exception listed above, the Telephone Company will credit the customer for the surcharge. Credit will not be given beyond the receipt date of the certification for exemption.

5.6.10 Message Station Equipment Recovery Charge (USOC - UTM)

Message Station Equipment Recovery Charge is a charge to recover that portion of message station equipment which is assigned to Special Access Service. Since there is zero cost assigned to Message Station Equipment Recovery in Special Access the charge is \$.00.

5.6.11 (Reserved for Future Use)

FILED

AUG 01 2000

00 - 182

**MISSOURI
Public Service Commission**

Issued: May 10, 2000

Effective: August 1, 2000

FACILITIES FOR INTRASTATE ACCESS

RECEIVED5. SPECIAL ACCESS (Cont'd)

MAY 10 2000

5.6 Rate Regulations (Cont'd)**MISSOURI
Public Service Commission**5.6.12 Optional Payment Plan (OPP)(A) General

- (1) The terms and conditions specified herein are applicable to FT1 service. Additional terms and conditions for FT1 OPP are set forth in 5.6.12(I).
- (2) Only the Special Access Line (SAL) rate element is available under an OPP. All other associated rate elements or additional features are available at the standard month-to-month tariffed rates and regulations.
- (3) FT1 OPP SAL rates will not be greater than standard month-to-month SAL rates.
- (4) Three year and five year OPP rates will be equal to or less than the one year OPP rates. Decreases to the one year OPP will flow through to the three year and five year OPP.
- (5) Payment periods of one year, three year, and five year are available to all customers at the applicable rates set forth in 5.7.9(B) regardless of when they subscribe to an OPP arrangement.
- (6) The customer must designate on the ASR the payment period for the OPP.
- (7) Inside moves, provided in accordance with 5.6.4, will not incur termination liability charges.
- (8) Outside moves provided in accordance with 5.6.4(B) will allow the customer to retain the same OPP payment period. Any other move will be treated as a disconnect of the service and termination liability charges will apply.

(B) Changes in Length of OPP Period

Prior to the completion of the selected OPP period, the customer may elect to convert to a new OPP period of the same or different length, subject to the following conditions:

- No credit toward the new payment period will be given for payments made under the original OPP arrangement.
- Nonrecurring charges will not be reapplied for existing service(s).
- If the new OPP period is shorter in length than the time remaining under the existing OPP, the change to the new OPP period constitutes a disconnect of the existing OPP service and termination liability charges apply.

FILED

AUG 01 2000

00 - 182

**MISSOURI
Public Service Commission**

Issued: May 10, 2000

Effective: August 1, 2000

FACILITIES FOR INTRASTATE ACCESS

RECEIVED5. SPECIAL ACCESS (Cont'd)

MAY 10 2000

5.6 Rate Regulations (Cont'd)**MISSOURI
Public Service Commission**5.6.12 Optional Payment Plan (OPP) (Cont'd)(C) Renewal Options

- (1) At the expiration of an OPP period, the Telephone company will automatically renew the service at the same OPP period unless the customer chooses to convert to a different OPP period, convert to month-to-month rates or discontinue service.
- (2) Conversion to a different OPP period will require the customer to submit a change order ASR. Conversion to a different OPP period will be allowed without application of any nonrecurring or ordering charges.
- (3) Conversion to month-to-month rates will be treated as a disconnect of service and establishment of new service. If no other changes are ordered, no NRCs will apply.

(D) Notification of Discontinuance

An ASR for discontinuance of an OPP arrangement must be received by the Telephone Company at least thirty (30) days prior to actual disconnect of service. Monthly charges will apply for a period of thirty (30) days from the date the Telephone Company receives disconnect notification or until the requested disconnect date, whichever period is longer.

(E) Upgrade to Higher Speed Service

Customers may elect to upgrade service(s) to a higher speed during an OPP period, subject to the following conditions:

- The upgraded service will be subject to all appropriate nonrecurring charges.
- Termination liability charges will not apply as long as the upgraded service remains connected at the same point of termination(s) or meets the requirements set forth in 5.6.4(B).
- If the upgrade involves establishing a multiplexing arrangement, termination liability charges will not apply if the hub wire center is the same one associated with the customer designated location.

(F) Termination Liability

When an OPP service is discontinued prior to the end of the period, termination liability charges, as set forth below, will apply based on the remainder of the OPP period in effect at the time of disconnect.

One Year OPP - 50% of any remaining portion of the first year's recurring charges.

Three Year OPP - 50% of any remaining portion of the first year's recurring charges. In addition, for any remaining portion of the second and third years, the customer will be liable for 10% of the total monthly recurring charges in that time period.

Five Year OPP - 50% of any remaining portion of the first year's recurring charges. In addition, for any remaining portion of the second through fifth years, the customer will be liable for 20% of the total monthly recurring charges in that time period.

FILED

Issued: May 10, 2000

Effective: August 1, 2000

CANCELLED
October 19, 2009
Missouri Public
Service Commission
TN-2010-0092; YI-2010-0175

Kenneth Matzdorff
Chief Operating Officer
Kansas City, Missouri

AUG 01 2000
00-182
MISSOURI
Public Service Commission

FACILITIES FOR INTRASTATE ACCESS

RECEIVED

5. SPECIAL ACCESS (Cont'd)

MAY 10 2000

5.6 Rate Regulations (Cont'd)

5.6.12 Optional Payment Plan (OPP) (Cont'd)

MISSOURI
Public Service Commission

(F) Termination Liability

Customer liability will be calculated as previously stated, but will be limited to:

The dollar difference between 1) the amount the customer has already paid and, 2) any additional charges that the customer would have paid for service if the customer had taken a shorter term offering corresponding to the term actually used.

For example, if a customer with a five year OPP discontinues service six months after the end of the third year, the customer liability will not exceed:

[(Three year monthly rate - Five year monthly rate) x 42 months]

(G) Termination Without Liability

During an OPP period, should the currently effective rate for a customer's service increase, the customer may, at their option, terminate the OPP arrangement without penalty or liability.

(H) (Reserved for Future Use)

FILED

AUG 01 2000
00 - 182

MISSOURI
Public Service Commission

Issued: May 10, 2000

Effective: August 1, 2000

CANCELLED
October 19, 2009
Missouri Public
Service Commission
TN-2010-0092; YI-2010-0175

Kenneth Matzdorff
Chief Operating Officer
Kansas City, Missouri

FACILITIES FOR INTRASTATE ACCESS

RECEIVED

5. SPECIAL ACCESS (Cont'd)

MAY 10 2000

5.6 Rate Regulations (Cont'd)

5.6.12 Optional Payment Plan (OPP) (Cont'd)

MISSOURI Public Service Commission

(I) OPP for FT1 Service

A customer may change the number of channels of an N x 56 Kbps or N x 64 Kbps service to another higher value of N (where N = 2, 4, or 6), subject to the following rate applications:

- The changed service will be subject to all appropriate nonrecurring charges.
- Termination liability charges will not apply as long as the changed service remains connected at the same point of termination(s) or meets the requirements of 5.6.4(B).
- If the change involves establishing a multiplexing arrangement, termination liability charges will not apply if the hub wire center is the same one associated with the customer designated location.

5.6.13 (Reserved for Future Use)

5.6.14 (Reserved for Future Use)

5.6.15 (Reserved for Future Use)

FILED

AUG 01 2000

00 - 182

MISSOURI Public Service Commission

Issued: May 10, 2000

Effective: August 1, 2000

CANCELLED
October 19, 2009
Missouri Public
Service Commission
TN-2010-0092; YI-2010-0175

Kenneth Matzdorff
Chief Operating Officer
Kansas City, Missouri

FACILITIES FOR INTRASTATE ACCESS

RECEIVED

5. SPECIAL ACCESS (Cont'd)

MAY 10 2000

5.6 Rate Regulations (Cont'd)

MISSOURI Public Service Commission

5.6.16 SPECTRALAN Special Transport

(A) Description

SPECTRALAN Special Transport (SPECTRALAN) provides DS1 transport between two or more serving wire centers located on Telephone Company fiber optic facilities. SPECTRALAN transport is provided at a flat-rate per month charge per DS1 transport facility, regardless of the number of miles the circuit is routed on the designated SPECTRALAN fiber facilities.

SPECTRALAN is only available when purchased with a SPECTRA access service.

(B) Conversion of Existing DS1 Transport

Current DS1 transport can be replaced by SPECTRALAN. Customers must submit an ASR to convert the existing DS1 transport to SPECTRALAN.

(C) (Reserved for Future Use)

(D) Discontinuance of Service

If a DS1 SAL is discontinued, DS1 transport for the SPECTRALAN transport portion of the circuit is also discontinued.

SPECTRALAN transport may be converted to standard special access transport rates (i.e., per airline mile) at any time at no charge.

(E) Continuation of Service Off the Ring

SPECTRALAN DS1 circuits can be routed any distance on a SPECTRALAN. When the DS1 circuit leaves the SPECTRALAN for continuation on the network, normal tariff rates will be assessed for the portion of the route not on the SPECTRALAN.

(F) (Reserved for Future Use)

(G) (Reserved for Future Use)

(H) Service Availability

SPECTRALAN DS1 transport is available to all DS1 customers in the Telephone Company serving areas where facilities are available.

FILED

AUG 01 2000

00-182 MISSOURI

Public Service Commission

Issued: May 10, 2000

Effective: August 1, 2000

FACILITIES FOR INTRASTATE ACCESS

RECEIVED

5. SPECIAL ACCESS (Cont'd)

5.7 Rates and Charges

5.7.1 Nonrecurring Charges

Special Access Ordering Charges

	<u>Initial Order</u>	<u>Subsequent Order</u>	<u>Design Change</u>
(USOC)	(SESCL)	(SESBX)	<u>Per ASR/Per Occurrence</u> (H28)
	\$116.24	\$85.85	\$27.00

MAY 10 2000

MISSOURI
Public Service Commission

FILED

AUG 01 2000

00 - 182
MISSOURI

Public Service Commission

Issued: May 10, 2000

Effective: August 1, 2000

CANCELLED
October 19, 2009
Missouri Public
Service Commission
TN-2010-0092; YI-2010-0175

Kenneth Matzdorff
Chief Operating Officer
Kansas City, Missouri

FACILITIES FOR INTRASTATE ACCESS

5. SPECIAL ACCESS (Cont'd)

5.7 Rates and Charges (Cont'd)

5.7.2 Voiceband Facilities

(A) Standard Arrangements

<u>Special Transport</u> <u>(Per Airline Mile)</u> <u>Monthly Rate</u> (USOC) (1LFSX)	<u>Special Access Line</u>		
	<u>Nonrecurring</u> <u>Charge</u> (EUC2X) (EUC4X)	<u>Two-Wire</u> <u>Monthly Rate</u> (EUC2X)	<u>Four-Wire</u> <u>Monthly Rate</u> (EUC4X)
\$ 5.71 (I)	\$210.00 (I)	\$34.72 (I)	\$66.15 (I)

(B) Optional Arrangements

<u>Multipoint Data Bridging (Per Port)</u> <u>Nonrecurring</u> <u>Charge</u> (USOC)	<u>Supplemental Features</u> <u>Voice Conference Bridging (Per Port)</u>		
	<u>Monthly</u> <u>Rate</u> (B5NDJ)	<u>Nonrecurring</u> <u>Charge</u>	<u>Monthly</u> <u>Rate</u> (B5NVJ)
\$ 0.00	\$ 8.00	\$ 0.00	\$ 8.00

<u>Common Equipment</u> <u>Nonrecurring</u> <u>Charge</u> (USOC)	<u>Supplemental Features</u> <u>Alarm Distribution Bridging</u> <u>Per Two-Wire Port</u>		
	<u>Monthly</u> <u>Rate</u> (BCNTA)	<u>Nonrecurring</u> <u>Charge</u>	<u>Monthly</u> <u>Rate</u> (CNLRX)
\$ 0.00	\$30.00	\$ 0.00	\$ 2.00

Issued: July 15, 2008

Effective: September 1, 2008

Chantel Mosby
Director, Tariffs and Compliance
Monroe, Louisiana

FACILITIES FOR INTRASTATE ACCESS

5. SPECIAL ACCESS (Cont'd)

5.7 Rates and Charges (Cont'd)

5.7.2 Voiceband Facilities

(A) Standard Arrangements

	<u>Special Transport</u>	<u>Special Access Line</u>		
	<u>(Per Airline Mile)</u>	<u>Nonrecurring</u>	<u>Two-Wire</u>	<u>Four-Wire</u>
(USOC)	<u>Monthly Rate</u>	<u>Charge</u>	<u>Monthly Rate</u>	<u>Monthly Rate</u>
	(1LFSX)	(EUC2X)	(EUC2X)	(EUC4X)
		(EUC4X)		
	\$ 5.44 (I)	\$200.00	\$33.07 (I)	\$63.00 (I)

(B) Optional Arrangements

	<u>Supplemental Features</u>			
	<u>Multipoint Data Bridging (Per Port)</u>	<u>Voice Conference Bridging (Per Port)</u>		
(USOC)	<u>Nonrecurring</u>	<u>Monthly</u>	<u>Nonrecurring</u>	<u>Monthly</u>
	<u>Charge</u>	<u>Rate</u>	<u>Charge</u>	<u>Rate</u>
	(B5NDJ)		(B5NVJ)	
	\$ 0.00	\$ 8.00	\$ 0.00	\$ 8.00

	<u>Supplemental Features</u>			
	<u>Alarm Distribution Bridging</u>		<u>Per Two-Wire Port</u>	
(USOC)	<u>Common Equipment</u>		<u>Nonrecurring</u>	<u>Monthly</u>
	<u>Charge</u>	<u>Monthly</u>	<u>Charge</u>	<u>Rate</u>
	(BCNTA)	<u>Rate</u>	(CNLRX)	
	\$ 0.00	\$30.00	\$ 0.00	\$ 2.00

Issued: July 16, 2007

Effective: September 1, 2007

Chantel Mosby
Manager, Tariffs and Compliance
Monroe, Louisiana

CANCELLED
September 1, 2008
Missouri Public
Service Commission

FILED
Missouri Public
Service Commission

FACILITIES FOR INTRASTATE ACCESS

5. SPECIAL ACCESS (Cont'd)

5.7 Rates and Charges (Cont'd)

5.7.2 Voiceband Facilities

(A) Standard Arrangements

<u>Special Transport</u> <u>(Per Airline Mile)</u> <u>Monthly Rate</u> (USOC) (1LFSX)	<u>Special Access Line</u>		
	<u>Nonrecurring</u> <u>Charge</u> (EUC2X) (EUC4X)	<u>Two-Wire</u> <u>Monthly Rate</u> (EUC2X)	<u>Four-Wire</u> <u>Monthly Rate</u> (EUC4X)
\$ 5.19	\$200.00	\$31.50 (I)	\$60.00 (I)

(B) Optional Arrangements

<u>Multipoint Data Bridging (Per Port)</u> <u>Nonrecurring</u> <u>Charge</u> (USOC)	<u>Supplemental Features</u> <u>Voice Conference Bridging (Per Port)</u>		
	<u>Monthly</u> <u>Rate</u> (B5NDJ)	<u>Nonrecurring</u> <u>Charge</u>	<u>Monthly</u> <u>Rate</u> (B5NVJ)
\$ 0.00	\$ 8.00	\$ 0.00	\$ 8.00

<u>Common Equipment</u> <u>Nonrecurring</u> <u>Charge</u> (USOC)	<u>Supplemental Features</u> <u>Alarm Distribution Bridging</u> <u>Per Two-Wire Port</u>		
	<u>Monthly</u> <u>Rate</u> (BCNTA)	<u>Nonrecurring</u> <u>Charge</u>	<u>Monthly</u> <u>Rate</u> (CNLRX)
\$ 0.00	\$30.00	\$ 0.00	\$ 2.00

Issued: August 1, 2005

Effective: September 1, 2005

Chantel Mosby
Manager, Tariffs and Compliance
Monroe, Louisiana

FILED

MO PSC

CANCELLED
Sept. 1, 2007
Missouri Public
Service Commission

FACILITIES FOR INTRASTATE ACCESS

RECEIVED

5. SPECIAL ACCESS (Cont'd)

MAY 10 2000

5.7 Rates and Charges (Cont'd)

**MISSOURI
Public Service Commission**

5.7.2 Voiceband Facilities

(A) Standard Arrangements

(USOC)	<u>Special Transport (Per Airline Mile)</u> <u>Monthly Rate</u> (1LFSX)	<u>Special Access Line</u>		
		<u>Nonrecurring Charge</u> (EUC2X) (EUC4X)	<u>Two-Wire</u>	<u>Four-Wire</u>
			<u>Monthly Rate</u> (EUC2X)	<u>Monthly Rate</u> (EUC4X)
	\$ 5.19	\$200.00	\$30.00	\$58.20

(B) Optional Arrangements

<u>Port)</u> (USOC)	<u>Supplemental Features</u>			
	<u>Multipoint Data Bridging (Per Port)</u>		<u>Voice Conference Bridging (Per</u>	
	<u>Nonrecurring Charge</u>	<u>Monthly Rate</u> (B5NDJ)	<u>Nonrecurring Charge</u>	<u>Monthly Rate</u> (B5NVJ)
	\$ 0.00 (R)	\$ 8.00	\$ 0.00	\$ 8.00

(USOC)	<u>Supplemental Features</u>			
	<u>Alarm Distribution Bridging</u>		<u>Per Two-Wire Port</u>	
	<u>Common Equipment Nonrecurring Charge</u>	<u>Monthly Rate</u> (BCNTA)	<u>Nonrecurring Charge</u>	<u>Monthly Rate</u> (CNLRX)
	\$ 0.00	\$30.00	\$ 0.00	\$ 2.00

CANCELLED

SEP 01 2005
By *ISTRSDOS*
Public Service Commission
MISSOURI

FILED

AUG 01 2000
00 - 182
MISSOURI
Public Service Commission

FACILITIES FOR INTRASTATE ACCESS

RECEIVED

MAY 10 2000

5. SPECIAL ACCESS (Cont'd)

5.7 Rates and Charges (Cont'd)

5.7.2 Voiceband Facilities (Cont'd)

**MISSOURI
Public Service Commission**

(B) Optional Arrangements (Cont'd)

		<u>Supplemental Features</u>			
		<u>Conditioning Arrangements - Data</u>			
		<u>Type C</u>		<u>Type DA</u>	
(USOC)	<u>Nonrecurring Charge</u>	<u>Monthly Rate</u> (X1CPT)	<u>Nonrecurring Charge</u>	<u>Monthly Rate</u> (XDCPT)	
	\$ 0.00	\$ 11.86	\$ 0.00	\$ 2.00	

		<u>Supplemental Features</u>	
		<u>Conditioning Arrangements - Data</u>	
		<u>Type C - Improved</u>	
(USOC)	<u>Nonrecurring Charge</u> (UHV, UHW, XCECM\UHV, UHW, XCECM)	<u>Monthly Rate</u>	
	\$ 3.00	\$ 30.00	

		<u>Supplemental Features</u>			
		<u>Signaling Arrangement</u>			
		<u>Loop Signaling Range Extension, per SAL</u>		<u>Loop or E&M to SF, per SAL</u>	
(USOC)	<u>Nonrecurring Charge</u>	<u>Monthly Rate</u> (OSA)	<u>Nonrecurring Charge</u>	<u>Monthly Rate</u> (OSB)	
	\$ 0.00	\$ 10.00	\$ 0.00	\$ 16.00	

		<u>Supplemental Features</u>			
		<u>Signaling Arrangement</u>			
		<u>E&M to DX, per SAL</u>		<u>E&M to Loop, per SAL</u>	
(USOC)	<u>Nonrecurring Charge</u>	<u>Monthly Rate</u> (OSC)	<u>Nonrecurring Charge</u>	<u>Monthly Rate</u> (OSD)	
	\$ 0.00	\$ 14.00	\$ 0.00	\$ 12.00	

FILED

AUG 01 2000
00-182

**MISSOURI
Public Service Commission**

Issued: May 10, 2000

Effective: August 1, 2000

CANCELLED
October 19, 2009
Missouri Public
Service Commission
TN-2010-0092; YI-2010-0175

Kenneth Matzdorff
Chief Operating Officer
Kansas City, Missouri

FACILITIES FOR INTRASTATE ACCESS

RECEIVED

MAY 10 2000

**MISSOURI
Public Service Commission**

5. SPECIAL ACCESS (Cont'd)

5.7 Rates and Charges (Cont'd)

5.7.2 Voiceband Facilities (Cont'd)

(B) Optional Arrangements (Cont'd)

(USOC)	<u>Supplemental Features</u>			
	<u>Signaling Arrangement</u>			
	<u>Loop or E&M to PCM, per SAL</u>		<u>Automatic Ringdown, per SAL</u>	
	<u>Nonrecurring</u>	<u>Monthly</u>	<u>Nonrecurring</u>	<u>Monthly</u>
	<u>Charge</u>	<u>Rate</u>	<u>Charge</u>	<u>Rate</u>
		<u>(OSN)</u>		<u>(XSSLR)</u>
	\$ 0.00	\$ 4.00	\$ 0.00	\$16.78

(USOC)	<u>Supplemental Features</u>			
	<u>Echo Control</u>			
	<u>Echo Suppression, per circuit *</u>		<u>Echo Cancellor, per circuit</u>	
	<u>Nonrecurring</u>	<u>Monthly</u>	<u>Nonrecurring</u>	<u>Monthly</u>
	<u>Charge</u>	<u>Rate</u>	<u>Charge</u>	<u>Rate</u>
		<u>(OE1)</u>		<u>(ORJ)</u>
	\$ 0.00	\$ 30.00	\$ 0.00	\$ 85.00

(USOC)	<u>Supplemental Features</u>	
	<u>Voiceband Facility Switching Arrangement</u>	
	<u>Nonrecurring</u>	<u>Monthly</u>
	<u>Charge</u>	<u>Rate</u>
		<u>(UST)</u>
	\$ 0.00	\$ 7.00

FILED

AUG 01 2000
00 - 182

**MISSOURI
Public Service Commission**

* Obsolete and is applicable only to existing customers at existing locations.

Issued: May 10, 2000

Effective: August 1, 2000

FACILITIES FOR INTRASTATE ACCESS

RECEIVED

5. SPECIAL ACCESS (Cont'd)

MAY 10 2000

5.7 Rates and Charges (Cont'd)

**MISSOURI
Public Service Commission**

5.7.2 Voiceband Facilities (Cont'd)

(B) Optional Arrangements (Cont'd)

<u>SAL</u>	<u>Supplemental Features</u>			
	<u>Improved Return Loss, Per SAL</u>		<u>Improved Termination Option, Per</u>	
(USOC)	<u>Nonrecurring Charge</u>	<u>Monthly Rate (1RL)</u>	<u>Nonrecurring Charge</u>	<u>Monthly Rate (X4T)</u>
	\$ 0.00	\$ 3.75	\$ 0.00	\$ 10.00

<u>SAL</u>	<u>Supplemental Features</u>	
	<u>Improved Equal Level Echo Path Loss, Per SAL</u>	
(USOC)	<u>Nonrecurring Charge</u>	<u>Monthly Rate (ORP)</u>
	\$ 0.00	\$ 3.75

FILED

AUG 01 2000

00-182

**MISSOURI
Public Service Commission**

Issued: May 10, 2000

Effective: August 1, 2000

CANCELLED
October 19, 2009
Missouri Public
Service Commission
TN-2010-0092; YI-2010-0175

Kenneth Matzdorff
Chief Operating Officer
Kansas City, Missouri

FACILITIES FOR INTRASTATE ACCESS

RECEIVED

5. SPECIAL ACCESS (Cont'd)

MAY 10 2000

5.7 Rates and Charges (Cont'd)

(Reserved for Future Use)

**MISSOURI
Public Service Commission**

FILED

AUG 01 2000

00 - 182

**MISSOURI
Public Service Commission**

Issued: May 10, 2000

Effective: August 1, 2000

CANCELLED
October 19, 2009
Missouri Public
Service Commission
TN-2010-0092; YI-2010-0175

Kenneth Matzdorff
Chief Operating Officer
Kansas City, Missouri

FACILITIES FOR INTRASTATE ACCESS

RECEIVED

5. SPECIAL ACCESS (Cont'd)

MAY 10 2000

5.7 Rates and Charges (Cont'd)

(Reserved for Future Use)

**MISSOURI
Public Service Commission**

FILED

AUG 01 2000
00 - 182

**MISSOURI
Public Service Commission**

Issued: May 10, 2000

Effective: August 1, 2000

CANCELLED
October 19, 2009
Missouri Public
Service Commission
TN-2010-0092; YI-2010-0175

Kenneth Matzdorff
Chief Operating Officer
Kansas City, Missouri

FACILITIES FOR INTRASTATE ACCESS5. SPECIAL ACCESS (Cont'd)5.7 Rates and Charges (Cont'd)5.7.3 Program Audio Facilities(A) Standard Arrangements - (200-3500 Hz)

<u>Special Transport</u> <u>(Per Airline Mile)</u>		<u>Special Access Line</u>		
<u>Monthly Rate</u>	<u>Daily Rate</u>	<u>Nonrecurring</u>	<u>Monthly Rate</u>	<u>Daily Rate</u>
(USOC)(1LXSX)	(1LFSX)	<u>Charge</u>	<u>(EUCXX)</u>	<u>(EUCXX)</u>
		(LCH)	(LCH)	(LCH)
\$ 5.02	\$ 0.50	\$210.00 (I)	\$ 30.00	\$ 3.00

(B) Standard Arrangements - (100-5000 Hz)

<u>Special Transport</u> <u>(Per Airline Mile)</u>		<u>Special Access Line</u>		
<u>Monthly Rate</u>	<u>Daily Rate</u>	<u>Nonrecurring</u>	<u>Monthly Rate</u>	<u>Daily Rate</u>
(USOC)(1LXSX)	(1LFSX)	<u>Charge</u>	<u>(EUCXX)</u>	<u>(EUCXX)</u>
		(LCH)	(LCH)	(LCH)
\$59.68	\$ 5.97	\$210.00 (I)	\$ 41.00	\$ 4.10

Issued: July 15, 2008

Effective: September 1, 2008

Chantel Mosby
Director, Tariffs and Compliance
Monroe, Louisiana

FACILITIES FOR INTRASTATE ACCESS

RECEIVED

5. SPECIAL ACCESS (Cont'd)

MAY 10 2000

5.7 Rates and Charges (Cont'd)

**MISSOURI
Public Service Commission**

5.7.3 Program Audio Facilities

(A) Standard Arrangements - (200-3500 Hz)

(USOC)	<u>Special Transport</u>		<u>Special Access Line</u>		
	<u>(Per Airline Mile)</u>		<u>Nonrecurring Charge</u>	<u>Monthly Rate</u>	<u>Daily Rate</u>
	<u>Monthly Rate</u>	<u>Daily Rate</u>			
	<u>(1LXSX)</u>	<u>(1LFSX)</u>	<u>(LCH)</u>	<u>(LCH)</u>	<u>(LCH)</u>
	\$ 5.02	\$ 0.50	\$200.00	\$ 30.00	\$ 3.00

(B) Standard Arrangements - (100-5000 Hz)

(USOC)	<u>Special Transport</u>		<u>Special Access Line</u>		
	<u>(Per Airline Mile)</u>		<u>Nonrecurring Charge</u>	<u>Monthly Rate</u>	<u>Daily Rate</u>
	<u>Monthly Rate</u>	<u>Daily Rate</u>			
	<u>(1LXSX)</u>	<u>(1LFSX)</u>	<u>(LCH)</u>	<u>(LCH)</u>	<u>(LCH)</u>
	\$59.68	\$ 5.97	\$200.00	\$ 41.00	\$ 4.10

FILED

AUG 01 2000

00 - 182

**MISSOURI
Public Service Commission**

Issued: May 10, 2000

Effective: August 1, 2000

CANCELLED
September 1, 2008
Missouri Public
Service Commission

Kenneth Matzdorff
Chief Operating Officer
Kansas City, Missouri

FACILITIES FOR INTRASTATE ACCESS

RECEIVED

5. SPECIAL ACCESS (Cont'd)

MAY 10 2000

5.7 Rates and Charges (Cont'd)

5.7.3 Program Audio Facilities (Cont'd)

**MISSOURI
Public Service Commission**

(C) Standard Arrangements - (50-8000 Hz)

(USOC)	<u>Special Transport</u>		<u>Special Access Line</u>		
	<u>(Per Airline Mile)</u>		<u>Nonrecurring Charge</u>	<u>Monthly Rate</u>	<u>Daily Rate</u>
	<u>Monthly Rate</u>	<u>Daily Rate</u>			
	<u>(1LXSX)</u>	<u>(1LFSX)</u>	<u>(LCH)</u>	<u>(LCH)</u>	<u>(LCH)</u>
	\$74.65	\$ 7.47	\$200.00	\$ 42.00	\$ 4.20

(D) Standard Arrangements - (50-15000 Hz)

(USOC)	<u>Special Transport</u>		<u>Special Access Line</u>		
	<u>(Per Airline Mile)</u>		<u>Nonrecurring Charge</u>	<u>Monthly Rate</u>	<u>Daily Rate</u>
	<u>Monthly Rate</u>	<u>Daily Rate</u>			
	<u>(1LXSX)</u>	<u>(1LFSX)</u>	<u>(LCH)</u>	<u>(LCH)</u>	<u>(LCH)</u>
	\$89.61	\$ 8.96	\$200.00	\$ 60.42	\$ 6.04

FILED

AUG 01 2000
00 - 182

**MISSOURI
Public Service Commission**

Issued: May 10, 2000

Effective: August 1, 2000

CANCELLED
October 19, 2009
Missouri Public
Service Commission
TN-2010-0092; YI-2010-0175

Kenneth Matzdorff
Chief Operating Officer
Kansas City, Missouri

FACILITIES FOR INTRASTATE ACCESS

RECEIVED

5. SPECIAL ACCESS (Cont'd)

MAY 10 2000

5.7 Rates and Charges (Cont'd)

5.7.3 Program Audio Facilities (Cont'd)

MISSOURI Public Service Commission

(E) Optional Arrangements - (50-15000 Hz Facilities only)

<u>Supplemental Features</u>			
<u>Conditioning - Program Audio</u>			
<u>Stereo Conditioning, per occurrence</u>			
<u>Nonrecurring</u>	<u>Monthly</u>	<u>Daily</u>	
<u>Charge</u>	<u>Rate</u>	<u>Rate</u>	
	<u>(XCS)</u>	<u>(XCS)</u>	
(USOC)	\$ 0.00	\$ 1.31	\$ 0.13

(F) Optional Arrangements - (All Bandwidths)

<u>Supplemental Features</u>			
<u>Program Audio Bridging (Per Port)</u>			
<u>Nonrecurring</u>	<u>Monthly</u>	<u>Daily</u>	
<u>Charge</u>	<u>Rate</u>	<u>Rate</u>	
	<u>(BCNPT)</u>	<u>(BCNPT)</u>	
(USOC)	\$ 0.00	\$ 19.15	\$ 1.92

FILED

AUG 01 2000
00 - 182

MISSOURI Public Service Commission

FACILITIES FOR INTRASTATE ACCESS

RECEIVED

5. SPECIAL ACCESS (Cont'd)

MAY 10 2000

5.7 Rates and Charges (Cont'd)

5.7.3 Program Audio Facilities (Cont'd)

**MISSOURI
Public Service Commission**

(F) Optional Arrangements - (All Bandwidths) (Cont'd)

(USOC)	<u>Supplemental Features</u>		
	<u>Conditioning Program Audio - Zero Loss, Per SAL</u>		
	<u>Nonrecurring Charge</u>	<u>Monthly Rate (XZB)</u>	<u>Daily Rate (XZB)</u>
	\$ 0.00	\$15.72	\$ 1.57

5.7.4. (Reserved for Future Use)

FILED

AUG 01 2000
00-182

**MISSOURI
Public Service Commission**

Issued: May 10, 2000

Effective: August 1, 2000

CANCELLED
October 19, 2009
Missouri Public
Service Commission
TN-2010-0092; YI-2010-0175

Kenneth Matzdorff
Chief Operating Officer
Kansas City, Missouri

FACILITIES FOR INTRASTATE ACCESS

5. SPECIAL ACCESS (Cont'd)

5.7 Rates and Charges (Cont'd)

5.7.5 Digital Data Service Facilities
(2.4, 4.8, 9.6, 56 Kbps)

(A) Standard Arrangements

<u>Special Transport</u>		<u>Special Access Line</u>		
All Speeds (Per Airline Mile)		All Speeds Nonrecurring	2.4, 4.8, and 9.6 Kbps	56 Kbps
<u>Monthly Rate</u>		<u>Charge</u>	<u>Monthly Rate</u>	<u>Monthly Rate</u>
(USOC)	(1LFSX)	(NRBDD)	(EUCXX) (LCH)	(EUCXX) (LCH)
	\$12.07 (I)	\$262.50 (I)	\$78.75 (I)	\$89.25 (I)

Issued: July 15, 2008

Effective: September 1, 2008

Chantel Mosby
Director, Tariffs and Compliance
Monroe, Louisiana

FACILITIES FOR INTRASTATE ACCESS

5. SPECIAL ACCESS (Cont'd)

5.7 Rates and Charges (Cont'd)

5.7.5 Digital Data Service Facilities
(2.4, 4.8, 9.6, 56 Kbps)

(A) Standard Arrangements

<u>Special Transport</u>		<u>Special Access Line</u>		
All Speeds (Per Airline Mile)		All Speeds Nonrecurring	2.4, 4.8, and 9.6 Kbps	56 Kbps
(USOC)	<u>Monthly Rate</u> (1LFSX)	<u>Charge</u> (NRBDD)	<u>Monthly Rate</u> (EUCXX) (LCH)	<u>Monthly Rate</u> (EUCXX) (LCH)
	\$11.50	\$250.00	\$75.00 (I)	\$85.00 (I)

Issued: August 1, 2005

Effective: September 1, 2005

Chantel Mosby
Manager, Tariffs and Compliance
Monroe, Louisiana

FILED

MO PSC

CANCELLED
September 1, 2008
Missouri Public
Service Commission

FACILITIES FOR INTRASTATE ACCESS

RECEIVED

5. SPECIAL ACCESS (Cont'd)

MAY 10 2000

5.7 Rates and Charges (Cont'd)

MISSOURI
Public Service Commission

5.7.5 Digital Data Service Facilities
(2.4, 4.8, 9.6, 56 Kbps)

(A) Standard Arrangements

(USOC)	<u>Special Transport</u>	<u>Special Access Line</u>		
	All Speeds (Per Airline Mile) <u>Monthly Rate</u> (1LPSX)	All Speeds Nonrecurring <u>Charge</u> (NRBDD)	2.4, 4.8 and 9.6 Kbps <u>Monthly Rate</u> (EUCXX) (LCH)	56 Kbps <u>Monthly Rate</u> (EUCXX) (LCH)
	\$11.50	\$250.00	\$73.50	\$83.00

CANCELLED

SEP 01 2005

By *lars 215*
Public Service Commission
MISSOURI

FILED

AUG 01 2000

00 - 182
MISSOURI

Public Service Commission

FACILITIES FOR INTRASTATE ACCESS

RECEIVED

5. SPECIAL ACCESS (Cont'd)

MAY 10 2000

5.7 Rates and Charges (Cont'd)

**MISSOURI
Public Service Commission**

5.7.5 Digital Data Service Facilities (Cont'd)
(2.4, 4.8, 9.6, 56 Kbps)

(B) Optional Arrangements

(USOC)	<u>Supplemental Features</u>	
	<u>DDS Bridging (Per Port)</u>	
	<u>Nonrecurring Charge</u>	<u>Monthly Rate</u>
		(BCNDA)
	\$ 0.00	\$11.00

FILED

AUG 01 2000
00 - 182
**MISSOURI
Public Service Commission**

Issued: May 10, 2000

Effective: August 1, 2000

CANCELLED
October 19, 2009
Missouri Public
Service Commission
TN-2010-0092; YI-2010-0175

Kenneth Matzdorff
Chief Operating Officer
Kansas City, Missouri

FACILITIES FOR INTRASTATE ACCESS

5. SPECIAL ACCESS (Cont'd)

5.7 Rates and Charges (Cont'd)

5.7.6 Multiplexing Arrangements

<u>DS1 to Voice*</u>	
<u>Nonrecurring Charge</u> (USOC)(MQ1, MQJ++)	<u>Monthly Rate</u> (MQ1, MQJ++)
\$800.00	\$194.25 (I)

<u>Digital Data Carrier Multiplexer</u>	
<u>Nonrecurring Charge</u> (USOC) (QMU)	<u>Monthly Rate</u> (QMU)
\$1,500.00	\$550.00

Digital Data Subrate Multiplexer

<u>One 64 Kbps to Twenty 2.4 Kbps</u>		<u>One 64 Kbps to Ten 4.8 Kbps</u>	
<u>Nonrecurring Charge</u> (USOC) (QSU24)	<u>Monthly Rate</u> (QSU24)	<u>Nonrecurring Charge</u> (QSU48)	<u>Monthly Rate</u> (QSU48)
\$800.00	\$160.00	\$800.00	\$120.00

<u>Digital Data Subrate Multiplexer</u> <u>One 64 Kbps Port to Five 9.6 Kbps</u>	
<u>Nonrecurring Charge</u> (USOC) (QSU96)	<u>Monthly Rate</u> (QSU96)
\$800.00	\$100.00

* All other Multiplexing Arrangements are provided on an Individual Case Basis as described in 5.6.5(B).

Issued: July 15, 2008

Effective: September 1, 2008

Chantel Mosby
Director, Tariffs and Compliance
Monroe, Louisiana

FACILITIES FOR INTRASTATE ACCESS

5. SPECIAL ACCESS (Cont'd)

5.7 Rates and Charges (Cont'd)

5.7.6 Multiplexing Arrangements

<u>DS1 to Voice*</u>			
<u>Nonrecurring Charge</u> (USOC)(MQ1, MQJ++)	<u>Monthly Rate</u> (MQ1, MQJ++)		
\$800.00	\$185.00 (I)		
<u>Digital Data Carrier Multiplexer</u>			
<u>Nonrecurring Charge</u> (USOC) (QMU)	<u>Monthly Rate</u> (QMU)		
\$1,500.00	\$550.00		
<u>Digital Data Subrate Multiplexer</u>			
<u>One 64 Kbps to Twenty 2.4 Kbps</u>		<u>One 64 Kbps to Ten 4.8 Kbps</u>	
<u>Nonrecurring Charge</u> (USOC) (QSU24)	<u>Monthly Rate</u> (QSU24)	<u>Nonrecurring Charge</u> (QSU48)	<u>Monthly Rate</u> (QSU48)
\$800.00	\$160.00	\$800.00	\$120.00
<u>Digital Data Subrate Multiplexer</u>			
<u>One 64 Kbps Port to Five 9.6 Kbps</u>			
<u>Nonrecurring Charge</u> (USOC) (QSU96)	<u>Monthly Rate</u> (QSU96)		
\$800.00	\$100.00		

* All other Multiplexing Arrangements are provided on an Individual Case Basis as described in 5.6.5(B).

Issued: August 1, 2005

Effective: September 1, 2005

Chantel Mosby
Manager, Tariffs and Compliance
Monroe, Louisiana

CANCELLED
September 1, 2008
Missouri Public
Service Commission

FILED
MO PSC

FACILITIES FOR INTRASTATE ACCESS

RECEIVED

5. SPECIAL ACCESS (Cont'd)

MAY 10 2000

5.7 Rates and Charges (Cont'd)

**MISSOURI
Public Service Commission**

5.7.6 Multiplexing Arrangements

		<u>DS1 to Voice*</u>	
	<u>Nonrecurring Charge</u>		<u>Monthly Rate</u>
(USOC)	(MQ1, MQJ++)		(MQ1, MQJ++)
	\$800.00		\$184.00

		<u>Digital Data Carrier Multiplexer</u>	
	<u>Nonrecurring Charge</u>		<u>Monthly Rate</u>
(USOC)	(QMU)		(QMU)
	\$1,500.00		\$550.00

		<u>Digital Data Subrate Multiplexer</u>					
		<u>One 64 Kbps to Twenty 2.4 Kbps</u>		<u>One 64 Kbps to Ten 4.8 Kbps</u>			
	<u>Nonrecurring Charge</u>		<u>Monthly Rate</u>		<u>Nonrecurring Charge</u>		<u>Monthly Rate</u>
(USOC)	(QSU24)		(QSU24)		(QSU48)		(QSU48)
	\$800.00		\$160.00		\$800.00		\$120.00

		<u>Digital Data Subrate Multiplexer</u>	
		<u>One 64 Kbps Port to Five 9.6 Kbps</u>	
	<u>Nonrecurring Charge</u>		<u>Monthly Rate</u>
(USOC)	(QSU96)		(QSU96)
	\$800.00		\$100.00

CANCELLED
SEP 01 2005
By *lars217*
Public Service Commission
MISSOURI

FILED
AUG 01 2000
182
MISSOURI
Public Service Commission

* All other Multiplexing Arrangements are provided on an Individual Case Basis as described in 5.6.5(B).

FACILITIES FOR INTRASTATE ACCESS

RECEIVED

5. SPECIAL ACCESS (Cont'd)

MAY 10 2000

5.7 Rates and Charges (Cont'd)

(Reserved for Future Use)

**MISSOURI
Public Service Commission**

FILED

AUG 01 2000

00-182

**MISSOURI
Public Service Commission**

Issued: May 10, 2000

Effective: August 1, 2000

CANCELLED
October 19, 2009
Missouri Public
Service Commission
TN-2010-0092; YI-2010-0175

Kenneth Matzdorff
Chief Operating Officer
Kansas City, Missouri

FACILITIES FOR INTRASTATE ACCESS

5. SPECIAL ACCESS (Cont'd)

5.7 Rates and Charges (Cont'd)

5.7.7 High Capacity Digital DS1 (1.544 Mbps) Facilities

(A) Standard Arrangements

<u>Special Access Line</u>				
<u>First System</u>		<u>Each Additional System</u>		
Nonrecurring	Monthly	Nonrecurring	Monthly	
<u>Charge</u>	<u>Rate</u>	<u>Charge</u>	<u>Rate</u>	
(USOC) (EUW)	(EUW)	(EU8)	(EU8)	
(1XCDX)	(1XCDX)	(1XCAX)	(1XCAX)	
		(EU4EX)	(EU4EX)	
		(1CKEX)	(1CKEX)	
\$945.00 (I)	\$315.00 (I)	\$136.50 (I)	\$165.37 (I)	
<u>Special Transport Termination</u>		<u>Special Transport (Per Airline Mile)</u>		
<u>Monthly Rate</u>		<u>Monthly Rate</u>		
(USOC) (TRG)		(1LFSX)		
\$31.50 (I)		\$23.10 (I)		

Issued: July 15, 2008

Effective: September 1, 2008

Chantel Mosby
Director, Tariffs and Compliance
Monroe, Louisiana

FACILITIES FOR INTRASTATE ACCESS

5. SPECIAL ACCESS (Cont'd)

5.7 Rates and Charges (Cont'd)

5.7.7 High Capacity Digital DS1 (1.544 Mbps) Facilities

(A) Standard Arrangements

<u>Special Access Line</u>					
<u>First System</u>		<u>Each Additional System</u>			
Nonrecurring <u>Charge</u>	Monthly <u>Rate</u>	Nonrecurring <u>Charge</u>	Monthly <u>Rate</u>		
(USOC) (EUW) (1XCDX)	(EUW) (1XCDX)	(EU8) (1XCAX) (EU4EX) (1CKEX)	(EU8) (1XCAX) (EU4EX) (1CKEX)		
\$900.00	\$300.00 (I)	\$130.00	\$157.50 (I)		
<u>Special Transport Termination</u>		<u>Special Transport (Per Airline Mile)</u>			
Monthly Rate		Monthly Rate			
(USOC)	(TRG)	(1LFSX)			
\$30.00		\$22.00 (I)			

Issued: August 1, 2005

Effective: September 1, 2005

Chantel Mosby
Manager, Tariffs and Compliance
Monroe, Louisiana

FILED

MO PSC

CANCELLED
September 1, 2008
Missouri Public
Service Commission

FACILITIES FOR INTRASTATE ACCESS

RECEIVED

5. SPECIAL ACCESS (Cont'd)

MAY 10 2000

5.7 Rates and Charges (Cont'd)

5.7.7 High Capacity Digital DS1 (1.544 Mbps) Facilities

MISSOURI
Public Service Commission

(A) Standard Arrangements

		<u>Special Access Line</u>			
		<u>First System</u>		<u>Each Additional System</u>	
	(USOC)	<u>Nonrecurring Charge</u> (EUW) (1XCDX)	<u>Monthly Rate</u> (EUW) (1XCDX)	<u>Nonrecurring Charge</u> (EU8) (1XCAX) (EU4EX) (1CKEX)	<u>Monthly Rate</u> (EU8) (1XCAX) (EU4EX) (1CKEX)
		\$900.00	\$295.00	\$130.00	\$150.00
		<u>Special Transport Termination</u>		<u>Special Transport (Per Airline Mile)</u>	
	(USOC)	<u>Monthly Rate</u> (TRG)		<u>Monthly Rate</u> (1LFSX)	
		\$30.00		\$21.60	

CANCELLED

SEP 01 2005
by 157RS219
Public Service Commission
MISSOURI

FILED

AUG 01 2000
00 - 182

MISSOURI
Public Service Commission

FACILITIES FOR INTRASTATE ACCESS

5. SPECIAL ACCESS (Cont'd)

5.7 Rates and Charges (Cont'd)

5.7.7 High Capacity Digital DS1 (1.544 Mbps) Facilities (Cont'd)

(B) Optional Arrangements

		<u>Supplemental Features</u>	
		<u>Automatic Protection Switching</u>	
	<u>Charge</u>		<u>Monthly Rate</u>
(USOC)	(APP)		(APP)
	\$700.00		\$100.00

		<u>SPECTRALAN Special Transport</u>
(USOC)	<u>Monthly Rate</u>	
	(1OXTX)	\$ 75.00

5.7.8 (Reserved for Future Use)

5.7.9 High Capacity Digital FT1 Facilities

(A) Standard Arrangements

(1) 2 X 56 Kbps or 2 X 64 Kbps

		<u>Special Access Line</u>			
	<u>Nonrecurring Charge</u>	<u>Monthly Rate</u>	<u>Special Transport</u>	<u>Special Transport Termination</u>	
(USOC)		(EU4JX) (1CKJX)	(1LFSX)	(TRG)	
	\$450.00	\$140.07 (I)	\$6.94 (I)	\$22.05 (I)	

(2) 4 X 56 Kbps or 4 X 64 Kbps

		<u>Special Access Line</u>			
	<u>Nonrecurring Charge</u>	<u>Monthly Rate</u>	<u>Special Transport</u>	<u>Special Transport Termination</u>	
(USOC)		(EU4JX) (1CKJX)	(1LFSX)	(TRG)	
	\$450.00	\$149.33 (I)	\$8.09 (I)	\$33.07 (I)	

Issued: July 15, 2008

Effective: September 1, 2008

Chantel Mosby
Director, Tariffs and Compliance
Monroe, Louisiana

FACILITIES FOR INTRASTATE ACCESS

5. SPECIAL ACCESS (Cont'd)

5.7 Rates and Charges (Cont'd)

5.7.7 High Capacity Digital DS1 (1.544 Mbps) Facilities (Cont'd)

(B) Optional Arrangements

		<u>Supplemental Features</u>	
		<u>Automatic Protection Switching</u>	
	<u>Nonrecurring</u>		<u>Monthly</u>
(USOC)	<u>Charge</u>		<u>Rate</u>
	(APP)		(APP)
	\$700.00		\$100.00

		<u>SPECTRALAN Special Transport</u>
		<u>Monthly Rate</u>
(USOC)	(1OXTX)	
		\$ 75.00

5.7.8 (Reserved for Future Use)

5.7.9 High Capacity Digital FT1 Facilities

(A) Standard Arrangements

(1) 2 X 56 Kbps or 2 X 64 Kbps

		<u>Special Access Line</u>			
	<u>Nonrecurring</u>	<u>Monthly Rate</u>		<u>Special</u>	<u>Special</u>
(USOC)	<u>Charge</u>	(EU4JX)		<u>Transport</u>	<u>Transport</u>
		(1CKJX)		(1LFSX)	<u>Termination</u>
					(TRG)
	\$450.00	\$133.40 (I)		\$6.61 (I)	\$21.00 (I)

(2) 4 X 56 Kbps or 4 X 64 Kbps

		<u>Special Access Line</u>			
	<u>Nonrecurring</u>	<u>Monthly Rate</u>		<u>Special</u>	<u>Special</u>
(USOC)	<u>Charge</u>	(EU4JX)		<u>Transport</u>	<u>Transport</u>
		(1CKJX)		(1LFSX)	<u>Termination</u>
					(TRG)
	\$450.00	\$142.22 (I)		\$7.71 (I)	\$31.50 (I)

Issued: July 16, 2007

Effective: September 1, 2007

Chantel Mosby
Manager, Tariffs and Compliance
Monroe, Louisiana

CANCELLED
September 1, 2008
Missouri Public
Service Commission

FILED
Missouri Public
Service Commission

FACILITIES FOR INTRASTATE ACCESS

5. SPECIAL ACCESS (Cont'd)

5.7 Rates and Charges (Cont'd)

5.7.7 High Capacity Digital DS1 (1.544 Mbps) Facilities (Cont'd)

(B) Optional Arrangements

		<u>Supplemental Features</u>	
		<u>Automatic Protection Switching</u>	
		<u>Nonrecurring</u>	<u>Monthly</u>
		<u>Charge</u>	<u>Rate</u>
(USOC)	(APP)	(APP)	(APP)
		\$700.00	\$100.00
		<u>SPECTRALAN Special Transport</u>	
		<u>Monthly Rate</u>	
(USOC)	(1OXTX)		
		\$ 75.00	

5.7.8 (Reserved for Future Use)

5.7.9 High Capacity Digital FT1 Facilities

(A) Standard Arrangements

(1) 2 X 56 Kbps or 2 X 64 Kbps

		<u>Special Access Line</u>			
		<u>Nonrecurring</u>	<u>Monthly Rate</u>	<u>Special</u>	<u>Special</u>
		<u>Charge</u>	<u>(EU4JX)</u>	<u>Transport</u>	<u>Transport</u>
		(USOC)	(1CKJX)	(1LFSX)	Termination
					(TRG)
		\$450.00	\$127.05 (I)	\$6.30 (I)	\$20.00

(2) 4 X 56 Kbps or 4 X 64 Kbps

		<u>Special Access Line</u>			
		<u>Nonrecurring</u>	<u>Monthly Rate</u>	<u>Special</u>	<u>Special</u>
		<u>Charge</u>	<u>(EU4JX)</u>	<u>Transport</u>	<u>Transport</u>
		(USOC)	(1CKJX)	(1LFSX)	Termination
					(TRG)
		\$450.00	\$135.45 (I)	\$7.35 (I)	\$30.00

Issued: August 1, 2005

Effective: September 1, 2005

Chantel Mosby
Manager, Tariffs and Compliance
Monroe, Louisiana

CANCELLED
Sept. 1, 2007
Missouri Public
Service Commission

FILED
MO PSC

FACILITIES FOR INTRASTATE ACCESS

RECEIVED

5. SPECIAL ACCESS (Cont'd)

MAY 10 2000

5.7 Rates and Charges (Cont'd)

5.7.7 High Capacity Digital DS1 (1.544 Mbps) Facilities **MISSOURI Public Service Commission**

(B) Optional Arrangements

		<u>Supplemental Features</u>	
		<u>Automatic Protection Switching</u>	
(USOC)	Nonrecurring	Monthly	
	<u>Charge</u>	<u>Rate</u>	
	(APP)	(APP)	
	\$700.00	\$100.00	

(USOC)	<u>SPECTRALAN Special Transport</u>
	<u>Monthly Rate</u>
	(1OXTX)
	\$ 75.00

CANCELLED

SEP 01 2005
 dy 16hrs 219.1
MISSOURI Public Service Commission

5.7.8 (Reserved for Future Use)

5.7.9 High Capacity Digital FT1 Facilities

(A) Standard Arrangements

(1) 2 X 56 Kbps or 2 X 64 Kbps

		<u>Special Access Line</u>			
(USOC)	Nonrecurring	Monthly Rate	Special Transport	Special Transport	
	<u>Charge</u>	(EU4JX) (1CKJX)	(1LFSX)	Termination	(TRG)
	\$450.00	\$121.00	\$6.00	\$20.00	

(2) 4 X 56 Kbps or 4 X 64 Kbps
Special Access Line

(USOC)	Nonrecurring	Monthly Rate	Special Transport	Special Transport	
	<u>Charge</u>	(EU4JX) (1CKJX)	(1LFSX)	Termination	(TRG)
	\$450.00	\$129.00	\$7.00	\$30.00	

FILED

AUG 01 2000
 00 - 182
MISSOURI Public Service Commission

FACILITIES FOR INTRASTATE ACCESS

5. SPECIAL ACCESS (Cont'd)
 5.7 Rates and Charges (Cont'd)
 5.7.9 High Capacity Digital FT1 Facilities (Cont'd)

(A) Standard Arrangements (Cont'd)

- (3) 6 X 56 Kbps or 6 X 64 Kbps

Special Access Line

(USOC)	<u>Nonrecurring Charge</u>	<u>Monthly Rate</u> (EU4JX) (1CKJX)	<u>Special Transport</u> (1LFSX)	<u>Special Transport Termination</u> (TRG)
	\$450.00	\$157.43 (I)	\$9.26 (I)	\$44.10 (I)

(B) FT1 Optional Payment Plan

- (1) 2 X 56 Kbps or 2 X 64 Kbps

Special Access Line

(USOC)	<u>One Year Monthly Rate</u> (EU4KX) (1CKKX)	<u>Three Year Monthly Rate</u> (EU4KX) (1CKKX)	<u>Five Year Monthly Rate</u> (EU4KX) (1CKKX)	<u>Special Transport</u> (1LFSX)	<u>Special Transport Termination</u> (TRG)
	\$127.33 (I)	\$114.59 (I)	\$101.87 (I)	\$6.94 (I)	\$22.05 (I)

- (2) 4 X 56 Kbps or 4 X 64 Kbps

Special Access Line

(USOC)	<u>One Year Monthly Rate</u> (EU4KX) (1CKKX)	<u>Three Year Monthly Rate</u> (EU4KX) (1CKKX)	<u>Five Year Monthly Rate</u> (EU4KX) (1CKKX)	<u>Special Transport</u> (1LFSX)	<u>Special Transport Termination</u> (TRG)
	\$138.91 (I)	\$125.02 (I)	\$111.13 (I)	\$8.09 (I)	\$33.07 (I)

- (3) 6 X 56 Kbps or 6 X 64 Kbps

Special Access Line

(USOC)	<u>One Year Monthly Rate</u> (EU4KX) (1CKKX)	<u>Three Year Monthly Rate</u> (EU4KX) (1CKKX)	<u>Five Year Monthly Rate</u> (EU4KX) (1CKKX)	<u>Special Transport</u> (1LFSX)	<u>Special Transport Termination</u> (TRG)
	\$150.48 (I)	\$135.43 (I)	\$120.39 (I)	\$9.26 (I)	\$44.10 (I)

Issued: July 15, 2008

Effective: September 1, 2008

Chantel Mosby
Director, Tariffs and Compliance
Monroe, Louisiana

FACILITIES FOR INTRASTATE ACCESS

5. SPECIAL ACCESS (Cont'd)

5.7 Rates and Charges (Cont'd)

5.7.9 High Capacity Digital FT1 Facilities (Cont'd)

(A) Standard Arrangements (Cont'd)

(3) 6 X 56 Kbps or 6 X 64 Kbps

Special Access Line

(USOC)	Nonrecurring <u>Charge</u>	<u>Monthly Rate</u> (EU4JX) (1CKJX)	<u>Special Transport</u> (1LFSX)	<u>Special Transport Termination</u> (TRG)
	\$450.00	\$149.94 (I)	\$8.82 (I)	\$42.00 (I)

(B) FT1 Optional Payment Plan

(1) 2 X 56 Kbps or 2 X 64 Kbps

Special Access Line

(USOC)	<u>One Year Monthly Rate</u> (EU4KX) (1CKKX)	<u>Three Year Monthly Rate</u> (EU4KX) (1CKKX)	<u>Five Year Monthly Rate</u> (EU4KX) (1CKKX)	<u>Special Transport</u> (1LFSX)	<u>Special Transport Termination</u> (TRG)
	\$121.27 (I)	\$109.14 (I)	\$97.02 (I)	\$6.61 (I)	\$21.00 (I)

(2) 4 X 56 Kbps or 4 X 64 Kbps

Special Access Line

(USOC)	<u>One Year Monthly Rate</u> (EU4KX) (1CKKX)	<u>Three Year Monthly Rate</u> (EU4KX) (1CKKX)	<u>Five Year Monthly Rate</u> (EU4KX) (1CKKX)	<u>Special Transport</u> (1LFSX)	<u>Special Transport Termination</u> (TRG)
	\$132.30 (I)	\$119.07 (I)	\$105.84 (I)	\$7.71 (I)	\$31.50 (I)

(3) 6 X 56 Kbps or 6 X 64 Kbps

Special Access Line

(USOC)	<u>One Year Monthly Rate</u> (EU4KX) (1CKKX)	<u>Three Year Monthly Rate</u> (EU4KX) (1CKKX)	<u>Five Year Monthly Rate</u> (EU4KX) (1CKKX)	<u>Special Transport</u> (1LFSX)	<u>Special Transport Termination</u> (TRG)
	\$143.32 (I)	\$128.99 (I)	\$114.66 (I)	\$8.82 (I)	\$42.00 (I)

Issued: July 16, 2007

Effective: September 1, 2007

Chantel Mosby
Manager, Tariffs and Compliance
Monroe, Louisiana

CANCELLED
September 1, 2008
Missouri Public
Service Commission

FILED
Missouri Public
Service Commission

FACILITIES FOR INTRASTATE ACCESS

5. SPECIAL ACCESS (Cont'd)

5.7 Rates and Charges (Cont'd)

5.7.9 High Capacity Digital FT1 Facilities (Cont'd)

(A) Standard Arrangements (Cont'd)

(3) 6 X 56 Kbps or 6 X 64 Kbps

Special Access Line

(USOC)	<u>Nonrecurring Charge</u>	<u>Monthly Rate</u> (EU4JX) (1CKJX)	<u>Special Transport</u> (1LFSX)	<u>Special Transport Termination</u> (TRG)
	\$450.00	\$142.80 (I)	\$8.40 (I)	\$40.00

(B) FT1 Optional Payment Plan

(1) 2 X 56 Kbps or 2 X 64 Kbps

Special Access Line

(USOC)	<u>One Year Monthly Rate</u> (EU4KX) (1CKKX)	<u>Three Year Monthly Rate</u> (EU4KX) (1CKKX)	<u>Five Year Monthly Rate</u> (EU4KX) (1CKKX)	<u>Special Transport</u> (1LFSX)	<u>Special Transport Termination</u> (TRG)
	\$115.50 (I)	\$103.95 (I)	\$92.40 (I)	\$6.30 (I)	\$20.00

(2) 4 X 56 Kbps or 4 X 64 Kbps

Special Access Line

(USOC)	<u>One Year Monthly Rate</u> (EU4KX) (1CKKX)	<u>Three Year Monthly Rate</u> (EU4KX) (1CKKX)	<u>Five Year Monthly Rate</u> (EU4KX) (1CKKX)	<u>Special Transport</u> (1LFSX)	<u>Special Transport Termination</u> (TRG)
	\$126.00 (I)	\$113.40 (I)	\$100.80 (I)	\$7.35 (I)	\$30.00

(3) 6 X 56 Kbps or 6 X 64 Kbps

Special Access Line

(USOC)	<u>One Year Monthly Rate</u> (EU4KX) (1CKKX)	<u>Three Year Monthly Rate</u> (EU4KX) (1CKKX)	<u>Five Year Monthly Rate</u> (EU4KX) (1CKKX)	<u>Special Transport</u> (1LFSX)	<u>Special Transport Termination</u> (TRG)
	\$136.50 (I)	\$122.85 (I)	\$109.20 (I)	\$8.40 (I)	\$40.00

Issued: August 1, 2005

Effective: September 1, 2005

CANCELLED
Sept. 1, 2007
Missouri Public
Service Commission

Chantel Mosby
Manager, Tariffs and Compliance
Monroe, Louisiana

FILED
MO PSC

FACILITIES FOR INTRASTATE ACCESS

RECEIVED

5. SPECIAL ACCESS (Cont'd)

MAY 10 2000

5.7 Rates and Charges (Cont'd)

5.7.9 High Capacity Digital FT1 Facilities (Cont'd)

MISSOURI
Public Service Commission

(A) Standard Arrangements (Cont'd)

(3) 6 X 56 Kbps or 6 X 64 Kbps

Special Access Line

(USOC)	Nonrecurring Charge	Monthly Rate (EU4JX) (1CKJX)	Special Transport (1LFSX)	Special Transport Termination (TRG)
	\$450.00	\$136.00	\$8.00	\$40.00

(B) FT1 Optional Payment Plan

(1) 2 X 56 Kbps or 2 X 64 Kbps

Special Access Line

(USOC)	One Year Monthly Rate (EU4KX) (1CKKX)	Three Year Monthly Rate (EU4KX) (1CKKX)	Five Year Monthly Rate (EU4KX) (1CKKX)	Special Transport (1LFSX)	Special Transport Termination (TRG)
	\$110.00	\$99.00	\$88.00	\$6.00	\$20.00

(2) 4 X 56 Kbps or 4 X 64 Kbps

Special Access Line

(USOC)	One Year Monthly Rate (EU4KX) (1CKKX)	Three Year Monthly Rate (EU4KX) (1CKKX)	Five Year Monthly Rate (EU4KX) (1CKKX)	Special Transport (1LFSX)	Special Transport Termination (TRG)
	\$120.00	\$108.00	\$96.00	\$7.00	\$30.00

(3) 6 X 56 Kbps or 6 X 64 Kbps

Special Access Line

(USOC)	One Year Monthly Rate (EU4KX) (1CKKX)	Three Year Monthly Rate (EU4KX) (1CKKX)	Five Year Monthly Rate (EU4KX) (1CKKX)	Special Transport (1LFSX)	Special Transport Termination (TRG)
	\$130.00	\$117.00	\$104.00	\$8.00	\$40.00

CANCELLED

SEP 01 2005

By *WRS* 219.2
Public Service Commission
MISSOURI

FILED

AUG 01 2000
00 - 182

MISSOURI
Public Service Commission

Issued: May 10, 2000

Effective: August 1, 2000

Kenneth Matzdorff
Chief Operating Officer
Kansas City, Missouri

FACILITIES FOR INTRASTATE ACCESS

RECEIVED

5. SPECIAL ACCESS (Cont'd)

MAY 10 2000

5.8 Miscellaneous Special Access Services

**MISSOURI
Public Service Commission**

5.8.1 Clear Channel Capability

(A) Description of Service

An arrangement that allows the customer to transport 1.536 Mbps of information through a DS1 with no constraint on the quantity or sequence of one (mark) and zero (space) bits utilizing the Bipolar with Eight Zero Substitution (B8ZS) method of providing bit sequence independence. This arrangement is capable of transporting DS1 signals which utilize Superframe or Extended Superframe Format (ESF) as defined by the American National Standards Institute (ANSI) T1.107-1988 standard. The installation interval for Clear Channel Capability may exceed standard intervals where equipment in the central office is not readily available. The charges apply on a per SAL basis.

This arrangement requires the customer signal at the channel interface to conform to the B8ZS method of providing bit sequence independence, as described in ANSI T1.102-1987 and Section 6103 of the GTE Technical Interface Reference Manual.

(B) Rates, per DS1 SAL:

(USOC)	<u>Nonrecurring Charge</u>	<u>Monthly Rate</u> (CCO)
	\$90.00	\$24.00

5.9 Individual Case Basis Rates and Charges

Rates and Charges for Special Access Service provided on an individual case basis are filed following:

<u>Customer Name</u>	<u>Description and Location</u>	<u>MTL/NRC MRC</u>	<u>Termination Liability Period</u>
----------------------	---------------------------------	--------------------	-------------------------------------

FILED

AUG 01 2000

00 - 182

**MISSOURI
Public Service Commission**

Issued: May 10, 2000

Effective: August 1, 2000

CANCELLED
October 19, 2009
Missouri Public
Service Commission
TN-2010-0092; YI-2010-0175

Kenneth Matzdorff
Chief Operating Officer
Kansas City, Missouri

RECEIVED

FACILITIES FOR INTRASTATE ACCESS

MAY 10 2000

TABLE OF CONTENTS

MISSOURI Public Service Commission

6. MISCELLANEOUS SERVICES

- 6.1 General 223
- 6.2 Additional Labor 224
 - (A) Overtime Installation 224
 - (B) Overtime Repair 224
 - (C) Additional Installation Testing 224
 - (D) Standby 224
 - (E) Testing and Maintenance with Other Telephone Companies 224
 - (F) (Reserved for Future Use) 224
 - (G) Charges for Additional Labor 225
- 6.3 Maintenance of Service Charge 227
- 6.4 Telecommunications Service Priority (TSP) System 228
 - (A) Description of the Service 228
 - (B) Obtaining TSP System Service 228
 - (C) Provisioning Priority 228
 - (D) Restoration Priority 229
 - (E) Obligations of the Customer 229
 - (F) Obligations of the Telephone Company 230
 - (G) Rates and Charges 230
- 6.5 Balloting and Allocation Process For Equal Access 233
 - (A) End User Notification and Equal Access Balloting Process 233
 - (B) Allocation Process 233.1
 - (C) Interexchange Carrier Customer Lists 234
 - (D) End User Choice Discrepancy 235
 - (E) Balloting and Allocation Procedure for Public and Semipublic Pay Telephones 236
 - (F) PIC and IPIC Charge Application 237
 - (G) Multi-party End Users 238
 - (H) Cancellation of a Carrier Participation 238
 - (I) Liability of the Telephone Company 238
 - (J) (Reserved for Future Use) 238
 - (K) Carrier Desired Due Date (ICDDD) for PIC or IPIC Installation 238
 - (L) Nonrecurring Charge for Primary InterLATA Carrier (PIC) on Primary IntraLATA Carrier (IPIC) 239
 - (M) Nonrecurring Charge for Unauthorized PIC or IPIC Changes 239

FILED

AUG 01 2000 00-182

MISSOURI Public Service Commission

FACILITIES FOR INTRASTATE ACCESS

RECEIVED

TABLE OF CONTENTS (Cont'd)

MAY 10 2000

		MISSOURI Public Service Commission	Sheet
6.	<u>MISCELLANEOUS SERVICES</u>		
6.6	<u>Additional Testing</u>		240
	(A) Switched Access Testing		241
	(1) Additional Cooperative Acceptance Testing		241
	(2) Automatic Scheduled Testing		241
	(3) Additional Cooperative Scheduled Testing		242
	(4) Additional Manual Scheduled Testing		243
	(5) Nonscheduled Testing		243
	(6) Obligations of the Customer		245
	(B) Special Access Testing		245
	(1) Additional Cooperative Acceptance Testing		245
	(2) Nonscheduled Testing		245
	(3) Obligation of the Customer		246
	(C) Rates and Charges		247
	(1) Automatic Scheduled Testing		247
	(2) Additional Cooperative Scheduled Testing		247
	(3) Additional Manual Scheduled Testing		247
6.7	(Reserved for Future Use)		248
6.8	<u>End User/Agent Lists</u>		249
	(A) Presubscription List		249
	(B) Allocation Lists		250
6.8.1	Rates and Charges		251
	(A) Initial and Allocation Lists		251
6.9	<u>Billing Name and Address Service</u>		252
6.9.1	Rates and Charges		253

FILED

AUG 01 2000
00-182
MISSOURI
Public Service Commission

Original Sheet 223
RECEIVED

FACILITIES FOR INTRASTATE ACCESS

MAY 10 2000

6. MISCELLANEOUS SERVICES

6.1 General

**MISSOURI
Public Service Commission**

Miscellaneous Services available to the customer include the following:

- (A) Additional Labor (i.e., Overtime Installation, Overtime Repair, Additional Installation Testing, Standby, Testing and Maintenance with Other Telephone Companies)
- (B) Maintenance of Service
- (C) Telecommunications Service Priority (TSP) System
- (D) Balloting and Allocation Process For Equal Access
- (E) Additional Testing
- (F) End User List
- (G) Billing Name and Address Service

These services are described in detail as set forth in 6.2 through 6.9 following.

FILED

AUG 01 2000
00 - 182

**MISSOURI
Public Service Commission**

Issued: May 10, 2000

Effective: August 1, 2000

CANCELLED
October 19, 2009
Missouri Public
Service Commission
TN-2010-0092; YI-2010-0175

Kenneth Matzdorff
Chief Operating Officer
Kansas City, Missouri

Original Sheet 224
RECEIVED

FACILITIES FOR INTRASTATE ACCESS

MAY 10 2000

6. MISCELLANEOUS SERVICES (Cont'd)

6.2 Additional Labor**MISSOURI
Public Service Commission**

Additional Labor is that labor requested by the customer on a given FIA and agreed to by the Telephone Company as set forth in (A) through (E) following. The Telephone Company will notify the customer that Additional Labor charges as set forth in (G) following will apply before any Additional Labor is undertaken. Additional Labor charges will also apply if the requirement for the Additional Labor is the fault of the customer or parties on whose behalf it acts.

(A) Overtime Installation

Overtime installation is that Telephone Company installation effort outside the business day. Overtime rates will apply anytime outside the business day and all day Saturday. Premium time rates will apply all day Sunday and on all Telephone Company approved holidays. For applicable holidays in each jurisdiction contact Issuing Carrier identified on Title Pages 2 and 3 preceding.

(B) Overtime Repair

Overtime repair is Telephone Company repair which could have been performed during the normal business day, but that is delayed at the specific request of the customer to a later time period which is outside the normal business day or to a weekend day or holiday. The request will result in the application of overtime rates anytime outside the business day and all day Saturday. Premium time rates will apply on Sunday and Telephone Company approved holidays. These rates, as set forth in Section 6.2 following, will only apply when there is a delay of repair at the request of the customer to the time periods stated above.

(C) Additional Installation Testing

Additional installation testing is that testing performed by the Telephone Company at the time of installation which is in addition to normal pre-service and acceptance testing.

(D) Standby

Standby includes all time in excess of one-half (1/2) hour during which Telephone Company personnel are available to make coordinated tests on a given FIA. The standby charge applies only when Telephone Company personnel must wait more than 30 minutes beyond a prearranged, mutually agreed appointment time. Standby charges will cease when testing begins, or when Telephone Company personnel are released from the standby requirement, or when testing is rescheduled for a later date or time. Charges will not be applicable if Telephone Company personnel cause the delay.

(E) Testing and Maintenance with Other Telephone Companies

Additional testing, maintenance, or repair of facilities which connect to facilities of other telephone companies, which is in addition to normal effort required to test, maintain, or repair facilities provided solely by the Telephone Company.

(F) (Reserved for Future Use)

FILED

AUG 01 2000

00 - 182

**MISSOURI
Public Service Commission**

FACILITIES FOR INTRASTATE ACCESS

RECEIVED

6. MISCELLANEOUS SERVICES (Cont'd)

MAY 10 2000

6.2 Additional Labor (Cont'd)

MISSOURI Public Service Commission

(G) Charges for Additional Labor

Labor Periods

		<u>Basic Time, Business Day, Per Technician</u>	
	<u>First Half Hour</u>		<u>Each Additional Half Hour</u>
(USOC)	<u>or Fraction Thereof</u>		<u>or Fraction Thereof</u>
	(UBCXT)		(UBCXT)
	(USMXT)		(USMXT)
	(USSXT)		(USSXT)
	(SNTXT)		(SNTXT)
	(SNOXT)		(SNOXT)
	(ALH)		(ALH)
	(ALT)		(ALT)
	(ALK)		(ALK)
	\$21.88		\$14.58

Labor Periods

		<u>Overtime, Outside the Business Day, Per Technician*</u>	
	<u>First Half Hour</u>		<u>Each Additional Half Hour</u>
(USOC)	<u>or Fraction Thereof</u>		<u>or Fraction Thereof</u>
	(UBCOT)		(UBCOT)
	(USMOT)		(USMOT)
	(USSOT)		(USSOT)
	(SNTOT)		(SNTOT)
	(SNOOT)		(SNOOT)
	(ALH)		(ALH)
	(ALT)		(ALT)
	(ALK)		(ALK)
	\$27.32		\$18.21

Labor Periods

		<u>Premium Time, Outside the Business Day, Per Technician*</u>	
	<u>First Half Hour</u>		<u>Each Additional Half Hour</u>
(USOC)	<u>or Fraction Thereof</u>		<u>or Fraction Thereof</u>
	(UBCPT)		(UBCPT)
	(USMPT)		(USMPT)
	(USSPT)		(USSPT)
	(SNTPT)		(SNTPT)
	(SNOPT)		(SNOPT)
	(ALH)		(ALH)
	(ALT)		(ALT)
	(ALK)		(ALK)
	\$32.76		\$21.83

FILED

AUG 01 2000

00-182

MISSOURI Public Service Commission

* A call out of a Telephone Company employee at a time not consecutive with the business day is subject to a minimum charge of four hours.

FACILITIES FOR INTRASTATE ACCESS

RECEIVED

- 6. MISCELLANEOUS SERVICES (Cont'd)
(Reserved for Future Use)

MAY 10 2000

MISSOURI
Public Service Commission

FILED

AUG 01 2000
00 - 182

MISSOURI
Public Service Commission

Issued: May 10, 2000

Effective: August 1, 2000

Kenneth Matzdorff
Chief Operating Officer
Kansas City, Missouri

CANCELLED
October 19, 2009
Missouri Public
Service Commission
TN-2010-0092; YI-2010-0175

FACILITIES FOR INTRASTATE ACCESS

RECEIVED

MAY 10 2000

6. MISCELLANEOUS SERVICES (Cont'd)6.3 Maintenance of Service Charge (USOC - MVV)MISSOURI
Public Service Commission

- (A) When a customer reports trouble to the Telephone Company for clearance, the customer shall be responsible for payment of a Maintenance of Service Charge when Telephone Company personnel are dispatched to the customer's location and no trouble is found in the Telephone Company's facilities. Failure of Telephone Company personnel to find trouble in Telephone Company facilities will result in no charge if the trouble is actually in those facilities, but not discovered at the time.

In this case, or in (B) following, no credit allowance will be applicable for the interruption involved, unless the trouble is found in the Telephone Company's facilities.

- (B) The customer shall be responsible for payment of a Maintenance of Service Charge when the Telephone Company dispatches personnel to the customer's location and the trouble is in equipment or communications systems provided by other than the Telephone Company or in detariffed CPE provided by the Telephone Company.
- (C) The Maintenance of Service Charge time period will begin when Telephone Company personnel are dispatched. This will only include the actual time required to reach the customer's location and perform an investigation. The time period will end when the investigation is finished. The labor charge as set forth in 6.2 (G) preceding will apply to Maintenance of Service at the appropriate Basic, Overtime or Premium rate. These charges apply whether the trouble is in the equipment of communications systems provided by other than the Telephone Company, or in detariffed CPE provided by the Telephone Company.

FILEDAUG 01 2000
00 - 182MISSOURI
Public Service Commission

Issued: May 10, 2000

Effective: August 1, 2000

CANCELLED
October 19, 2009
Missouri Public
Service Commission
TN-2010-0092; YI-2010-0175

Kenneth Matzdorff
Chief Operating Officer
Kansas City, Missouri

FACILITIES FOR INTRASTATE ACCESS

RECEIVED

MAY 10 2000

6. MISCELLANEOUS SERVICES (Cont'd)

MISSOURI Public Service Commission

6.4 Telecommunications Service Priority (TSP) System

(A) Description of the Service

The TSP System is a service that provides for the priority provisioning and/or restoration of National Security Emergency Preparedness (NSEP) telecommunications services. The TSP System applies only to NSEP services, includes both Switched and Special FIA and provides the Telephone Company with a guide to the sequence in which services are to be provisioned and/or restored.

All FIA that can be identified by a unique circuit identifier can be provisioned for NSEP service by the Telephone Company.

The rates and charges associated with a customer subscribing to the TSP System are as specified in Section 6.4(G).

(B) Obtaining TSP System Service

The Executive Office of the President through the TSP Program Office, is empowered with the authority to receive, evaluate and process requests for NSEP services. The TSP Program Office makes the priority level assignments and issues the TSP authorization code reflecting the priority assignment associated with a request. The customer provides the TSP authorization code, in addition to all the other details necessary to complete the order (ASR) to the Telephone Company to obtain TSP System service.

The TSP authorization code, assigned on a per ASR basis, consists of a 12-character field consisting of a nine-character control ID followed by a dash and a two-character field specifying the priority level assignment. Its structure is as follows:

TSPxxxxxn-yy

The "x"s represent a sequence of numbers unique to each TSP authorization code and the "n" is a one character alphanumeric check digit. The first "y" contains the provisioning priority level assignment and the second "y" contains the restoration priority level assignment.

(C) Provisioning Priority

If the customer requires service within a shorter time interval than the Telephone Company can provide, and the requested service qualifies for NSEP, the customer may elect to invoke NSEP Treatment and obtain the appropriate provisioning priority assignment from the TSP Program Office. Acceptable assignment code values are: E, 1, 2, 3, 4, 5 or 0.

The assignment of the value "E" denotes Emergency Provisioning and implies the service has the most critical provisioning requirements and the Telephone Company will respond accordingly. The Telephone Company will take immediate action to provide the requested service at the earliest possible date. Rates and charges associated with "E" provisioning are as specified in Section 6.4(G) (2) (a).

FILED

AUG 01 2000 00-182

MISSOURI Public Service Commission

FACILITIES FOR INTRASTATE ACCESS

RECEIVED6. MISCELLANEOUS SERVICES (Cont'd)

MAY 10 2000

6.4 Telecommunications Service Priority (TSP) System (Cont'd)**MISSOURI
Public Service Commission**(C) Provisioning Priority (Cont'd)

The assignment values of 1, 2, 3, 4 and 5 are treated as essential service priorities and the Company will adjust its available resources to meet the customer's requested due date. Rates and charges associated with invoking this priority treatment are specified in Section 6.4(G)(2)(b). The value "0" implies no provisioning priority.

(D) Restoration Priority

A TSP authorization code for restoration priority classifies the service as being among the nation's most important NSEP telecommunications services. The Company will restore these services before services without restoration priority assignments in the order of priority assignments. Acceptable values are: 1, 2, 3, 4, 5 or 0 with the value "1" being the highest priority.

When the Company recognizes a TSP as being out of service, unusable or receives a trouble report, available resources will be dispatched to restore the service as quickly as practicable. A priority value of 1, 2 or 3 requires dispatch outside normal business hours if necessary to restore the service. A priority value of 4 or 5 only requires dispatch outside of normal business hours if the next business day is more than 24 hours away. If the value "0" has been assigned, then no restoration priority is applicable to this service.

The minimum period for service is one month.

(E) Obligations of the Customer

- (1) In all instances, the customer is responsible for obtaining the appropriate TSP authorization code and providing that code to the Telephone Company.
- (2) The TSP System service customer must also be the customer for the FIA with which TSP service is associated. Only the customer or its authorized agent as indicated in a letter of agency on file with the Telephone Company is allowed to order TSP System service.
- (3) All points of a multipoint service configuration must have the same restoration priority assignment and must satisfy the requirements of that assignment.
- (4) In obtaining TSP System service, the customer consents to the release of certain information by the Telephone Company to the federal government in order to maintain and administer the TSP System. Such information includes: the customer's name, telephone number and mailing address, the TSP authorization code and the circuit or service ID number associated with the NSEP service.
- (5) The Telephone Company will attempt to notify the customer of expected charges. The customer when invoking NSEP Treatment, recognizes that quoting charges and obtaining permission beforehand may not be practicable and may cause unnecessary delays and, as a result, grants the Telephone Company the right to quote and bill charges after provisioning of the service.
- (6) During certain emergencies, the customer may request TSP assignments verbally and the Telephone Company will accept such verbal notification. The customer must submit a written order (ASR) to the Telephone Company within two working days following the verbal request. If the written order (ASR) is not received within two working days, all applicable rates and charges accumulated to date to provision TSP System service, become immediately due and payable and the requested TSP priority is revoked.

FILED

Issued: May 10, 2000

Effective: August 1, 2000

AUG 01 2000
0 0 1 8 2

CANCELLED
October 19, 2009
Missouri Public
Service Commission
TN-2010-0092; YI-2010-0175

Kenneth Matzdorff
Chief Operating Officer
Kansas City, Missouri

**MISSOURI
Public Service Commission**

FACILITIES FOR INTRASTATE ACCESS

RECEIVED6. MISCELLANEOUS SERVICES (Cont'd)

MAY 10 2000

6.4 Telecommunications Service Priority (TSP) System (Cont'd)**MISSOURI
Public Service Commission**(E) Obligations of the Customer (Cont'd)

- (7) The customer must request and justify revalidation of all priority level assignments at least every three years.
- (8) Additionally, the NCS Manual 3-1-1, "Telecommunications Service Priority (TSP) System for National Security Emergency Preparedness (NSEP) Service User Manual", dated July 9, 1990 prescribes specific conditions which warrant NSEP Treatment and related procedures.

(F) Obligations of the Telephone Company

- (1) The Telephone Company will allocate resources to ensure best efforts to provide NSEP services by the time required.
- (2) The Telephone Company will work TSP System services in the order of their priority level assignments. The priority sequence is as follows:
- Restore NSEP services assigned restoration priority 1
 - Provision Emergency (E) NSEP services
 - Restore NSEP services assigned restoration priority 2, 3, 4 or 5
 - Provision NSEP services assigned provisioning priority 1, 2, 3, 4 or 5.
- (3) The Telephone Company will work cooperatively with other providers of NSEP service when only a portion is provided by the Telephone Company to ensure "end-to-end" service.
- (4) Additionally, TSP System service will be provided in accordance with the guidelines set forth in NCS Handbook 3-1-2, "Telecommunications Service Priority (TSP) System for National Security Emergency Preparedness (NSEP) Service Vendor Handbook" dated July 9, 1990.

(G) Rates and Charges

The following rates and charges are in addition to all other rates and charges that may apply for other services offered under this tariff which operate in conjunction with the TSP System.

(1) Establishment of TSP System Service

The establishment of TSP System service charge is a nonrecurring charge (NRC) specified in Section 6.4(G)(4) which applies when a FIA is ordered with provisioning and/or restoration priority. If both are ordered at the same time, only one NRC is applicable. The NRC is also applicable for orders changing priority levels.

FILED

AUG 01 2000

00 - 182

**MISSOURI
Public Service Commission**

FACILITIES FOR INTRASTATE ACCESS

RECEIVED6. MISCELLANEOUS SERVICES (Cont'd)

MAY 10 2000

6.4 Telecommunications Service Priority (TSP) System (Cont'd))MISSOURI
Public Service Commission(G) Rates and Charges (Cont'd)(2) Provisioning Priority

There are two basic levels of priority provisioning, Emergency (provisioning priority "E") and Essential (provisioning priority 1, 2, 3, 4 or 5).

(a) Emergency Provisioning

The Telephone company will take immediate action to provide the requested service at the earliest possible date. The rates and charges will apply as set forth in Section 10, Special Construction.

(b) Essential Provisioning

The Telephone Company will adjust its available resources to meet the customers requested due date. The rates and charges will apply as set forth in Section 3.2.2(E).

(3) Restoration Priority

Restoration Priority is a monthly rate per circuit for the ongoing administration and maintenance of the TSP System. This monthly rate only applies when a restoration priority code (1, 2, 3, 4 or 5) is specified in position 12 of the authorization code. The rates are specified in Section 6.4(G) (5).

FILED

AUG 01 2000

00-182
MISSOURI
Public Service Commission

Issued: May 10, 2000

Effective: August 1, 2000

FACILITIES FOR INTRASTATE ACCESS

RECEIVED

6. MISCELLANEOUS SERVICES (Cont'd)

MAY 10 2000

6.4 Telecommunications Service Priority (TSP) System (Cont'd)

(G) Rates and Charges (Cont'd)

MISSOURI
Public Service Commission

(4) Establishment of TSP System Service Charge

(USOC) Nonrecurring Charge
Per Circuit
(P1APX) (PR5PX) (PR8PX)
(P1ASX) (PR5SX) (PR8SX)

\$14.50

(5) Restoration Priority Rates

(USOC) Monthly Rate
Per Circuit
(PR9PX)
(PR9SX)

\$ 4.90

FILED

AUG 01 2000
00 - 182

MISSOURI
Public Service Commission

Issued: May 10, 2000

Effective: August 1, 2000

CANCELLED
October 19, 2009
Missouri Public
Service Commission
TN-2010-0092; YI-2010-0175

Kenneth Matzdorff
Chief Operating Officer
Kansas City, Missouri

FACILITIES FOR INTRASTATE ACCESS

RECEIVED

6. MISCELLANEOUS SERVICES (Cont'd)

MAY 10 2000

6.5 Balloting and Allocation Process For Equal Access

The Balloting and Allocation Process is an arrangement whereby:

MISSOURI
Public Service Commission

- An end user may select or be allocated to an interexchange carrier (IXC) to place intrastate, interLATA MTS/MTS-type calls without the 101XXXX access code. This IC is referred to as the end user's interLATA primary interexchange carrier (PIC).
- An end user may select or be allocated to an IC or local exchange carrier (LEC) to place intrastate, intraLATA MTS/MTS-type calls without the 101XXXX access code. This IC or LEC is referred to as the end user's intraLATA primary interexchange carrier (IPIC).

Balloting and allocation applies to agents of Public or Semipublic Pay Telephone service whereby the agent may select or be allocated to an IC to place intrastate interLATA calls without dialing the 101XXXX access code.

In the event that only one IC orders FGD or BSA-D to provide interLATA service or no IC or LEC orders FGD or BSA-D to provide intraLATA service from an end office in accordance with 3.1.1(D), the Balloting and Allocation Process for the PIC or IPIC set forth below will not apply.

On the effective date(s) of interLATA and intraLATA equal access (i.e., introduction of FGD or BSA-D in a serving end office), end users or agents who have not designated or been allocated to an IC or LEC will continue with the same IC or LEC service arrangement as existed prior to office conversion until the allocation process described in (B) occurs.

(A) End User and Agent Notification and Equal Access Balloting Process

(1) InterLATA Equal Access

End users and agents will be notified of the availability of equal access by means of an equal access ballot. ICs intending to participate in the Balloting Process for each serving end office must inform the Telephone Company in writing no later than 120 days prior to the end office conversion to FGD or BSA-D. The notification from ICs wishing to participate in pay telephone balloting must specify if the carrier will handle 0+ traffic only, both 0+ and 1+ traffic, or 0+ with 1+ traffic being handled by a secondary service provider. When 1+ coin traffic is handled by a secondary service provider, the participating IC must identify the secondary service provider. The initial ballot, the first of two ballots the end user and agent may receive, listing all ICs participating in the balloting process, and an explanation of equal access will be mailed to the end user and agent approximately 90 days prior to the end office conversion to FGD or BSA-D. IC names appearing on the ballot will be listed in a random fashion by end office to ensure that no IC will always appear first on the ballot. The IC listed on a pay telephone ballot will be the 0+ carrier.

Using the initial ballot, which end users and agents will be requested to return within 45 days after receipt, the end user or agent may designate an IC for all of its lines or may choose a different PIC for each of its lines. Where an end user has a multi-line hunt group and wants to designate several PICs for this hunt group, special arrangements may be made by contacting the Telephone Company.

An agent may designate an IC for the 0+ traffic from a pay telephone. The 1+ traffic from the pay telephone may be handled by the selected 0+ carrier if the carrier handles 1+ traffic, by a secondary service provider designated by the 0+ carrier, or by the default carrier if the 0+ carrier has made no arrangements with the Telephone Company to receive 1+ pay telephone traffic.

A second ballot will be sent to an end user or agent who has not designated an IC, either by return of the initial ballot or by appearing on an IC Customer list. The second ballot will be sent 30 days after conversion of the end office. If the end user or agent does not respond to the second ballot by the requested date, then that end user or agent will be assigned to the allocated IC shown on the second ballot.

FILED

Issued: May 10, 2000

Effective: August 1, 2000

CANCELLED
October 19, 2009
Missouri Public
Service Commission
TN-2010-0092; YI-2010-0175

Kenneth Matzdorff
Chief Operating Officer
Kansas City, Missouri

AUG 01 2000
- 182
MISSOURI
Public Service Commission

RECEIVED

FACILITIES FOR INTRASTATE ACCESS

MAY 10 2000

6. MISCELLANEOUS SERVICES (Cont'd)

6.5 Balloting and Allocation Process For Equal Access (Cont'd)

**MISSOURI
Public Service Commission**

(A) End User and Agent Notification and Equal Access Balloting Process (Cont'd)

(2) IntraLATA Equal Access*

When intraLATA and interLATA equal access is made available concurrently, end users and agents will be notified of the availability of equal access by means of an equal access ballot. ICs and LECs intending to participate in the Balloting Process for each serving end office must inform the Telephone Company in writing no later than 120 days prior to the end office conversion to FGD or BSA-D. The initial ballot, the first of two ballots the end user and agent may receive, listing all ICs and LECs participating in the balloting process, and an explanation of equal access will be mailed to the end user and agent approximately 90 days prior to the end office conversion to FGD or BSA-D. IC and LEC names appearing on the ballot will be listed in a random fashion by end office to ensure that no IC or LEC will always appear first on the ballot.

Using the initial ballot, which end users and agents will be requested to return within 45 days after receipt, the end user or agent may designate an IC or LEC for all of its lines or may choose a different IPIC for each of its lines. Where an end user has a multi-line hunt group and wants to designate several IPICs for this hunt group, special arrangements may be made by contacting the Telephone Company.

A second ballot will be sent to an end user or agent who has not designated an IC or LEC, either by return of the initial ballot or by appearing on an IC or LEC Customer list. The second ballot will be sent 30 days after conversion of the end office. If the end user or agent does not respond to the second ballot by the requested date, then that end user or agent will be assigned to the allocated IC or LEC shown on the second ballot.

When intraLATA equal access is made available in an end office at some time after the end office has converted to interLATA equal access, the Balloting and Allocation process for the intraLATA IPIC will not apply.

(3) Exceptions to IntraLATA Equal Access

Per Report and Order issued June 20, 1997, in Case No. TT-96-398, IntraLATA Equal Access will not be implemented in Community Optional Service (COS) target exchanges and their associated Extended Area Service (EAS) exchanges pending a decision in Case No. TW-97-333. The COS target exchanges and associated EAS exchanges are as follows:

- | | |
|----------------|--------------|
| Aurora | Paris |
| Houston | Potosi |
| Ironton | Raymondville |
| Milo | Roby |
| Monroe City | Shelbina |
| Mount Vernon | Van Buren |
| Mountain Grove | |

FILED

AUG 01 2000

00 - 182

**MISSOURI
Public Service Commission**

* IntraLATA equal access will be available for end offices based on the Company's Missouri IntraLATA Conversion Schedule.

FACILITIES FOR INTRASTATE ACCESS

RECEIVED

6. MISCELLANEOUS SERVICES (Cont'd)

MAY 10 2000

6.5 Balloting and Allocation Process For Equal Access (Cont'd)**MISSOURI
Public Service Commission**(B) Allocation Process

An IC or LEC must notify the Telephone Company of its intent to participate in the allocation process 52 days prior to the end office conversion to equal access. The IC or LEC must also identify whether it will participate in the allocation of business lines, residence lines, or Public/Semipublic Pay Telephones or any combination.

The Telephone Company will tabulate the initial ballots received from the end users and agents described in 6.5(A) and the IC and LEC Customer lists described in 6.5(C). The percentage of end users and agents who have selected a participating IC or LEC will be determined from these ballots and lists. These percentages will be used for the allocation of end users and agents who did not respond to the initial ballot or appear on an IC or LEC list. The percentages used for allocation will be determined approximately five days after end office conversion. A second ballot, indicated in 6.5(A), will be sent to end users and agents who have been allocated to an IC or LEC.

Separate allocation processes will be used for residence, business and Public and Semipublic Pay Telephone lines. The number of end users and agents designating an IC or LEC by returning the initial ballot or appearing on an IC or LEC end user and/or agent list will be totaled. This total will be utilized to compute the percentages used for allocation of residence and business Customers and Public/Semipublic Pay Telephone Customers.

If an IC or LEC participating in the ballot process notifies the Telephone Company that it does not wish to participate in the allocation process, the percentage of Customers allocable to that nonparticipating IC or LEC will be allocated to the remaining ICs and LECs.

(C) Interexchange Carrier Customer Lists

The Telephone Company will accept IC and LEC customer lists identifying end users and agents who have made individual arrangements with the IC or LEC to designate the IC or LEC as their primary long distance carrier. The list should be in the form of magnetic tape or paper printout. IC and LEC lists may continue to be received after the initial ballot deadline. All lists must be submitted to the Telephone Company up to no later than 20 days prior to the end office conversion to be included in the allocation process. If end user and agent ballots are received by the IC or LEC, the end user and agent will be included in the IC or LEC customer list. The IC or LEC must retain the actual ballots for inspection by the Telephone Company for a period of one year after end office conversion.

FILEDAUG 01 2000
00-182**MISSOURI
Public Service Commission**

FACILITIES FOR INTRASTATE ACCESS

RECEIVED

6. MISCELLANEOUS SERVICES (Cont'd)

MAY 10 2000

6.5 Balloting and Allocation Process For Equal Access (Cont'd)

MISSOURI
Public Service Commission

(D) End User Choice Discrepancy

An IC or LEC is required to certify at the time it submits end user and/or agent lists to the Telephone Company that it has on file, or has instituted steps designed to obtain signed letters of agency or confirmations of choice from the end user or agent. The IC or LEC is not required to submit letters of agency when submitting end user or agent lists to the Telephone Company, but should maintain the confirmations or letters on file for use in dispute resolution. The IC or LEC should request written confirmation of choice from its Customers no later than the date of submission of its first bill to the Customer.

When an end user or agent indicates more than one PIC or IPIC per line or returns an illegible ballot, the Telephone Company will contact the end user or agent for clarification.

When the Telephone Company identifies a conflict between a ballot and an IC or LEC list, or between lists submitted by two or more ICs and/or LECs, the Telephone Company will notify, within 10 days, all affected ICs and LECs via a conflict report. Those ICs and LECs not involved in any conflicts will receive a zero conflict report from the Telephone Company.

When an end user or agent returns a ballot to the Telephone Company and also appears on a conflicting IC or LEC Customer list, the ballot takes precedence. If an end user or agent appears on two or more IC or LEC Customer lists, the end user or agent will be allocated along with the nonrespondents to the initial ballot. A letter sent with the second ballot will inform the end user or agent that there exists a conflict between two or more ICs and/or LECs and a selection must be made by the deadline of the second ballot, unless the allocated IC or LEC indicated is the end user's or agent's choice.

FILED

AUG 01 2000
00-182

MISSOURI
Public Service Commission

Issued: May 10, 2000

Effective: August 1, 2000

CANCELLED
October 19, 2009
Missouri Public
Service Commission
TN-2010-0092; YI-2010-0175

Kenneth Matzdorff
Chief Operating Officer
Kansas City, Missouri

RECEIVED

FACILITIES FOR INTRASTATE ACCESS

MAY 10 2000

6. MISCELLANEOUS SERVICES (Cont'd)

6.5 Balloting and Allocation Process For Equal Access (Cont'd)

**MISSOURI
Public Service Commission**

(E) Balloting and Allocation Procedure for Public and Semipublic Pay Telephones

The balloting and allocation process is a procedure whereby an agent of Public and Semipublic Pay Telephone service may select and designate to the Telephone Company an IC to access, without dialing an access code, for 0+ interLATA calls. This IC is referred to as the agent's primary IC. The 1+ interLATA calls from a pay telephone will be handled by the agent's primary IC if the IC handles 1+ traffic, by a secondary service provider selected by an agent's primary IC, or by the default carrier if the agent's primary IC has made no arrangements for handling 1+ traffic from a pay telephone.

If the agent's primary IC elects not to submit an order for its 1+ interLATA sent-paid traffic or fails to select a secondary service provider to handle its 1+ interLATA calls from the Telephone Company's pay telephones, the 1+ interLATA coin sent-paid traffic will continue to be routed to the existing 1+ default carrier (provided such carrier continues to accept it) until the 0+ carrier notifies the Telephone Company.

The Telephone Company will notify agents of Public and Semipublic Pay Telephones of the availability of equal access through the mailing of an Equal Access Ballot. The mailing of the initial ballots will take place 90 days prior to conversion.

Agents of Public and Semipublic Pay Telephones will be requested to return their respective ballot to the Telephone Company within 45 days from receipt of the ballot.

An IC obtaining service commitments from agents directly, must obtain signed authorization from those agents. The IC will be required to provide that authorization to the Telephone Company within 15 days of the Telephone Company's request for the resolution of disputes.

Agents of Public and Semipublic Pay Telephones who have not made a primary IC selection, either through the Payphone Equal Access Ballot, or directly with an IC, will be sent a second ballot by the Telephone Company 30 days after the conversion date.

The Telephone Company will tabulate the initial ballots received from the agents and the IC customer lists. The percentage of agents who have selected a participating IC will be determined from these ballots and lists. These percentages will be used for the tentative allocation of agents who did not respond to the initial ballot or appear on an IC list. The percentages used for allocation will be determined approximately five days after end office conversion.

If an IC participating in the ballot process notifies the Telephone Company that it does not wish to participate in the allocation process, the percentage of customers allocable to that nonparticipating IC will be allocated to the remaining ICs.

The Telephone Company will make post conversion changes in a Public and/or Semipublic Pay Telephone agent's PIC assignment pursuant to an IC provided list. Should an agent dispute authorization for an IC submitted change within 90 days of the PIC assignment to the IC, and if the IC cannot produce a letter of agency or confirmation of choice from the agent within 30 days of a request by the Telephone Company to do so, the Telephone Company will place the public or semipublic telephone on the agent's previously selected IC network. The IC will be billed one unauthorized PIC change charge in 6.5(M) for the change to the disputed network and one PIC change charge in 6.5(L) for returning the public or semipublic telephone to its originally selected IC network.

If the IC produces the letter of agency of confirmation of choice within 30 days of the request by the Telephone Company to do so, and if the service of the disputing agent has been switched back to its originally selected IC network, the agent will be billed two PIC change charges in 6.5(L) in lieu of charges to the IC, one for the switch to the IC providing the letter of agency or confirmation of choice and one for the subsequent switch back to the agent's original IC.

FILED

Issued: May 10, 2000

Effective: August 1, 2000

CANCELLED
October 19, 2009
Missouri Public
Service Commission
TN-2010-0092; YI-2010-0175

Kenneth Matzdorff
Chief Operating Officer
Kansas City, Missouri

AUG 01 2000
07-182
**MISSOURI
Public Service Commission**

RECEIVED

FACILITIES FOR INTRASTATE ACCESS

6. MISCELLANEOUS SERVICES (Cont'd)

MAY 10 2000

6.5 Balloting and Allocation Process For Equal Access (Cont'd)(F) PIC and IPIC Charge Application

Initial end user, end user agent and a local service provider that has been selected (herein referred to as reseller) selection of a PIC by ballot or appearing on an IC or, for intraLATA service, a LEC list will not incur a charge. A change of PIC selection prior to the end office conversion to interLATA equal access will not incur a charge. A change of IPIC selection prior to the end office conversion to intraLATA equal access will not incur a charge. Notification of a change in a PIC or IPIC may be coordinated by the end user, end user agent or reseller with either the IC or LEC selected or with the Telephone Company, if it is not the selected LEC. Within six months after conversion to equal access, an end user allocated to an IC or LEC may elect to change to another IC or LEC at no charge, on a one-time basis. After the six month period has elapsed, a nonrecurring charge in 6.5(L) will apply to change the PIC or IPIC. If the customer changes both the PIC and IPIC on the same order, two charges will apply. After conversion to equal access, end users, end user agents and resellers who select an IC or LEC by returning the initial ballot will be charged for each change made.

MISSOURI
Public Service Commission

In end offices converted to Equal Access new end users, end user agent's and reseller's of Pay Telephones and multi-party end users who upgrade to individual lines must presubscribe to the PIC and/or IPIC of their choice at the time an order is placed for service. The IPIC may be an IC or LEC (the Telephone Company or another LEC). Upon the end user, end user agent's or reseller's selection of the PIC and/or IPIC, at the time of placing an order, a confirmation notice will be sent identifying the IC selected as the PIC and/or the IC or LEC selected as the IPIC. From the date of the confirmation notice, he will have 90 days to change his prescription selection without a charge. If a PIC and/or IPIC is not chosen at the time the order for service is submitted, the end user, end user agent or reseller will be sent a confirmation notice which contains a list of ICs with FGD or BSA-D providing interLATA service and/or a list of ICs and LECs providing intraLATA service, and will be informed that they have 90 days to contact the IC and/or LEC of their choice or the Telephone Company to apply for the PIC or IPIC arrangement. If notice is received by the Telephone Company within 90 days of the in-service date for local service or upgrade, no charge will be billed to the end user, end user agent or reseller. If notice is received after 90 days, the end user, end user agent or reseller will be billed a nonrecurring charge for each PIC or IPIC as in 6.5(L). Until the end user, end user agent or reseller receives service from the selected carrier, he may access the carrier of his choice by dialing the appropriate 101XXXX carrier identification code.

The Telephone Company will make post conversion changes in the end user's, end user agent's or reseller's PIC or IPIC assignment pursuant to an IC or LEC provided list of Customers, accepted by the Telephone Company under conditions in (C) and (D). Post conversion changes in a PIC assigned to a Public or Semipublic Pay Telephone will be made under the conditions set forth in 6.5(E). Should an end user, end user agent or reseller dispute authorization of the change within 90 days of the PIC or IPIC assignment, and if the carrier cannot produce a letter of agency or confirmation from the end user, end user agent or reseller, the Telephone Company will place the end user on the previous carrier network where possible and the carrier will be billed according to the following options:

- (1) If the IC or LEC has previously submitted a letter requesting the Telephone Company to settle end user disputes without investigation, the carrier will be charged two PIC or IPIC change charges, in 6.5(L). One PIC or IPIC change charge is for the change to the disputed carrier and one is for placing the end user on his previous carrier network or the carrier network of his choice. By virtue of the carrier's letter requesting no investigation, the Telephone Company will perform no investigation and will not accept nor request at a later date any letter of authorization regarding an end user's disputed PIC or IPIC assignment. This option does not apply to Pay telephones nor Coinless telephone lines. This option also does not relieve the IC or LEC of the conditions set forth in (C) and (D) preceding.
- (2) If the IC or LEC does request in writing that end user PIC or IPIC disputes be resolved with investigation as in (1) preceding, the carrier will be billed one Unauthorized PIC or IPIC charge, in 6.5(M), for the change to the disputed carrier and one PIC or IPIC change charge, in 6.5(L), for placing the end user on the carrier network of his choice.

FILED

Issued: May 10, 2000

Effective: August 1, 2000

Kenneth Matzdorff
Chief Operating Officer
Kansas City, Missouri

AUG 01 2000

00 - 182

MISSOURI
Public Service Commission

FACILITIES FOR INTRASTATE ACCESS

RECEIVED

MAY 10 2000

6. MISCELLANEOUS SERVICES (Cont'd)

6.5 Balloting and Allocation Process For Equal Access (Cont'd)MISSOURI
Public Service Commission(F) PIC and IPIC Charge Application (Cont'd)

If, under (2) preceding, the carrier produces the letter of agency or confirmation of choice within 30 days of the Telephone Company request, the end user, end user agent or reseller will be billed two PIC or IPIC charges in 6.5(L) in lieu of charges to the carrier. Charges are only applicable if a change in an end user's, end user agent's or reseller's carrier selection has actually been implemented in the switch.

(G) Multi-party End Users

Multi-party end users will continue with the same IC service arrangement which existed prior to the end office conversion. However, multi-party end users may access the IC of their choice by dialing the appropriate 101XXXX carrier identification code. In certain suitably equipped end offices two-party customers may subscribe to the IC of their choice.

(H) Cancellation of a Carrier Participation

If an IC or LEC cancels all of its FGD or BSA-D service in the converting end office prior to the conversion date or discontinues all of its FGD or BSA-D service within two years after the introduction of FGD or BSA-D in the converting end office, the carrier is obligated to do the following:

- (1) Notify the Telephone Company of the cancellation of their FGD or BSA-D service, and
- (2) Contact in writing all end users, end user agents and resellers who have selected, or been allocated to, the canceling carrier as their PIC or IPIC, inform these end users, end user agents and resellers of the cancellation, request the end users, end user agents and resellers to select a new PIC or IPIC, and state that the canceling carrier will pay the nonrecurring charge as set forth in 6.5(L).

The Telephone Company will bill the canceling IC or LEC for a period of two years from the discontinuance of FGD or BSA-D service, the nonrecurring charge as set forth in 6.5(L) for each end user, end user agent and reseller this carrier has currently designated to it. Such charge will not apply to the canceling carrier where the canceling IC or LEC transfers or assigns its FGD or BSA-D services and the associated 101XXXX code to another carrier in such manner that the Telephone Company does not change end user, end user agents or resellers records or if another carrier elects to pay nonrecurring charge on behalf of the canceling IC or LEC.

(I) Liability of the Telephone Company

If through the fault of the Telephone Company, the end user, end user agent or reseller is not subscribed to its chosen PIC or IPIC, the nonrecurring charges in 6.5(L) and 6.5(M) do not apply to reassign the end user, end user agent or reseller to his chosen PIC or IPIC.

(J) (Reserved for Future Use)

(K) Carrier Desired Due Date (ICDDD) for PIC or IPIC Installation

An IC or LEC may request a desired due date for PIC or IPIC installation for a specific, single end user, end user agent or reseller acting on behalf of an end user post equal access conversion. This ICDDD is a mutually agreed upon negotiated due date, determined to be between 3 and 45 business days from the date of receipt of the order. The carrier must coordinate the ICDDD with the Telephone Company prior to sending in the first order.

The ICDDD does not apply to routine lists provided by the carrier, as set forth in 6.5(C) and (D). The Nonrecurring Charge for PIC or IPIC as set forth in 6.5(L), applies to each line converted to the carrier requesting ICDDD. This charge will be billed to the carrier's end user customer.

FILED

Issued: May 10, 2000

Effective: AUG 01 2000

CANCELLED
October 19, 2009
Missouri Public
Service Commission
TN-2010-0092; YI-2010-0175

Kenneth Matzdorff
Chief Operating Officer
Kansas City, Missouri

00-182
MISSOURI
Public Service Commission

RECEIVED

FACILITIES FOR INTRASTATE ACCESS

MAY 10 2000

6. MISCELLANEOUS SERVICES (Cont'd)

6.5 Balloting and Allocation Process For Equal Access (Cont'd)

MISSOURI
Public Service Commission

(L) Nonrecurring Charge for Primary InterLATA Carrier (PIC) or Primary IntraLATA Carrier (IPIC)

The nonrecurring charge for PIC* or IPIC is as follows:

<u>GSEC</u>	<u>Nonrecurring Charge</u>	
Per Telephone Company Local Service Line or Trunk	\$ 3.92	NAAPS (IPIC)

(M) Nonrecurring Charge for Unauthorized PIC or IPIC changes

The nonrecurring charges for Unauthorized PIC or IPIC changes are as follows:

<u>GSEC</u>	<u>Nonrecurring Charge</u>	
(1) Per Telephone Company Local Business or Residence Service Line or Trunk	\$13.73	NEPSUBR (PIC) NAAPSUBR (IPIC)

FILED

AUG 01 2000
00-182

MISSOURI
Public Service Commission

* The InterLATA PIC charge will be billed the rate as filed in National Exchange Carrier Association (NECA) Tariff FCC No. 5.

Issued: May 10, 2000

Effective: August 1, 2000

Kenneth Matzdorff
Chief Operating Officer
Kansas City, Missouri

CANCELLED
October 19, 2009
Missouri Public
Service Commission
TN-2010-0092; YI-2010-0175

FACILITIES FOR INTRASTATE ACCESS

RECEIVED

MAY 10 2000

6. MISCELLANEOUS SERVICES (Cont'd)

6.6 Additional Testing

MISSOURI Public Service Commission

The Telephone Company will perform acceptance testing as specified in 4.2.1 and 4.2.2 preceding to insure that FIA ordered by the customer are functioning properly, prior to turning over such FIA to the customer. In addition, the Telephone Company will perform ongoing tests as specified in 4.2.1 and 4.2.2 to assure the continued satisfactory performance of Switched Access Services ordered by the customer.

Testing offered under this section of the tariff is in addition to those tests described above and will be provided, when requested by the customer, at an additional charge.

Testing is provided by Telephone Company personnel at Telephone Company locations. However, provisions are made in 6.6(A)(5) and 6.6(B)(2), to allow a customer to request Telephone Company personnel to perform testing at the customer designated location or the end user premises.

Additional testing is provided on a scheduled or nonscheduled basis. Scheduled testing shall be performed on a predetermined time basis to allow for cost efficient utilization of Telephone Company and customer resources. Scheduled testing should be based on a one year period. Nonscheduled tests are performed by the Telephone Company on a request-by-request basis, not in conjunction with any fixed schedule.

The offering of testing under this section of the tariff is made subject to the availability of the necessary qualified personnel and test equipment at the various test locations mentioned in (A), (B), and (C) following.

FILED

AUG 01 2000
00-182

MISSOURI Public Service Commission

Issued: May 10, 2000

Effective: August 1, 2000

CANCELLED
October 19, 2009
Missouri Public
Service Commission
TN-2010-0092; YI-2010-0175

Kenneth Matzdorff
Chief Operating Officer
Kansas City, Missouri

FACILITIES FOR INTRASTATE ACCESS

RECEIVED

6. MISCELLANEOUS SERVICES (Cont'd)

MAY 10 2000

6.6 Additional Testing (Cont'd)

**MISSOURI
Public Service Commission**(A) Switched Access Testing

Testing for Switched Access is comprised of (a) tests which are performed during the installation of Switched Access (i.e., acceptance tests) and (b) tests which are performed after acceptance of such Switched Access by a customer (i.e., in-service tests).

These tests are performed on a scheduled or nonscheduled basis, and may be conducted on an automatic, cooperative, or manual basis, as defined in (1), (2), (3), (4), and (5) following.

(1) Additional Cooperative Acceptance Testing

Additional Cooperative Acceptance Testing (ACAT) of Switched Access involves the Telephone Company provision of a technician at its office(s) and the customer provision of a technician at its CDL, with suitable test equipment to perform the required tests.

Additional Cooperative Acceptance Testing may apply when the customer requests additional tests not specified in 4.2.7.

The labor charges as set forth in 6.2(G) will apply to Additional Cooperative Acceptance Testing at the appropriate Basic, Overtime, or Premium rate.

(2) Automatic Scheduled Testing

Automatic Scheduled Testing (AST) of FGB, FGC, FGD, BSA-B, BSA-C, BSA-D and SAC Access Service, is provided, as specified in 4.2.1 and 4.2.2, where the customer provides remote office test lines and 105 test lines with associated responders or their functional equivalent. AST charges will apply when such testing is requested on a more frequent basis than is provided for in accordance with the Telephone Company's Central Office Maintenance Planning System (COMPS). The customer may specify a more frequent schedule of tests at least sixty days prior to the start of the prescribed schedule. Trunks from a Telephone Company digital switch, to a customer digital switch, utilizing digital facilities, are excluded from mandatory routine testing. The rates, as in 6.6(C), will apply to additional AST.

FILED

AUG 01 2000

QU-182

**MISSOURI
Public Service Commission**

Issued: May 10, 2000

Effective: August 1, 2000

FACILITIES FOR INTRASTATE ACCESS

RECEIVED

6. MISCELLANEOUS SERVICES (Cont'd)

MAY 10 2000

6.6 Additional Testing (Cont'd)

MISSOURI
Public Service Commission

(A) Switched Access Testing (Cont'd)

(2) Automatic Scheduled Testing (Cont'd)

The Telephone Company will provide a monthly AST report that lists the trunks within each Central Office access group that failed to meet established requirements. Trunk test failures requiring customer participation for trouble resolution will be provided to the customer on an as-occurs basis. A monthly report that lists the test results will be provided to the customer.

(3) Additional Cooperative Scheduled Testing

Additional Cooperative Scheduled Testing (ACST) of FGA, FGB, FGC, FGD, BSA-A, BSA-B, BSA-C, BSA-D and SAC Access Service occurs when the Telephone Company provides a technician at its office(s) and the customer provides a technician at its customer designated location, with suitable test equipment to perform the required tests. ACST charges will apply when loss/noise/balance testing or gain-slope testing is requested on a more frequent basis than is provided for in accordance with the Telephone Company's Central Office Maintenance Planning System (COMPS). ACST charges also apply when additional tests are requested for FGA, FGB, FGC, FGD, BSA-A, BSA-B, BSA-C, BSA-D and SAC Access Service that are not specified in 4.2.1 and 4.2.2. The customer may specify a more frequent schedule of tests sixty days prior to the start of the prescribed schedule. The rates, as set forth in 6.6(C), will apply for additional ACST.

The Telephone Company will provide, on a quarterly basis, an ACST report that lists the test results and the number of trunks that passed or failed. Trunk test failures requiring customer participation for trouble resolution will be provided to the customer on an as-occurs basis.

FILED

AUG 01 2000
00-182

MISSOURI
Public Service Commission

Issued: May 10, 2000

Effective: August 1, 2000

CANCELLED
October 19, 2009
Missouri Public
Service Commission
TN-2010-0092; YI-2010-0175

Kenneth Matzdorff
Chief Operating Officer
Kansas City, Missouri

FACILITIES FOR INTRASTATE ACCESS

RECEIVED

6. MISCELLANEOUS SERVICES (Cont'd)

MAY 10 2000

6.6 Additional Testing (Cont'd)

**MISSOURI
Public Service Commission**(A) Switched Access Testing (Cont'd)(4) Additional Manual Scheduled Testing

Additional Manual Scheduled Testing (AMST) of FGA, FGB, FGC, FGD, BSA-A, BSA-B, BSA-C, BSA-D or SAC Access Service occurs when the Telephone Company provides a technician at its office(s) and at the customer designated location. AMST charges will apply when loss/noise/balance testing or gain-slope testing is requested on a more frequent basis than is provided for in accordance with the Telephone Company's Central Office Maintenance Planning System (COMPS). AMST charges also apply when additional tests are requested for FGA, FGB, FGC, FGD, BSA-A, BSA-B, BSA-C, BSA-D or SAC Access Service that are not specified in 4.2.1 or 4.2.2. The customer may specify a more frequent schedule of tests sixty days prior to the start of the prescribed schedule. The rates as in 6.6(C) will apply to additional AMST.

The Telephone Company will provide, on a quarterly basis, an AMST report that lists the test results and the number of trunks that passed or failed. Trunk test failures requiring customer participation for trouble resolution will be provided to the customer on an as-occurs basis.

(5) Nonscheduled Testing

Nonscheduled Testing (NST) will be performed "on demand" which results in the measurement of Switched Access. NST charges will apply only when testing is requested more frequently than is provided for in accordance with COMPS, or when a specific test is requested that is not normally performed. Tests for Switched Access which are normally performed are contained in 4.2.1 and 4.2.2. Nonscheduled Testing (NST) of Switched Access may consist of the following testing arrangements:

- the customer provides remote office test lines and 105 test lines with associated responders or their functional equivalent (automatic testing), or
- the Telephone Company provides a technician at its office(s) and the customer provides a technician at its customer designated location with suitable test equipment to perform the required tests (cooperative testing), or
- the Telephone Company provides a technician at its office(s), and at the customer designated location or end user premises with suitable test equipment to perform the required tests (manual testing).

FILED

AUG 01 2000

00 - 182

MISSOURI

Public Service Commission

Issued: May 10, 2000

Effective: August 1, 2000

CANCELLED
October 19, 2009
Missouri Public
Service Commission
TN-2010-0092; YI-2010-0175

Kenneth Matzdorff
Chief Operating Officer
Kansas City, Missouri

FACILITIES FOR INTRASTATE ACCESS

RECEIVED

6. MISCELLANEOUS SERVICES (Cont'd)

MAY 10 2000

6.6 Additional Testing (Cont'd)

**MISSOURI
Public Service Commission**

(A) Switched Access Testing (Cont'd)

(5) Nonscheduled Testing (Cont'd)

Nonscheduled Tests may consist of any tests which the customer may require. The rates as set forth in 6.6(C) following will apply to Nonscheduled Automatic Testing. The labor charges as set forth in 6.2(G) preceding will apply to Nonscheduled Cooperative and Manual FIA Testing at the appropriate Basic, Overtime, or Premium rate.

If nonscheduled tests are required and trouble is found in GTOC facilities, charges for testing the GTOC facilities will not apply. If, however, trouble is found in the customer equipment, charges as set forth in 6.6(C) following and labor charges as set forth in 6.2(G) preceding are applicable.

FILED

AUG 01 2000

00 - 182

**MISSOURI
Public Service Commission**

Issued: May 10, 2000

Effective: August 1, 2000

CANCELLED
October 19, 2009
Missouri Public
Service Commission
TN-2010-0092; YI-2010-0175

Kenneth Matzdorff
Chief Operating Officer
Kansas City, Missouri

FACILITIES FOR INTRASTATE ACCESS

RECEIVED

6. MISCELLANEOUS SERVICES (Cont'd)

MAY 10 2000

6.6 Additional Testing (Cont'd)

MISSOURI Public Service Commission

(A) Switched Access Testing (Cont'd)

(6) Obligations of the Customer

- (a) The customer shall provide the Remote Office Test Line priming data to the Telephone Company, as appropriate, to support AST as set forth in 6.6(A)(2) preceding or NST as set forth in 6.6(A)(5) preceding.
- (b) The customer shall make the facilities to be tested available to the Telephone Company at times mutually agreed upon.

(B) Special Access Testing

The Telephone Company will, at the request of a customer, provide assistance in performing specific tests requested by the customer, however, the Telephone Company will only perform maintenance testing for its facilities within the LATA.

(1) Additional Cooperative Acceptance Testing

When a customer provides a technician at its customer designated location or at the end user premises, with suitable test equipment to perform the required tests, the Telephone Company will provide a technician at its office for the purpose of conducting Additional Cooperative Acceptance Testing (ACAT). The labor charges as set forth in 6.2(G) preceding will apply to ACAT at the appropriate Basic, Overtime, or Premium rate.

Additional Cooperative Acceptance Testing charges will apply when the customer requests tests which are not required to meet the transmission performance parameters as set forth in the GTE Technical Interface Reference Manual.

(2) Nonscheduled Testing

When a customer provides a technician at its customer designated location or at the end user premises, with suitable test equipment to perform the required tests, the Telephone Company will provide a technician at its office (cooperative testing) for the purpose of conducting Nonscheduled Testing (NST). Nonscheduled testing may consist of any test (e.g., loss, noise, slope, envelope delay, etc.) which the customer may request. If such testing indicates trouble in Telephone Company facilities, then the customer will not be charged. NST charges will apply if the trouble is in the facilities of the customer. At the customer's request, the Telephone Company will provide a technician at the customer designated location or at the end user premises (manual testing). The labor charges as set forth in 6.2(G) preceding will apply to Nonscheduled Testing at the appropriate Basic, Overtime, or Premium rate.

FILED

AUG 01 2000

00-182 MISSOURI

Public Service Commission Effective: August 1, 2000

Issued: May 10, 2000

CANCELLED
October 19, 2009
Missouri Public
Service Commission
TN-2010-0092; YI-2010-0175

Kenneth Matzdorff
Chief Operating Officer
Kansas City, Missouri

FACILITIES FOR INTRASTATE ACCESS

RECEIVED

6. MISCELLANEOUS SERVICES (Cont'd)

MAY 10 2000

6.6 Additional Testing (Cont'd)

**MISSOURI
Public Service Commission**

(B) Special Access Testing (Cont'd)

(3) Obligation of the Customer

When the customer subscribes to Testing as set forth in this section, the customer shall make the facilities to be tested available to the Telephone Company at times mutually agreed upon.

FILED

AUG 01 2000
00 - 182

**MISSOURI
Public Service Commission**

Issued: May 10, 2000

Effective: August 1, 2000

CANCELLED
October 19, 2009
Missouri Public
Service Commission
TN-2010-0092; YI-2010-0175

Kenneth Matzdorff
Chief Operating Officer
Kansas City, Missouri

FACILITIES FOR INTRASTATE ACCESS

RECEIVED

6. MISCELLANEOUS SERVICES (Cont'd)

MAY 10 2000

6.6 Additional Testing (Cont'd)

MISSOURI Public Service Commission

(C) Rates and Charges

(1) Automatic Scheduled Testing

Basic Offering to First Point of Switching
Per Transmission Path, Per Month

(USOC)

Rate
(UBGXT)

\$ 0.45

(2) Additional Cooperative Scheduled Testing

Basic Offering to First Point of Switching
Per Transmission Path, Per Month

(USOC)

Rate
(UBSXT)

\$1.57

Gain-Slope-To First Point of Switching
Per Transmission Path, Per Month

(USOC)

Rate
(UBSXD)

\$ 0.67

(3) Additional Manual Scheduled Testing

Basic Offering to First Point of Switching
Per Transmission Path, Per Month

(USOC)

Rate
(UBMXT)

\$3.14

Gain-Slope-To First Point of Switching
Per Transmission Path, Per Month

(USOC)

Rate
(UBMXD)

\$1.34

FILED

AUG 01 2000

00 - 182

MISSOURI Public Service Commission

Issued: May 10, 2000

Effective: August 1, 2000

CANCELLED
October 19, 2009
Missouri Public
Service Commission
TN-2010-0092; YI-2010-0175

Kenneth Matzdorff
Chief Operating Officer
Kansas City, Missouri

FACILITIES FOR INTRASTATE ACCESS

RECEIVED

6. MISCELLANEOUS SERVICES (Cont'd)

MAY 10 2000

6.7 (Reserved for Future Use)

**MISSOURI
Public Service Commission**

FILED

AUG 01 2000

00-182

**MISSOURI
Public Service Commission**

Issued: May 10, 2000

Effective: August 1, 2000

CANCELLED
October 19, 2009
Missouri Public
Service Commission
TN-2010-0092; YI-2010-0175

Kenneth Matzdorff
Chief Operating Officer
Kansas City, Missouri

FACILITIES FOR INTRASTATE ACCESS

RECEIVED

6. MISCELLANEOUS SERVICES (Cont'd)

MAY 10 2000

6.8 End User/Agent Lists

MISSOURI Public Service Commission

(A) Presubscription List

(1) InterLATA Equal Access

Prior to conversion to equal access (i.e., introduction of FGD or BSA-D in an end office switch) an IC may request a list of the Telephone Company's end users of record served from that end office switch. The Presubscription List will be provided as follows:

- (a) The Telephone Company will provide a list from its customer data base. The list may be provided on magnetic tape, electronic transmission or paper printout, at the option of the IC, at rates provided in 6.8.1(A). Foreign listings, PBX stations, CU Centrex stations and numbers not in service will not be provided.
 - (1) The initial list will be provided to the IC no later than 30 days after receipt of the order and payment by the IC of charges as in 6.8.1(A). The nonrecurring charge for the initial list applies per order. A single order may contain all end offices within a state having the same equal access conversion date. The telephone number will not be provided if an end user has a nonpublished number.
 - (2) The Account Activity List, which includes a listing of all changes to the customer data base, since the initial list was produced, will be provided on a cyclic basis. The Account Activity List will only include information for those end users and agents that are presubscribed to the IC (including end users with nonpublished numbers) for the sole purpose of updating the IC's customer account information. There is no charge for this list.
- (b) The IC agrees to use the Initial and Account Activity Lists for the sole purpose of either contacting potential customers, or existing customers, regarding interexchange telecommunications services available through equal access to be obtained from the Telephone Company or for the purpose of updating IC customer account information. The IC agrees not to sell, or reproduce in any manner, in whole or in part, the lists or permit such to be done.
- (c) The IC shall indemnify, protect and save harmless the Telephone Company from and against any and all loss, liability, damages and expense arising out of any demand, claim, suit or judgment for damages which may arise out of the Telephone Company's supplying of listing information, services or records.
- (d) The Telephone Company and the IC agree that the mutual objective of the parties is to conduct their respective businesses to avoid confusion by the end users as to the separate and independent identity of the respective companies and their services. Neither the Telephone Company nor the IC shall make any representation to end users, the public, prospective advertisers, expressed or implied, written or oral, which would imply that the IC is the same as, a part of, or associated with the Telephone Company.
- (e) This service may be terminated by either the Telephone Company or the IC upon thirty (30) days' written notice. The Telephone Company reserves the right to terminate this service immediately upon written notice if the IC misuses the list information. Performance by the Telephone Company shall be excused in the event of strike, riot, act of God or any other cause beyond the reasonable control of the Telephone Company.

FILED

Issued: May 10, 2000

Effective: August 1, 2000

AUG 01 2000 00 - 182

MISSOURI Public Service Commission

CANCELLED
October 19, 2009
Missouri Public
Service Commission
TN-2010-0092; YI-2010-0175

Kenneth Matzdorff
Chief Operating Officer
Kansas City, Missouri

FACILITIES FOR INTRASTATE ACCESS

RECEIVED

6. MISCELLANEOUS SERVICES (Cont'd)

MAY 10 2000

6.8 End User/Agent Lists (Cont'd)

**MISSOURI
Public Service Commission**(A) Presubscription List (Cont'd)(2) IntraLATA Equal Access

Prior to conversion to intraLATA equal access an IC or LEC may request a list of the Telephone Company's end users and agents of record served from that end office switch. A single Presubscription List will be provided to intraLATA toll providers as follows:

- (a) The Telephone Company will provide a list from its Customer data base. The list may be provided on magnetic tape, electronic transmission or paper printout, at the option of the IC or LEC, at rates provided in 6.8.1(A). Foreign listings, PBX stations, CU centrex stations, public coin station and numbers not in service will not be provided.
- (1) The Initial List will be provided to the IC or LEC no later than 30 days after receipt of the order and payment by the IC or LEC of charges in 6.8.1(A). The nonrecurring charge for the Initial List applies per order. A single order may contain all end offices having the same intraLATA equal access conversion date. The telephone number will not be provided if an end user or agent has a nonpublished number.
- (2) The Account Activity List, which includes a listing of all changes to the Customer data base, since the Initial List was produced, will be provided on a cyclic basis. The Account Activity List will only include information for those end users and agents that are presubscribed to the IC or LEC (including end users and agents with nonpublished numbers) for the sole purpose of updating the IC's or LEC's Customer account information. There is no charge for this list.
- (b) The IC or LEC agrees to use the Initial List for the sole purpose of contacting potential Customers/agents, or existing Customers/agents, regarding intraLATA telecommunications services available through equal access to be obtained from the Telephone Company. The IC or LEC agrees not to sell, or reproduce in any manner, in whole or in part, the lists or permit such to be done.
- (c) The IC or LEC shall indemnify, protect and save harmless the Telephone Company from and against any and all loss, liability, damages and expense arising out of any demand, claim, suit or judgment for damages which may arise out of the Telephone Company's supplying of listing information, services or records.
- (d) The Telephone Company and the IC or LEC agree that the mutual objective of the parties is to conduct their respective businesses to avoid confusion by the end users and agents as to the separate and independent identity of the respective companies and their services. Neither the Telephone Company nor the IC or LEC shall make any representation to end users, the public, prospective advertisers, expressed or implied, written or oral, which would imply that the IC or LEC is the same as, a part of, or associated with the Telephone Company.
- (e) This service may be terminated by either the Telephone Company or the IC or LEC upon thirty (30) days' written notice. The Telephone Company reserves the right to terminate this service immediately upon written notice if the IC or LEC misuses the list information. Performance by the Telephone Company shall be excused in the event of strike, riot, act of God or any other cause beyond the reasonable control of the Telephone Company.

FILED

Issued: May 10, 2000

Effective: August 1, 2000

CANCELLED
October 19, 2009
Missouri Public
Service Commission
TN-2010-0092; YI-2010-0175

Kenneth Matzdorff
Chief Operating Officer
Kansas City, Missouri

AUG 01 2000
00 - 182
MISSOURI
Public Service Commission

FACILITIES FOR INTRASTATE ACCESS

RECEIVED6. MISCELLANEOUS SERVICES (Cont'd)

MAY 10 2000

6.8 End User/Agent Lists (Cont'd)**MISSOURI
Public Service Commission**(B) Allocation Lists

- (1) The Telephone Company will provide to the IC or LEC, at no charge, a list of end users and agents that have been allocated to the IC or LEC as described in 6.5(B). This list will be provided after the Balloting and Allocation Process occurs.
- (2) A list of all end users and agents who have been allocated, in accordance with 6.5(B), will be available to an IC or LEC upon request. Charges in 6.8.1(A) will apply. The nonrecurring charge for the Allocation List applies each time the IC or LEC orders the service. A single order may contain all end offices having the same equal access conversion date.

FILEDAUG 01 2000
00 - 182**MISSOURI
Public Service Commission**

Issued: May 10, 2000

Effective: August 1, 2000

CANCELLED
October 19, 2009
Missouri Public
Service Commission
TN-2010-0092; YI-2010-0175Kenneth Matzdorff
Chief Operating Officer
Kansas City, Missouri

RECEIVED

FACILITIES FOR INTRASTATE ACCESS

MAY 10 2000

6. MISCELLANEOUS SERVICES (Cont'd)

6.8 End User/Agent Lists (Cont'd)

6.8.1 Rates and Charges

**MISSOURI
Public Service Commission**

(A) Initial and Allocation Lists

<u>Nonrecurring Charge Per ASR</u>	<u>Initial List Per Customer* Account</u>	<u>Allocation List Per Listing*</u>
\$50.00	\$ 0.03	\$ 0.03

FILED

AUG 01 2000

00 - 182

**MISSOURI
Public Service Commission**

* For the purpose of the Initial Lists a customer is defined in Section 2.6. For the purpose of the Allocation list, a listing is defined as an end user record eligible for a Predesignated Interexchange Carrier Selection.

Issued: May 10, 2000

Effective: August 1, 2000

CANCELLED
October 19, 2009
Missouri Public
Service Commission
TN-2010-0092; YI-2010-0175

Kenneth Matzdorff
Chief Operating Officer
Kansas City, Missouri

RECEIVED

FACILITIES FOR INTRASTATE ACCESS

MAY 10 2000

6. MISCELLANEOUS SERVICES (Cont'd)**MISSOURI
Public Service Commission**6.9 Billing Name and Address Services

The Telephone Company will, upon request, provide Billing Name and Address Services (BNAS) to a Telecommunications Service Provider (customer), or its authorized billing and collection agent. Telecommunications Service Providers include interexchange carriers, operator service providers, enhanced service providers, and any other provider of intrastate telecommunications services. There are three BNAS offerings available pursuant to this tariff, Per Call/Periodic BNA, Data Gathering Service (DGS), and End User Validation List.

(A) Per Call/Periodic BNA and Data Gathering Service

Per Call/Periodic BNA is the billing name and address information and Data Gathering is the billing telephone number, name, address and associated working telephone number information for customer provided ten digit end user telephone numbers required by the Telecommunications Service Provider customer to bill for calls placed within a specific time period. Per Call/Periodic BNA and DGS are offered subject to the conditions set forth in the following:

- (1) A standard format for the receipt and provision of telephone number and billing name and address information will be established by the Telephone Company. Charges for each Per Call/Periodic BNA searched for and found or searched for and not found will be billed at rates in 6.9.1(A). Charges for each record accessed for DGS are set forth under 6.9.1(B). Per Call/Periodic BNA and DGS will be provided via magnetic tape, electronic transmission, or paper format, at the option of the customer, at rates in 6.9.1. The processing fee will be applied on a per state basis, once per calendar year for BNAS processing done within that calendar year.
- (2) The customer must order Per Call/Periodic BNA or DGS and provide test data tape at least 30 days prior to delivery of the first customer order.
- (3) The frequency for receipt of the customer provided orders for Per Call/Periodic BNA or DGS will be no more than twice monthly and at intervals mutually agreed upon between the Telephone Company and the customer. The customer provided end user telephone numbers will be programmed by the Telephone Company with the proper end user's billing name and address contained in the Telephone Company's file at that time.
- (4) Per Call/Periodic BNA and DGS information for nonlisted/nonpublished end user telephone numbers will be provided unless the nonlisted/nonpublished end user provides notice of nonconsent to the Telephone Company of nonconsent to the release of the BNA/DGS data. Within 30 days of receipt of such notice, the Telephone Company will discontinue disclosure of the nonlisted/nonpublished BNA/DGS data.
- (5) For other than electronic transmission, the output records will be sent to the customer via first class U. S. Mail. The output records will normally be made available for mailing ten workdays after receipt of the customer order or at an interval mutually agreed upon. Availability may be delayed in case of input errors in the customer provided order.
- (6) The customer may request data be transmitted. Data transmission charges will be determined on an ICB. Data transmission hardware and software specifications will be mutually agreed upon by the Telephone Company and the customer.
- (7) Per Call/Periodic BNA and DGS detail will not be retained by the Telephone Company longer than 45 days. If the customer requests that the output be made available on a second occasion, such request must occur within 30 days from the date the first was made.
- (8) Any customer, provided Per Call/Periodic BNA or DGS pursuant to this tariff, agrees to abide by all applicable rules, decisions, orders, statutes and laws concerning the disclosure of published and nonpublished telephone numbers, and further agrees to use the information contained therein only for the purpose of billing for services provided to their end users.
- (9) In no case shall any customer or authorized billing and collection agent of a customer disclose the billing name and address information of any subscriber to any third party, except that a customer may disclose BNA/DGS information to its authorized billing and collection agent or to governmental law enforcement agencies.

FILED

Issued: May 10, 2000

Effective: August 1, 2000

AUG 01 2000 182

CANCELLED
October 19, 2009
Missouri Public
Service Commission
TN-2010-0092; YI-2010-0175

Kenneth Matzdorff
Chief Operating Officer
Kansas City, Missouri

**MISSOURI
Public Service Commission**

FACILITIES FOR INTRASTATE ACCESS

RECEIVED6. MISCELLANEOUS SERVICES (Cont'd)

MAY 10 2000

6.9 Billing Name and Address Services (Cont'd)MISSOURI
Public Service Commission

(A) (Cont'd)

(10) Conditions regarding refusal or discontinuance of this service are set forth in 2.1.8.

(B) End User Validation List

End User Validation Lists provide for the disclosure of all or a portion of end user/agent data available from the Telephone Company's records, to a Telecommunications Service Provider (customer), for purposes other than billing, and in compliance with the conditions set forth in Part 64.1201(c)(1) of the FCC's Rules and Regulations. In addition, End User Validation List Service is offered subject to the conditions set forth in 6.9(A)(9) above, and the following:

- (1) Standard End User Validation Lists will be provided in three (3) files, business, coin (semi-public and public paystations) and residence. Nonlisted/nonpublished information will be excluded, with the exception of nonlisted public paystations. The lists may be ordered on a national, multi-state or state level basis, at the option of the customer, for any of the Telephone Company's jurisdictions subject to this tariff, unless prohibited by federal regulation or federal statute. Rates for the standard End User Validation List are set forth under 6.9.1(C).
- (2) Per calendar year, the customer may request up to two (2) lists per state for business, coin, and residence listings.
- (3) A standard format will be established by the Telephone Company. Requests for special list sorts will be limited to an end user list separating those that are presubscribed to the requesting customer, and/or those that are not. The rate, per record, applicable to special sorts is set forth under 6.9.1(C).
- (4) Each request shall be treated as a new request. Requests for updates from previous lists will not be provided.
- (5) The customer shall have fifteen (15) business days from the date of delivery of a list to request any investigation of issues arising from the provision of the list.
- (6) End User Validation Lists will normally be provided to the customer within thirty calendar days after receipt of a request and within ten (10) business days of extraction, or at an interval mutually agreed upon. The administrative fee set forth under 6.9.1(C) applies per request, whether ordered on a per state, multi-state, or national level.
- (7) Conditions regarding refusal or discontinuance of this service are set forth in 2.1.8.

FILED

AUG 01 2000

00-182
MISSOURI
Public Service Commission

Issued: May 10, 2000

Effective: August 1, 2000

FACILITIES FOR INTRASTATE ACCESS

RECEIVED

6. MISCELLANEOUS SERVICES (Cont'd)

MAY 10 2000

6.9 Billing Name and Address Services (BNAS) (Cont'd)

6.9.1 Rates and Charges

MISSOURI Public Service Commission Processing Fee* Paper Report, Electronic Transmission, or Magnetic Tape/Each State

(A) Per Call/Periodic BNA

Billing Name and Address Found/Each	Billing Name and Address Not Found/Each	
\$.25	\$.25	\$50.00

(B) Data Gathering Service

Per Record Accessed	Processing Fee ** Paper Report, Electronic Transmission, or Magnetic Tape/Each State
\$.18	\$75.00

(C) End User Validation List

Standard Sort, Per Record Provided	Administrative Fee Paper Report, Electronic Transmission or Magnetic Tape/ Per Request	Special Sort, Per Record Provided
\$.034	\$78.00	\$.054

FILED

AUG 01 2000

MISSOURI Public Service Commission

* Applies once per calendar year for BNA processing done within that calendar year. ** Applies once per calendar year for DGS processing done within that calendar year.

FACILITIES FOR INTRASTATE ACCESS

RECEIVED

SECTION 7 TABLE OF CONTENTS

MAY 10 2000

7. SPECIALIZED FIA OR ARRANGEMENTS

Sheet

7.1 General

MISSOURI
Public Service Commission

7.2 Rates and Charges

255

FILED

AUG 01 2000
00-182

MISSOURI
Public Service Commission

Issued: May 10, 2000

Effective: August 1, 2000

CANCELLED
October 19, 2009
Missouri Public
Service Commission
TN-2010-0092; YI-2010-0175

Kenneth Matzdorff
Chief Operating Officer
Kansas City, Missouri

FACILITIES FOR INTRASTATE ACCESS

RECEIVED

MAY 10 2000

7. SPECIALIZED FIA OR ARRANGEMENTS

7.1 General

Specialized FIA or Arrangements may be provided by the Telephone Company at the request of a customer, on an Individual Case Basis (ICB) if such FIA or arrangements meet the following criteria:

- The requested FIA or arrangements are not offered under other sections of this tariff.
- The facilities utilized to provide the requested FIA or arrangements are of a type normally used by the Telephone Company in furnishing its other services.
- The requested FIA or arrangements are provided within a Market Area.
- The requested FIA or arrangements are compatible with other Telephone Company services, facilities, and its engineering and maintenance practices.

This offering is subject to the availability of the necessary Telephone Company personnel and capital resources.

7.2 Rates and Charges

Rates and charges and additional regulations, if applicable, for Specialized FIA or Arrangements are filed following:

7.2.1	<u>Customer</u>	<u>Description and Location</u>	<u>Charges</u>
	(Reserved for Future Use)		

FILED
 AUG 01 2000
 00 - 182
 MISSOURI
 Public Service Commission

Issued: May 10, 2000

Effective: August 1, 2000

CANCELLED
 October 19, 2009
 Missouri Public
 Service Commission
 TN-2010-0092; YI-2010-0175

Kenneth Matzdorff
 Chief Operating Officer
 Kansas City, Missouri

FACILITIES FOR INTRASTATE ACCESS

RECEIVED

SECTION 8 TABLE OF CONTENTS

8. ANCILLARY SERVICES

MAY 10 2000

Sheet

8.1	<u>General</u>		257
8.1.1	Service Offerings		257
8.1.2	Regulations		257
	(A) Undertaking of the Telephone Company		257
	(1) Provision of Ancillary Services		258
	(2) Discontinuance and Refusal of Ancillary Services		258
	(B) Obligations of the Customer		259
	(1) References to the Telephone Company		259
	(2) Request for Service		259
	(a) Minimum Order Periods		259
	(b) Order Requirements		260
	(C) Payment Arrangements		261
	(1) Minimum Charges		261
	(2) Cancellation of Order for Ancillary Services		262
	(3) Acceptance of Gift Certificates		262
	(4) Minimum Period Disconnect Charges		263
	(5) Payment of Charges		264
	(6) End User Deposits		264
8.1.3	Description of Ancillary Services		264
	(A) Call Recording Service		264
	(B) Message Processing Service		265
	(C) Assembly and Editing Service		267
	(D) Call Record Provision Service		268
	(E) Message Bill Processing Service		269
	(F) Bill Rendering Service		270
	(G) Message Investigation Service		270.1
	(H) Specialized Billing Service		270.1
	(I) (Reserved for Future Use)		270.2
	(J) Program Development Service		270.3
	(K) Inquiry Service		270.3
8.1.4	Rate Regulations		270.5
8.1.5	Rates and Charges		270.8

FILED

AUG 01 2000

00 - 182

MISSOURI
Public Service Commission

FACILITIES FOR INTRASTATE ACCESS

RECEIVED8. ANCILLARY SERVICES

MAY 10 2000

8.1 GENERAL8.1.1 Service OfferingsMISSOURI
Public Service Commission

Ancillary Services are available in the following categories:

- Call Recording Service
- Message Processing Service
- Assembly and Editing Service
- Call Record Provision Service
- Message Bill Processing Service
- Bill Rendering Service
- Message Investigation Service
- Specialized Billing Service
- Program Development
- Inquiry Service

Regulations, rates and charges as follows apply to Ancillary Services and shall not serve as a substitute for customer tariff offerings of services to end users. The provision of such Ancillary Services by the Telephone Company, as set forth following, does not constitute a joint undertaking with the customer for the furnishing of any service.

The Telephone Company's undertaking to provide Ancillary Services is made only in conjunction with intrastate services offered within its operating territory.

The regulations, rates and charges contained herein are in addition to the applicable regulations, rates and charges specified in other sections of this tariff and in other tariffs of the Telephone Company which are referenced herein.

8.1.2 Regulations(A) Undertaking of the Telephone Company(1) Provision of Ancillary Services

- (a) The Telephone Company, to the extent Ancillary Service are, or can be made available with reasonable effort, will provide to the customer Ancillary Services as described in 8.1.3, at rates and charges as specified in 8.1.5.
- (b) When the customer subscribes to Call Recording Service, as set forth in 8.1.3(A), and customer message detail is not available because the Telephone Company lost or damaged tapes or incurred recording system outages, the Telephone Company will estimate the volume of lost customer messages and associated revenue based on previously known values determined from historical data. In such events the extent of the Telephone Company's liability for damages shall be limited to the granting of a corresponding credit adjustment on the customer's bill representing amounts due to the customer for the unbilled revenue.

FILED

AUG 01 2000

00 - 182

MISSOURI
Public Service Commission

Issued: May 10, 2000

Effective: August 1, 2000

FACILITIES FOR INTRASTATE ACCESS

RECEIVED8. ANCILLARY SERVICES (Cont'd)

MAY 10 2000

8.1 GENERAL (Cont'd)**MISSOURI
Public Service Commission**8.1.2 Regulations (Cont'd)(A) Undertaking of the Telephone Company (Cont'd)(1) Provision of Ancillary Services (Cont'd)

(b) (Cont'd)

When the Telephone Company is notified that, due to error or omission, incomplete data has been provided to a customer, the Telephone Company will make every reasonable effort to locate and/or recover the data and provide new magnetic tapes to the customer at no additional charge. Such request to recover the data must be made within 30 days from the date the details were initially made available to the customer. If the data cannot be recovered, the extent of the Telephone Company's liability for damages shall be limited as set forth in the preceding paragraph.

(c) The Telephone Company shall be responsible for contacts and arrangements with the end user concerning the billing, collecting, crediting and adjusting of the customer's service charges, when the Telephone Company provides Inquiry Service as set forth in 8.1.3(K).

(d) Message Bill Processing, Bill Rendering, Specialized Billing Service and Inquiry Services will only be offered by the Telephone Company with the purchase of receivables. The Telephone Company will purchase the customer's receivables at a discount from face value. The exact contents of the discount factor and specific settlement procedures will be contained in individual contractual arrangements signed by each customer.

(2) Discontinuance and Refusal of Ancillary Services

(a) If the customer fails to comply with the provisions herein, including any payments to be made by it on the dates or at the times herein specified, and fails within thirty (30) days after written notice via certified mail from the Telephone Company to an officer of the customer requesting payment for such noncompliance, the Telephone Company may discontinue the provision of the Ancillary Services. In case of such discontinuance, all applicable charges shall immediately become due.

(b) If the customer repeatedly fails to comply with the provisions of this section in connection with the provision of Ancillary Services and fails to correct such course of action after notice as set forth in (a) preceding, the Telephone Company may refuse applications for additional Ancillary Services.

FILEDAUG 01 2000
00-182**MISSOURI
Public Service Commission**

Issued: May 10, 2000

Effective: August 1, 2000

CANCELLED
October 19, 2009
Missouri Public
Service Commission
TN-2010-0092; YI-2010-0175

Kenneth Matzdorff
Chief Operating Officer
Kansas City, Missouri

FACILITIES FOR INTRASTATE ACCESS

RECEIVED

MAY 10 2000

**MISSOURI
Public Service Commission**8. ANCILLARY SERVICES (Cont'd)8.1 GENERAL (Cont'd)8.1.2 Regulations (Cont'd)(B) Obligations of the Customer(1) References to the Telephone Company

The customer may advise end users that Ancillary Services are provided by the Telephone Company in connection with the service the customer furnishes to end users.

(2) Request for Service(a) Minimum Order Periods

The customer shall order Ancillary Service(s) with the following minimum requirements:

The minimum period for which Call Recording Service is provided and for which charges apply is one month (30 days). A customer may cancel Call Recording Service on any date prior to the start of the next month's service. If written notice is not received from the customer, or from the telephone company that ordered the Call Recording Service prior to the start of the following month's service, the Telephone Company shall assume that the service is to be extended for another month (30 days).

The initial minimum period for Message Processing, Message Bill Processing, Bill Rendering, Specialized Billing and Inquiry Services is three years. Six months prior to the end of the initial order period or subsequent extension, the customer shall notify the Telephone Company in writing, if the service is to be discontinued. If no notice is received from the customer, the Telephone Company shall assume that the service is extended for another year.

FILED

AUG 01 2000

**MISSOURI 8 2
Public Service Commission**

Issued: May 10, 2000

Effective: August 1, 2000

FACILITIES FOR INTRASTATE ACCESS

8. ANCILLARY SERVICES (Cont'd)8.1 GENERAL (Cont'd)8.1.2 Regulations (Cont'd)(B) Obligations of the Customer (Cont'd)(2) Request for Service (Cont'd)(b) Order Requirements

When Call Recording Service is ordered, the customer shall furnish the Telephone Company an estimate of the number of messages (message capacity) to be recorded. When Call Recording Service is provided from an end office switch, the estimate of the number of messages to be recorded shall be provided by end office. When Call Recording Service is provided from an access tandem, the estimate of the number of messages to be recorded shall be provided by access tandem. The message capacity shall be provided by year.

When Message Processing Service is ordered, the customer shall furnish the Telephone Company an estimate of the number of messages (message capacity) to be processed. The number of messages shall be provided by year.

When Message Bill Processing, Message Investigation, Specialized Billing and Inquiry Services are ordered for MTS/WATS services, the customer shall furnish the Telephone Company an estimate of the number of messages (message capacity) to be billed. The message capacity shall be provided by year. Separate estimates shall be furnished by the customer for MTS messages, bulk-billed messages (WATS/800 services) and invoice billing messages.

When Bill Rendering Service is ordered, the customer shall furnish the Telephone Company an estimate of the number of bills for which Bill Rendering Service will be provided. The bill capacity shall be provided by year. Separate estimates shall be furnished by the customer for MTS bills, bulk-billed (WATS/800) bills and invoice billing bills.

RECEIVED

MAY 10 2000

MISSOURI
Public Service Commission**FILED**AUG 01 2000
00 - 182MISSOURI
Public Service Commission

Issued: May 10, 2000

Effective: August 1, 2000

FACILITIES FOR INTRASTATE ACCESS

8. ANCILLARY SERVICES (Cont'd)

8.1 GENERAL (Cont'd)

8.1.2 Regulations (Cont'd)

(C) Payment Arrangements

(1) Minimum Charges

- (a) Call Recording, Message Processing, Message Bill Processing, Specialized Billing, Bulk-Billed and Inquiry Services are subject to minimum charges.
- (b) Any minimum billing associated with the above services will be filed on an individual case basis.

RECEIVED

MAY 10 2000

**MISSOURI
Public Service Commission**

FILED

AUG 01 2000
8 01 - 182

**MISSOURI
Public Service Commission**

Issued: May 10, 2000

Effective: August 1, 2000

CANCELLED
October 19, 2009
Missouri Public
Service Commission
TN-2010-0092; YI-2010-0175

Kenneth Matzdorff
Chief Operating Officer
Kansas City, Missouri

FACILITIES FOR INTRASTATE ACCESS

RECEIVED

8. ANCILLARY SERVICES (Cont'd)

MAY 10 2000

8.1 GENERAL (Cont'd)

**MISSOURI
Public Service Commission**

8.1.2 Regulations (Cont'd)

(C) Payment Arrangements (Cont'd)

(2) Cancellation of Order for Ancillary Services

- (a) When an order for Ancillary Services is canceled prior to the start of installation of such Ancillary Services, no charges will apply. Installation of Ancillary Services is considered to have started when the Telephone Company incurs any cost in connection therewith or in preparation thereof which would not otherwise have been incurred.
- (b) Where program development of Ancillary Services has been started prior to the cancellation, and to the extent the Telephone Company has another use for the specially developed Ancillary Services, no charge applies. When the Telephone Company has no other use for the specially developed Ancillary Services, a charge equal to the costs incurred prior to the date of cancellation applies. Such charge is determined as detailed in paragraph (c).
- (c) The charge, as specified in paragraph (b), includes the cost, less the net salvage value of equipment and material either ordered, provided or installed, plus the nonrecoverable cost of system development and installation. Charges will be determined on an individual case basis as required and will be specified in 8.1.5(B).

(3) Acceptance of Gift Certificates

The Telephone Company will accept customer gift certificates for payment from end users, if the customer agrees in writing to redeem all such gift certificates.

FILED

AUG 01 2000

00-182

**MISSOURI
Public Service Commission**

FACILITIES FOR INTRASTATE ACCESS

RECEIVED

MAY 10 2000

MISSOURI
Public Service Commission

8. ANCILLARY SERVICES (Cont'd)

8.1 GENERAL (Cont'd)

8.1.2 Regulations (Cont'd)

(C) Payment Arrangements (Cont'd)

(4) Minimum Period Disconnect Charges

Minimum period disconnect charges will apply, if service is discontinued prior to the expiration of the minimum period. For Call Recording Service, the Telephone Company will use the most recent 30 day period for which data is available to determine the total minimum monthly charge. The customer will only be billed for the adjusted amount due, if payment has been received for any portion of the discontinued service.

If, for Message Processing, Message Bill Processing, Bill Rendering, Specialized Billing and Inquiry Services, service is discontinued prior to the end of the period ordered, the customer will pay the minimum charges for the remaining months of the minimum order period specified in 8.1.2(B)(2)(a).

The monthly charge for Message Processing, Message Bill Processing, Bill Rendering, Specialized Billing and Inquiry Services, will be one-twelfth of the appropriate yearly message capacity (i.e., MTS service billed or bulk-billed capacity estimate) furnished by the customer as set forth above, times the appropriate Message Processing, Message Bill Processing, Bill Rendering, Specialized Billing and Inquiry Services rate.

FILED

AUG 01 2000

00-182
MISSOURI

Public Service Commission

Issued: May 10, 2000

Effective: August 1, 2000

CANCELLED
October 19, 2009
Missouri Public
Service Commission
TN-2010-0092; YI-2010-0175

Kenneth Matzdorff
Chief Operating Officer
Kansas City, Missouri

FACILITIES FOR INTRASTATE ACCESS

RECEIVED

8. ANCILLARY SERVICES (Cont'd)

MAY 10 2000

8.1 GENERAL (Cont'd)

MISSOURI
Public Service Commission

8.1.2 Regulations (Cont'd)

(C) Payment Arrangements (Cont'd)

(5) Payment of Charges

When the Telephone Company purchases Call Recording from another telephone company and/or Message Processing Services from another telephone company or entity for a customer, the rates and charges for such services identified herein are applicable.

(6) End User Deposits

When Bill Rendering and Specialized Billing Services are ordered, the Telephone Company will determine and collect a deposit from the end user in accordance with the Telephone Company deposit regulations. The Telephone Company will provide the customer with a copy of its deposit regulations upon request.

8.1.3 Description of Ancillary Services

Ancillary Services shall be furnished to subscribers to the Telephone Company's access services, and in addition other telecommunications service providers, including providers of telephone answering services or voice messaging services.

All subscribers of Ancillary Services are subject to the terms and conditions contained within this tariff. Should the customer choose to perform his/her own ancillary functions and require sufficient information to do so, listed customer information may be purchased consistent with state regulations governing any rights to privacy. Charges for such lists will be calculated on an individual basis.

Ancillary Services are as follows:

(A) Call Recording Service

The Telephone Company will provide Call Recording in Telephone Company suitably equipped end offices or tandems. Call recording is available with FGC, FGD or similar Feature Group offerings when used in the provision of MTS/WATS services. Call Recording is the entering on magnetic tape or other acceptable media the details of customer messages originated through Switched Access Service or Switched Access-like service for which answer and disconnect supervision has been received. The Telephone Company will provide the customer, upon request, the recorded message detail, as agreed to by both parties, for each completed intrastate message generated by end users gaining access to the customer from the Access Area.

FILED

AUG 01 2000

00-182
MISSOURI
Public Service Commission

FACILITIES FOR INTRASTATE ACCESS

RECEIVED8. ANCILLARY SERVICES (Cont'd)

MAY 10 2000

8.1 GENERAL (Cont'd)8.1.3 Description of Ancillary Services (Cont'd)**MISSOURI
Public Service Commission**(A) Call Recording Service (Cont'd)

The equipment at the customer designated location shall provide such signals as may be required for the proper operation of the Telephone Company's automatic call recording equipment used to perform this function.

The Telephone Company may purchase Call Recording Service from another telephone company. Another telephone company or entity may purchase Call Recording Service from the Telephone Company.

A standard format for the provision of the recorded message detail will be established by the Telephone Company. The Telephone Company will provide to the customer the precise details of the format. If, in the course of Telephone Company business, it is necessary to change the format, the Telephone Company will provide notification to the customer six months in advance of the change.

(B) Message Processing Service

Message Processing Service consists of the transformation of recorded customer message details into rated messages. Message Processing Service will be provided for each intrastate message generated by end users gaining access to the customer from the Access Area of the Telephone Company. Message Processing Service includes the following:

(1) Assembly of Message Detail

This function consists of arranging the customer's recorded message details into a format required for subsequent processing.

FILED

AUG 01 2000

00-182
**MISSOURI 2
Public Service Commission**

Issued: May 10, 2000

Effective: August 1, 2000

CANCELLED
October 19, 2009
Missouri Public
Service Commission
TN-2010-0092; YI-2010-0175

Kenneth Matzdorff
Chief Operating Officer
Kansas City, Missouri

FACILITIES FOR INTRASTATE ACCESS

RECEIVED

8. ANCILLARY SERVICES (Cont'd)

MAY 10 2000

8.1 GENERAL (Cont'd)

MISSOURI
Public Service Commission

8.1.3 Description of Ancillary Services (Cont'd)

(B) Message Processing Service (Cont'd)

(2) Editing of Message Detail

This function consists of examining individual message detail and identifying the messages with errors or the messages which require further examination.

(3) Rating of Messages

This function consists of calculating the charges for messages based on the customer's schedule of charges and the message detail.

The Telephone Company will provide Message Processing Service only for customer messages originated within the Access Area.

For the purpose of performing Message Processing Service, the Telephone Company may purchase Message Processing Service from another Telephone Company or entity as set forth in 8.1.2(C)(5). Another telephone company or entity may purchase Message Processing Service from the Telephone Company.

Where the customer provides its own message details, it must be in the standard format established by the Telephone Company. The Telephone Company will provide to the customer the precise details of the required format. If, in the course of Telephone Company business, it is necessary to change the format, the Telephone Company will provide notification to the customer six months in advance of the change.

Where the Telephone Company has rated customer messages which are to be billed to an end user by another telephone company or entity, the Telephone Company will enter the customer messages on a magnetic tape or data file and transmit the rated messages as set forth in 8.1.3(D).

FILED

AUG 01 2000
00-182

MISSOURI
Public Service Commission

Issued: May 10, 2000

Effective: August 1, 2000

FACILITIES FOR INTRASTATE ACCESS

RECEIVED

8. ANCILLARY SERVICES (Cont'd)

MAY 10 2000

8.1 GENERAL (Cont'd)

**MISSOURI
Public Service Commission**

8.1.3 Description of Ancillary Services (Cont'd)

(C) Assembly and Editing Service

Assembly is the aggregation of recorded message details to create individual messages for rating. Editing is the process of verifying that the assembled message data is in accordance with the Telephone Company standard format and prescribed Exchange Message Interface (EMI) specifications.

The editing function consists of examining individual message detail and identifying the messages with errors or the messages requiring further examination. The editing process includes the validation of data categories such as; but not limited to, the following:

- Called Telephone Number
- Calling Telephone Number
- Date

The assembled and edited recorded message detail will be provided to the customer as set forth in 8.1.3(D).

FILED

AUG 01 2000
00 - 182
MISSOURI

Public Service Commission

Issued: May 10, 2000

Effective: August 1, 2000

FACILITIES FOR INTRASTATE ACCESS

RECEIVED

MAY 10 2000

**MISSOURI
Public Service Commission**

8. ANCILLARY SERVICES (Cont'd)

8.1 GENERAL (Cont'd)

8.1.3 Description of Ancillary Services (Cont'd)

(D) Call Record Provision Service

Call Record Provision Service is the transmission and receipt of rated and unrated message data. It also includes the transmission of end user data as a result of customer generated activity (i.e., transmitting end user data during conversion activities, etc.).

The billing information and/or end user data may be transmitted or received on magnetic tape or other acceptable media via either of two principal methods:

- Hand carried recording media (i.e., magnetic tape).
- Direct interface (data link) to the Telephone Company billing center.

The Telephone Company will determine the number of magnetic tapes required to transmit message/record data to the customer, another telephone company or billing entity.

FILED

AUG 01 2000
0 8 1 8 2

**MISSOURI
Public Service Commission**

Issued: May 10, 2000

Effective: August 1, 2000

CANCELLED
October 19, 2009
Missouri Public
Service Commission
TN-2010-0092; YI-2010-0175

Kenneth Matzdorff
Chief Operating Officer
Kansas City, Missouri

FACILITIES FOR INTRASTATE ACCESS

RECEIVED

8. ANCILLARY SERVICES (Cont'd)

MAY 10 2000

8.1 GENERAL (Cont'd)

MISSOURI
Public Service Commission

8.1.3 Description of Ancillary Services (Cont'd)

(E) Message Bill Processing Service

Message Bill Processing Service is the accumulation, guiding and preparation of messages (including the application of taxes) for end user bill rendering for MTS/WATS services.

Message-Billed Message Bill Processing Service is the accumulation, guiding, posting and formatting of rated message detail for bill rendering. The Telephone Company will process Calling Plans (i.e., Directory Assistance, Optional Calling Plans, Dial-It calls, etc.) that require the application of a discount to aggregate MTS usage as a part of its Message-Billed Message Bill Processing Service.

Bulk-Billed Message Bill Processing Service is the accumulation, guiding and posting of rated message detail where the individual message detail is not provided on the bill rendered to the end user.

The rating may have been done by the Telephone Company, another entity or the customer. Where a customer subscribes to Message Processing Service, as set forth in 8.1.3(B), the rated customer messages will be used as the input. If the customer provides the rated messages, the end user account to be billed shall be identified and the records shall be provided in the standard format established by the Telephone Company and delivered, as set forth in 8.1.3(D) or 8.1.4(M), to the location specified by the Telephone Company.

If the customer provided rated messages must be converted by the Telephone Company to the standard format, and the Telephone Company agrees to make the conversion, program development charges as set forth in 8.1.5 apply for the hours required to design, develop, test and maintain the necessary programs. If, in the course of Telephone Company business, it is necessary to change the format, the Telephone Company will provide notification to the customer six months in advance of the change.

The Telephone Company will only provide Message Bill Processing Service when Bill Rendering Service and Record Keeping are ordered.

FILED

AUG 01 2000
00-182

MISSOURI
Public Service Commission

FACILITIES FOR INTRASTATE ACCESS

RECEIVED

8. ANCILLARY SERVICES (Cont'd)

MAY 10 2000

8.1 GENERAL (Cont'd)

**MISSOURI
Public Service Commission**

8.1.3 Description of Ancillary Services (Cont'd)

(F) Bill Rendering Service

Bill Rendering Service is the printing and mailing of statements showing amounts due from end users for services provided by the customer. Bill Rendering Service includes payment and remittance processing, treatment, denial of service and collection of deposits (where appropriate) and other monies due from the end user. Bill Rendering Service is provided on a per bill basis.

When the Telephone Company provides Bill Rendering Service, the customer's statement of the amount due may, at Telephone Company option, be included as part of the regular monthly bill for local exchange service mailed to the end user.

The Telephone Company may, in accordance with its deposit regulations, determine and collect a deposit from the end user for the customer's services as set forth in 8.1.2(C)(6). When necessary, the Telephone Company, in accordance with its treatment procedures, shall deny the customer's services and/or local exchange services to an end user. Where local exchange service access is denied, access to the customer services will also be denied.

Bill Rendering Service will only be provided in conjunction with the purchase of a customer's receivables. The Telephone Company will not be responsible for any customer's balance due from end users prior to the initial order period.

The Telephone Company will only provide Bill Rendering Service when Message Bill Processing Service with Record Keeping is ordered.

The Bill Rendering Service rate band will be determined by the Telephone Company for each customer based on the total number of bills per year.

FILED

AUG 01 2000

00-182
MISSOURI

Public Service Commission

Issued: May 10, 2000

Effective: August 1, 2000

CANCELLED
October 19, 2009
Missouri Public
Service Commission
TN-2010-0092; YI-2010-0175

Kenneth Matzdorff
Chief Operating Officer
Kansas City, Missouri

FACILITIES FOR INTRASTATE ACCESS

RECEIVED

8. ANCILLARY SERVICES (Cont'd)

MAY 10 2000

8.1 GENERAL (Cont'd)

8.1.3 Description of Ancillary Services (Cont'd)

MISSOURI
Public Service Commission

(G) Message Investigation Service

The Telephone Company will provide Message Investigation Service when requested by the customer. Message Investigation Service is that activity undertaken by the Telephone Company to secure, or attempt to secure proper billing information in an effort to sustain or recharge the customer's message. The Telephone Company will investigate, at the request of the customer, unbillable messages to correct message detail information to allow for the proper billing application.

The customer's request for Message Investigation Service shall identify the customer message, the date the customer message was billed and the amount of the customer message. Message Investigation Service is provided on a per message investigated basis.

Message Investigation Service will be provided for each intrastate message generated by end users gaining access to the customer MTS/WATS services from the Access Area of the Telephone Company.

(H) Specialized Billing Service

Specialized Billing Service includes the preparation of bills, mailing of the bills to the end users and the collection of deposits and monies due from the end users. Specialized Billing Service also includes master file maintenance.

Specialized Billing Service is provided on a per message billed basis (message-billed). The Telephone Company will process Calling Plans (i.e., Directory Assistance, Optional Calling Plans, Dial-It calls, etc.) that require the application of a discount to aggregate MTS usage as a part of its message-billed billing.

When Specialized Billing Service is ordered, the Telephone Company will accumulate, guide and post rated messages in preparation for billing (includes the application of taxes). The Telephone Company will also print and mail statements showing amounts due from end users for MTS services provided by the customer.

Collection Service provided to the customer will include receiving payments from the end users, treatment of receivables, treatment of accounts, master file maintenance and collection of deposits (where appropriate) as set forth in 8.1.2(C) (6). When necessary, the Telephone Company, in accordance with its treatment procedures, shall deny the customer's services and/or local exchange services to an end user. Where local exchange service access is denied, access to the customer services will also be denied.

FILED

AUG 01 2000

00 - 182

MISSOURI
Public Service Commission

FACILITIES FOR INTRASTATE ACCESS

RECEIVED

8. ANCILLARY SERVICES (Cont'd)

MAY 10 2000

8.1 GENERAL (Cont'd)

**MISSOURI
Public Service Commission**

8.1.3 Description of Ancillary Services (Cont'd)

(H) Specialized Billing Service (Cont'd)

The rating may have been done by the Telephone Company, another entity or the customer. Where the customer subscribes to Message Processing Service as set forth in 8.1.3(B), the rated customer messages will be used as the input. If the customer or another entity provides the rated messages, the end user account to be billed shall be identified and the records shall be provided in the standard format established by the Telephone Company and delivered as set forth in 8.1.3(D).

Specialized Billing Service will only be provided in conjunction with the purchase of a customer's receivables. The Telephone Company will not be responsible for any customer's balance due from end users prior to the initial order period.

(I) (Reserved for Future Use)

FILED

AUG 01 2000
00 - 182
**MISSOURI
Public Service Commission**

Issued: May 10, 2000

Effective: August 1, 2000

CANCELLED
October 19, 2009
Missouri Public
Service Commission
TN-2010-0092; YI-2010-0175

Kenneth Matzdorff
Chief Operating Officer
Kansas City, Missouri

FACILITIES FOR INTRASTATE ACCESS

RECEIVED

8. ANCILLARY SERVICES (Cont'd)

MAY 10 2000

8.1 GENERAL (Cont'd)

**MISSOURI
Public Service Commission**

8.1.3 Description of Ancillary Services (Cont'd)

(J) Program Development Service

Program Development Service consists of developing the customer's schedule of rates into a rating program and changing the bill format when requested by the customer. Program Development Service also includes converting message data, transmitted to the Telephone Company by the customer or another entity, into the Telephone Company standard format for processing.

A Program Development Charge, as set forth in 8.1.5, applies for the programming hours required to design, develop and test the program.

Changes in the rate levels of customer charges to be billed will normally be implemented within 30 days after receipt of an order from the customer requesting such change. When modification to the rating program is required, a Program Development Charge will also apply. Changes in rate structure will normally be completed within six months of a customer's order.

The complexity of the structural change will determine the exact length of time necessary to fulfill the request. Rate structure changes will be made only when the Telephone Company can accommodate such changes.

(K) Inquiry Service

Inquiry Service consists of answering end user questions about charges billed for the customer's services, applying credits and adjustments to end user accounts, and reviewing messages removed from end user bills.

When the Telephone Company provides Inquiry Service, the Telephone Company will be responsible for contacts and arrangements (either written or oral) with the end users concerning the billing, collecting, crediting, adjusting and message investigation of the customer's service charges in accordance with written instructions furnished by the customer and agreed to by the Telephone Company. Billed messages removed from an end user's bill will be appropriately adjusted to the customer's account receivable as agreed to by both parties.

FILED

AUG 01 2000
00-182

**MISSOURI
Public Service Commission**

Issued: May 10, 2000

Effective: August 1, 2000

CANCELLED
October 19, 2009
Missouri Public
Service Commission
TN-2010-0092; YI-2010-0175

Kenneth Matzdorff
Chief Operating Officer
Kansas City, Missouri

FACILITIES FOR INTRASTATE ACCESS

RECEIVED8. ANCILLARY SERVICES (Cont'd)

MAY 10 2000

8.1 GENERAL (Cont'd)**MISSOURI
Public Service Commission**8.1.3 Description of Ancillary Services (Cont'd)(K) Inquiry Service (Cont'd)

The Telephone Company will not become involved in disputes between a customer and the end users. Consequently, utilizing Telephone Company guidelines previously established for the collection process for its own accounts, the Telephone Company may remove a disputed customer's charge from an end user's bill and deduct that amount from the customer's accounts receivable. It will be the customer's responsibility to pursue the collection of the disputed amount.

The Telephone Company shall have the final authority to make adjustments or deny service for disputed charges on end users accounts.

Inquiry Service will only be provided in conjunction with the purchase of a customer's receivables. The Telephone Company will not be responsible for any customer's balances due from end users prior to the initial order period.

Inquiry Service will only be provided when Message Bill Processing or Specialized Billing Service is ordered. Inquiry Service will only be provided in the Telephone Company operating territory.

FILED

AUG 01 2000

00 - 182

**MISSOURI
Public Service Commission**

Issued: May 10, 2000

Effective: August 1, 2000

FACILITIES FOR INTRASTATE ACCESS

RECEIVED8. ANCILLARY SERVICES (Cont'd)

MAY 10 2000

8.1 GENERAL (Cont'd)8.1.4 Rate RegulationsMISSOURI
Public Service Commission

- (A) Call Recording Service for MTS/WATS services includes the functions listed in 8.1.3(A). The rate, as set forth in 8.1.5, applies per message recorded.
- (B) Message Processing Service for MTS/WATS services includes the functions listed in 8.1.3(B). The rate, as specified in 8.1.5, applies per message processed. In those locations where WATS services are metered, or the billing record is summarized by another telephone company, the Message Processing rate, as set forth in 8.1.5, will apply per billing record processed. For rating purposes, a billing record is defined as any record which is required to be processed to accomplish billing of a customer's WATS usage.
- (C) Assembly and Editing Service for MTS/WATS services consists of the functions listed in 8.1.3(C). The rate, as specified in 8.1.5, applies per message assembled and edited.
- (D) When message detail is transmitted to or received from the customer, another telephone company or billing entity, a Call Record Provision charge will apply. For this purpose, a record is a logical grouping of information as described in the program that processes the information and loads the magnetic tape or data file. The rate, as specified in 8.1.5, applies per record transmitted or received. The Telephone Company will determine the Call Record Provision charge based on its count of the records transmitted or received.
- (E) The Message Bill Processing Service charge applies whenever the Telephone Company performs the functions listed in 8.1.3(E).

The rate, as specified in 8.1.5 applies per message processed. The bulk-billed Message Bill Processing Service charge applies per WATS/800 message processed.

FILEDAUG 01 2000
00 - 182MISSOURI
Public Service Commission

Issued: May 10, 2000

Effective: August 1, 2000

FACILITIES FOR INTRASTATE ACCESS

RECEIVED

8. ANCILLARY SERVICES (Cont'd)

MAY 10 2000

8.1 GENERAL (Cont'd)

MISSOURI
Public Service Commission

8.1.4 Rate Regulations (Cont'd)

(F) Bill Rendering Service includes the functions listed in 8.1.3(F). The rate for Bill Rendering shall be the rate corresponding to the Bill Rendering Service rate for such volume of bills for a particular Telephone Company Billing service as set forth in 8.1.5 on a calendar year basis. The term calendar year shall mean the period from January 1 through December 31 (both dates inclusive) of a given year. The Bill Rendering Service rate band is determined by the Telephone Company for each customer based on the total number of bills per year.

The Telephone Company will use the customer provided bill capacity to determine the band and its associated rate the first year of the initial minimum period. During the first quarter of the next year, the customer and the Telephone Company will determine the actual volume of bills for which the Telephone Company performed Bill Rendering Service. Such actual volumes shall be compared to the Bill Rendering Service bands as set forth in 8.1.5 to determine which band such actual volume of bills fall. If the actual volume is greater than or less than the customer provided bill capacity, the actual volume will be multiplied by the appropriate band rate and compared to the billed volume to determine either a charge or credit. This charge or credit will be applied to the customer's subsequent bill.

For each year thereafter, the Telephone Company and the customer shall utilize the previous year's actual volume of bills and the customer provided bill capacity in an effort to determine the appropriate band for the next calendar year. In the first quarter of each year, the procedures described in the previous paragraph will be followed.

The rate, as specified in 8.1.5 applies per bill rendered. A factor, based on actual interstate and intrastate billed-messages, will be used by the Telephone Company to apportion the Bill Rendering charge by jurisdiction.

(G) (Reserved for Future Use)

(H) Specialized Billing Service consists of the functions listed in 8.1.3(H). The rate, as set forth in 8.1.5, applies per message.

(I) (Reserved for Future Use)

(J) A Record Keeping charge applies for each end user account maintained by the Telephone Company for the customer. An end user account is a record which has a name and address and a unique billing identification number assigned by the Telephone Company to which a bill is rendered. The Record Keeping charge, as specified in 8.1.5, applies per month for each account and/or line maintained. A factor, based on actual interstate and intrastate billed messages, will be used to apportion the Record Keeping charge by jurisdiction.

FILED

AUG 01 2000

00 - 182
MISSOURI

Public Service Commission

Issued: May 10, 2000

Effective: August 1, 2000

CANCELLED
October 19, 2009
Missouri Public
Service Commission
TN-2010-0092; YI-2010-0175

Kenneth Matzdorff
Chief Operating Officer
Kansas City, Missouri

FACILITIES FOR INTRASTATE ACCESS

RECEIVED

MAY 10 2000

8. ANCILLARY SERVICES (Cont'd)8.1 GENERAL (Cont'd)8.1.4 Rate Regulations (Cont'd)**MISSOURI
Public Service Commission**

(K) An Exchange Carrier Memorandum (EC Memo) charge will be assessed each time the customer requests a manual adjustment to an end user account. The ED Memo charge, as specified in 8.1.5, applies per account adjusted per memo. When necessary, a factor (based on actual interstate and intrastate adjusted messages) will be used to apportion the EC Memo charge by jurisdiction.

(L) (Reserved for Future Use)

(M) (Reserved for Future Use)

(N) Inquiry Service includes the functions listed in 8.1.3(K). Inquiry Service for IXC customers consists of a bifurcated rate structure, a per message billed and a per adjustment rate. The Inquiry Service per message billed rate applies for each customer message billed by the Telephone Company. The per message adjustment rate applies for each occurrence of an adjustment made to an end user bill (account). For LEC customers, Inquiry Service consists of a single, per message billed, rate structure.

A PIU factor will be used by the Telephone Company to apportion the message adjustment rate by jurisdiction.

FILED

AUG 01 2000 8 2

**MISSOURI
Public Service Commission**

Issued: May 10, 2000

Effective: August 1, 2000

FACILITIES FOR INTRASTATE ACCESS

8. ANCILLARY SERVICES (Cont'd)8.1 GENERAL (Cont'd)8.1.5 Rates and Charges(A) Billing and Collection Services

- | | | | |
|-----|--|-----|-----|
| (1) | Program Development Charge:
per Hour | ICB | (C) |
| (2) | (Reserved for Future Use) | | |
| (3) | (Reserved for Future Use) | | |
| (4) | MTS/WATS/800 Services | | |
| | Call Recording Service:
per Message | ICB | (C) |
| (5) | MTS/WATS/800 Services | | |
| | Message Processing Service:
per Message | ICB | (C) |
| | Assembly and Editing Service:
per Message | ICB | (C) |
| (6) | Call Record Provision Service | | |
| | Via Magnetic Tape, Per Message
Record Transmitted or Received and Rejected | ICB | (C) |
| | Via Direct Interface, Per Message
Record Transmitted or Received and Rejected | ICB | (C) |
| (7) | Message Bill Processing Service | | |
| | Message-Billed without inquiry,
per Message | ICB | (C) |
| (8) | Message Bill Processing Service | | |
| | Bulk-Billed without inquiry,
per Message | ICB | (C) |

Issued: August 30, 2007

Effective: September 29, 2007

Chantel Mosby
Manager, Tariffs and Compliance
Monroe, Louisiana

FACILITIES FOR INTRASTATE ACCESS

RECEIVED

8. ANCILLARY SERVICES (Cont'd)

MAY 10 2000

8.1 GENERAL (Cont'd)

**MISSOURI
Public Service Commission**

8.1.5 Rates and Charges

(A) Billing and Collection Services

- (1) Program Development Charge:
per Hour \$ 94.00
- (2) (Reserved for Future Use)
- (3) (Reserved for Future Use)
- (4) MTS/WATS/800 Services
Call Recording Service:
per Message \$0.0150
- (5) MTS/WATS/800 Services
Message Processing Service:
per Message \$0.0100
Assembly and Editing Service:
per Message \$0.0075
- (6) Call Record Provision Service
Via Magnetic Tape, Per Message
Record Transmitted or Received and Rejected \$0.01
Via Direct Interface, Per Message
Record Transmitted or Received and Rejected \$0.002
- (7) Message Bill Processing Service
Message-Billed without inquiry,
per Message \$0.06433
- (8) Message Bill Processing Service
Bulk-Billed without inquiry,
per Message \$0.0200

FILED

AUG 01 2000
00 - 182

**MISSOURI
Public Service Commission**

Issued: May 10, 2000

Effective: August 1, 2000

CANCELLED
Sept. 29, 2007
Missouri Public
Service Commission

Kenneth Matzdorff
Chief Operating Officer
Kansas City, Missouri

FACILITIES FOR INTRASTATE ACCESS

8. ANCILLARY SERVICES (Cont'd)8.1 GENERAL (Cont'd)8.1.5 Rates and Charges (Cont'd)(A) Billing and Collection Services (Cont'd)

(9)	MTS/WATS/800 Service		
	Bill Rendering Service, per Bill		
	0 to 99,000	ICB	(C)
	99,001 to 143,000	ICB	
	143,001 to 659,999	ICB	
	660,000 to 747,999	ICB	
	Greater than 748,000	ICB	(C)
(10)	(Reserved for Future Use)		
(11)	Specialized Billing Service		
	Specialized Billing		
	per message	ICB	(C)
	Inquiry Service, per message	ICB	(C)
	Adjustment, per adjustment voucher	ICB	(C)
(12)	(Reserved for Future Use)		
(13)	EC Memo, per Account	ICB	(C)
(14)	Record Keeping, per Account	ICB	(C)

(B) In accordance with 8.1.2(C)(2)(c), the rates and charges for the cancellation of an order for Ancillary Services will be developed on an individual case basis.

Issued: August 30, 2007

Effective: September 29, 2007

Chantel Mosby
Manager, Tariffs and Compliance
Monroe, Louisiana

FACILITIES FOR INTRASTATE ACCESS

RECEIVED

8. ANCILLARY SERVICES (Cont'd)

MAY 10 2000

8.1 GENERAL (Cont'd)

**MISSOURI
Public Service Commission**

8.1.5 Rates and Charges (Cont'd)

(A) Billing and Collection Services (Cont'd)

(9) MTS/WATS/800 Service	
Bill Rendering Service, per Bill	
0 to 99,000	\$0.3500
99,001 to 143,000	0.3000
143,001 to 659,999	0.2700
660,000 to 747,999	0.2500
Greater than 748,000	0.2300

(10) (Reserved for Future Use)

(11) Specialized Billing Service	
Specialized Billing	
per message	\$0.0959
Inquiry Service, per message	\$0.0078
Adjustment, per adjustment voucher	\$2.00

(12) (Reserved for Future Use)

(13) EC Memo, per Account \$10.00

(14) Record Keeping, per Account \$0.0300

(B) In accordance with 8.1.2(C)(2)(c), the rates and charges for the cancellation of an order for Ancillary Services will be developed on an individual case basis.

FILED

AUG 01 2000

00-182

**MISSOURI
Public Service Commission**

Issued: May 10, 2000

Effective: August 1, 2000

CANCELLED
Sept. 29, 2007
Missouri Public
Service Commission

Kenneth Matzdorff
Chief Operating Officer
Kansas City, Missouri

FACILITIES FOR INTRASTATE ACCESS

RECEIVED

SECTION 9 TABLE OF CONTENTS

MAY 10 2000
sheet

9. SPECIAL FACILITIES ROUTING OF FIA

MISSOURI
Public Service Commission

9.1	<u>Description of Special Facilities Routing of FIA</u>	272
9.1.1	Diversity	272
9.1.2	Avoidance	272
9.1.3	Cable-Only Facilities	272
9.2	<u>Rates and Charges</u>	273
9.2.1	Diversity	273
9.2.2	Avoidance	273
9.2.3	Diversity and Avoidance Combined	274
9.2.4	Cable-Only Facilities	275

FILED

AUG 01 2000
00-182

MISSOURI
Public Service Commission

FACILITIES FOR INTRASTATE ACCESS

RECEIVED

MAY 10 2000

9. SPECIAL FACILITIES ROUTING OF FIA9.1 Description of Special Facilities Routing of FIA

The FIA provided under this tariff are provided over such routes and facilities as the Telephone Company may elect. Special routing is involved where, in order to comply with requirements specified by the customer, the Telephone Company provides Switched Access, Special Access or Special Federal Government Services in a manner which includes one or more of the following conditions.

**MISSOURI
Public Service Commission**

9.1.1 Diversity

Where two or more FIA must be provided over not less than two different physical routes. Diversity is a Basic Service Element (BSE) under the Telephone company's Open Network Architecture (ONA) plan.

9.1.2 Avoidance

Where a FIA must be provided on a route which avoids specified geographical locations.

9.1.3 Cable-Only Facilities

Where certain voice grade FIA are provided on cable-only facilities to meet the particular needs of a customer. FIA is provided subject to the availability of cable-only facilities. In the event of FIA failure, restoration will be made through the use of any available facilities as selected by the Telephone Company.

Avoidance and Diversity are available on Switched Access as set forth in Section 4, Special Access as set forth in Section 5, and Special Federal Government Services as set forth in Section 11. Cable-only facilities are available for Switched Access as set forth in Section 4, voiceband Special Access as set forth in 5.2.1 and Special Federal Government Services as set forth in Section 11.

In order to identify any special routing requirement, the Telephone Company will provide the ordering customer with the required routing information for each specially routed FIA. If requested by the customer, this information will be provided when the FIA is installed and prior to any subsequent change in routing.

The rates and charges for Special Facilities Routing of FIA as set forth in 9.2 are in addition to all other rates and charges that may be applicable for FIA provided under other sections of this tariff.

FILED

AUG 01 2000

00 - 182

MISSOURI

Public Service Commission

Issued: May 10, 2000

Effective: August 1, 2000

FACILITIES FOR INTRASTATE ACCESS

RECEIVED

9. SPECIAL FACILITIES ROUTING OF FIA (Cont'd)

MAY 10 2000

9.2 Rates and Charges

The rates and charges for Special Facilities Routing of FIA are as follows:

**MISSOURI
Public Service Commission**

9.2.1 Diversity

For each FIA provided in accordance with 9.1.1 preceding, the rates and charges will be developed on an Individual Case Basis and filed following:

(Reserved for Future Use)

9.2.2 Avoidance

For each FIA provided in accordance with 9.1.2 preceding, the rates and charges will be developed on an Individual Case Basis and filed following:

(Reserved for Future Use)

FILED

AUG 01 2000
00 - 182

**MISSOURI
Public Service Commission**

Issued: May 10, 2000

Effective: August 1, 2000

CANCELLED
October 19, 2009
Missouri Public
Service Commission
TN-2010-0092; YI-2010-0175

Kenneth Matzdorff
Chief Operating Officer
Kansas City, Missouri

FACILITIES FOR INTRASTATE ACCESS

RECEIVED

9. SPECIAL FACILITIES ROUTING OF FIA (cont'd)

MAY 10 2000

9.2 Rates and Charges (Cont'd)

**MISSOURI
Public Service Commission**

9.2.3 Diversity and Avoidance Combined

For each FIA provided in accordance with 9.1.1 and 9.1.2 combined, the rates and charges will be developed on an Individual Case Basis and are filed following:

(Reserved for Future Use)

FILED

AUG 01 2000
00-182

**MISSOURI
Public Service Commission**

Issued: May 10, 2000

Effective: August 1, 2000

CANCELLED
October 19, 2009
Missouri Public
Service Commission
TN-2010-0092; YI-2010-0175

Kenneth Matzdorff
Chief Operating Officer
Kansas City, Missouri

FACILITIES FOR INTRASTATE ACCESS

RECEIVED

MAY 10 2000

9. SPECIAL FACILITIES ROUTING OF FIA (cont'd)

9.2 Rates and Charges (cont'd)

9.2.4 Cable-Only Facilities

**MISSOURI
Public Service Commission**

For each FIA provided in accordance with 9.1.3 preceding, the rates and charges will be developed on an Individual Case Basis and filed following:

(Reserved for Future Use)

FILED

AUG 01 2000
00 - 182

**MISSOURI
Public Service Commission**

Issued: May 10, 2000

Effective: August 1, 2000

CANCELLED
October 19, 2009
Missouri Public
Service Commission
TN-2010-0092; YI-2010-0175

Kenneth Matzdorff
Chief Operating Officer
Kansas City, Missouri

FACILITIES FOR INTRASTATE ACCESS

RECEIVED

MAY 10 2000

SECTION 10 TABLE OF CONTENTS

10. SPECIAL CONSTRUCTION

MISSOURI sheet
Public Service Commission

10.1 General..... 278

 10.1.1 Conditions Requiring Special Constructions..... 278

 10.1.2 (Reserved for Future Use)..... 278

 10.1.3 Ownership of Facilities..... 278

 10.1.4 Interval to Provide FIA..... 279

 10.1.5 Special Construction Involving Interstate and Intrastate FIA.. 279

10.2 Liabilities, Charges and Payments..... 279

 10.2.1 General..... 279

 10.2.2 Payment of Charges..... 279

 10.2.3 Start/End of Billing..... 279

 10.2.4 Partial Payments..... 279

 10.2.5 Development of Liabilities and Charges..... 280

 10.2.6 Types of Contingent Liabilities 280

 (A) Maximum Termination Liability..... 280

 (B) Reduction on Maximum Termination Liability..... 281

 10.2.7 Types of Charges..... 282

 (A) Nonrecurring Charges..... 282

 (1) (Reserved for Future Use)..... 282

 (2) Case Preparation Charge..... 282

 (3) Termination Charge..... 282

 (4) Cancellation Charge..... 282

 (5) Expediting Charge..... 282

 (6) Optional Payment Charge..... 283

 (a) Development of Optional Payment Charge..... 283

 (b) Replacement Charge..... 285

 (B) Recurring Charges..... 286

 (1) Excess Capacity Charge..... 287

 (2) (Reserved for Future Use)..... 288

 (3) Charge for Route or Type Other Than Normal..... 288

 (4) Lease Charge..... 291

 10.2.8 Application of Charges..... 291

 (A) Special Construction of Permanent FIA..... 291

 (1) Special Construction When Not Available and There
 is No Other Requirement for Them..... 291

 (2) Special Construction Using a Route or Type of FIA
 Other Than Normal..... 291

 (3) Special Construction of a Greater Quantity of FIA
 Than Necessary to Satisfy the Customer's Order for
 Service..... 292

 (4) Special Construction Expedited at Greater Cost than
 Would Otherwise be Incurred..... 292

 (B) Special Construction of Temporary FIA Order..... 292

FILED

AUG 01 2000
00 - 182

MISSOURI
Public Service Commission

FACILITIES FOR INTRASTATE ACCESS

RECEIVED

MAY 10 2000

SECTION 10 TABLE OF CONTENTS (Cont'd)

MISSOURI
Public Service Commission

10. SPECIAL CONSTRUCTION (Cont'd)

10.3 Deferral of the In-Service of FIA..... 292

10.3.1 General..... 292

10.3.2 Construction Has Not Started..... 292

10.3.3 Construction Has Started But is Not Complete..... 293

 (A) All FIA Are Deferred..... 293

 (B) Some But Not All FIA Are Deferred..... 293

10.3.4 Construction Complete..... 293

FILED

AUG 01 2000
00-182

MISSOURI
Public Service Commission

Issued: May 10, 2000

Effective: August 1, 2000

CANCELLED
October 19, 2009
Missouri Public
Service Commission
TN-2010-0092; YI-2010-0175

Kenneth Matzdorff
Chief Operating Officer
Kansas City, Missouri

FACILITIES FOR INTRASTATE ACCESS

RECEIVED

MAY 10 2000

10. SPECIAL CONSTRUCTION

10.1 General

MISSOURI

Public Service Commission

This section contains the regulations, rates and charges applicable for Special Construction of Telephone Company facilities which are used to provide FIA offered under this tariff.

When Special Construction of FIA is required, the provisions of this section apply in addition to regulations, rates and charges set forth in other sections of this tariff.

10.1.1 Conditions Requiring Special Construction

Special Construction is required when facilities are not available to meet a customer's ASR and one or more of the following conditions exist:

- The Telephone Company has no other requirement for the facilities constructed at the customer's request;
- The customer requests that FIA be furnished using a type of facility, or via a route, other than that which the Telephone Company would otherwise utilize in furnishing the requested FIA;
- The customer requests the construction of more facilities than is required to satisfy its ASR;
- The customer requests construction be expedited resulting in added cost to the Telephone Company;
- The customer requests that temporary facilities be constructed until permanent facilities are available.

10.1.2 (Reserved for Future Use)

10.1.3 Ownership of Facilities

The Telephone Company retains ownership of all specially constructed facilities, except for those facilities constructed by connecting companies or carriers, even though the customer may be required to pay Special Construction charges.

FILED

AUG 01 2000 18 2

MISSOURI Public Service Commission

Issued: May 10, 2000

Effective: August 1, 2000

CANCELLED
October 19, 2009
Missouri Public
Service Commission
TN-2010-0092; YI-2010-0175

Kenneth Matzdorff
Chief Operating Officer
Kansas City, Missouri

FACILITIES FOR INTRASTATE ACCESS

RECEIVED10. SPECIAL CONSTRUCTION (Cont'd)

MAY 10 2000

10.1 General (Cont'd)10.1.4 Interval to Provide FIA

Based on available information and the type of FIA ordered, the Telephone Company will establish a scheduled date for the installation of necessary facilities. The date will be established on an Individual Case Basis and provided to the customer. The Telephone Company will make every reasonable effort to assure that the date is met. However, circumstances beyond the Telephone Company's control (e.g., backorder of components) may force a reschedule, and a new completion date will be established with the customer when appropriate.

MISSOURI
Public Service Commission

10.1.5 Special Construction Involving Interstate and Intrastate FIA

When Special Construction involves facilities used to provide both interstate and intrastate FIA, charges for the portion of the construction used to provide interstate FIA shall be in accordance with the Interstate tariff. Charges for the portion of the construction used to provide intrastate FIA shall be in accordance with this tariff.

10.2 Liabilities, Charges and Payments10.2.1 General

This section describes the various charges and liabilities that apply when the Telephone Company provides Special Construction of FIA, as outlined in 10.1.1 preceding, in accordance with a customer's specific request. Once the customer is notified of all charges and liabilities, the customer must provide the Telephone Company with written approval prior to the start of construction. If more than one condition requiring Special Construction is involved, charges for each condition apply (see Conditions Requiring Special Construction, 10.1.1 preceding).

10.2.2 Payment of Charges

Payment is due upon presentation of a bill for the specially constructed facilities.

10.2.3 Start/End of Billing

Billing of recurring charges for specially constructed FIA starts on the day after the FIA are provided. Billing accrues through and includes the day that the specially constructed FIA are discontinued. Monthly charges will be billed one month in advance.

10.2.4 Partial Payments

The Telephone Company will require a customer which has a proven history of late payments to the Telephone Company, or does not have established credit, to make a partial payment for the portion of the estimated cost of the Special Construction for which the customer is subject to a nonrecurring charge. Partial payments will be requested as costs are incurred and will be credited to the customer's account. Partial payments will not exceed the total nonrecurring charge to the customer for the Special Construction.

FILED

AUG 01 2000

00-182

MISSOURI

Public Service Commission

Issued: May 10, 2000

Effective: August 1, 2000

FACILITIES FOR INTRASTATE ACCESS

RECEIVED10. SPECIAL CONSTRUCTION (Cont'd)

MAY 10 2000

10.2 Liabilities, Charges and Payments (Cont'd)10.2.5 Development of Liabilities and ChargesMISSOURI
Public Service Commission

The customer has the option of accepting the liabilities and charges based on estimated or actual costs. Estimated costs will be used unless the customer notifies the Telephone Company of the selection of the actual cost option in writing prior to the start of Special Construction.

Under the estimated cost option, Special Construction liabilities and charges are developed based on estimated costs and will be filed in this tariff.

Under the actual cost option, if all actual costs are not available prior to the in-service date of the FIA, estimated Special Construction charges will be filed in this tariff. As soon as the actual costs, including costs of maintaining and filing these costs, are subsequently determined, the estimated charges will be adjusted to reflect the actual costs. The filed charges will then reflect actual costs existing at the time the FIA are provided.

10.2.6 Type of Contingent Liability

Depending on the specifics associated with each individual case the following Maximum Termination Liability may be applicable for Special Construction.

(A) Maximum Termination Liability

A MTL has two components, an amount and a specified period of time.

The amount is equal to all nonrecoverable costs less the net salvage value (e.g., depreciation, return, income tax associated with the specially constructed facilities). The amount will be amortized over the average account life of the specially constructed facilities. The standard liability period is the average account life of the Specially Constructed facilities expressed in years.

At the customer's option, an optional liability period shorter than the average account life may be established. If the customer chooses an optional liability period, the MTL amortization schedule will not change. The remaining MTL amount for the period between the expiration of the optional liability period and the expiration of the amortization schedule will be due as a lump sum payment (LS) at the time the optional liability period expires unless the case of Special Construction is extended.

FILED

AUG 01 2000 8 2

MISSOURI
Public Service Commission

Issued: May 10, 2000

Effective: August 1, 2000

CANCELLED
October 19, 2009
Missouri Public
Service Commission
TN-2010-0092; YI-2010-0175

Kenneth Matzdorff
Chief Operating Officer
Kansas City, Missouri

FACILITIES FOR INTRASTATE ACCESS

RECEIVED

10. SPECIAL CONSTRUCTION (Cont'd)

MAY 10 2000

10.2 Liabilities, Charges and Payments (Cont'd)

10.2.6 Type of Contingent Liabilities (Cont'd)

MISSOURI
Public Service Commission

(A) Maximum Termination Liability (Cont'd)

Prior to the expiration of an optional liability period the customer has the option to (A) extend the use of the specially constructed FIA establishing a new liability period, or (B) terminate the case of Special Construction and pay the lump sum payment.

The Telephone Company will notify the customer six months in advance of the expiration date of the optional liability period. The customer must provide the Telephone Company with written notification of its intentions to be received one month prior to expiration of the optional liability period. Failure to do so, and payment of the next month's charges, will result in extension of the case of the Special Construction and the establishment of a new liability period equal to the remaining amortization period. A Case Preparation Charge will always apply if the Special Construction case is extended.

(B) Reduction on Maximum Termination Liability

The time frames for MTL for Special Construction are expressed by an effective date and an expiration date. The MTL will be reduced for each month the Special Construction FIA is in service. For example, if the MTL period is 10 years, for each month in service the MTL would be reduced 1/120th.

FILED

AUG 01 2000
00-182
MISSOURI
Public Service Commission

Issued: May 10, 2000

Effective: August 1, 2000

CANCELLED
October 19, 2009
Missouri Public
Service Commission
TN-2010-0092; YI-2010-0175

Kenneth Matzdorff
Chief Operating Officer
Kansas City, Missouri

FACILITIES FOR INTRASTATE ACCESS

RECEIVED10. SPECIAL CONSTRUCTION (Cont'd)

MAY 10 2000

10.2 Liabilities, Charges and Payments (Cont'd)10.2.7 Types of Charges**MISSOURI
Public Service Commission**

Two categories of charges may be applicable for Special Construction. These charges are nonrecurring charges and recurring charges. These categories are described below.

(A) Nonrecurring Charges

One or more of the following nonrecurring charges may apply for each case of Special Construction: case preparation, termination, cancellation, expediting the construction, or optional payment charges.

- (1) (Reserved for Future Use)
- (2) Case Preparation Charge (GSEC - NASCCP)

The charge for case preparation includes the administrative expense associated with preparing and listing the charges in the tariff. This expense includes such items as: (a) tariff preparation and processing and (b) gross receipts and surcharge taxes.

- (3) Termination Charge (GSEC - NASCT)

A Termination Charge applies when, at the customer's request, FIA provided on specially constructed facilities which have a tariffed Maximum Termination Liability are discontinued prior to the expiration of the liability period.

The charge reflects the unamortized portion of the nonrecoverable cost at the time of termination of the specially constructed FIA adjusted for tax effects, for net salvage and for possible reuse. Administrative costs associated with the specific case of Special Construction and any cost for restoring a location to its original condition are also included. Termination Charges will never exceed the MTL.

- (4) Cancellation Charge (GSEC - NASCC)

If the customer cancels an ASR with which Special Construction is associated prior to the in-service date of the FIA, a Cancellation Charge will apply. The charge will include all nonrecoverable costs less the net salvage value incurred by the Telephone Company up to and including the time of cancellation.

- (5) Expediting Charge (GSEC - NASCE)

An Expediting Charge applies when a customer requests that Special Construction be completed on an expedited basis. The charge is equal to the difference in the estimated cost of construction on an expedited basis and construction without expediting.

FILEDAUG 01 2000
00-182**MISSOURI
Public Service Commission**

Issued: May 10, 2000

Effective: August 1, 2000

FACILITIES FOR INTRASTATE ACCESS

RECEIVED

10. SPECIAL CONSTRUCTION (Cont'd)
 10.2 Liabilities, Charges and Payments (Cont'd)
 10.2.7 Types of Charges (Cont'd)

MAY 10 2000

- (A)
- Nonrecurring Charges
- (Cont'd)

MISSOURI
Public Service Commission

- (6)
- Optional Payment Charge
- (GSEC - NASCOP)

The customer may elect to pay an Optional Payment Charge when it requests Special Construction of facilities utilizing (1) a type of facilities or (2) a route other than that which the Telephone Company would otherwise utilize in furnishing the requested service. Payment of this charge will result in a lower recurring charge for the Special Construction. This election must be made in writing, before Special Construction starts.

If this election is coupled with the actual cost option, the Optional Payment Charge will reflect the actual cost of the specially constructed facilities.

- (a)
- Development of Optional Payment Charge

This charge is equal to the excess installed cost or the total nonrecoverable cost, whichever is less (based on estimated or actual costs as elected by the customer).

Example 1:

Total Installed Cost	\$30,000
Nonrecoverable	20,000
Normal Installed Cost	17,000
Total Installed Cost	\$30,000
Minus Normal Installed Cost	17,000
Equals Excess Installed Cost	13,000
Optional Payment Charge	13,000
Nonrecoverable Cost	\$20,000
Minus Optional Payment Charge	13,000
Equals Investment for MTL Computation	7,000
Remaining Recoverable Excess Installed Cost	\$0

Since the total installed cost is \$30,000 and the normal installed cost would have been \$17,000, the nonrecurring charge (optional payment) is limited to the difference (i.e., \$13,000). A Maximum Termination Liability would then be established to protect the remaining nonrecoverable cost of \$7,000 which is the difference between the total nonrecoverable cost (\$20,000) and the nonrecurring charge (\$13,000). The remaining excess installed cost in this example is zero. In addition, a recurring charge will be developed as set forth in 10.2.7 (B) following.

FILED

AUG 01 2000

MISSOURI 2
Public Service Commission

Issued: May 10, 2000

Effective: August 1, 2000

FACILITIES FOR INTRASTATE ACCESS

RECEIVED10. SPECIAL CONSTRUCTION (Cont'd)

MAY 10 2000

10.2 Liabilities, Charges and Payments (Cont'd)MISSOURI
Public Service Commission10.2.7 Types of Charges (Cont'd)(A) Nonrecurring Charges (Cont'd)(6) Optional Payment Charge (Cont'd)(a) Development of Optional Payment Charge (Cont'd)

Example 2:

Total Installed Cost	\$30,000
Nonrecoverable Cost	10,000
Normal Installed Cost	17,000

Total Installed Cost	\$30,000
Minus Normal Installed Cost	17,000
Equals Excess Installed Cost	13,000
Optional Payment Charge	10,000

Nonrecoverable Cost	\$10,000
Minus Optional Payment Charge	10,000
Equals Investment for MTL Computation	0
Remaining Recoverable Excess Installed Cost	\$ 3,000

The Optional Payment Charge is limited to the nonrecoverable cost. In this example the Optional Payment Charge equals the nonrecoverable cost. Therefore, there is no Maximum Termination Liability. In addition, a recurring charge will be developed as set forth in 10.2.7 (B) following.

FILED

AUG 01 2000

00-182

MISSOURI
Public Service Commission

Issued: May 10, 2000

Effective: August 1, 2000

CANCELLED
October 19, 2009
Missouri Public
Service Commission
TN-2010-0092; YI-2010-0175

Kenneth Matzdorff
Chief Operating Officer
Kansas City, Missouri

FACILITIES FOR INTRASTATE ACCESS

RECEIVED

10. SPECIAL CONSTRUCTION (Cont'd)

MAY 10 2000

10.2 Liabilities, Charges and Payments (Cont'd)

**MISSOURI
Public Service Commission**

10.2.7 Types of Charges (Cont'd)

(A) Nonrecurring Charges (Cont'd)

(6) Optional Payment Charge (Cont'd)

(b) Replacement Charge (GSEC - NESCR)

If any portion of the specially constructed FIA, for which an Optional Payment Charge has been paid, requires replacement involving capital investment, a charge for replacement will apply. This charge will be in the same ratio as the initial Optional Payment Charge was to the installed cost of the specially constructed FIA. The customer will be notified in writing that the replacement is required. Replacement will not be made without the customer's ASR. If any portion of the FIA subject to the replacement charge fails, the FIA will not be restored until the customer orders the replacement.

Example:

Original Total Installed Cost	\$30,000
Original Optional Payment Charge	\$15,000
Subsequent Cost of Replacement	\$ 2,000

Original Optional Payment Charge x	
<u>Replacement Cost</u>	
Total Installed Cost	

$\frac{\$15,000 \times \$2,000}{\$30,000} = 1,000$	
--	--

Replacement Charge	\$ 1,000
--------------------	----------

FILED

AUG 01 2000
00 - 182

**MISSOURI
Public Service Commission**

FACILITIES FOR INTRASTATE ACCESS

RECEIVED

- 10. SPECIAL CONSTRUCTION (Cont'd)
- 10.2 Liabilities, Charges and Payments (Cont'd)
- 10.2.7 Types of Charges (Cont'd)
- (B) Recurring Charges

MAY 10 2000

MISSOURI
Public Service Commission

These charges apply on a monthly or annual basis for specially constructed FIA. There are three conditions for which recurring charges apply:

- When a customer requests the construction of more facilities than are necessary to provide the FIA currently ordered.
- When a customer requests a facility route or type other than that which the Telephone Company would utilize to provide FIA.
- When a customer's request results in the Telephone Company leasing transmission or other equipment from private vendors to provide FIA (Lease Charge).

FILED

AUG 01 2000
00-182

MISSOURI
Public Service Commission

Issued: May 10, 2000

Effective: August 1, 2000

CANCELLED
October 19, 2009
Missouri Public
Service Commission
TN-2010-0092; YI-2010-0175

Kenneth Matzdorff
Chief Operating Officer
Kansas City, Missouri

FACILITIES FOR INTRASTATE ACCESS

RECEIVED

- 10. SPECIAL CONSTRUCTION (Cont'd)
- 10.2 Liabilities, Charges and Payments (Cont'd)
- 10.2.7 Types of Charges (Cont'd)
- (B) Recurring Charges (Cont'd)
- (1) Excess Capacity Charge

MAY 10 2000

MISSOURI
Public Service Commission

An Excess Capacity Charge applies when the customer requests more facilities be constructed than are required to satisfy the customer's ASR. The charge is based on the estimated cost difference between the facilities constructed at the customer's request and the facilities actually required to meet the customer's ASR.

Example:

A customer has an immediate FIA requirement which would require a 100 pair cable but requests the installation of a 300 pair cable to allow for growth.

Total Installed Cost (300 Pair)	\$2,500
Estimated Annual Cost	\$ 920
Estimated Installed Cost (100 Pair)	\$1,000
Estimated Annual Cost	\$ 368

Excess Recurring Charge: Annually \$920 - \$368 = \$552

Monthly \$552
12 = \$46

This charge applies until such time as the customer orders sufficient FIA to necessitate use of a larger size cable (e.g., 200 pair cable). At that time the recurring charge is adjusted as indicated in the following example:

Total Installed Cost (300 Pair)	\$2,500
Estimated Annual Cost	\$ 920
Estimated Installed Cost (200 Pair)	\$1,900
Estimated Annual Cost	\$ 683

Excess Recurring Charge: Annually \$920 - \$683 = \$237

Monthly \$237
12 = \$19.75

The charge is revised in this manner until the number of FIA being provided would require a 300 pair cable, at which time the Excess Capacity Charge is no longer applied. The charge would be reapplied if the number of FIA declined to a level which would not require a 300 pair cable.

Such charges will continue to apply to all facilities held in abeyance until the period of termination liability expires. If facilities are still held in abeyance after the termination liability expires, a new schedule of rates will be calculated and such rates will apply as long as facilities are held in abeyance for the customer.

FILED

AUG 01 2000
00 - 182

MISSOURI
Public Service Commission

Issued: May 10, 2000

Effective: August 1, 2000

CANCELLED
October 19, 2009
Missouri Public
Service Commission
TN-2010-0092; YI-2010-0175

Kenneth Matzdorff
Chief Operating Officer
Kansas City, Missouri

FACILITIES FOR INTRASTATE ACCESS

RECEIVED

- 10. SPECIAL CONSTRUCTION (Cont'd)
- 10.2 Liabilities, Charges and Payments (Cont'd)
- 10.2.7 Types of Charges (Cont'd)
- (B) Recurring Charges (Cont'd)

MAY 10 2000

MISSOURI
Public Service Commission

- (2) (Reserved for Future Use)
- (3) Charge for Route or Type Other Than Normal (GSEC - ASCR/T)

When the customer requests Special Construction using a route or type of FIA other than that which the Telephone Company would normally use, a recurring charge is applicable. The charge is the difference between the estimated recurring costs of the specially constructed FIA and the estimated recurring costs of the FIA the Telephone Company would normally use. The charge will be no greater than the recurring costs of the specially constructed FIA.

- (a) If the customer elects to pay an Optional Payment Charge, the portion of the recurring charge for the excess investment covered by the optional payment excludes capital cost items (depreciation, return on investment and Federal income tax on that return). The remaining recurring expense cost items associated with the optional payment (maintenance, administration, and other taxes) are increased by a ten percent management fee and will be included in the recurring charge.

The portion of any recurring charge associated with any remaining Special Construction investment will include both capital and expense costs. The ten percent management fee is not applied to this portion of the recurring charge.

FILED

AUG 01 2000
00-182

MISSOURI
Public Service Commission

Issued: May 10, 2000

Effective: August 1, 2000

CANCELLED
 October 19, 2009
 Missouri Public
 Service Commission
 TN-2010-0092; YI-2010-0175

Kenneth Matzdorff
 Chief Operating Officer
 Kansas City, Missouri

FACILITIES FOR INTRASTATE ACCESS

RECEIVED

10. SPECIAL CONSTRUCTION (Cont'd)
 10.2 Liabilities, Charges and Payments (Cont'd)
 10.2.7 Types of Charges (Cont'd)
 (B) Recurring Charges (Cont'd)

MAY 10 2000

MISSOURI
Public Service Commission

- (3) Charge for Route or Type Other Than Normal (Cont'd)
 (a) (Cont'd)

DEVELOPMENT OF RECURRING MONTHLY CHARGE FOR OPTIONAL PAYMENTS

For example 1 see 10.2.7(A) (6) (a)

SPECIAL ROUTE OR TYPE OF FIANORMAL

	A	B	C	D
	Optional Payment Nonrecurring Charge For Special Const. FIA	Specially Constructed FIA Less Nonrecurring Charges	Existing Facilities	Normal Route/Type Facilities
	\$13,000	\$17,000		\$17,000
1. Depreciation	-	1,122		408
2. Federal Income Tax and Return	-	2,142		2,346
3. Maintenance	1,131	1,479		799
4. Administration	455	595		595
5. Other Taxes	286	37		374
6. Sub Total	1,872	-	-	-
7. 10% x Line 6	187	-	-	-
8. Totals	(A) \$ 2,059	(B) \$ 5,712	(C)	(D) \$ 4,522

A + B = \$7,771

A + B + C = 7,771

(A + B + C) - D = 3,249

Excess Recurring Charge:* Annually \$3,249.00
 Monthly \$ 270.75

*The lower of (A+B+C)-D, or (A+B)

FILED

AUG 01 2000

00 - 182

MISSOURI
Public Service Commission

Issued: May 10, 2000

Effective: August 1, 2000

CANCELLED
 October 19, 2009
 Missouri Public
 Service Commission
 TN-2010-0092; YI-2010-0175

Kenneth Matzdorff
 Chief Operating Officer
 Kansas City, Missouri

FACILITIES FOR INTRASTATE ACCESS

RECEIVED

- 10. SPECIAL CONSTRUCTION (Cont'd)
- 10.2 Liabilities, Charges and Payments (Cont'd)
- 10.2.7 Types of Charges (Cont'd)
- (B) Recurring Charges (Cont'd)

MAY 10 2000

MISSOURI
Public Service Commission

- (3) Charge for Route or Type Other Than Normal (Cont'd)
- (a) (Cont'd)

For example 2 see 10.2.7(A) (6) (a)

	<u>SPECIAL ROUTE OR TYPE OF FIA</u>				
	<u>NORMAL</u>	A	B	C	D
	Optional Payment Nonrecurring Charge For Special Const. FIA	Specially Constructed FIA Less Nonrecurring Charges	Existing Facilities	Normal Route/Type Facilities	
	\$10,000	\$20,000			\$17,000
1. Depreciation	-	1,320			408
2. Federal Income Tax and Return	-	2,520			2,346
3. Maintenance	870	1,740			799
4. Administration	350	700			595
5. Other Taxes	220	440			374
6. Sub Total	1,440	-	-		-
7. 10% x Line 6	144	-	-		-
8. Totals	(A) \$ 1,584	(B) \$ 6,720	(C)		(D) \$ 4,522

A + B = \$8,304
 A + B + C = 8,304
 (A + B + C) - D = 3,782

Excess Recurring Charge:* Annually \$3,782.00
 Monthly \$ 315.17

*The lower of (A+B+C)-D, or (A+B)

FILED

AUG 01 2000
 00 - 182
 MISSOURI
 Public Service Commission

Issued: May 10, 2000

Effective: August 1, 2000

CANCELLED
 October 19, 2009
 Missouri Public
 Service Commission
 TN-2010-0092; YI-2010-0175

Kenneth Matzdorff
 Chief Operating Officer
 Kansas City, Missouri

FACILITIES FOR INTRASTATE ACCESS

RECEIVED10. SPECIAL CONSTRUCTION (Cont'd)

MAY 10 2000

10.2 Liabilities, Charges and Payments (Cont'd)MISSOURI
Public Service Commission10.2.7 Types of Charges (Cont'd)(B) Recurring Charges (Cont'd)(3) Charge for Route or Type Other Than Normal (Cont'd)

(b) If the customer has elected the actual cost option, the recurring charge will be adjusted to reflect the actual cost of the new construction when the cost is determined. This adjusted recurring charge is applicable from the start of FIA.

(4) Lease Charge (GSEC - ASCL)

A Lease Charge applies when the Telephone Company leases equipment (e.g., portable microwave equipment) in order to provide FIA to meet the customer's requirements. The amount of the charge is the net added cost to the Telephone Company caused by the lease.

10.2.8 Application of Charges

The charges for Special Construction are those charges which are in effect for the period that the Special Construction is furnished. If the charges for a period covered by a bill change after the bill has been rendered, the bill will be adjusted to reflect the new charges. Charges are based on Special Construction of (A) permanent FIA or (B) temporary FIA.

(A) Special Construction of Permanent FIA(1) Special Construction When Not Available and There is No Other Requirement for Them

When permanent FIA are not available and the Telephone Company constructs them and there is no other Telephone Company need for the specially constructed FIA, a nonrecurring charge, and a Maximum Termination Liability may be applicable.

(2) Special Construction Using a Route or Type of FIA Other ThanNormal

When the specially constructed FIA involve a route or type of FIA other than that which the Telephone Company would ordinarily use, charges are based on the difference between the estimated costs of the specially constructed FIA and those the Telephone Company would ordinarily use. A nonrecurring charge, a recurring charge, and a Maximum Termination Liability may be applicable.

FILEDAUG 01 2000
18 2MISSOURI
Public Service Commission

Issued: May 10, 2000

Effective: August 1, 2000

FACILITIES FOR INTRASTATE ACCESS

RECEIVED

MAY 10 2000

10. SPECIAL CONSTRUCTION (Cont'd)

10.2 Liabilities, Charges and Payments (Cont'd)

10.2.8 Application of Charges (Cont'd)

MISSOURI
Public Service Commission

(A) Special Construction of Permanent FIA (Cont'd)

(3) Special Construction of a Greater Quantity of FIA Than Necessary to Satisfy the Customer's Order for Service

When the Telephone Company constructs more FIA than is required to satisfy the customer's ASR, additional charges will apply. These charges may include a nonrecurring charge, a recurring charge, and a Maximum Termination Liability.

(4) Special Construction Expedited at Greater Cost Than Would Otherwise be Incurred

When construction is expedited resulting in added costs, a nonrecurring Expediting Charge applies.

(B) Special Construction of Temporary FIA Order

When permanent FIA are not available and temporary FIA are constructed pending the construction of permanent FIA, a nonrecurring charge, and a Maximum Termination Liability may be applicable.

10.3 Deferral of the In-Service Date of FIA

10.3.1 General

The customer may request the Telephone Company to defer the in-service date of FIA on specially constructed FIA subject to the provisions as set forth in 3.2.2(A) preceding. If the deferral is not in compliance with the provisions as set forth in 3.2.2(A), the Special Construction case is considered to be canceled and cancellation charges apply. Requests for deferral must be in writing and are subject to the following regulations.

10.3.2 Construction Has Not Started

If the Telephone Company has not incurred any costs (e.g., engineering and/or installation) before receiving the customer's request for deferral, no charge applies other than the Case Preparation Charge. However, the original quotation is subject to Telephone Company review at the time of reinstatement to determine if the original charges are still valid. Any change in liabilities and charges requires the concurrence of the customer in writing. Additional Case Preparation Charges will also apply.

FILED

AUG 01 2000
00-182

MISSOURI
Public Service Commission

FACILITIES FOR INTRASTATE ACCESS

RECEIVED

10. SPECIAL CONSTRUCTION (Cont'd)

MAY 10 2000

10.3 Deferral of the In-Service of FIA (Cont'd)

**MISSOURI
Public Service Commission**

10.3.3 Construction Has Started But Is Not Complete

If the construction of FIA has started, but has not been completed, before the Telephone Company receives the customer's request for deferral, charges apply. The charges vary depending on whether all or some of the FIA ordered are deferred.

(A) All FIA Are Deferred

When all FIA involving Special Construction are deferred, a charge equal to the costs incurred during each month of the deferral applies. Those costs include the recurring costs for that portion of the FIA already completed and any other costs associated with the deferral. The Case Preparation Charge also applies.

(B) Some But Not All FIA Are Deferred

When some, but not all, FIA utilizing the specially constructed FIA are deferred, the Special Construction case will be completed. Maximum Termination Liability will apply in addition to Case Preparation Charges and any recurring charges associated with the Special Construction.

10.3.4 Construction Complete

If the construction of FIA has been completed before the Telephone Company receives the customer's request for deferral, the Case Preparation Charge as originally determined, will apply and any recurring charges associated with the Special Construction. The maximum termination liability period will begin when the customer accepts the service.

FILED

AUG 01 2000

00-182

**MISSOURI
Public Service Commission**

Issued: May 10, 2000

Effective: August 1, 2000

CANCELLED
October 19, 2009
Missouri Public
Service Commission
TN-2010-0092; YI-2010-0175

Kenneth Matzdorff
Chief Operating Officer
Kansas City, Missouri

FACILITIES FOR INTRASTATE ACCESS

RECEIVED

SECTION 11 TABLE OF CONTENTS

11. <u>SPECIAL FEDERAL GOVERNMENT FIA</u>	MAY 10 2000	Sheet
11.1 <u>General</u>		295
11.2 <u>Emergency Conditions</u>	MISSOURI Public Service Commission	295
11.3 <u>Intervals to Provide FIA</u>		295
11.4 (Reserved for Future Use)		295
11.5 <u>Safeguarding of FIA</u>		296
11.5.1 (Reserved for Future Use)		296
11.5.2 FIA Availability		296
11.6 <u>Federal Government Regulations</u>		296
11.7 (Reserved for Future Use)		296
11.8 <u>FIA Offerings to the Federal Government</u>		296
11.8.1 Type and Description		296
(A) Voiceband Special Access		296
(1) Voice Grade Secure Communications Type I		296
(2) Voice Grade Secure Communications Type II		297
(3) Voice Grade Secure Communications Type III		297
(4) Voice Grade Secure Communications Type IV		298
(B) Special Wideband Digital Special Access		298
(1) Wideband Secure Communications Type I		298
(2) Wideband Secure Communications Type II		298
(3) Wideband Secure Communications Type III		298
11.8.2 Mileage Application		298
11.8.3 Rates and Charges		299
(A) Voiceband Special Access		299
(B) Special Wideband Digital Special Access		299
(C) Move Charges		300

FILED

AUG 01 2000
00-182
MISSOURI
Public Service Commission

Issued: May 10, 2000

Effective: August 1, 2000

CANCELLED
October 19, 2009
Missouri Public
Service Commission
TN-2010-0092; YI-2010-0175

Kenneth Matzdorff
Chief Operating Officer
Kansas City, Missouri

FACILITIES FOR INTRASTATE ACCESS

RECEIVED

MAY 10 2000

11. SPECIAL FEDERAL GOVERNMENT FIA11.1 General

This section covers FIA that are provided for use only by agencies or branches of the Federal Government and other users authorized by the Federal Government. FIA provided to state emergency operations centers are included. These FIA provide for command and control communications, including communications for national security, emergency preparedness and presidential requirements. They are required to assure continuity of Government in emergency and crisis situations and to provide for national security.

FIA for command and control communications and for national security and emergency preparedness are sometimes required within a short time frame. These provisions are especially needed to meet presidential requirements or in response to natural, man made, or declared emergencies. Requirements of this type cannot be forecasted and are usually needed for a relatively short period. The provision of FIA under these conditions may require the availability of facilities, such as portable microwave equipment, etc., which are provided on a temporary basis.

11.2 Emergency Conditions

These FIA will be provided on the date requested or as soon as possible thereafter when the emergency falls into one of the following categories:

State of crisis declared by the National Command Authorities (includes commitments made to the National Communications System in the "National Plan for Emergencies and Major Disasters").

Efforts to protect endangered U.S. personnel or property both in the U.S. and abroad (includes space vehicle recovery and protection efforts).

Communications requirements resulting from hostile action, a major disaster or a major civil disturbance.

The Director (Cabinet level) of a Federal Department, Commander of a Unified/Specified Command, or Head of a Military Department has certified that a communications requirement is so critical to the protection of life and property or to the National Defense that it must be processed immediately.

Political unrest in foreign countries which affect the National Interest.

Presidential Service.

11.3 Intervals to Provide FIA

ASRs may be placed under the provisions set forth in 3.2.1 preceding.

11.4 (Reserved for Future Use)

FILEDAUG 01 2000
00 - 182MISSOURI
Public Service Commission

Issued: May 10, 2000

Effective: August 1, 2000

FACILITIES FOR INTRASTATE ACCESS

RECEIVED11. SPECIAL FEDERAL GOVERNMENT FIA (Cont'd)

MAY 10 2000

11.5 Safeguarding of FIA

11.5.1 (Reserved for Future Use)

11.5.2 FIA Availability**MISSOURI
Public Service Commission**

In order to insure communications during periods of emergency, the Telephone Company will (within the limits of good management) make available the necessary facilities to restore FIA in the event of damage or to provide temporary emergency FIA.

In order to meet the requirements of agencies or branches of the Federal Government, the Telephone Company may utilize Government-owned facilities, when necessary, to provide FIA.

11.6 Federal Government Regulations

FIA provided to the Federal Government will be billed in arrears, as required by Federal procurement or disbursement regulations, or as established by law. ICs providing service to the Federal Government are not entitled to the benefits of those laws or regulations providing for billing the Federal Government in arrears.

11.7 (Reserved for Future Use)

11.8 FIA Offerings to the Federal Government

The following FIA are provided only for agencies or branches of the Federal Government. Access Services provided to the Federal Government but not specified in the following will be provided in accordance with the regulations and at the rates contained in other sections of this tariff.

11.8.1 Type and Description(A) Voiceband Special Access(1) Voice Grade Secure Communications Type I

Approximate bandwidth of 10-50000 Hz. Furnished for two-point secure communications on two-wire or four-wire metallic facilities between two or more customer designated locations and an end user's premises. Special Access is conditioned as follows:

T-3 Conditioning - The absolute loss (referenced to one milliwatt) with respect to frequency shall not exceed:

15 dB at 10 Hz
13 dB at 100 Hz
12 dB at 1000 Hz
20 dB at 10000 Hz
30 dB at 50000 Hz

FILEDAUG 01 2000
00-182**MISSOURI
Public Service Commission**

Issued: May 10, 2000

Effective: August 1, 2000

CANCELLED
October 19, 2009
Missouri Public
Service Commission
TN-2010-0092; YI-2010-0175

Kenneth Matzdorff
Chief Operating Officer
Kansas City, Missouri

FACILITIES FOR INTRASTATE ACCESS

RECEIVED

MAY 10 2000

11. SPECIAL FEDERAL GOVERNMENT FIA (Cont'd)11.8 FIA Offerings to the Federal Government (Cont'd)11.8.1 Type and Description (Cont'd)**MISSOURI
Public Service Commission**(A) Voiceband Special Access (Cont'd)(1) Voice Grade Secure Communications Type I (Cont'd)

Additional conditioning (available in one or two directions on four-wire facilities only) to provide the following characteristics:

The absolute loss (referenced to one milliwatt) with respect to frequency shall not exceed:

- 0 dB at 1000 Hz
- + 1 dB between 1000 Hz and 40000 Hz
- + 2 dB between 10 Hz and 50000 Hz (+ means more loss)

The net loss of the conditioned Special Access (with or without additional conditioning) shall not vary by more than 4 dB at 1000 Hz from the levels specified above. Voice frequency signaling or supervisory tones can be transmitted.

(2) Voice Grade Secure Communications Type II

Approximate bandwidth 10-50000 Hz. Furnished on four-wire metallic facilities for duplex operation for two-point secure communication between a customer designated location and an end user's premises. Special Access is conditioned as follows:

G-1 Conditioning - The absolute loss with respect to frequency and the net loss variation shall be the same as Voice Grade Secure Communications Type I Special Access without additional conditioning. Voice frequency signaling or supervisory tones can be transmitted.

(3) Voice Grade Secure Communications Type III

Approximate bandwidth 10-50000 Hz. Furnished on four-wire metallic facilities for duplex operation for two-point secure communication between a customer designated location and an end user's premises. Special Access is conditioned as follows:

G-2 Conditioning - The absolute loss with respect to frequency and the net loss variation from the customer designated location to the end user's premises shall be the same as Voice Grade Secure Communications Type I Special Access without additional conditioning; and from the end user's premises to the customer designated location shall be the same as Voice Grade Secure Communications Type I Special Access with additional conditioning. Voice frequency signaling or supervisory tones can be transmitted.

FILED

AUG 01 2000 2

**MISSOURI
Public Service Commission**

Issued: May 10, 2000

Effective: August 1, 2000

FACILITIES FOR INTRASTATE ACCESS

RECEIVED

MAY 10 2000

11. SPECIAL FEDERAL GOVERNMENT FIA (Cont'd)11.8 FIA Offerings to the Federal Government (Cont'd)11.8.1 Type and Description (Cont'd)**MISSOURI
Public Service Commission**(A) Voiceband Special Access (Cont'd)(4) Voice Grade Secure Communications Type IV

Approximate bandwidth 10-50000 Hz. Furnished on four-wire metallic facilities for duplex operations for two-point secure communications between two customer designated locations. Special Access is conditioned as follows:

G-3 Conditioning - The absolute loss with respect to frequency and the net loss variation shall be the same in both directions of transmission as Voice Grade Secure Communications Type I Special Access with additional conditioning. Voice frequency signaling or supervisory tones can be transmitted.

(B) Special Wideband Digital Special Access

Special Access arrangements for secured communications to accommodate the transmission of binary digital baseband signals in a random polar format.

(1) Wideband Secure Communications Type I

For transmission at the rate of 18,750 bits per second.

(2) Wideband Secure Communications Type II

For transmission at the rate of 50,000 bits per second.

(3) Wideband Secure Communications Type III

To accommodate the transmission of restored polar two-level facsimile signals with a minimum signal element width of 20 microseconds at a rate of 50,000 bits per second.

To accommodate the transmission of binary digital baseband signals in a random polar format at the rate of 50,000 bits per second.

11.8.2 Mileage Application

Mileage for rate application is the airline distance measured between the two related Special Access terminating points (i.e., customer designated location and end user premises).

FILEDAUG 01 2000
00-182**MISSOURI
Public Service Commission**

Issued: May 10, 2000

Effective: August 1, 2000

FACILITIES FOR INTRASTATE ACCESS

RECEIVED

11. SPECIAL FEDERAL GOVERNMENT FIA (Cont'd)

MAY 10 2000

11.8 FIA Offerings to the Federal Government (Cont'd)

**MISSOURI
Public Service Commission**

11.8.3 Rates and Charges

Notification will be made to the FCC that Special Federal Government FIA will be provided in accordance with Special Permission No. 83-867.

(A) Voiceband Special Access

The provision of T-3 and G conditioned Special Access contemplates station and tandem switching operations using customer provided equipment, as well as Special Access. Separate narrowband or voice grade Special Access, where required by the customer provided equipment or switching operation, are furnished in accordance with the applicable sections of this tariff.

<u>Voice Grade Secure Communications</u>	<u>Monthly Rates</u>	<u>Nonrecurring Charges</u>	<u>Termination Charges</u>
Type I, each T-3 Conditioning		ICB rates and charges apply	
Additional Conditioning, per Special Access termination		ICB rates and charges apply	
Type II, each G-1 Conditioning		ICB rates and charges apply	
Type III, each G-2 Conditioning		ICB rates and charges apply	
Additional Conditioning, per Special Access termination		ICB rates and charges apply	
Type IV, each G-3 Conditioning		ICB rates and charges apply	
Additional Conditioning, per Special Access termination		ICB rates and charges apply	

(B) Special Wideband Digital Special Access

<u>Wideband Secure Communications</u>	<u>Monthly Rates</u>	<u>Nonrecurring Charges</u>	<u>Termination Charges</u>
Type I, each		ICB rates and charges apply	
Type II, each		ICB rates and charges apply	
Type III, each		ICB rates and charges apply	

FILED

AUG 01 2000
00-182

**MISSOURI
Public Service Commission**

Issued: May 10, 2000

Effective: August 1, 2000

CANCELLED
October 19, 2009
Missouri Public
Service Commission
TN-2010-0092; YI-2010-0175

Kenneth Matzdorff
Chief Operating Officer
Kansas City, Missouri

FACILITIES FOR INTRASTATE ACCESS

RECEIVED

11. SPECIAL FEDERAL GOVERNMENT FIA (Cont'd)

MAY 10 2000

11.8 FIA Offerings to the Federal Government (Cont'd)

MISSOURI
Public Service Commission

11.8.3 Rates and Charges (Cont'd)

(C) Move Charges

When a Special Access requiring T-3 conditioning, T-3 additional conditioning, or a Special Access requiring G conditioning as set forth in (A) preceding, is moved to a different building, the nonrecurring charge applies; when moved to a new location in the same building, a charge of one-half the nonrecurring charge applies.

When any FIA for which a termination charge is specified is moved and is installed at a new location the customer may elect:

- (1) to pay the unexpired portion of the termination charge for the FIA, if any, with the application of a nonrecurring charge and the establishment of a new termination charge for such FIA at the new location, or
- (2) to continue the FIA subject to the unexpired portion of the termination charge, if any, and pay the estimated costs of moving such FIA, provided that the customer requests these charges be quoted prior to ordering the FIA move. Charges for moving such FIA will be based on estimated costs attributable to the move.

Move charges include the estimated costs of removal, restoration of FIA necessitated by the move, transportation, storage, reinstallation, engineering, labor, supervision, materials, administration, taxes, and any other specific items of cost directly attributable to the move.

FILED

AUG 01 2000

00 - 182

MISSOURI
Public Service Commission

Issued: May 10, 2000

Effective: August 1, 2000

CANCELLED
October 19, 2009
Missouri Public
Service Commission
TN-2010-0092; YI-2010-0175

Kenneth Matzdorff
Chief Operating Officer
Kansas City, Missouri

FACILITIES FOR INTRASTATE ACCESS

RECEIVED

SECTION 12 TABLE OF CONTENTS

MAY 10 2000

12.	<u>CARRIER COMMON LINE SERVICE</u>	Sheet
12.1	<u>General</u>	302
12.2	<u>Description of Carrier Common Line Charges</u>	302
12.2.1	Description	302
12.2.2	Limitations	302
	(A) Exclusions	302
	(B) WATS/WATS-type Access Lines	302
12.3	<u>Obligations of the Customer</u>	303
12.3.1	Switched Access Service Requirement	303
12.3.2	Supervision	303
12.4	<u>Rate Regulations</u>	303
12.4.1	Description and Application of Rates	303
	(A) Billing of Charges	303
	(B) Measuring and Recording of Call Detail	303
	(C) Unmeasured Feature FGA, FGB, BSA-A and BSA-B Usage	303
	(D) Mixed Interstate and Intrastate Usage	304
	(E) Determination of Premium Charges	304
12.4.2	Determination of Usage Subject to Carrier Common Line Charges	306
	(A) Determination of Jurisdiction	306
	(B) Cases Involving Usage Recording By the Customer	306
	(C) Local Exchange Access and Enhanced Services Exemption	306
12.4.3	Resold Services	307
	(A) Scope	307
	(B) Customer Obligations Concerning the Resale of MTS/MTS-type Services	307
	(C) Resale Documentation Provided By the Customer	308
	(D) Rate Regulations Concerning the Resale of MTS/MTS-type Services	308
	(1) Apportionment and Adjustment of Resold Minutes of Use	308
	(a) Originating Services	308
	(b) Terminating Services	309
	(2) Same State/Telephone Company/Exchange Limitation	309
	(3) Direct and Indirect Connections	310
	(4) Access Groups and BSAs - Nonequal Access Offices Only	310
	(5) Access Groups and BSAs - Equal Access Offices Only	311
	(6) Access Groups and BSAs - Nonequal Access and Equal Access Offices	311
	(7) When the Adjustment Will Be Applied to Customer Bills	312
	(8) Conversion of Billed Usage to Minutes	312
	(9) Mixed Interstate and Intrastate Usage	312
12.5	<u>Rates and Charges</u>	313

MISSOURI Public Service Commission

FILED

AUG 01 2000 8 2

MISSOURI Public Service Commission

Issued: May 10, 2000

Effective: August 1, 2000

CANCELLED
October 19, 2009
Missouri Public
Service Commission
TN-2010-0092; YI-2010-0175

Kenneth Matzdorff
Chief Operating Officer
Kansas City, Missouri

RECEIVED

FACILITIES FOR INTRASTATE ACCESS

MAY 10 2000

12. CARRIER COMMON LINE SERVICE

12.1 General

Carrier Common Line charges are applicable in conjunction with Switched Access Services provided in Section 4 of this tariff.

MISSOURI
Public Service Commission

12.2 Description of Carrier Common Line Access Service

12.2.1 Description

Carrier Common Line charges compensate the Telephone Company for the use of Telephone Company provided common lines by customers for access to end users in furnishing Intrastate Communications.

A Special Access Surcharge will apply to intrastate Special Access service provided by the Telephone Company to a customer, in accordance with regulations as in 5.6.9.

12.2.2 Limitations

(A) Exclusions

Neither a telephone number nor detail billing are provided with Carrier Common Line access. Additionally, directory listings and intercept arrangements are not included in the rates and charges for Carrier Common Line access.

(B) WATS/WATS-type Access Lines

Where Switched Access Services are connected with Special Access Services at Telephone Company designated WATS Serving Offices for the provision of WATS/WATS-type Services, Switched Access Service minutes which are carried on that end of the service (i.e., originating minutes for outward WATS/WATS-type services and terminating minutes for inward WATS/WATS-type services) shall not be assessed Carrier Common Line per minute charges with the following exception. Carrier Common Line per minute charges shall apply when FGA, FGB, BSA-A or BSA-B Switched Access is ordered from a nonequal access Telephone Company end office or access tandem that does not have measurement capabilities, (i.e., cannot create an Automatic Message Accounting record).

FILED

AUG 01 2000
00 - 182

MISSOURI
Public Service Commission

Issued: May 10, 2000

Effective: August 1, 2000

FACILITIES FOR INTRASTATE ACCESS

RECEIVED12. CARRIER COMMON LINE SERVICE (Cont'd)

MAY 10 2000

12.3 Obligations of the Customer12.3.1 Switched Access Service Requirement

Switched Access Service associated with the Carrier Common Line charges shall be ordered by the customer under other sections of this tariff.

**MISSOURI
Public Service Commission**

12.3.2 Supervision

The customer facilities at the premises of the ordering customer shall provide the necessary on-hook and off-hook supervision.

12.4 Rate Regulations12.4.1 Description and Application of Rates(A) Billing of Charges

Carrier Common Line charges will be billed to each Switched Access Service provided under this tariff in accordance with the regulations as in (E) following, except as in (D) following and 12.4.3(D).

(B) Measuring and Recording of Call Detail

When access minutes are used to determine Carrier Common Line charges, they will be accumulated using call detail recorded by Telephone Company equipment except as in (C) following and FGC or BSA-C operator and automated operator services systems call detail such as pay telephone sent-paid, operator-DDD, operator-person, collect, credit card, third number and/or other like calls recorded by the customer. The Telephone Company measuring and recording equipment, except as in (C) following, will be associated with end office or access tandem switching equipment and will record each originating and terminating access minute, as described in 4.5.2(O), where answer supervision is received. The accumulated access minutes will be summed on a line by line or trunk by trunk basis, by access group or by end office, whichever type of account is used by the Telephone Company, for each customer and then rounded to the nearest minute.

(C) Unmeasured FGA, FGB, BSA-A and BSA-B Usage

When Carrier Common Line charges are applicable in association with FGA, FGB, BSA-A or BSA-B Switched Access Service in Telephone Company offices that are not equipped for measurement capabilities, an assumed average intrastate access minutes will be used to determine Carrier Common Line charges. These assumed access minutes are as in 4.5.2(O)(3) and 4.6.7.

FILED

AUG 01 2000
00 - 182

**MISSOURI
Public Service Commission**

Issued: May 10, 2000

Effective: August 1, 2000

CANCELLED
October 19, 2009
Missouri Public
Service Commission
TN-2010-0092; YI-2010-0175

Kenneth Matzdorff
Chief Operating Officer
Kansas City, Missouri

FACILITIES FOR INTRASTATE ACCESS

RECEIVED12. CARRIER COMMON LINE SERVICE (Cont'd)

MAY 10 2000

12.4 Rate Regulations (Cont'd)12.4.1 Description and Application of Rates (Cont'd)**MISSOURI
Public Service Commission**(D) Mixed Interstate and Intrastate Usage

When the customer reports interstate and intrastate use of Switched Access Service, Carrier Common Line charges, as set forth in 12.5, will be billed only to intrastate Switched Access Service access minutes based on the data reported by the customer, as set forth in 4.3.2 and 4.5.2(J), except where the Telephone Company is billing according to actual usage by jurisdiction. Intrastate Switched Access Service access minutes will, after adjustment as set forth in 12.4.3(D), when necessary, be used to determine Carrier Common Line charges as set forth in (E) following.

(E) Determination of Premium Charges

The application of premium rates for a specific customer, as described in 4.5.2(N)(1), is dependent upon the Switched Access feature group and the availability of equal access capabilities in the end office or the WATS Serving Office from which the service is provided.

After the adjustments, as set forth in (D) preceding and 12.4.3(D), have been applied, when necessary, to Switched Access Service access minutes, charges for the involved customer account will be determined as follows:

- (1) Premium rated Switched Access Service minutes subject to Carrier Common Line charges will be multiplied by the premium access per minute rate as set forth in 12.5.
- (2) (Reserved for Future Use)
- (3) Carrier Common Line charges shall not be reduced, as set forth in 12.4.3(A), unless Switched Access charges, as set forth in Section 4, are applied to the customer's Switched Access Services.
- (4) Terminating premium access, per minute charge(s) apply to:
 - all terminating access minutes of use;
 - less those terminating access minutes of use associated with Mobile Telephone Switching Offices (MTSOs);
 - all originating access minutes of use associated with FGA Access Services where the off-hook supervisory signaling is forwarded by the customer's equipment when the called party answers;
 - all originating access minutes of use associated with calls placed to Service Access Code numbers, less those originating access minutes of use associated with calls placed to 500, 700, 800 and 900 numbers for which the customer furnishes a report of either the number of minutes or a report of the percent of minutes that terminate to a subscriber or common line, rather than a dedicated access line. This report will be provided by the customer on a quarterly basis, indicating for each month thereof or quarter, the information as set forth preceding in order to calculate the common line charges.

FILEDAUG 01 2000
00-182**MISSOURI
Public Service Commission**

Issued: May 10, 2000

Effective: August 1, 2000

FACILITIES FOR INTRASTATE ACCESS

RECEIVED12. CARRIER COMMON LINE SERVICE (Cont'd)

MAY 10 2000

12.4 Rate Regulations (Cont'd)12.4.1 Description and Application of Rates (Cont'd)**MISSOURI
Public Service Commission**(E) Determination of Premium Charges (Cont'd)

(4) (Cont'd)

The customer will provide a report indicating separate common line information for 500, 700, 800 and 900 access minutes, at a statewide level and by jurisdiction.

The report will be based on the calendar year and will be due by the 15th day of the month preceding the quarter for which it is to be applied in order to become effective with the first full month of usage. Should the report be received after the 15th day of the month, the Telephone Company will make every effort to process the report as set forth above. When received by the Telephone Company as described herein, the quarterly report will be used for calculating common line charges on a current bill basis for the next three months usage.

Prorating or backbilling will not occur based on the report. Any under or over estimation should be reflected in the subsequent quarterly report.

If a billing dispute arises concerning the customer provided report, the Telephone Company will request the customer to provide the data used to develop the report. The Telephone Company will not request such data more than once a year. The customer shall supply the data within 30 days of the Telephone Company's request.

In the event the customer fails to provide a quarterly report, the Telephone Company will use the previously reported information to calculate the common line charges.

(5) The originating premium per minute charge(s) apply to:

- all originating access minutes of use;
- less those originating access minutes of use associated with FGA or BSA-A Access Services where the off-hook supervisory signaling is forwarded by the customer's equipment when the called party answers;
- less all originating access minutes of use associated with calls placed to Service Access Code numbers;
- less those originating access minutes of use associated with Mobile Telephone Switching Offices (MTSOs);
- plus all originating access minutes of use associated with calls placed to 500, 700, 800 and 900 numbers for which the customer furnishes a report of either the number of minutes or a report of the percent of minutes that terminate to a subscriber or common line, and for which a corresponding reduction in the number of terminating access minutes of use has been made as set forth in (4).

FILEDAUG 01 2000
05 - 182**MISSOURI
Public Service Commission**

Issued: May 10, 2000

Effective: August 1, 2000

FACILITIES FOR INTRASTATE ACCESS

RECEIVED

MAY 10 2000

12. CARRIER COMMON LINE SERVICE (Cont'd)12.4 Rate Regulations (Cont'd)12.4.2 Determination of Usage Subject to Carrier Common Line ChargesMISSOURI
Public Service Commission

Except as set forth herein, all Switched Access Service provided to the customer will be subject to Carrier Common Line charges.

(A) Determination of Jurisdiction

When the customer reports interstate and intrastate use of Switched Access Service, the associated Carrier Common Line charges for intrastate usage will be determined as in 4.3.2 and 4.5.2(J).

(B) Cases Involving Usage Recording By the Customer

Where FGC or BSA-C end office switching is provided without Telephone Company recording and the customer records minutes of use to determine Carrier Common Line charges (i.e., FGC operator and calls such as pay telephone sent-paid, operator-DDD, operator-person, collect, credit card, third number and/or other like calls), the customer shall furnish such minutes of use detail to the Telephone Company in a timely manner. If the customer does not furnish the data, the customer shall identify all Switched Access Services which could carry such calls in order for the Telephone Company to accumulate the minutes of use through the use of special Telephone Company measuring and recording equipment.

(C) Local Exchange Access and Enhanced Services Exemption

When access to the local exchange is required to provide a customer service (e.g., MTS/WATS-type, telex, Data, etc.) that uses a resold private line service, Switched Access Service Rates and Regulations, as in Section 4, will apply, except when such access to the local exchange is required for the provision of an enhanced service. Carrier Common Line charges, as in 12.5, apply in accordance with the resale rate regulations as in 12.4.3(D).

FILED

AUG 01 2000

00 - 182

MISSOURI
Public Service Commission

Issued: May 10, 2000

Effective: August 1, 2000

CANCELLED
October 19, 2009
Missouri Public
Service Commission
TN-2010-0092; YI-2010-0175

Kenneth Matzdorff
Chief Operating Officer
Kansas City, Missouri

FACILITIES FOR INTRASTATE ACCESS

RECEIVED12. CARRIER COMMON LINE SERVICE (Cont'd)

MAY 10 2000

12.4 Rate Regulations (Cont'd)MISSOURI
Public Service Commission12.4.3 Resold Services(A) Scope

There the customer is reselling MTS/MTS-type service(s) on which the Carrier Common Line and Switched Access charges have been assessed, the customer may, at the option of the customer, obtain FGA, FGB, FGD, BSA-A, BSA-B, BSA-D Switched Access Service under this tariff, as in Section 4, for originating and/or terminating access in the local exchange. Such access group arrangements, whether single lines or trunks or multiline hunt groups or trunk groups, will have Carrier Common Line charges, as in 12.5, applied in accordance with the resale rate regulations in (D) following. For purposes of administering this provision:

Resold intrastate terminating MTS/MTS-type service(s) shall include collect calls, third number calls and credit card calls where the reseller pays the underlying carrier's service charges, and shall not include intrastate minutes of use.

Resold intrastate originating MTS/MTS-type service(s) shall not include collect, third number, credit card or intrastate minutes of use.

(B) Customer Obligations Concerning the Resale of MTS/MTS-type Services

When the customer is reselling MTS/MTS-type service, as set forth in (A) preceding, the customer will be charged Carrier Common Line charges in accordance with the resale rate regulations, as set forth in (D) following, if the customer or the provider of the MTS/MTS-type service furnishes documentation of the MTS/MTS-type usage. Such documentation shall be supplied each month by the customer and shall identify the involved resold MTS/MTS-type services.

The monthly period used to determine the minutes of use for resold MTS/MTS-type service(s) shall be the most recent monthly period for which the customer has received a bill for such resold service(s). This information shall be delivered to the Telephone Company, at a location specified by the Telephone Company, no later than 15 days after the bill date shown on the resold MTS/MTS-type service bill. If the required information is not received by the Telephone Company, the previously reported information, as described preceding, will be used for the next two months. For any subsequent month, no allocation or credit will be made until the required documentation has been received by the Telephone Company.

FILEDAUG 01 2000
00-182MISSOURI
Public Service Commission

Issued: May 10, 2000

Effective: August 1, 2000

CANCELLED
October 19, 2009
Missouri Public
Service Commission
TN-2010-0092; YI-2010-0175

Kenneth Matzdorff
Chief Operating Officer
Kansas City, Missouri

FACILITIES FOR INTRASTATE ACCESS

RECEIVED

12. CARRIER COMMON LINE SERVICE (Cont'd)

MAY 10 2000

12.4 Rate Regulations (Cont'd)

MISSOURI
Public Service Commission

12.4.3 Resold Services (Cont'd)

(C) Resale Documentation Provided By the Customer

When the customer utilizes Switched Access Service, as in (B) preceding, the Telephone Company may request a certified copy of the customer's resold MTS/MTS-type usage billing from either the customer or the provider of the MTS/MTS-type service. Requests for billing will relate back no more than 12 months prior to the current billing period.

(D) Rate Regulations Concerning the Resale of MTS/MTS-type Services

When the customer is provided an access group or BSA to be used in conjunction with the resale of MTS/MTS-type services, as in (A) preceding, subject to the limitations, as in 12.2.2, and the billing entity receives the usage information required, as in (B) preceding, to calculate the adjustment of Carrier Common Line charges, the customer will be billed, as in (4), (5) or (6) following, depending upon, respectively, whether the usage is from nonequal access offices, equal access offices or a combination of the two.

(1) Apportionment and Adjustment of Resold Minutes of Use

When the customer is provided with more than one access group or BSA in a LATA in association with the resale of MTS/MTS-type services, the resold minutes of use will be apportioned as follows:

(a) Originating Services

The Telephone Company will apportion the resold originating MTS/MTS-type services and originating minutes of use for which the resale credit adjustment applies, among the access groups or BSAs. Such apportionment will be based on the relationship of the originating usage for each access group or BSA to the total originating usage for all access groups or BSAs in the LATA. For purposes of administering this provision:

Resold originating MTS/MTS-type services minutes shall be only those attributable to intrastate originating MTS/MTS-type minutes and shall not include collect, third number, credit card or interstate minutes of use.

The resale credit adjustment shall apply for resold originating MTS/MTS-type services and minutes of use, provided Carrier Common Line and Switched Access charges have been assessed on such services.

FILED

AUG 01 2000
00-182

MISSOURI
Public Service Commission

FACILITIES FOR INTRASTATE ACCESS

RECEIVED12. CARRIER COMMON LINE SERVICE (Cont'd)

MAY 10 2000

12.4 Rate Regulations (Cont'd)12.4.3 Resold Services (Cont'd)**MISSOURI
Public Service Commission**(D) Rate Regulations Concerning the Resale of MTS/MTS-type Services (Cont'd)(1) Apportionment and Adjustment of Resold Minutes of Use (Cont'd)(b) Terminating Services

The Telephone Company will apportion the resold terminating MTS/MTS-type services and terminating minutes of use for which the resale credit adjustment applies, among the access groups and BSAs. Such apportionment will be based on the relationship of the terminating usage for each access group or BSA to the total terminating usage for all access groups or BSAs in the LATA. For purposes of administering this provision:

Resold terminating MTS/MTS-type services minutes shall be only those attributable to intrastate terminating MTS/MTS-type minutes of use (i.e., collect, third number, and credit card) and shall not include interstate minutes of use or MTS/MTS-type minutes of use paid for by another party.

The resale credit adjustment shall apply for resold terminating MTS/MTS-type services and minutes of use, provided Carrier Common Line and Switched Access charges have been assessed on such services.

(2) Same State/Telephone Company/Exchange Limitation

In order for the rate regulations to apply, as in (4), (5) or (6) following, the access groups or BSAs and the resold MTS/MTS-type services must be provided in the same state (except when the same extended area service arrangement is provided in two different states by the same Telephone Company) in the same exchange, provided by the same Telephone Company and connected directly or indirectly. For those exchanges that encompass more than one state, the customer shall report the information by state within the exchange.

FILEDAUG 01 2000
00 - 182**MISSOURI
Public Service Commission**

Issued: May 10, 2000

Effective: August 1, 2000

FACILITIES FOR INTRASTATE ACCESS

RECEIVED12. CARRIER COMMON LINE SERVICE (Cont'd)

MAY 10 2000

12.4 Rate Regulations (Cont'd)12.4.3 Resold Services (Cont'd)

MISSOURI

(D) Rate Regulations Concerning the Resale of MTS/MTS-type Services (Cont'd)

Public Service Commission

(3) Direct and Indirect Connections

Each of the access group or BSA arrangements used by the customer in association with the resold MTS/MTS-type services must be connected either directly or indirectly to the customer designated premises at which the resold MTS/MTS-type services are terminated. Direct connections are those arrangements where the access groups and resold MTS/MTS-type services are terminated at the same customer designated premises.

Indirect originating connections are those arrangements where the access groups, BSAs and the resold originating MTS/MTS-type services are physically located at different customer designated premises in the same exchange. Such different customer designated premises are connected by facilities that permit a call to flow from access groups to resold MTS/MTS-type services.

Indirect terminating connections are those arrangements where the access groups, BSAs and resold terminating MTS/MTS-type services are physically located at different customer designated premises in the same exchange. Such different customer designated premises are connected by facilities that permit a call to flow from resold terminating MTS/MTS-type services to access groups or BSAs.

(4) Access Groups and BSAs - Nonequal Access Offices Only

The adjustments, as set forth here and in (5) and (6) following, will be computed separately for each access group.

When all the usage on an access group or BSA originates from and/or terminates to end offices that have not been converted to equal access, the premium charge per minute, as in 12.5, will apply. The access minutes which will be subject to Carrier Common Line charges will be the adjusted originating intrastate access minutes for such access groups or BSAs.

The adjusted originating access minutes will be the originating intrastate access minutes less the reported resold originating MTS/MTS-type service minutes of use, as in (1)(a) preceding, but not less than zero. The adjusted terminating access minutes will be the terminating intrastate access minutes less the reported resold terminating MTS/MTS-type service minutes of use, as in (1)(b) preceding, but not less than zero.

FILEDAUG 01 2000
00 - 182MISSOURI
Public Service Commission

Issued: May 10, 2000

Effective: August 1, 2000

FACILITIES FOR INTRASTATE ACCESS

RECEIVED12. CARRIER COMMON LINE SERVICE (Cont'd)

MAY 10 2000

12.4 Rate Regulations (Cont'd)12.4.3 Resold Services (Cont'd)MISSOURI
Public Service Commission(D) Rate Regulations Concerning the Resale of MTS/MTS-type Services (Cont'd)(5) Access Groups and BSAs - Equal Access Offices Only

When all the usage on an access group or BSA originates from and/or terminates to end offices that have been converted to equal access, the premium charge per minute, as in 12.5, will apply. The minutes billed Carrier Common Line charges will be the adjusted originating intrastate access minutes and the adjusted terminating intrastate access minutes for such access groups or BSAs.

The adjusted originating access minutes will be the originating intrastate access minutes less the reported resold originating MTS/MTS-type service minutes of use, as in (1)(a) preceding, but not less than zero. The adjusted terminating access minutes will be the terminating intrastate access minutes less the reported resold terminating MTS/MTS-type service minutes of use, as in (1)(b) preceding, but not less than zero.

(6) Access Groups and BSAs - Nonequal Access and Equal Access Offices

When an access group or BSA has usage that originates from and/or terminates to both end offices that have been converted to equal access and end offices that have not been converted, premium per minute charges, as in 12.5, will apply respectively. The minutes billed Carrier Common Line charges will be the adjusted originating intrastate access minutes plus the adjusted terminating intrastate access minutes for such access groups or BSAs.

The adjusted originating access minutes will be the originating intrastate access minutes less the reported resold originating MTS/MTS-type service minutes of use, as in (1)(a) preceding, but not less than zero. The adjusted terminating access minutes will be the terminating intrastate access minutes less the reported resold terminating MTS/MTS-type service minutes of use, as in (1)(b) preceding, but not less than zero.

FILEDAUG 01 2000
00 - 182MISSOURI
Public Service Commission

Issued: May 10, 2000

Effective: August 1, 2000

FACILITIES FOR INTRASTATE ACCESS

RECEIVED

12. CARRIER COMMON LINE SERVICE (Cont'd)

MAY 10 2000

12.4 Rate Regulations (Cont'd)

12.4.3 Resold Services (Cont'd)

MISSOURI
Public Service Commission

(D) Rate Regulations Concerning the Resale of MTS/MTS-type Services (Cont'd)

(7) When the Adjustment Will Be Applied to Customer Bills

The adjustment, as set forth in (4), (5) and (6) preceding, will be made to the involved customer account no later than either the next bill date, or the one subsequent to that, depending on when the usage report is obtained.

(8) Conversion of Billed Usage to Minutes

When the MTS/MTS-type usage is shown in hours, the number of hours shall be multiplied by 60 to develop the associated MTS/MTS-type minutes of use. If the MTS/MTS-type usage is shown in a unit that does not show hours or minutes, the customer shall provide a factor to convert the shown units to minutes.

(9) Mixed Interstate and Intrastate Usage

The adjustment, as set forth in (4), (5) and (6) preceding, will be made to the involved customer account after making the adjustments to the customer account, as set forth in 4.5.2(J).

FILED

AUG 01 2000
00-182

MISSOURI
Public Service Commission

Issued: May 10, 2000

Effective: August 1, 2000

CANCELLED
October 19, 2009
Missouri Public
Service Commission
TN-2010-0092; YI-2010-0175

Kenneth Matzdorff
Chief Operating Officer
Kansas City, Missouri

FACILITIES FOR INTRASTATE ACCESS

12. CARRIER COMMON LINE SERVICE (Cont'd)

12.5 Rates and Charges

Rates for Carrier Common Line Service are as follows:

<u>Intrastate InterLATA</u>		<u>Intrastate IntraLATA</u>	
<u>Premium Rate</u>		<u>Premium Rate</u>	
Per	Per	Per	Per
Originating	Terminating	Originating	Terminating
<u>Access Minute</u>	<u>Access Minute</u>	<u>Access Minute</u>	<u>Access Minute</u>
\$.02371769 (R)	\$.05482572 (R)	\$.02371769 (R)	\$.05482572 (R)

Issued: July 16, 2009

Effective: September 1, 2009

Chantel Mosby
Director, Tariffs and Compliance
Monroe, Louisiana

FACILITIES FOR INTRASTATE ACCESS

12. CARRIER COMMON LINE SERVICE (Cont'd)

12.5 Rates and Charges

Rates for Carrier Common Line Service are as follows:

<u>Intrastate InterLATA</u>		<u>Intrastate IntraLATA</u>	
<u>Premium Rate</u>		<u>Premium Rate</u>	
Per	Per	Per	Per
Originating	Terminating	Originating	Terminating
Access Minute	Access Minute	Access Minute	Access Minute
\$.02974331 (I)	\$.06170912 (I)	\$.02974331 (I)	\$.06170912 (I)

Issued: July 15, 2008

Effective: September 1, 2008

CANCELLED
September 1, 2009
Missouri Public
Service Commission
JI-2010-0029

Chantel Mosby
Director, Tariffs and Compliance
Monroe, Louisiana

FILED
Missouri Public
Service Commission

FACILITIES FOR INTRASTATE ACCESS

12. CARRIER COMMON LINE SERVICE (Cont'd)

12.5 Rates and Charges

Rates for Carrier Common Line Service are as follows:

<u>Intrastate InterLATA</u>		<u>Intrastate IntraLATA</u>	
<u>Premium Rate</u>		<u>Premium Rate</u>	
Per	Per	Per	Per
Originating	Terminating	Originating	Terminating
<u>Access Minute</u>	<u>Access Minute</u>	<u>Access Minute</u>	<u>Access Minute</u>
\$.02907258 (I)	\$.0603175 (I)	\$.02907258 (I)	\$.0603175 (I)

FACILITIES FOR INTRASTATE ACCESS

12. CARRIER COMMON LINE SERVICE (Cont'd)

12.5 Rates and Charges

Rates for Carrier Common Line Service are as follows:

<u>Intrastate InterLATA</u> <u>Premium Rate</u>		<u>Intrastate IntraLATA</u> <u>Premium Rate</u>	
Per	Per	Per	Per
Originating	Terminating	Originating	Terminating
Access Minute	Access Minute	Access Minute	Access Minute
\$.02853366 (R)	\$.0591994 (R)	\$.02853366 (R)	\$.0591994 (R)

Issued: July 14, 2006

Effective: September 1, 2006

Chantel Mosby
Manager, Tariffs and Compliance
Monroe, Louisiana

CANCELLED
Sept. 1, 2007
Missouri Public
Service Commission

Filed
Missouri Public
Service Commission

FACILITIES FOR INTRASTATE ACCESS

12. CARRIER COMMON LINE SERVICE (Cont'd)

12.5 Rates and Charges

Rates for Carrier Common Line Service are as follows:

<u>Intrastate InterLATA</u> <u>Premium Rate</u>		<u>Intrastate IntraLATA</u> <u>Premium Rate</u>		
Per Originating Access Minute	Per Terminating Access Minute	Per Originating Access Minute	Per Terminating Access Minute	
\$.02857875	\$.0592930	\$.02857875	\$.0592930	(R)

Issued: August 1, 2005

Effective: September 1, 2005

Chantel Mosby
Manager, Tariffs and Compliance
Monroe, Louisiana

Cancelled

September 1, 2006

Missouri Public
Service Commission

Filed

Missouri Public
Service Commission

FACILITIES FOR INTRASTATE ACCESS

12. CARRIER COMMON LINE SERVICE (Cont'd)

12.5 Rates and Charges

Rates for Carrier Common Line Service are as follows:

<u>Intrastate InterLATA</u> <u>Premium Rate</u>		<u>Intrastate IntraLATA</u> <u>Premium Rate</u>		
<u>Per</u> <u>Originating</u> <u>Access Minute</u>	<u>Per</u> <u>Terminating</u> <u>Access Minute</u>	<u>Per</u> <u>Originating</u> <u>Access Minute</u>	<u>Per</u> <u>Terminating</u> <u>Access Minute</u>	
\$.0291924	\$.0605665	\$.0291924	\$.0605665	(R)

CANCELLED
SEP 01 2005
by 3rd RS 313
Public Service Commission
MISSOURI

FACILITIES FOR INTRASTATE ACCESS

Missouri Public

12. CARRIER COMMON LINE SERVICE (Cont'd)

12.5 Rates and Charges

REC'D JUL 23 2003

Rates for Carrier Common Line Service are as follows:

Service Commission

<u>Intrastate InterLATA</u>		<u>Intrastate IntraLATA</u>	
<u>Premium Rate</u>		<u>Premium Rate</u>	
Per	Per	Per	Per
Originating	Terminating	Originating	Terminating
Access Minute	Access Minute	Access Minute	Access Minute
\$.0299664 (I)	\$.0621723 (R)	\$.0299664 (I)	\$.0621723 (R)

CANCELLED

SEP 01 2004
By *20RS313*
Public Service Commission
MISSOURI

FACILITIES FOR INTRASTATE ACCESS

RECEIVED

12. CARRIER COMMON LINE SERVICE (Cont'd)

MAY 10 2000

12.5 Rates and Charges

Rates for Carrier Common Line Service are as follows:

MISSOURI
Public Service Commission

<u>Intrastate InterLATA</u>		<u>Intrastate IntraLATA</u>	
<u>Premium Rate</u>		<u>Premium Rate</u>	
Per	Per	Per	Per
Originating	Terminating	Originating	Terminating
Access Minute	Access Minute	Access Minute	Access Minute
\$.02990131	\$.07141421	\$.02990131	\$.07141421

CANCELLED

SEP 06 2003
15705913
Public Service Commission
MISSOURI

FILED

AUG 01 2000
00 - 182
MISSOURI
Public Service Commission

FACILITIES FOR INTRASTATE ACCESS

13. COMPETITIVE EXCHANGES

13.1 BUSINESS EXCHANGES

The following exchanges are classified as competitive for business services:

EWING
LABELLE
LEWISTOWN
MACON

13.2. RESIDENTIAL EXCHANGES

The following exchanges are classified as competitive for residential services:

EVERTON (N)
EWING
LABELLE
LEWISTOWN
MACON
MT. VERNON (N)
SAVANNAH

Issued: February 1, 2006

Effective: March 3, 2006

Chantel Mosby
Manager, Tariffs and Compliance
Monroe, LA

FACILITIES FOR INTRASTATE ACCESS

CANCELLED

March 3, 2006

13. COMPETITIVE EXCHANGES

(N)

13.1 BUSINESS EXCHANGES

**MISSOURI PUBLIC
SERVICE COMMISSION**

(N)

The following exchanges are classified as competitive for business services:

EWING
LABELLE
LEWISTOWN
MACON

13.2. RESIDENTIAL EXCHANGES

The following exchanges are classified as competitive for residential services:

EWING
LABELLE
LEWISTOWN
MACON
SAVANNAH

(N)

FACILITIES FOR INTRASTATE ACCESS

13. (Reserved for Future Use)

RECEIVED

MAY 10 2000

**MISSOURI
Public Service Commission**

CANCELLED

OCT 09 2005

by *SPS314*
**Public Service Commission
MISSOURI**

FILED

AUG 01 2000

00 - 182

**MISSOURI
Public Service Commission**

Issued: May 10, 2000

Effective: August 1, 2000

Kenneth Matzdorff
Chief Operating Officer
Kansas City, Missouri

FACILITIES FOR INTRASTATE ACCESS

RECEIVED

SECTION 14 TABLE OF CONTENTS

14. EXCEPTIONS TO FIA OFFERINGS

MAY 10 2000

Sheet

14.1 <u>General</u>	MISSOURI Public Service Commission	316
14.2 (Reserved for Future Use)		317
14.3 (Reserved for Future Use)		317

FILED

AUG 01 2000
8 0 1 8 2

**MISSOURI
Public Service Commission**

Issued: May 10, 2000

Effective: August 1, 2000

CANCELLED
October 19, 2009
Missouri Public
Service Commission
TN-2010-0092; YI-2010-0175

Kenneth Matzdorff
Chief Operating Officer
Kansas City, Missouri

FACILITIES FOR INTRASTATE ACCESS

RECEIVED

14. EXCEPTIONS TO FIA OFFERINGS

MAY 10 2000

14.1 General

The FIA/Services offered under the provisions of this Public Service Commission subject to availability as set forth in 2.1.4 preceding. In addition, the following exceptions apply:

MISSOURI

Public Service Commission

(Reserved for Future Use)

FILED

AUG 01 2000

00-182

MISSOURI

Public Service Commission

Issued: May 10, 2000

Effective: August 1, 2000

CANCELLED
October 19, 2009
Missouri Public
Service Commission
TN-2010-0092; YI-2010-0175

Kenneth Matzdorff
Chief Operating Officer
Kansas City, Missouri

FACILITIES FOR INTRASTATE ACCESS

14. EXCEPTIONS TO FIA OFFERINGS (Cont'd)

14.2 The following items are offered only to existing ICs and/or end users at their existing points of presence and/or premises, respectively, associated with existing FIA arrangements:

(Reserved for Future Use)

14.3 The following items are offered only to existing ICs and/or end users at their existing points of presence and/or premises, respectively, associated with existing FIA arrangements and to fill out existing capacity:

(Reserved for Future Use)

RECEIVED

MAY 10 2000

MISSOURI
Public Service Commission

FILED

AUG 01 2000
00 - 182

MISSOURI
Public Service Commission

Issued: May 10, 2000

Effective: August 1, 2000

CANCELLED
October 19, 2009
Missouri Public
Service Commission
TN-2010-0092; YI-2010-0175

Kenneth Matzdorff
Chief Operating Officer
Kansas City, Missouri

FACILITIES FOR INTRASTATE ACCESS

15. (Reserved for Future Use)

RECEIVED

MAY 10 2000

**MISSOURI
Public Service Commission**

FILED

AUG 01 2000
00 - 182

**MISSOURI
Public Service Commission**

Issued: May 10, 2000

Effective: August 1, 2000

CANCELLED
October 19, 2009
Missouri Public
Service Commission
TN-2010-0092; YI-2010-0175

Kenneth Matzdorff
Chief Operating Officer
Kansas City, Missouri

FACILITIES FOR INTRASTATE ACCESS

RECEIVED

MAY 10 2000

TABLE OF CONTENTS

MISSOURI

Public Service Commission

16. ADVANCED COMMUNICATIONS NETWORKS sheet

16.1 General 320

16.2 (Reserved for Future Use) 320

16.3 Frame Relay Service 321

(A) Service Description 321

(B) Service Provisioning 321

(C) Obligations of the Telephone Company 323

(D) Obligations of the Customer 323

(E) Rate Regulations 323

(F) Rates and Charges 329

FILED

AUG 01 2000
00-182

MISSOURI
Public Service Commission

RECEIVED

FACILITIES FOR INTRASTATE ACCESS

MAY 10 2000

16. ADVANCED COMMUNICATIONS NETWORKS (Cont'd)

16.1 General

This section contains the rules and regulations pertaining to the provision of Frame Relay Service. The regulations and rates specified herein are in addition to the applicable regulations and rates specified in other sections of this tariff.

MISSOURI
Public Service Commission

16.2 (Reserved for Future Use)

FILED

AUG 01 2000
00 - 182

MISSOURI
Public Service Commission

Issued: May 10, 2000

Effective: August 1, 2000

CANCELLED
October 19, 2009
Missouri Public
Service Commission
TN-2010-0092; YI-2010-0175

Kenneth Matzdorff
Chief Operating Officer
Kansas City, Missouri

FACILITIES FOR INTRASTATE ACCESS

RECEIVED16. ADVANCED COMMUNICATIONS NETWORKS (Cont'd)

MAY 10 2000

16.3 Frame Relay Service(A) Service Description

Frame Relay Service (FRS) is a "fast packet" network service for the transmission of data at speeds of 56/64* Kbps, 128 Kbps, 256 Kbps, 384 Kbps, DS1, or DS3 using Permanent Virtual Circuits (PVCs).

PVCs are logical circuits that define a specific path for data sent by the customer to another location. These circuits are virtual because they are established in software tables and do not tie up capacity when not in use. This also allows multiple paths (PVCs) to be defined on any given port, thereby providing a single access line the capability to transmit data to multiple destinations.

In operation of Frame Relay Service, customer premises equipment, such as routers, encapsulate arriving data into variable length frames. These frames contain information identifying which PVC in the network should be used to forward the frame to the proper destination. The customer premises equipment then sends the frame into the Frame Relay network. The Frame Relay switch reads identifying information and routes the frame to the proper destination based on a pre-established PVC path.

The statistical multiplexing Frame Relay switches are able to provide shared network resources to end users of this service.

Frame Relay Service conforms to ITU-T (Telecommunication Standardization Bureau of the International Telecommunication Union formerly Consultative Committee for International Telegraph and Telephone ([CCITT]) and American National Standards Institute (ANSI) publications T1.602, T1.606, T1.617 and T1.618.

The Committed Information Rate (CIR) and the Excess Burst Size [B(e)] are traffic management parameters that allow the customer to fine tune implementation of Frame Relay Service.

Clear Channel Capability will be provided upon request and where deemed applicable by the Company. Special construction charges may apply.

The Optional Payment Plan (OPP) arrangements are available as set forth under 16.3.(E)(4).

(B) Service Provisioning

Frame Relay is a transport service that facilitates the exchange of variable length information units (frames) between end user connections by way of assigned virtual connections. Each frame is passed to the Frame Relay network with an address that specifies the virtual connection.

Variable frame length capability is useful in communications between asynchronous Local Area Networks (LANs) and for transport of synchronous data traffic. Frame Relay is capable of handling the requirements of bursty data sources because of the ability of the service to allocate additional bandwidth when not in use by other sources.

Frame Relay is provided to the customer in the form of the Frame Relay User-to-Network Interface (UNI) Port with Access Line, or Frame Relay UNI Port Only, Frame Relay Network-to-Network (NNI) Port Only, Frame Relay Public NNI based on Committed Information Rate (CIR), and CIR-based Permanent Virtual Circuits (PVCs). The Frame Relay Access Line forms the component which provides the customer access to the customer's serving wire center and interoffice transport from the customer's serving wire center to the Frame Relay Switch. The Frame Relay Access line is provided for use only with Frame Relay Service and where pre-established by the Telephone Company. DS3 Frame Relay Service is not offered bundled with the Frame Relay Access Line. DS3 Frame Relay Service is available on a UNI or NNI port only basis and the DS3 access line is obtained from Section 5. The Frame Relay UNI or NNI Port Only offerings are provided for digital special access line connections to the network supporting Frame Relay Service. Digital special access lines are available from Section 5.

* Upon request and where available.

Issued: May 10, 2000

Effective: August 1, 2000

FILEDAUG 01 2000
00 - 182**MISSOURI
Public Service Commission**

CANCELLED
October 19, 2009
Missouri Public
Service Commission
TN-2010-0092; YI-2010-0175

Kenneth Matzdorff
Chief Operating Officer
Kansas City, Missouri

FACILITIES FOR INTRASTATE ACCESS

RECEIVED16. ADVANCED COMMUNICATIONS NETWORKS (Cont'd)

MAY 10 2000

16.3 Frame Relay Service (Cont'd)MISSOURI
Public Service Commission(B) Service Provisioning (Cont'd)

PVCs are provisioned on either 56/64 Kbps, 128 Kbps, 256 Kbps, 384 Kbps, DS1 or DS3 ports, depending upon the customer's request. The actual throughput of aggregated PVC bandwidths in use at the same time on the same port cannot exceed the port speed. Since multiple PVCs may be defined on one physical port, it is possible for the cumulative CIRs to exceed the physical bandwidth of that port. This is referred to as over-subscription and when this occurs, there can be no guarantee that the CIR defined for that port and PVC will be available at any point in time.

No PVC can have a CIR greater than the lower of the two port speeds connected by the PVC segment.

A PVC must be associated with at least one Frame Relay Port. A Frame Relay Port can be associated with multiple PVCs.

A customer subscribing to a FRS port or port with access line will be referred to as the Controller of the Frame Relay Port. A separate entity may subscribe, with written authorization from the Controller, to a PVC which allows communication between entities. A disconnect of a PVC does not result in the disconnect of the underlying access line and port. Only the Controller may order the disconnect of the Frame Relay Access Service. Both customers must have a Frame Relay Service. The Controller of each Frame Relay Access Service must have written permission from the Controller(s) of each of the Frame Relay Services to which a PVC is requested.

The Frame Relay Port with PVC-CIR capacity may be ordered and billed separately from an associated frame relay port and PVC and can have different customers as Controllers.

CIR is the maximum information rate at which the customer's traffic will be admitted to the Frame Relay Network without being designated eligible for discard. The Committed Information Rate (CIR) and Excess Burst Size [B(e)] are traffic management parameters that allow the customer to fine tune implementation of Frame Relay Service.

The Telephone Company does not undertake to originate data, but offers the use of its service components, where available, to customers for the purpose of transporting customer-originated data.

Frame Relay Service is available where facilities and conditions permit.

Occasionally, in order to perform software updates and other maintenance, it may be necessary to take the Frame Relay Switch out of service, during the predetermined maintenance window 12:01am to 06:00am. In these cases, all attempts will be made to notify the customer in advance as to the time and duration of these outages. The Telephone Company reserves the right to temporarily interrupt Frame Relay Service at other times in emergency situations.

FILEDAUG 01 2000
00 - 182MISSOURI
Public Service Commission

Issued: May 10, 2000

Effective: August 1, 2000

FACILITIES FOR INTRASTATE ACCESS

RECEIVED

MAY 10 2000

16. ADVANCED COMMUNICATIONS NETWORKS (Cont'd)

16.3 Frame Relay Service (Cont'd)

MISSOURI
Public Service Commission

(C) Obligations of the Telephone Company

In addition to the general conditions described in Section 2, when a customer requests a path which is related to other Local Exchange Carriers, Interexchange Carriers or other Frame Relay networks, the Telephone Company will provide assistance in establishing the associated PVC.

The Telephone Company has the service responsibility up to and including the network interface.

(D) Obligations of the Customer

In addition to the general conditions described in Section 2:

- The customer's Frame Relay terminal equipment has the responsibility for retransmitting frames which are discarded due to errors or network congestion.
- The customer, upon request, shall furnish such information as may be required to permit the Telephone Company to design and maintain the Frame Relay Service it offers and to assure that the service arrangement is in compliance with the regulations contained herein.
- It shall be the responsibility of the customer to ensure the continuing compatibility of the customer-provided equipment (CPE) that is used in conjunction with the Frame Relay Service. The CPE shall be in compliance with FCC rules and regulations.
- The customer shall be responsible for obtaining permission for the Telephone Company's agents or employees to enter the premises of the customer or its users at any reasonable hour for the purpose of installing, inspecting, repairing, or, upon termination of the service, removing the service components of the Telephone Company.
- At service subscription, the customer should specify the CIR and B(e) of each PVC ordered. CIR is the maximum information rate at which the customer's traffic will be admitted to the Frame Relay network without being designated eligible for discard. A default of fifty (50) percent of the smallest port size will be assigned as the CIR should the information not be provided. One hundred percent CIR will be allowed when conditions and infrastructure permit. The excess burst size will be defaulted to zero.
- Error correction is the responsibility of the customer's terminal equipment and/or applications. If the FRS network experiences congestion or failures, customer data may be discarded. In addition, frames that are received in excess of the B(e), with bad addresses, or other errors, will be discarded on ingress to the network.

(E) Rate Regulations

(1) Minimum Period

The minimum period for Frame Relay Service is one month, except when provided under an Optional Payment Plan (OPP) arrangement. The regulations applicable to Frame Relay Service provided under an OPP arrangement are specified under 16.3(E)(4). CIR based PVCs and Public NNI access are not offered under an OPP. When PVCs are added to existing Frame Relay Service, the minimum period for the added PVCs is one month.

FILED

Issued: May 10, 2000

Effective: August 1, 2000

AUG 01 2000
00-182

MISSOURI
Public Service Commission

Kenneth Matzdorff
Chief Operating Officer
Kansas City, Missouri

FACILITIES FOR INTRASTATE ACCESS

RECEIVED16. ADVANCED COMMUNICATIONS NETWORKS (Cont'd)

MAY 10 2000

16.3 Frame Relay Service (Cont'd)MISSOURI
Public Service Commission(E) Rate Regulations (Cont'd)

(2) Rate Elements

(a) Frame Relay UNI Port and Access Line

A nonrecurring charge and a monthly rate, based on the speed of the port connection (i.e., 56/64 Kbps, 128 Kbps, 256 Kbps, 384 Kbps or DS1), apply per port for each Frame Relay Access Line or digital private line connection to the network supporting Frame Relay Service. Each port can accommodate multiple PVCs.

(b) Frame Relay UNI Port Only

The User-to-Network Interface (UNI) port provides for an end user to carrier connection. A nonrecurring charge and monthly rate, based on the speed of the port connection, apply per port for each Frame Relay Access Line or digital private line connection to the network supporting Frame Relay Service. The digital private line connection can be provided via a special access line and special transport to the nearest Telephone Company Frame Relay serving wire center, if applicable, offered in Section 5 of this tariff.

(c) Frame Relay Private NNI Port Only

The Private Network-to-Network Interface (NNI) port provides for connecting two networks together for Frame Relay Service, which is dedicated to one customer. A nonrecurring charge and monthly rate, based on the speed of the port connection, apply per port for each digital private line connection to the network supporting Frame Relay Service. The digital private line connection can be provided via a special access line and special transport, if applicable, offered in Section 5 of this tariff.

(d) Frame Relay CIR-PVC

A monthly rate applies for each PVC based on the CIR requested by the customer. If no CIR is indicated, the CIR will be set at the default of 50% of the associated Frame Relay Port. One hundred percent CIR will be allowed when conditions and infrastructure permit.

Customers may purchase Express PVC-1 or Express PVC-2, to prioritize PVCs at a higher rate than CIR-PVCs. Express PVC will help to ensure maximum performance and satisfaction for applications such as voice over Frame Relay. The above conditions apply to Express PVC.

(e) Frame Relay Public NNI Access

The public Network-to-Network (NNI) access connections are shared among several customers whose data traffic traverses the link. The monthly rate is applied based on the CIR requested by the customer. Public NNI access will be provisioned where pre-established.

(f) CIR-PVC Subsequent Order Charge

When a customer orders additional PVCs or B(e) or changes PVC or B(e) assignments on a Frame Relay port after the initial port installation, the CIR-PVC Subsequent Order Charge will apply per order.

(g) Excess Burst Size [B(e)]

For port size of 256 Kbps or higher, a burst size monthly recurring charge may be applicable. B(e) is uncommitted data.

FILED

Issued: May 10, 2000

Effective: August 1, 2000

CANCELLED
October 19, 2009
Missouri Public
Service Commission
TN-2010-0092; YI-2010-0175

Kenneth Matzdorff
Chief Operating Officer
Kansas City, Missouri

AUG 01 2000 8 2
MISSOURI
Public Service Commission

FACILITIES FOR INTRASTATE ACCESS

RECEIVED

16. ADVANCED COMMUNICATIONS NETWORKS (Cont'd)

MAY 10 2000

16.3 Frame Relay Service (Cont'd)

MISSOURI
Public Service Commission

(E) Rate Regulations (Cont'd)

(3) Rate Application

A customer may access Frame Relay Service via a Frame Relay Access Line or via Telephone Company provided digital access facilities offered under Section 5. If a customer utilizes a special access line to access FRS, the associated regulations, rates and charges for such facilities shall apply in addition to the rates and charges associated with the FRS rate elements.

A customer utilizing special access facilities to access FRS would incur the monthly rate and nonrecurring charge associated with the Frame Relay UNI or NNI Port Only charge set forth under 16.3(F)(2) or 16.3(F)(3) respectively for standard arrangements. The UNI Port provides for a user to frame relay switch connection; the NNI Port provides for a frame relay switch to frame relay switch connection.

The Frame Relay Access Line and its associated PVC segment(s) may be ordered and billed separately from an associated frame relay port and PVC and can have different Controllers, as discussed under 16.3(B). A request by one customer to discontinue a PVC does not result in the disconnection of the Frame Relay Access Line and Port. Only the Controller of a Frame Relay Access Line may authorize a disconnect of that line.

Administrative changes to existing service will be made without charge(s) to the customer. Administrative changes are as follows:

- b Change of customer name, i.e., the customer or record does not change but rather the name of record changes its name, e.g., XYZ Company to XYZ Communications,
- b Change of customer premises address when the change of address is not a result of a physical relocation of facilities,
- b Change in billing data (name, address, or contact name or telephone number),
- b Change of customer contact name or telephone number, and
- b Change of customer service element identification.

(4) Optional Payment Plan (OPP)

(a) General

- (1) The terms and conditions specified herein are applicable to Frame Relay Service and are in addition to other regulations as specified in this tariff.
- (2) The Frame Relay UNI Port with Access Line, the Frame Relay UNI or NNI Port Only rate elements are available under an OPP. CIR-PVC and Public NNI rate elements are not offered under an OPP. Digital special access lines and additional features are available at their tariffed rates and regulations.
- (3) Frame Relay OPP rates will not be greater than standard month-to-month Frame Relay rates, for the same rate elements.

FILED

AUG 01 2000

00 - 182

MISSOURI
Public Service Commission

Issued: May 10, 2000

Effective: August 1, 2000

CANCELLED
October 19, 2009
Missouri Public
Service Commission
TN-2010-0092; YI-2010-0175

Kenneth Matzdorff
Chief Operating Officer
Kansas City, Missouri

FACILITIES FOR INTRASTATE ACCESS

RECEIVED

16. ADVANCED COMMUNICATIONS NETWORKS (Cont'd)

MAY 10 2000

16.3 Frame Relay Service (Cont'd)

**MISSOURI
Public Service Commission**

(E) Rate Regulations (Cont'd)

(4) Optional Payment Plan (OPP) (Cont'd)

(a) General

- (4) Three year and five year OPP rates will be equal to or less than the one year OPP rates. Decreases to the one year OPP rates will flow through to the three year and five year OPP rates.
- (5) Payment periods of one year, three years, and five years are available to all customers at the applicable rates set forth in 16.3(F)(1-3) regardless of when they subscribe to an OPP arrangement. Rate elements must be ordered under the same OPP period.
- (6) The customer must designate on the order the payment period for the OPP.
- (7) Inside moves, provided in accordance with Section 5.6.4(A), will not incur termination liability charges.
- (8) Outside moves, provided in accordance with Section 5.6.4(B), will allow the customer to retain the same OPP payment period. Any other move will be treated as a disconnect of the service and termination liability charges will apply.

FILED

AUG 01 2000

00-182
**MISSOURI
Public Service Commission**

Issued: May 10, 2000

Effective: August 1, 2000

CANCELLED
October 19, 2009
Missouri Public
Service Commission
TN-2010-0092; YI-2010-0175

Kenneth Matzdorff
Chief Operating Officer
Kansas City, Missouri

FACILITIES FOR INTRASTATE ACCESS

RECEIVED16. ADVANCED COMMUNICATIONS NETWORKS (Cont'd)

MAY 10 2000

16.3 Frame Relay Service (Cont'd)MISSOURI
Public Service Commission(E) Rate Regulations (Cont'd)

(4) Optional Payment Plan (OPP) (Cont'd)

(b) Changes in Length of OPP Period

Prior to the completion of the selected OPP period, the customer may elect to convert to a new OPP period of the same or different length, subject to the following conditions:

- No credit toward the new payment period will be given for payments made under the original OPP arrangement.
- Nonrecurring charges will not be reapplied for existing service(s).
- If the new OPP period is shorter in length than the time remaining under the existing OPP, the change to the new OPP period constitutes a discontinuance of the existing OPP service and termination liability charges apply.

(c) Renewal Options

- (1) At the expiration of an OPP period, the Telephone Company will automatically renew the service at the same OPP period unless the customer chooses to convert to a different OPP period, convert to month-to-month rates or discontinue service.
- (2) Conversion to a different OPP period will require the customer to submit a change order. Conversion of existing OPP service to a different OPP period will be allowed without application of any nonrecurring or ordering charges.
- (3) Conversion to month-to-month rates will be treated as a disconnect of service and establishment of new service. However, if no other changes are ordered, no charge will apply.

(d) Notification of Discontinuance

An order for discontinuance of an OPP arrangement must be submitted in writing and received by the Telephone Company at least thirty (30) days prior to actual disconnect of service. Monthly charges will apply for a period of thirty (30) days from the date the Telephone Company receives disconnect notification or until the requested disconnect date, whichever period is longer.

(e) Upgrade to Higher Speed Service

Customers may elect to upgrade service(s) to a higher speed during an OPP period, subject to the following conditions:

- The order to discontinue a service at an existing speed or capacity and the order for the upgraded service are received by the Company at the same time.
- The fixed period plan for the upgraded service(s) meets or exceeds the remaining length of the existing fixed-period plan.
- The total monthly rate of the new agreement is equal to or greater than the total monthly rate of the existing agreement period.

FILED

Issued: May 10, 2000

Effective: August 1, 2000

CANCELLED
October 19, 2009
Missouri Public
Service Commission

TN-2010-0092; YI-2010-0175

Kenneth Matzdorff
Chief Operating Officer
Kansas City, Missouri

AUG 01 2000
00-182
MISSOURI
Public Service Commission

FACILITIES FOR INTRASTATE ACCESS

RECEIVED16. ADVANCED COMMUNICATIONS NETWORKS (Cont'd)

MAY 10 2000

16.3 Frame Relay Service (Cont'd)MISSOURI
Public Service Commission(E) Rate Regulations (Cont'd)

(4) Optional Payment Plan (OPP) (Cont'd)

(e) Upgrade to Higher Speed Service (Cont'd)

- The monthly rates for the upgraded services and/or service elements will be those in effect at the time of the service upgrade.
- Termination liability charges will not apply as long as the upgraded service remains connected at the same point of termination(s) or meets the requirements set forth in Section 5.6.4(B)(2), and is provided by the Telephone Company.
- Nonrecurring charges will not apply to the upgraded Port or Port and Access Line.
- Nonrecurring charges will apply for all other services.

(f) Termination Liability

When an OPP arrangement is discontinued prior to the end of the period, termination liability charges, as set forth below, will apply based on the remainder of the OPP period in effect at the time of disconnect.

Termination charges for Frame Relay Service (Port Only or Port and Access) will also apply if the minimal amount defined in the contract is not retained. Charges are set forth below with the penalty assessed for each service that falls below the minimum number.

One Year OPP - 50% of any remaining portion of the first year's recurring charges for the in service quantity.

Three Year OPP - 50% of any remaining portion of the first year's recurring charges. In addition, for any remaining portion of the second and third years, the customer will be liable for 10% of the total monthly recurring charges in that time period for the in service quantity.

Five Year OPP - 50% of any remaining portion of the first year's recurring charges. In addition, for any remaining portion of the second through fifth years, the customer will be liable for 20% of the total monthly recurring charges in that time period for the in service quantity.

(g) Termination Without Liability

During an OPP period, should the currently effective rate for a customer's service increase, the customer may, at his/her option, terminate the OPP arrangement without penalty or liability.

(h) Credit of Termination Liability

Credit of termination liability charges for Frame Relay Services may be applicable in the case of re-establishment of similar Frame Relay Service of equal to or higher speeds within six months of termination for the same length of the OPP. The amount of credit will be one-sixth of the penalty times the number of months service is re-established until the sixth month.

FILED

Issued: May 10, 2000

Effective: August 1, 2000

AUG 01 2000
00-182MISSOURI
Public Service CommissionKenneth Matzdorff
Chief Operating Officer
Kansas City, Missouri

FACILITIES FOR INTRASTATE ACCESS

RECEIVED16. ADVANCED COMMUNICATIONS NETWORKS (Cont'd)

MAY 10 2000

16.3 Frame Relay Service (Cont'd)(F) Rates and ChargesMISSOURI
Public Service Commission

	<u>Nonrecurring Charges</u>	<u>Monthly Rate</u>	<u>USOC</u>	<u>IOSC</u>
(1) <u>Frame Relay UNI Port and Access</u> <u>Line, Each</u>				
56/64** Kbps				14285 (NRC)
Month to Month	\$295.00	\$110.00	FP8	14269
1 Year OPP	295.00	105.00	FP8	14274
3 Year OPP	295.00	95.00	FP8	14279
5 Year OPP	295.00	85.00	FP8	14280
128 Kbps				14203 (NRC)
Month to Month	\$395.00	\$200.00	FP8	14221
1 Year OPP	395.00	180.00	FP8	14226
3 Year OPP	395.00	165.00	FP8	14231
5 Year OPP	395.00	160.00	FP8	14232
256 Kbps				14203 (NRC)
Month to Month	\$395.00	\$280.00	FP8	14237
1 Year OPP	395.00	250.00	FP8	14242
3 Year OPP	395.00	235.00	FP8	14247
5 Year OPP	395.00	220.00	FP8	14248
384 Kbps				14203 (NRC)
Month to Month	\$395.00	\$365.00	FP8	14253
1 Year OPP	395.00	345.00	FP8	14258
3 Year OPP	395.00	335.00	FP8	14263
5 Year OPP	395.00	320.00	FP8	14264
DS1 (1.536 Mbps)				14220 (NRC)
Month to Month	\$395.00	\$530.00	FP8	14204
1 Year OPP	395.00	510.00	FP8	14209
3 Year OPP	395.00	490.00	FP8	14214
5 Year OPP	395.00	470.00	FP8	14215
(2) <u>Frame Relay UNI Port Only</u> <u>Each *</u>				
56/64** Kbps				14302 (NRC)
Month to Month	\$ 80.00	\$ 45.00	FP9	14145
1 Year OPP	80.00	43.00	FP9	14146
3 Year OPP	80.00	41.00	FP9	14147
5 Year Opp	80.00	38.00	FP9	14148

FILEDAUG 01 2000
00 - 182MISSOURI
Public Service Commission* Refer to Section 5, Special Access, for appropriate SAL and Transport Rate.
** Where conditions allow.

Issued: May 10, 2000

Effective: August 1, 2000

CANCELLED
October 19, 2009
Missouri Public
Service Commission
TN-2010-0092; YI-2010-0175Kenneth Matzdorff
Chief Operating Officer
Kansas City, Missouri

FACILITIES FOR INTRASTATE ACCESS

RECEIVED16. ADVANCED COMMUNICATIONS NETWORKS (Cont'd)

MAY 10 2000

16.3 Frame Relay Service (Cont'd)(F) Rates and Charges (Cont'd)MISSOURI
Public Service Commission

	<u>Nonrecurring Charges</u>	<u>Monthly Rate</u>	<u>USOC</u>	<u>IOSC</u>
(2) <u>Frame Relay UNI Port Only, Each *</u> (Cont'd)				
128 Kbps				14299 (NRC)
Month to Month	\$ 150.00	\$ 80.00	FP9	14149
1 Year OPP	150.00	75.00	FP9	14150
3 Year OPP	150.00	70.00	FP9	14151
5 Year OPP	150.00	68.00	FP9	14152
256 Kbps				14299 (NRC)
Month to Month	\$ 150.00	\$ 115.00	FP9	14153
1 Year OPP	150.00	110.00	FP9	14154
3 Year OPP	150.00	105.00	FP9	14155
5 Year OPP	150.00	100.00	FP9	14156
384 Kbps				14299 (NRC)
Month to Month	\$ 150.00	\$ 160.00	FP9	14157
1 Year OPP	150.00	150.00	FP9	14158
3 Year OPP	150.00	140.00	FP9	14159
5 Year OPP	150.00	130.00	FP9	14160
DS1 (1.536 Mbps)				14301 (NRC)
Month to Month	\$ 395.00	\$ 300.00	FP9	14161
1 Year OPP	395.00	285.00	FP9	14162
3 Year OPP	395.00	265.00	FP9	14163
5 Year OPP	395.00	245.00	FP9	14164
DS3 (44 Mbps)				15464 (NRC)
Month to Month	\$ 395.00	\$1180.00	FP9	15460
1 Year OPP	395.00	1140.00	FP9	15461
3 Year OPP	395.00	1090.00	FP9	15462
5 Year OPP	395.00	1050.00	FP9	15463
(3) <u>Frame Relay NNI Port Only, Each *</u>				
56/64 ** Kbps				54285 (NRC)
Month to Month	\$ 55.00	\$ 30.00	NN7	54286
1 Year OPP	55.00	27.00	NN7	54287
3 Year OPP	55.00	23.00	NN7	54288
5 Year Opp	55.00	20.00	NN7	54289

FILED

AUG 01 2000

00 - 182

MISSOURI
Public Service Commission

* Refer to Section 5, Special Access, for appropriate SAL and Transport Rate.
 ** Where conditions allow.

Issued: May 10, 2000

Effective: August 1, 2000

CANCELLED
 October 19, 2009
 Missouri Public
 Service Commission
 TN-2010-0092; YI-2010-0175

Kenneth Matzdorff
 Chief Operating Officer
 Kansas City, Missouri

FACILITIES FOR INTRASTATE ACCESS

RECEIVED16. ADVANCED COMMUNICATIONS NETWORKS (Cont'd)16.3 Frame Relay Service (Cont'd)(F) Rates and Charges (Cont'd)

MAY 10 2000

MISSOURI
Public Service Commission

	<u>Nonrecurring Charges</u>	<u>Monthly Rate</u>	<u>USOC</u>	<u>IOSC</u>
(3) <u>Frame Relay NNI Port Only, Each * (Cont'd)</u>				
128 Kbps				54290 (NRC)
Month to Month	\$ 95.00	\$ 45.00	NN7	54291
1 Year OPP	95.00	40.00	NN7	54292
3 Year OPP	95.00	35.00	NN7	54293
5 Year OPP	95.00	30.00	NN7	54294
256 Kbps				54290 (NRC)
Month to Month	\$ 95.00	\$ 65.00	NN7	54295
1 Year OPP	95.00	60.00	NN7	54296
3 Year OPP	95.00	55.00	NN7	54297
5 Year OPP	95.00	50.00	NN7	54298
384 Kbps				54290 (NRC)
Month to Month	\$ 95.00	\$ 78.00	NN7	54299
1 Year OPP	95.00	75.00	NN7	54300
3 Year OPP	95.00	72.00	NN7	54301
5 Year OPP	95.00	69.00	NN7	54302
DS1 (1.536 Mbps)				54303 (NRC)
Month to Month	\$295.00	\$180.00	NN7	54304
1 Year OPP	295.00	170.00	NN7	54305
3 Year OPP	295.00	160.00	NN7	54306
5 Year OPP	295.00	150.00	NN7	54307
DS3 (44 Mbps)				54308 (NRC)
Month to Month	\$595.00	\$800.00	NN7	54309
1 Year OPP	595.00	750.00	NN7	54310
3 Year OPP	595.00	725.00	NN7	54211
5 Year OPP	595.00	700.00	NN7	54312
(4) <u>250 Kbps - Burst (Be)</u>	--	\$ 2.00	BTZAZ	54313
(5) <u>1 Mbps - Burst (Be)</u>	--	\$ 5.00	BTZAB	54314
(6) <u>Subsequent Ordering Charge (CIR, Be)</u>	\$ 20.00	--	NRBFT	54315

FILEDAUG 01 2000
00 - 182MISSOURI
Public Service Commission

* Refer to Section 5, Special Access, for appropriate SAL and Transport Rate.

Issued: May 10, 2000

Effective: August 1, 2000

CANCELLED
October 19, 2009
Missouri Public
Service Commission
TN-2010-0092; YI-2010-0175Kenneth Matzdorff
Chief Operating Officer
Kansas City, Missouri

FACILITIES FOR INTRASTATE ACCESS

RECEIVED16. ADVANCED COMMUNICATIONS NETWORKS (Cont'd)

MAY 10 2000

16.3 Frame Relay Service (Cont'd)(F) Rates and Charges (Cont'd)MISSOURI
Public Service Commission

	<u>Nonrecurring</u>	<u>Monthly</u>	<u>USOC</u>	<u>IOSC</u>
	<u>Charges</u>	<u>Rate</u>		
(7) <u>Frame Relay Permanent Virtual Circuit CIR Capacity, Each</u> <u>Based on CIR Requested</u>				
1 - 32 Kbps CIR	--	\$ 8.00	CORUK	54200
Express PVC-1	--	10.00	R01UK	54221
Express PVC-2	--	8.80	R02UK	54242
33 - 64 Kbps CIR	--	15.00	CORUL	54201
Express PVC-1	--	18.75	R01UL	54222
Express PVC-2	--	16.50	R02UL	54243
65 - 96 Kbps CIR	--	22.00	CORUM	54202
Express PVC-1	--	27.50	R01UM	54223
Express PVC-2	--	24.20	R02UM	54244
97 - 128 Kbps CIR	--	27.00	CORUN	54203
Express PVC-1	--	33.75	R01UN	54224
Express PVC-2	--	29.70	R02UN	54245
129 - 192 Kbps CIR	--	36.00	CORUO	54204
Express PVC-1	--	45.00	R01UO	54225
Express PVC-2	--	39.60	R02UO	54246
193 - 256 Kbps CIR	--	42.00	CORUP	54205
Express PVC-1	--	52.50	R01UP	54226
Express PVC-2	--	46.20	R02UP	54247
257 - 320 Kbps CIR	--	48.00	CORUQ	54206
Express PVC-1	--	60.00	R01UQ	54227
Express PVC-2	--	52.80	R02UQ	54248
321 - 384 Kbps CIR	--	54.00	CORUR	54207
Express PVC-1	--	67.50	R01UR	54228
Express PVC-2	--	59.40	R02UR	54249
385 - 512 Kbps CIR	--	60.00	CORUS	54208
Express PVC-1	--	75.00	R01US	54229
Express PVC-2	--	66.00	R02US	54250
513 - 768 Kbps CIR	--	70.00	CORUT	54220
Express PVC-1	--	87.50	R01UT	54230
Express PVC-2	--	77.00	R02UT	54251
769 - 1152 Kbps CIR	--	80.00	CORUU	54209
Express PVC-1	--	100.00	R01UU	54231
Express PVC-2	--	88.00	R02UU	54252
1153 - 1536 Kbps CIR	--	90.00	CORUV	54210
Express PVC-1	--	112.50	R01UV	54232
Express PVC-2	--	99.00	R02UV	54253

FILED

AUG 01 2000

00 - 182

MISSOURI

Public Service Commission

Issued: May 10, 2000

Effective: August 1, 2000

FACILITIES FOR INTRASTATE ACCESS

RECEIVED

16. ADVANCED COMMUNICATIONS NETWORKS (Cont'd)

MAY 10 2000

16.3 Frame Relay Service (Cont'd)

MISSOURI
Public Service Commission

(F) Rates and Charges (Cont'd)

	<u>Nonrecurring Charges</u>	<u>Monthly Rate</u>	<u>USOC</u>	<u>IOSC</u>
(7) <u>Frame Relay Permanent Virtual Circuit CIR Capacity, Each</u> <u>Based on CIR Requested</u> (Cont'd)				
1537 - 4000 Kbps CIR	--	\$120.00	CORUA	54211
Express PVC-1	--	150.00	R01UA	54233
Express PVC-2	--	132.00	R02UA	54254
4001 - 10000 Kbps CIR	--	250.00	CORUB	54212
Express PVC-1	--	312.50	R01UB	54234
Express PVC-2	--	275.00	R02UB	54255
10001 - 15000 Kbps CIR	--	330.00	CORUC	54213
Express PVC-1	--	412.50	R01UC	54235
Express PVC-2	--	363.00	R02UC	54256
15001 - 20000 Kbps CIR	--	410.00	CORUD	54214
Express PVC-1	--	512.50	R01UD	54236
Express PVC-2	--	451.00	R02UD	54257
20001 - 25000 Kbps CIR	--	490.00	CORUE	54215
Express PVC-1	--	612.50	R01UE	54237
Express PVC-2	--	539.00	R02UE	54258
25001 - 30000 Kbps CIR	--	570.00	CORUF	54216
Express PVC-1	--	712.50	R01UF	54238
Express PVC-2	--	627.00	R02UF	54259
30001 - 35000 Kbps CIR	--	650.00	CORUG	54217
Express PVC-1	--	812.50	R01UG	54239
Express PVC-2	--	715.00	R02UG	54260
35001 - 40000 Kbps CIR	--	730.00	CORUH	54218
Express PVC-1	--	912.50	R01UH	54240
Express PVC-2	--	803.00	R02UH	54261
40001 - 45000 Kbps CIR	--	800.00	CORUJ	54219
Express PVC-1	--	1000.00	R01UJ	54241
Express PVC-2	--	880.00	R02UJ	54262

FILED

AUG 01 2000
00 - 182

MISSOURI
Public Service Commission

Issued: May 10, 2000

Effective: August 1, 2000

CANCELLED
October 19, 2009
Missouri Public
Service Commission
TN-2010-0092; YI-2010-0175

Kenneth Matzdorff
Chief Operating Officer
Kansas City, Missouri

FACILITIES FOR INTRASTATE ACCESS

RECEIVED

16. ADVANCED COMMUNICATIONS NETWORKS (Cont'd)

MAY 10 2000

16.3 Frame Relay Service (Cont'd)

MISSOURI
Public Service Commission

(F) Rates and Charges (Cont'd)

(8) Public NNI, Based on CIR

	<u>Nonrecurring Charges</u>	<u>Monthly Rate</u>	<u>USOC</u>	<u>IOSC</u>
				54263 (NRC)
1 - 32 Kbps	\$20.00	\$ 20.00	N/A	54264
33 - 64 Kbps	20.00	25.00	N/A	54265
65 - 96 Kbps	20.00	30.00	N/A	54266
97 - 128 Kbps	20.00	35.00	N/A	54267
129 - 192 Kbps	20.00	40.00	N/A	54268
193 - 256 Kbps	20.00	50.00	N/A	54269
257 - 320 Kbps	20.00	55.00	N/A	54270
321 - 384 Kbps	20.00	60.00	N/A	54271
385 - 512 Kbps	20.00	70.00	N/A	54272
513 - 768 Kbps	20.00	80.00	N/A	54273
769 - 1,152 Kbps	20.00	90.00	N/A	54274
1,153 - 1,536 Kbps	20.00	105.00	N/A	54275
1,537 - 4,000 Kbps	20.00	135.00	N/A	54276
4,001 - 10,000 Kbps	20.00	290.00	N/A	54277
10,001 - 15,000 Kbps	20.00	410.00	N/A	54278
15,001 - 20,000 Kbps	20.00	510.00	N/A	54279
20,001 - 25,000 Kbps	20.00	610.00	N/A	54280
25,001 - 30,000 Kbps	20.00	700.00	N/A	54281
30,001 - 35,000 Kbps	20.00	775.00	N/A	54282
35,001 - 40,000 Kbps	20.00	875.00	N/A	54283
40,001 - 45,000 Kbps	20.00	975.00	N/A	54284

FILED

AUG 01 2000
00 - 182

MISSOURI
Public Service Commission

Issued: May 10, 2000

Effective: August 1, 2000

CANCELLED
October 19, 2009
Missouri Public
Service Commission

Kenneth Matzdorff
Chief Operating Officer
Kansas City, Missouri