

Tariff Schedule Applicable to  
Intrastate Switched Access Services

Furnished by

Airus, Inc.

Between Points Within the State of Missouri

This Tariff sets forth the service offerings, rates, terms and conditions applicable to the facilities-based and resold telecommunications services provided by Airus, Inc. ("Airus") throughout the State of Missouri in exchanges that are currently served by AT&T Missouri, Embarq, CenturyTel of Missouri and Spectra Communications, as listed in those companies' Missouri local exchange tariffs.

This tariff is on file with the Missouri Public Service Commission, and copies may be inspected, during normal business hours, at the Company's principal place of business 840 South Canal Street, 7<sup>th</sup> Floor, Chicago, IL 60607. The Company can be reached at (312) 878-4162.

Airus has been certified to operate as a Competitive Telecommunications Company Under the Revised Statutes of Missouri, pursuant to Order issued February 2, 2010, effective February 12, 2010 in Case No. LA-2010-0170.

---

Issued: April 11, 2014

Effective Date: May 11, 2014

Issued by:  
Vice President Regulatory Affairs  
Airus, Inc.  
840 South Canal Street, 7<sup>th</sup> Floor  
Chicago, IL 60607

FILED  
Missouri Public  
Service Commission  
LN-2014-0281; YL-2014-0406

**WAIVER OF STATUES AND COMMISSON RULES**

Airus, Inc. ("Airus") is classified as a competitive telecommunications company and the following statutory provisions and Commission rules have been waived with respect to the Company's provision of switched access telecommunications services as set forth herein:

**Statutes:**

392.210.2  
392.240.1  
392.270  
392.280  
392.290  
392.300  
392.310  
392.320  
392.330  
392.340

**Rules:**

4 CSR 240-3.550(4) Held Orders & (5) (A) Quarterly Service  
4 CSR 240-10.020  
4 CSR 240-30.040  
4 CSR 240-32.060  
4 CSR 240-32.070  
4 CSR 240-32.080  
  
4 CSR 240-33.040(1) through (3) & (5) through (10)  
4 CSR 240-33.045  
4 CSR 240-33.080(1)  
4 CSR 240-33.130(1) (4) and (5)

4 CSR 240-32.050(4) (B) provide "white page" telephone directories in the St. Louis and Kansas City metropolitan areas. As a competitive local exchange carrier operating in the St. Louis and Kansas City metropolitan areas, the Company is given a partial exemption from 4 CSR 240-32.050(4)(B), in that, when AT&T does not automatically deliver a directory to the Company's subscribers, the Company may discharge its obligation to distribute such directories by instructing its end-user customers to (a) contact the Company for a copy of the directory (who will in turn forward the request to AT&T; or, alternatively, (b) contact AT&T directly for a copy of the directory.

Issued: April 11, 2014

Effective Date: May 11, 2014

Issued by:  
Vice President Regulatory Affairs  
Airus, Inc.  
840 South Canal Street, 7<sup>th</sup> Floor  
Chicago, IL 60607

FILED  
Missouri Public  
Service Commission  
LN-2014-0281; YL-2014-0406

---

**TABLE OF CONTENTS**

---

TITLE SHEET ..... 1

WAIVER OF STATUES AND COMMISSION RULES..... 2

TABLE OF CONTENTS ..... 3

TARIFF FORMAT..... 4

EXPLANATION OF SYMBOLS AND REFERENCE  
MARKS USED IN THIS TARIFF ..... 5

DEFINITIONS ..... 6

1.0 APPLICATION OF TARIFF ..... 13

2.0 REGULATIONS ..... 14

    2.1 Undertaking of the Company ..... 14

    2.2 Prohibited Uses ..... 20

    2.3 Obligations of the Customer ..... 21

    2.4 Customer Equipment and Channels ..... 26

    2.5 Customer Deposits and Advance Payments ..... 27

    2.6 Payment Arrangements ..... 29

    2.7 Allowances for Interruptions in Service ..... 39

    2.8 Application of Rates ..... 44

    2.9 Individual Case Basis Offerings ..... 47

3.0 SERVICE AND RATE DESCRIPTIONS ..... 48

    3.1 Access Services ..... 48

4.0 RATES ..... 75

    4.1 Access Services ..... 75

---

Issued: April 11, 2014

Effective Date: May 11, 2014

Issued by:  
Vice President Regulatory Affairs  
Airus, Inc.  
840 South Canal Street, 7<sup>th</sup> Floor  
Chicago, IL 60607

FILED  
Missouri Public  
Service Commission  
LN-2014-0281; YL-2014-0406

---

**TARIFF FORMAT**

- A. **Page Numbering** - Page numbers appear in the upper right corner of the page. Pages are numbered sequentially. However, new pages are occasionally added to the tariff. When a new page is added between pages already in effect, a decimal is added. For example, a new page added between Page 14 and 15 would be 14.1.
- B. **Page Revision Numbers** - Revision numbers also appear in the upper right corner of each page. These numbers are used to determine the most current page version on file with the Commission. For example, the 4<sup>th</sup> revised Page 14 cancels the 3<sup>rd</sup> revised Page 14.
- C. **Paragraph Numbering Sequence** - There are various levels of paragraph coding. Each level of coding is subservient to its next higher level:
- 2
  - 2.1
  - 2.1.1
  - 2.1.1.1

---

Issued: April 11, 2014

Effective Date: May 11, 2014

Issued by:  
Vice President Regulatory Affairs  
Airus, Inc.  
840 South Canal Street, 7<sup>th</sup> Floor  
Chicago, IL 60607

FILED  
Missouri Public  
Service Commission  
LN-2014-0281; YL-2014-0406

**EXPLANATION OF SYMBOLS AND REFERENCE  
MARKS USED IN THIS TARIFF**

The following symbols will be used in this tariff for the purpose indicated below:

- (C) - To signify a changed regulation.
- (D) - To signify discontinued rate or regulation.
- (I) - To signify an increased rate.
- (M) - To signify a move in the location of text, without change.
- (N) - To signify a new rate, service, regulation or other text.
- (R) - To signify a reduction in rate
- (S) - To signify reissued material.
- (T) - To signify a change in text but no change in rate.

---

Issued: April 11, 2014

Effective Date: May 11, 2014

Issued by:  
Vice President Regulatory Affairs  
Airus, Inc.  
840 South Canal Street, 7<sup>th</sup> Floor  
Chicago, IL 60607

FILED  
Missouri Public  
Service Commission  
LN-2014-0281; YL-2014-0406

---

**DEFINITIONS**

Certain terms used generally throughout this tariff are described below.

**Advance Payment**

A payment required before the start of service.

**Access Services**

The Company's intrastate telephone services offered pursuant to this tariff.

**Automatic Number Identification (ANI)**

A multi-frequency, signaling common switching feature that provides the automatic transmission of a seven or ten digit number and information digits to the customers premise for calls originating in the LATA to identify the calling party or station.

**Central office**

The facility housing one (1) or more switching units in a telecommunications system which provides service to the general public and has the necessary equipment and operating arrangements for terminating and interconnecting customer lines and trunks or trunks only.

**Collocation**

An arrangement where the equipment of a local exchange carrier is installed and maintained at the premise of another LEC.

**Common Carrier**

Denotes any individual, partnership, association, joint- stock company, trust, government entity or corporation engaged for hire in intrastate communication by wire or radio, between two or more exchanges.

**Commission**

Missouri Public Service Commission, the State agency responsible for the regulation of telecommunications service within a particular state's border.

**Company**

Airus, Inc., the issuer of this tariff.

---

Issued: April 11, 2014

Effective Date: May 11, 2014

Issued by:  
Vice President Regulatory Affairs  
Airus, Inc.  
840 South Canal Street, 7<sup>th</sup> Floor  
Chicago, IL 60607

FILED  
Missouri Public  
Service Commission  
LN-2014-0281; YL-2014-0406

---

**DEFINITIONS (Cont'd.)****Customer**

The person, firm or corporation that orders from, uses or subscribes to the services in this tariff, and is responsible for the payment of charges and compliance with the Company's regulations.

**Digital Signal Level 1 (DS1)**

1.544 Mbps first level signal in the time division multiplex hierarchy. In the time division multiplexing hierarchy of the telephone network, DS1 is the initial level of multiplexing.

**Digital Signal Level 3 (DS3)**

The 44.736 Mbps third level in the time division multiplex hierarchy. In the time division multiplexing hierarchy of the telephone network, DS3 is defined as the third level of multiplexing.

**End Office**

With respect to each NPA-NXX code prefix assigned to the Company, the location of the Company's "end office" for purposes of this tariff will be the point of interconnection associated with an NPA-NXX code as listed in 2.8.2(A) following.

**End User**

A customer of telecommunications service who is not a telecommunications carrier.

**Exchange**

A unit generally smaller than a Market Service Area (MSA), established by a local service provider for the administration of communications services in the specific area. One or more exchanges comprise a MSA.

**Exchange Access Service**

A service provided by a local exchange telecommunications company which enables a telecommunications company or other customer to enter and exit the local exchange telecommunications network in order to originate or terminate interexchange telecommunications service.

---

Issued: April 11, 2014

Effective Date: May 11, 2014

Issued by:  
Vice President Regulatory Affairs  
Airus, Inc.  
840 South Canal Street, 7<sup>th</sup> Floor  
Chicago, IL 60607

FILED  
Missouri Public  
Service Commission  
LN-2014-0281; YL-2014-0406

---

**DEFINITIONS (Cont'd.)****Exchange Telephone Company**

Denotes any individual, partnership, association, joint-stock company, trust, or corporation engaged in providing switched communication within an exchange.

**Facility or Facilities**

Lines, conduits, ducts, poles, wires, cables, cross-arms, receivers, transmitters, instruments, machines, appliances, instrumentalities and all devices, real estate, easements, apparatus, property and routes used, operated, owned or controlled by a telecommunications company to facilitate the provision of telecommunications service.

**FCC**

The Federal Communications Commission

**Individual Case Basis**

A condition in which the regulations (if applicable), rates and charges for an offering under the provision of this tariff are developed based on the circumstance in each case

**Intrastate Access Service**

Provides for a two-point communications path between a Customer's premises or a collocated interconnection location and an end user's premises for originating and terminating calls within the state.

**Local Access and Transport Area (LATA)**

A Local Access and Transport Area established pursuant to the Modification of Final Judgment entered by the United States District Court for the District of Columbia in Civil Action No. 82-0192; or any other geographic area designated as a LATA in the NATIONAL EXCHANGE CARRIER ASSOCIATION, INC. TARIFF F.C.C. NO. 4.

**Local Exchange Routing Guide (LERG)**

The telecommunications industry database tool used to provision NPA/NNXs and provide routing information to facilitate call completion.

**Loss**

The value placed on injury or damages due to an accident caused by another's negligence, a breach of contract or other wrongdoing.

---

Issued: April 11, 2014

Effective Date: May 11, 2014

Issued by:  
Vice President Regulatory Affairs  
Airus, Inc.  
840 South Canal Street, 7<sup>th</sup> Floor  
Chicago, IL 60607

FILED  
Missouri Public  
Service Commission  
LN-2014-0281; YL-2014-0406



---

**DEFINITIONS (Cont'd.)****Meet Point Billing**

A situation when two or more exchange telephone companies are involved in the provisioning and billing of telecommunications service.

**MOUs**

Minutes of Use

**North American Numbering Plan (NANP)**

A three-digit area code (also known as a Number Plan Area (NPA), and a seven digit telephone number, made up of a three digit central office code and a four-digit station number. The NANP is administered by the North American Numbering Plan Administrator (NANPA).

**Nonrecurring Charges**

A one-time charge associated with given service or item of equipment which applies on a per-service and/or per item basis each time the service or item of equipment is provided.

**Percentage of Interstate Usage (PIU)**

The interstate jurisdictional use of a telecommunications service, as reported by the customer. This percentage is stated as a whole number percentage (a number from 0 through 100 percent) which is the best estimate of the percentage of the total use of the service that will be interstate in nature by the customer.

**Recurring Charges**

The monthly charges to the Customer for services, facilities and equipment which continue to apply for duration of the service.

**Service Commencement Date**

The first date on which the Company notifies the Customer that the requested service or facility is available for use, unless extended by the Customer's refusal to accept service which does not conform to standards set forth in the Service Order or this tariff in which case the Service Commencement Date is the date of the Customer's acceptance. The Company and the Customer may mutually agree on a substitute Service Commencement Date. If the Company does not have an executed Service Order from a Customer, the Service Commencement Date will be the first date on which the service or facility was used by a Customer.

---

Issued: April 11, 2014

Effective Date: May 11, 2014

Issued by:  
Vice President Regulatory Affairs  
Airus, Inc.  
840 South Canal Street, 7<sup>th</sup> Floor  
Chicago, IL 60607

FILED  
Missouri Public  
Service Commission  
LN-2014-0281; YL-2014-0406

---

**DEFINITIONS (Cont'd.)****Service Order**

The request for access services, either written or electronic, executed by the Customer and the Company in the format devised by the Company. Such a request for service by the customer and the acceptance of the request by the Company initiates the respective obligations of the parties as set forth therein and pursuant to this tariff, but the duration of the service is calculated from the Service Commencement Date. Should a Customer use the Company's access service without an executed Service Order, the Company will then request the Customer to submit a Service Order.

**Serving Wire Center**

The wire center from which the customer designated premises would normally obtain dial tone from the Company.

**Shared**

A facility or equipment system or subsystem that can be used simultaneously by several Customers.

**Signaling Transfer Point (STP)**

A specialized switch that provides SS7 network access and performs SS7 message routing and screening.

**Station**

A point of input to or output from the network, including a telephone instrument or other terminal device.

**Tandem**

A central office where trunks are interconnected to transmit telecommunications traffic between other central offices.

**Tandem Transit or Third Party Tandem Transit**

An arrangement that provides indirect Interconnection, via a third party's tandem, that is used by the Company and the Customer for the reciprocal exchange of local and IntraLATA Toll Traffic between their respective networks and/or service.

---

Issued: April 11, 2014

Effective Date: May 11, 2014

Issued by:  
Vice President Regulatory Affairs  
Airus, Inc.  
840 South Canal Street, 7<sup>th</sup> Floor  
Chicago, IL 60607

FILED  
Missouri Public  
Service Commission  
LN-2014-0281; YL-2014-0406

---

**DEFINITIONS (Cont'd.)****Telecommunications Service**

The transmission of information by wire, radio, optical cable, electronic impulses, or other similar means. The offering of Telecommunications for a fee directly to the public, or to such classes of users as to be effectively available directly to the public, provided through a system of switches, transmission equipment, or other facilities (or combination thereof) by which a subscriber can originate and terminate a Telecommunications Service, regardless of the facilities used. Telecommunications Service generally provides the Customer with a telephonic connection to, and a unique telephone number address on, the public switched telecommunications network, and enables such Customer to place or receive calls to all other stations served by the public switched telecommunications network. It also provides service within a telephone exchange or within a connected system of telephone exchanges within the same exchange area operated to furnish subscribers intercommunicating service of the character ordinarily furnished by a single exchange

**Telecommunications Company**

Refers to and includes telephone corporations as that term is used in the statutes of this state and every corporation, company, association, joint stock company or association, partnership and person, their lessees, trustees or receivers appointed by any court whatsoever, owning, operating, controlling or managing any facilities used to provide telecommunications service for hire, sale or resale within the State of Missouri.

**Toll Traffic**

Between stations in different exchange areas for which there is a separate charge not included in contracts for local exchange service.

**Transit Traffic Service**

An access service, including but not limited to all Section 251(b)(5) traffic, ISP-bound traffic, intraLATA toll traffic (not delivered to an IXC), and CMRS intraMTA traffic, in which the Company transits traffic originated by a third party who is not an End User or other user of the Company's local exchange or exchange access service through its wire centers to a Customer. Transit Traffic Service does not include 911, 411, 976, 311, 611, 500, 950, directory assistance, 0+ local, and 0+ operator services.

---

Issued: April 11, 2014

Effective Date: May 11, 2014

Issued by:  
Vice President Regulatory Affairs  
Airus, Inc.  
840 South Canal Street, 7<sup>th</sup> Floor  
Chicago, IL 60607

FILED  
Missouri Public  
Service Commission  
LN-2014-0281; YL-2014-0406

---

**DEFINITIONS (Cont'd.)**

**User**

A Customer or any other person authorized by the Customer to use service provided under this tariff.

**Wire Center**

A building in which one or more end offices, used for the provision of Exchange Services, are located.

---

Issued: April 11, 2014

Effective Date: May 11, 2014

Issued by:  
Vice President Regulatory Affairs  
Airus, Inc.  
840 South Canal Street, 7<sup>th</sup> Floor  
Chicago, IL 60607

FILED  
Missouri Public  
Service Commission  
LN-2014-0281; YL-2014-0406

---

**SECTION 1. APPLICATION OF TARIFF**

1.1 Application of Tariff

1.1.1 This tariff applies to intrastate access service supplied to Customers for origination and termination of traffic to and from Central Office codes directly assigned to Airus, Inc. and traffic from those central office codes assigned to other carriers that transits Airus' facilities. This tariff is applicable to the provision of services within the service areas and exchanges served by Southwestern Bell Telephone Company, Embarq, CenturyTel of Missouri and Spectra Communications.

1.1.2 Except as provided in 3.1.3(A), this tariff applies only to the extent that services provided hereunder are used by a Customer for the purpose of originating or terminating intrastate communications. A communication is "intrastate" only if all points of origination and termination are located within the State of Missouri.

---

Issued: April 11, 2014

Effective Date: May 11, 2014

Issued by:  
Vice President Regulatory Affairs  
Airus, Inc.  
840 South Canal Street, 7<sup>th</sup> Floor  
Chicago, IL 60607

FILED  
Missouri Public  
Service Commission  
LN-2014-0281; YL-2014-0406

---

**SECTION 2. REGULATIONS**

2.1 Undertaking of the Company

2.1.1 Scope

The Company undertakes to furnish access services in accordance with the terms and conditions set forth in this tariff.

2.1.2 Shortage of Facilities

All service is subject to the availability of suitable facilities. The furnishing of service under this tariff is subject to the availability on a continuing basis of all the necessary facilities and equipment and is limited to the capacity of the Company's facilities to furnish service as required at the sole discretion of the Company.

2.1.3 Terms and Conditions

- (A) Service is provided on the basis of a minimum period of at least one-month, 24-hours per day. For the purpose of computing charges in this tariff, a month is considered to have thirty (30) days.
- (B) The Company reserves the right to discontinue service, limit service, or to impose requirements when Customer is using the service in violation of the provisions of this tariff, or as required to meet changing regulatory or statutory rules and standards, or when such rules and standards have an adverse material affect of on the business or economic feasibility of providing service, as determined by the Company in its reasonable judgment.

---

Issued: April 11, 2014

Effective Date: May 11, 2014

Issued by:  
Vice President Regulatory Affairs  
Airus, Inc.  
840 South Canal Street, 7<sup>th</sup> Floor  
Chicago, IL 60607

FILED  
Missouri Public  
Service Commission  
LN-2014-0281; YL-2014-0406

---

**SECTION 2. REGULATIONS (Cont'd.)**

2.1 Undertaking of the Company

2.1.3 Terms and Conditions

- (C) In any action between the parties to enforce any provision of this tariff, the prevailing party will be entitled to recover its legal fees and court costs from the non-prevailing party in addition to other relief a court may award.
- (D) Customers may be required to enter into written service orders which will contain or reference a specific description of the service ordered, the rates to be charged, the duration of the services, and the terms and conditions in this tariff. Customers will also be required to execute any other documents as may be reasonably requested by the Company.
- (E) This tariff will be interpreted and governed by the laws of the State of Missouri without regard for its choice of laws provision.
- (F) The Company will perform routine tests, make traffic studies, and maintain records required to determine the facilities, equipment and personnel necessary to maintain an acceptable quality of service at all times.

---

Issued: April 11, 2014

Effective Date: May 11, 2014

Issued by:  
Vice President Regulatory Affairs  
Airus, Inc.  
840 South Canal Street, 7<sup>th</sup> Floor  
Chicago, IL 60607

FILED  
Missouri Public  
Service Commission  
LN-2014-0281; YL-2014-0406

---

**SECTION 2. REGULATIONS (Cont'd.)**

## 2.1 Undertaking of the Company (Cont'd.)

## 2.1.4 Liability of the Company

- (A) Except as otherwise stated in this Tariff, the liability of the Company for damages arising out of the furnishing of its Services, including but not limited to mistakes, omissions, interruptions, delays, or errors, or other defects, representations, or use of these services or arising out of the failure to furnish the service, whether caused by acts or omission, will be limited to the extension of allowances for interruption as set forth in Section 2.7. The extension of such allowances for interruption will be the sole remedy of the Customer and the sole liability of the Company. The Company will not be liable for any direct, indirect, incidental, special, consequential, exemplary or punitive damages to the Customer as a result of any Company service, equipment or facilities, or any acts or omissions or negligence of the Company's employees or agents.
- (B) The Company will not be liable for any delay or failure of performance or equipment due to causes beyond its control, including but not limited to: acts of God, fire, flood, explosion or other catastrophes; any law, order, regulation, direction, action, or request of the United States government, or of any other government, including state and local governments having or claiming jurisdiction over the Company, or of any department, agency, commission, bureau, corporation, or other instrumentality of any one or more of these federal, state, or local governments, or of any civil or military authority; national emergencies; insurrections; riots; wars; unavailability of rights-of-way materials; or strikes, lock-outs, work stoppages, or other labor difficulties.
- (C) The Company will not be liable for (a) any act or omission of any entity furnishing to the Company or to the Company's Customers facilities or equipment used for interconnection with Network Services; or (b) for the acts or omissions of common carriers or warehousemen.

---

Issued: April 11, 2014

Effective Date: May 11, 2014

Issued by:  
Vice President Regulatory Affairs  
Airus, Inc.  
840 South Canal Street, 7<sup>th</sup> Floor  
Chicago, IL 60607

FILED  
Missouri Public  
Service Commission  
LN-2014-0281; YL-2014-0406



---

**SECTION 2. REGULATIONS (Cont'd.)****2.1 Undertaking of the Company (Cont'd.)****2.1.4 Liability of the Company (Cont'd.)**

- (D) The Company will not be liable for any damages or losses due to the fault or negligence of the Company or due to the failure or malfunction of equipment or facilities provided by the Company or its third party suppliers.
- (E) The Company does not guarantee nor make any warranty with respect to installations it provides for use in an explosive atmosphere. The Customer indemnifies and holds the Company harmless from any and all loss, claims, demands, suits, or other action, or any liability whatsoever, whether suffered, made, instituted, or asserted by any other party or person(s), and for any loss, damage, or destruction of any property, whether owned by the Customer or others, caused or claimed to have been caused directly or indirectly by the installation, operation, failure to operate, maintenance, removal, presence, condition, location, or use of any installation so provided. The Company reserves the right to require each Customer to sign an agreement acknowledging acceptance of the provisions of this Section 2.1.4(E) as a condition precedent to such installations.
- (F) The Company is not liable for any defacement of or damage to Customer premises resulting from the furnishing of services or equipment on such Premises or the installation or removal thereof, unless such defacement or damage is caused by gross negligence or willful misconduct of the Company's agents or employees.
- (G) The Company will be indemnified, defended and held harmless by the Customer against any claim, loss or damage arising from Customer's use of services, involving claims for libel, slander, invasion of privacy, or infringement of copyright arising from the Customer's own communications.

---

Issued: April 11, 2014

Effective Date: May 11, 2014

Issued by:  
Vice President Regulatory Affairs  
Airus, Inc.  
840 South Canal Street, 7<sup>th</sup> Floor  
Chicago, IL 60607

FILED  
Missouri Public  
Service Commission  
LN-2014-0281; YL-2014-0406

---

**SECTION 2. REGULATIONS (Cont'd.)**

2.1 Undertaking of the Company (Cont'd.)

2.1.4 Liability of the Company (Cont'd.)

- (H) The entire liability for any claim, loss, damage or expense from any cause whatsoever will in no event exceed sums actually paid the Company by the Customer for the specific services in the month in which the event giving rise to the liability occurred. No action or proceeding against the Company will be commenced more than one year after the event giving rise to the liability occurred.
  
- (I) THE COMPANY MAKES NO WARRANTIES OR REPRESENTATIONS, EXPRESS OR IMPLIED EITHER IN FACT OR BY OPERATION OF LAW, STATUTORY OR OTHERWISE, INCLUDING WARRANTIES OF MERCHANTABILITY OR FITNESS FOR A PARTICULAR USE, EXCEPT THOSE EXPRESSLY SET FORTH HEREIN.

2.1.5 Claims

The Company will be indemnified and saved harmless by the Customer from and against all loss, liability, damage and expense, including reasonable counsel fees, due to claims of libel, slander, or infringement of copyright in connection with the material transmitted over the Company's facilities; and any other claim resulting from any act or omission of the Customer or end users of the Customer relating to the use of the Company's services or facilities.

---

Issued: April 11, 2014

Effective Date: May 11, 2014

Issued by:  
Vice President Regulatory Affairs  
Airus, Inc.  
840 South Canal Street, 7<sup>th</sup> Floor  
Chicago, IL 60607

FILED  
Missouri Public  
Service Commission  
LN-2014-0281; YL-2014-0406

---

**SECTION 2. REGULATIONS (Cont'd.)**

2.1 Undertaking of the Company (Cont'd.)

2.1.6 Provision of Equipment and Facilities

- (A) Except as otherwise indicated, customer-provided station equipment at the Customer's premises for use in conjunction with this service will be so constructed, maintained and operated as to work satisfactorily with the facilities of the Company.
- (B) The Company will not be responsible for the installation, operation or maintenance of any Customer-provided communications equipment. Where such equipment is connected to service furnished pursuant to this tariff, the responsibility of the Company will be limited to the furnishing of services under this tariff and to the maintenance and operation of such services in the proper manner. Subject to this responsibility, the Company will not be responsible for:
  - (1) the through transmission of signals generated by Customer-provided equipment or for the quality of, or defects in, such transmission; or
  - (2) the reception of signals by Customer-provided equipment; or
  - (3) network control signaling where such signaling is performed by Customer-provided network control signaling equipment.

2.1.7 Ownership of Facilities

Title to all facilities provided by Company in accordance with this tariff remains in the Company, its agents, contractors or suppliers.

---

Issued: April 11, 2014

Effective Date: May 11, 2014

Issued by:  
Vice President Regulatory Affairs  
Airus, Inc.  
840 South Canal Street, 7<sup>th</sup> Floor  
Chicago, IL 60607

FILED  
Missouri Public  
Service Commission  
LN-2014-0281; YL-2014-0406

---

**SECTION 2. REGULATIONS (Cont'd.)**

2.2 Prohibited Uses

- 2.2.1 The services the Company offers will not be used for any unlawful purpose or for any use for which the Customer has not obtained all required governmental approvals, authorization, licenses, consents and permits.
- 2.2.2 The Company may require applicants for service who intend to use the Company's offering for resale and/or for shared use to file a letter with the Company confirming that their use of the Company's offerings complies with relevant laws and regulations, policies, orders, and decisions.
- 2.2.3 The Company may require a Customer to immediately shut down its transmission if such transmission is causing interference to others.
- 2.2.4 A Customer, joint user, or authorized user may not assign, or transfer in any manner, the service or any rights associated with the service without the written consent of the Company. The Company will permit a Customer to transfer its existing service to another entity if the existing Customer has paid all charges owed to the Company for regulated access services. Such a transfer will be treated as a disconnection of existing service and installation of new service, and non-recurring installation charges as stated in this tariff will apply.

---

Issued: April 11, 2014

Effective Date: May 11, 2014

Issued by:  
Vice President Regulatory Affairs  
Airus, Inc.  
840 South Canal Street, 7<sup>th</sup> Floor  
Chicago, IL 60607

FILED  
Missouri Public  
Service Commission  
LN-2014-0281; YL-2014-0406

---

**SECTION 2. REGULATIONS (Cont'd.)**

2.3 Obligations of the Customer

2.3.1 Customer Premises Provisions

- (A) The Customer will provide the personnel, power and space required to operate all facilities and associated equipment installed on the premises of the Customer.
- (B) The Customer will be responsible for providing Company personnel access to premises of the Customer at any reasonable hour for the purpose of testing the facilities or equipment of the Company.

2.3.2 Liability of the Customer

The Customer will be liable for damages to the facilities of the Company caused by negligence or willful acts of its offices, employees, agents or contractors of the Customer where such negligence is not the direct result of the Company's negligence.

---

Issued: April 11, 2014

Effective Date: May 11, 2014

Issued by:  
Vice President Regulatory Affairs  
Airus, Inc.  
840 South Canal Street, 7<sup>th</sup> Floor  
Chicago, IL 60607

FILED  
Missouri Public  
Service Commission  
LN-2014-0281; YL-2014-0406

---

**SECTION 2. REGULATIONS (Cont'd.)****2.3 Obligations of the Customer (Cont'd.)****2.3.3 Jurisdictional Report Requirements**

- (A) For Feature Group D Switched Access Service(s), the Company, where jurisdiction can be determined from the call detail, will determine the projected interstate percentage as follows. For originating access minutes, the projected interstate percentage will be developed on a monthly basis by end office trunk group when the Feature Group D Switched Access Service access minutes are measured by dividing the measured interstate originating access minutes (the access minutes where the calling number is in one state and the called number is in another state) by the total originating access minutes when the call detail is adequate to determine the appropriate jurisdiction. For terminating access minutes, the Customer has the option to provide the Company with a projected PIU factor. Customers who provide a PIU factor will supply the Company with an interstate percentage of the Feature Group D terminating access minutes for each account to which the Customer may terminate traffic.

---

Issued: April 11, 2014

Effective Date: May 11, 2014

Issued by:  
Vice President Regulatory Affairs  
Airus, Inc.  
840 South Canal Street, 7<sup>th</sup> Floor  
Chicago, IL 60607

FILED  
Missouri Public  
Service Commission  
LN-2014-0281; YL-2014-0406

---

**SECTION 2. REGULATIONS (Cont'd.)****2.3 Obligations of the Customer (Cont'd.)****2.3.3 Jurisdictional Report Requirements (Cont'd.)****(A) (Cont'd.)**

Should the Customer not supply a terminating PIU Factor, the data used by the Company to develop the projected interstate percentage for originating access minutes will be used to develop projected interstate percentage for such terminating access minutes. When a Customer orders Feature Group D Switched Access Service, the Customer will supply a projected interstate percentage of use for each end office trunk group involved to be used in the event that originating call details are insufficient to determine the jurisdiction for the call. This percentage will be used by the Company as the projected interstate percentage for such call detail. For purposes of developing the projected interstate percentage, the Customer will utilize the same considerations as those set forth in Section 2.3.3(B) following.

The Company will designate the number obtained by subtracting the projected interstate percentage for originating and terminating access minutes from 100 ( $100 - \text{projected interstate percentage} = \text{intrastate percentage}$ ) as the projected intrastate percentage of use.

- (B) For purposes of developing the projected interstate percentage, the Customer will consider every call that enters the Customer's network at a point within the same state as the state where the called station is located to be intrastate and every call that enters the Customer's network at a point in a state different from the state in which the called station is located to be interstate.
- (C) These whole number percentages will be used by the Company to apportion the use, rates, and/or nonrecurring charges between interstate and intrastate until a revised report is received.

---

Issued: April 11, 2014

Effective Date: May 11, 2014

Issued by:  
Vice President Regulatory Affairs  
Airus, Inc.  
840 South Canal Street, 7<sup>th</sup> Floor  
Chicago, IL 60607

FILED  
Missouri Public  
Service Commission  
LN-2014-0281; YL-2014-0406

---

**SECTION 2. REGULATIONS (Cont'd.)****2.3 Obligations of the Customer (Cont'd.)****2.3.3 Jurisdictional Report Requirements (Cont'd.)**

- (D) The projected interstate percentage of use will be used to determine the charges as follows:

The number of access minutes for a trunk group will be multiplied by the projected interstate percentage of use to determine the interstate access minutes. (i.e., number of access minutes x projected interstate percentage of use = interstate access minutes). The number of interstate access minutes so determined will be subtracted from the total number of access minutes (i.e., number of access minutes - interstate access minutes = intrastate access minutes). The intrastate access minutes for the group will be billed as set forth in Section 5 following.

- (E) Effective on the first of January, April, July and October of each year, the Customer may update the jurisdictional reports that require a projected interstate percentage. The Customer will forward to the Company, to be received no later than 20 calendar days after the first of each such month, a revised report showing the interstate percentage of use for the past three months ending the last day of December, March, June and September, respectively, for each service arranged for interstate and intrastate use. Except as set forth in Section 2.3.3(A) preceding where jurisdiction can be determined from the recorded message detail, the revised report will serve as the basis for the next three months billing and will be effective on the bill date in the following month (i.e., February, May, August, and November) for that service. No prorating or back billing will be done based on the report. If the Customer does not supply the report, the Company will assume the percentage to be the same as that provided in the last quarterly report. For those cases in which a quarterly report has never been received from the Customer, the Company will assume the percentage to be the same as that provided in the order for service as set forth in Section 2.3.3(A) preceding.

---

Issued: April 11, 2014

Effective Date: May 11, 2014

Issued by:  
Vice President Regulatory Affairs  
Airus, Inc.  
840 South Canal Street, 7<sup>th</sup> Floor  
Chicago, IL 60607

FILED  
Missouri Public  
Service Commission  
LN-2014-0281; YL-2014-0406



---

**SECTION 2. REGULATIONS (Cont'd.)****2.3 Obligations of the Customer (Cont'd.)****2.3.3 Jurisdictional Report Requirements (Cont'd.)**

- (F) The Customer reported projected interstate percentage of use as set forth in Section 2.3.3(A) preceding will be used for the apportionment of any monthly rates or nonrecurring charges associated with Feature Groups B or D Switched Access Service until the end of the quarter during which the service was activated. Thereafter, a projected interstate percentage for such apportionment will be developed quarterly by the Company based on the data used to develop the projected interstate percentage of use as set forth in Section 2.3.3(A) preceding. Where call detail is insufficient to make such a determination, the Customer will be requested to project an interstate percentage of use to be used by the Company for such apportionment.
- (G) The Customer will keep sufficient detail from which the percentage of interstate use can be ascertained and upon request of the Company make the records available for inspection. Such a request will be initiated by the Company no more than once per year. The Customer will supply the data within thirty (30) calendar days of the Company request.
- (H) The Customer may provide an additional percentage of interstate use for Entrance Facility and Direct Trunked Transport subject to the reporting requirements previously listed in this section. The percentage of interstate use may be provided per individual facility or at the billing account level. Should the Customer not provide a percentage of interstate use, the Company will use the reported Feature Group D aggregated percentage of interstate use.
- (I) In the absence of both a customer provided PIU, and the necessary jurisdictional information in the call detail to determine jurisdiction, the default PIU will be zero.

---

Issued: April 11, 2014

Effective Date: May 11, 2014

Issued by:  
Vice President Regulatory Affairs  
Airus, Inc.  
840 South Canal Street, 7<sup>th</sup> Floor  
Chicago, IL 60607

FILED  
Missouri Public  
Service Commission  
LN-2014-0281; YL-2014-0406

---

**SECTION 2. REGULATIONS (Cont'd.)****2.4 Customer Equipment and Channels****2.4.1 Interconnection of Facilities**

- (A) In order to protect the Company's facilities and personnel and the service furnished to other Customers by the Company from potentially harmful effects, the signals applied to the Company's service will be such as not to cause damage to the facilities of the Company. Any special interface equipment necessary to achieve the compatibility between facilities of the Company and the channels or facilities of others will be provided at the Customer's expense.

**2.4.2 Inspections**

- (A) The Company may, upon notification to the Customer, at a reasonable time, make such tests and inspections as may be necessary to determine that the requirements regarding the equipment and interconnections are being complied with in respect to the installation, operation and maintenance of Customer-provided equipment and in the wiring of the connection of Customer channels to Company-owned facilities.
- (B) If the protective requirements in connections with Customer-provided equipment are not being complied with, the Company may take such action as necessary to protect its facilities and personnel and will promptly notify the Customer by registered mail in writing of the need for protective action. In the event that the Customer fails to advise the Company within 10 days after such notice is received or within the time specified in the notice that corrective action has been taken, the Company may take whatever additional action is deemed necessary, including canceling service, to protect its facilities and personnel from harm. The Company will upon request 24 hours in advance provide Customer with a statement of technical parameters that the Customer's equipment must meet.

---

Issued: April 11, 2014

Effective Date: May 11, 2014

Issued by:  
Vice President Regulatory Affairs  
Airus, Inc.  
840 South Canal Street, 7<sup>th</sup> Floor  
Chicago, IL 60607

FILED  
Missouri Public  
Service Commission  
LN-2014-0281; YL-2014-0406

---

**SECTION 2. REGULATIONS (Cont'd.)****2.5 Customer Deposits and Advance Payments****2.5.1 Advance Payments**

To safeguard its interests, the Company may require a Customer to make an advance payment before services and facilities are furnished. The advance payment will not exceed an amount up to two months of estimated monthly usage charges. In addition, where special construction is involved, the advance payment may also include an amount equal to the estimated non-recurring charges for the special construction and recurring charges (if any) for a period to be set between the Company and the Customer. The advance payment will be credited to the Customer's initial bill. An advance payment may be required in addition to a deposit.

**2.5.2 Deposits**

- (A) To safeguard its interests, the Company may require the Customer to make a deposit to be held as a guarantee for the payment of charges. A deposit does not relieve the Customer of the responsibility for the prompt payment of bills on presentation. The deposit will not exceed an amount equal to:
- (1) an estimated two months' customary use or estimated two months' bill where applicable. Customary use is calculated using charges for the previous three months' of service.
  - (2) the charges that would apply for the minimum payment period for a service or facility which has a minimum payment period of more than one month; except that the deposit may include an additional amount in the event that a termination charge is applicable.
- (B) A deposit may be required in addition to an advance payment.

---

Issued: April 11, 2014

Effective Date: May 11, 2014

Issued by:  
Vice President Regulatory Affairs  
Airus, Inc.  
840 South Canal Street, 7<sup>th</sup> Floor  
Chicago, IL 60607

FILED  
Missouri Public  
Service Commission  
LN-2014-0281; YL-2014-0406

---

**SECTION 2. REGULATIONS (Cont'd.)****2.5 Customer Deposits and Advance Payments (Cont'd.)****2.5.2 Deposits (Cont'd.)**

- (C) When a service or facility is discontinued, the amount of a deposit, if any, will be applied to the Customer's account and any credit balance remaining will be refunded. Before the service or facility is discontinued, the Company may, at its option, return the deposit or credit it to the Customer's account. If the amount of the deposit is insufficient to cover the balance due to the Customer's account, the Company retains the right to collect any amounts owing after the deposit has been applied plus any costs related to the collection of any remaining balance.

Deposits held will accrue interest at a rate specified by the Commission without deductions for any taxes on such deposits. Interest will not accrue on any deposit after the date on which reasonable effort has been made to return it to the Customer.

- (D) Return of Deposit

After satisfactory payment of all undisputed charges for a twelve month period the deposit with accrued interest will be promptly returned or credited against charges on subsequent bills. Upon termination of service, the deposit with accrued interest will be credited to the final bill and the balance will be returned within twenty-one (21) days to the customer.

---

Issued: April 11, 2014

Effective Date: May 11, 2014

Issued by:  
Vice President Regulatory Affairs  
Airus, Inc.  
840 South Canal Street, 7<sup>th</sup> Floor  
Chicago, IL 60607

FILED  
Missouri Public  
Service Commission  
LN-2014-0281; YL-2014-0406

---

**SECTION 2. REGULATIONS (Cont'd.)**

2.6 Payment Arrangements

2.6.1 Payment for Service

The Customer is responsible for the payment of all charges for facilities and services furnished by the Company to the Customer.

(A) Taxes

The Customer is responsible for payment of any sales, use, gross receipts, excise, access or other local, state and federal taxes, charges or surcharges (however, designated) (excluding taxes on the Company's net income) imposed on or based upon the provision, sale or use of Services.

---

Issued: April 11, 2014

Effective Date: May 11, 2014

Issued by:  
Vice President Regulatory Affairs  
Airus, Inc.  
840 South Canal Street, 7<sup>th</sup> Floor  
Chicago, IL 60607

FILED  
Missouri Public  
Service Commission  
LN-2014-0281; YL-2014-0406

---

**SECTION 2. REGULATIONS (Cont'd.)****2.6 Payment Arrangements (Cont'd.)****2.6.1 Payment for Service (Cont'd.)****(B) Surcharges, Fees and Assessments**

The Customer is responsible for payment of any surcharge, assessment or fee, including but not limited to universal service fees, 911 charges, right of way fees or other types of infrastructure fees, and regulatory assessments, where allowed by applicable law.

**2.6.2 Billing and Collection of Charges**

The Customer is responsible for payment of all charges incurred by the Customer or other users for services and facilities furnished to the Customer by the Company.

- (A) Non-recurring charges are due and payable within thirty (30) days after the date of the invoice.
- (B) The Company will present invoices for Recurring Charges monthly to the Customer, in advance of the month in which service is provided, and Recurring Charges will be due and payable within thirty (30) days after the date of the invoice. When billing is based upon customer usage, usage charges will be billed monthly for the preceding billing period.
- (C) When service does not begin on the first day of the month, or end on the last day of the month, the charge for the fraction of the month in which service was furnished will be calculated on a pro rate basis. For this purpose, every month is considered to have thirty (30) days.

---

Issued: April 11, 2014

Effective Date: May 11, 2014

Issued by:  
Vice President Regulatory Affairs  
Airus, Inc.  
840 South Canal Street, 7<sup>th</sup> Floor  
Chicago, IL 60607

FILED  
Missouri Public  
Service Commission  
LN-2014-0281; YL-2014-0406

---

**SECTION 2. REGULATIONS (Cont'd.)****2.6 Payment Arrangements (Cont'd.)****2.6.2 Billing and Collection of Charges (Cont'd.)**

- (D) Billing of the Customer by the Company will begin on the Service Commencement Date, which is the day on which the Company notifies the Customer that the service or facility is available for use, except that the Service Commencement Date may be postponed by mutual agreement of the parties, or if the service or facility does not conform to standards set forth in this tariff or the Service Order. Billing accrues through and includes the day that the service, circuit, arrangement or component is discontinued.
- (E) If any portion of the payment is received by the Company after the date due, or if any portion of the payment is received by the Company in funds which are not immediately available upon presentment, then a late payment penalty will be due to the Company. The late payment penalty will be the portion of the payment not received by the date due, multiplied by a late factor. The late factor will be the lesser of:
  - (1) a rate of 1.5 percent per month; or
  - (2) the highest interest rate which may be applied under state law for commercial transactions.
- (F) The Customer will be assessed a charge of twenty-five dollars (\$25.00) for each check submitted by the Customer to the Company which a financial institution refuses to honor.

---

Issued: April 11, 2014

Effective Date: May 11, 2014

Issued by:  
Vice President Regulatory Affairs  
Airus, Inc.  
840 South Canal Street, 7<sup>th</sup> Floor  
Chicago, IL 60607

FILED  
Missouri Public  
Service Commission  
LN-2014-0281; YL-2014-0406

---

**SECTION 2. REGULATIONS (Cont'd.)**

2.6 Payment Arrangements (Cont'd.)

2.6.2 Billing and Collection of Charges (Cont'd.)

- (G) Customers have up to 90 days (commencing 5 days after remittance of the bill) to initiate a dispute over charges or to receive credits. Customer may notify the Company by telephone, in person or submit a written claim describing the disputed amount. The Company will investigate and resolve all disputes within forty-five (45) days of receipt of the dispute and the Company's resolution of such a dispute is final. Any portion of a disputed amount deemed payable by the Company must be paid in full within ten (10) days of resolution or Customer's service may be subject to disconnection and late payment charges imposed on the overdue amount.
  
- (H) If service is disconnected by the Company in accordance with Section 2.6.3 following, and later restored, restoration of service will be subject to all applicable installation charges.

---

Issued: April 11, 2014

Effective Date: May 11, 2014

Issued by:  
Vice President Regulatory Affairs  
Airus, Inc.  
840 South Canal Street, 7<sup>th</sup> Floor  
Chicago, IL 60607

FILED  
Missouri Public  
Service Commission  
LN-2014-0281; YL-2014-0406



---

**SECTION 2. REGULATIONS (Cont'd.)****2.6.3 Discontinuance of Service for Cause**

The Company may disconnect service for any of the following reasons, without incurring any liability, provided it has notified the customer of its intent, in writing, as applicable to disconnect service and has allowed the customer a reasonable time of not less than ten (10) days, after the date on which the notice is mailed, in which to remove the cause for disconnection.

- (A) Upon nonpayment of any amounts owing to the Company.
- (B) Upon violation of any of the other material terms or conditions for furnishing service the Company may discontinue or suspend.
- (C) Upon condemnation of any material portion of the facilities used by the Company to provide service to a Customer or if a casualty renders all or any material portion of such facilities inoperable beyond feasible repair, the Company, by notice to the Customer, may discontinue or suspend service without incurring any liability.
- (D) Upon the Customer's insolvency, assignment for the benefit of creditors, filing for bankruptcy or reorganization, or failing to discharge an involuntary petition within the time permitted by law, the Company may immediately discontinue or suspend service without incurring any liability.
- (E) Upon any governmental prohibition or required alteration of the services to be provided or any violation of an applicable law or regulation, the Company may immediately discontinue service without incurring any liability.
- (F) In the event of fraudulent use of the Company's network, the Company may without notice suspend or discontinue service. The Customer will be liable for all related costs. The Customer will also be responsible for payment of any reconnection charges.

---

Issued: April 11, 2014

Effective Date: May 11, 2014

Issued by:  
Vice President Regulatory Affairs  
Airus, Inc.  
840 South Canal Street, 7<sup>th</sup> Floor  
Chicago, IL 60607

FILED  
Missouri Public  
Service Commission  
LN-2014-0281; YL-2014-0406

---

**SECTION 2. REGULATIONS (Cont'd.)**

2.6 Payment Arrangements (Cont'd.)

2.6.3 Discontinuance of Service for Cause (Cont'd.)

- (G) Upon the Company's discontinuance of service to the Customer under Section 2.6.3(A) or 2.6.3(B), the Company, in addition to all other remedies that may be available to the Company at law or in equity or under any other provision of this tariff, may declare all future monthly and other charges which would have been payable by the Customer during the remainder of the term for which such services would have otherwise been provided to the Customer to be immediately due and payable (discounted to present value at six percent).

2.6.4 Notice to Company for Cancellation of Service

Customers desiring to terminate service will provide Company thirty (30) days written notice of desire to terminate service. Notice should be sent to the following address:

Airus, Inc.  
Attention: Customer Care  
840 South Canal Street, 7<sup>th</sup> Floor  
Chicago, IL 60607

---

Issued: April 11, 2014

Effective Date: May 11, 2014

Issued by:  
Vice President Regulatory Affairs  
Airus, Inc.  
840 South Canal Street, 7<sup>th</sup> Floor  
Chicago, IL 60607

FILED  
Missouri Public  
Service Commission  
LN-2014-0281; YL-2014-0406

---

**SECTION 2. REGULATIONS (Cont'd.)****2.6 Payment Arrangements (Cont'd.)****2.6.5 Ordering, Rating and Billing of Access Services Where More Than One Exchange Telephone Company is Involved**

Meet point billing applies when more than one Exchange Telephone Company is involved in the provision of Access Service. All recurring and nonrecurring charges for services provided by each Exchange Telephone Company are billed under each company's applicable rates as set forth in Section 2.6.5 (A) following.

The Company accepts and adheres to the Ordering and Billing Forum guidelines, Multiple Exchange Carrier Access Billing (MECAB) and Multiple Exchange Carrier Ordering and Design (MECOD).

The Company will handle ordering, rating and billing of Access Services under this tariff where more than one Exchange Telephone Company is involved in the provision of Access Service as follows.

- (A) For Feature Group D Switched Access Service, when the first point of switching is not in the same Exchange Telephone Company's territory as the Customer premises, the Customer must supply a copy of the order to the Exchange Telephone Company in whose territory the Customer premises is located and any other Exchange Telephone Company(s) involved in providing the service.

Each Exchange Telephone Company will provide the portion of Local Transport to an interconnection point (IP) with another Exchange Telephone Company, and will bill the charges in accordance with its Access Service tariff. The rate for the Transport elements will be determined as set forth in (B) following. All other appropriate charges in each Exchange Telephone Company tariff are applicable.

---

Issued: April 11, 2014

Effective Date: May 11, 2014

Issued by:  
Vice President Regulatory Affairs  
Airus, Inc.  
840 South Canal Street, 7<sup>th</sup> Floor  
Chicago, IL 60607

FILED  
Missouri Public  
Service Commission  
LN-2014-0281; YL-2014-0406

---

**SECTION 2. REGULATIONS (Cont'd.)**

2.6 Payment Arrangements (Cont'd.)

2.6.5 Ordering, Rating and Billing of Access Services Where More Than One Exchange Telephone Company is Involved (Cont'd.)

(B) The Local Transport rate elements for services provided as set forth in Section 2.6.5 (A) preceding are determined as follows:

- (1) Determine the appropriate Switched Access Local Transport mileage by computing the airline mileage between the two ends of the Local Transport, as defined in 3.1.2 following. Determine the airline mileage for the Local Transport charge using the V&H method as set forth in Section 2.8.2 following.

---

Issued: April 11, 2014

Effective Date: May 11, 2014

Issued by:  
Vice President Regulatory Affairs  
Airus, Inc.  
840 South Canal Street, 7<sup>th</sup> Floor  
Chicago, IL 60607

FILED  
Missouri Public  
Service Commission  
LN-2014-0281; YL-2014-0406

---

**SECTION 2. REGULATIONS (Cont'd.)**

**SECTION 2. REGULATIONS (Cont'd.)**

2.6 Payment Arrangements (Cont'd.)

2.6.5 Ordering, Rating and Billing of Access Services Where More Than One Exchange Telephone Company is Involved (Cont'd.)

- (C) The interconnection points will be determined by the Exchange Telephone Companies involved. The billing percentage (BP) factor for the Company for the service between the involved offices is listed in the NATIONAL EXCHANGE CARRIER ASSOCIATION, INC. TARIFF F.C.C. NO. 4.
- (D) Should any changes be made to the meet point billing arrangements as set forth in Section 2.6.5 (A) preceding, the Company will give affected Customers thirty (30) days' notice.
- (E) Should the Company act as an intermediate, non-terminating local exchange carrier,

Local Transport rates, as determined in Section 2.6.5 (B) preceding, will not be applied to the meet point billing arrangement.

---

Issued: April 11, 2014

Effective Date: May 11, 2014

Issued by:  
Vice President Regulatory Affairs  
Airus, Inc.  
840 South Canal Street, 7<sup>th</sup> Floor  
Chicago, IL 60607

FILED  
Missouri Public  
Service Commission  
LN-2014-0281; YL-2014-0406

---

**SECTION 2. REGULATIONS (Cont'd.)****2.6 Payment Arrangements (Cont'd.)****2.6.6 Changes in Service Requested**

If the Customer makes or requests material changes in circuit engineering, equipment specifications, service parameters, premises locations, or otherwise materially modifies any provision of the application for service, the Customer's installation fees will be adjusted according to the term and conditions set forth in 3.1.1.2 following, Access Order Modifications.

**2.6.7 Customer Overpayment**

The Company will pay interest on a Customer overpayment. Customer overpayment will mean a payment to the Company in excess of the correct charges for service when caused by erroneous billing by the Company. The rate of interest will be the unadjusted interest rate paid on Customer deposits or the late payment penalty rate, whichever is greater. Interest will be paid from the date when the Customer overpayment was made, adjusted for any changes in the deposit interest rate or late payment penalty rate, and compounded monthly, until the date when the overpayment is refunded. No interest will be paid on Customer overpayments that are refunded within thirty (30) days after such overpayment is received by the Company.

---

Issued: April 11, 2014

Effective Date: May 11, 2014

Issued by:  
Vice President Regulatory Affairs  
Airus, Inc.  
840 South Canal Street, 7<sup>th</sup> Floor  
Chicago, IL 60607

FILED  
Missouri Public  
Service Commission  
LN-2014-0281; YL-2014-0406

---

**SECTION 2. REGULATIONS (Cont'd.)****2.7 Allowances for Interruptions in Service**

Except as set forth in 2.1.4(B) preceding and 2.7.2 following, interruptions in service, which are not due to the negligence of, or noncompliance with the provisions of this tariff by, the Customer or the operation or malfunction of the facilities, power or equipment provided by the Customer, will be credited to the Customer as set forth in 2.7.1 for the part of the service that the interruption affects.

**2.7.1 Credit for Interruptions**

- (A) A credit allowance will be made when an interruption occurs because of a failure of any component furnished by the Company under this tariff. An interruption period begins when the Customer reports a service, facility or circuit to be interrupted and releases it for testing and repair. An interruption period ends when the service, facility or circuit is operative. If the Customer reports a service, facility or circuit to be inoperative but declines to release it for testing and repair, it is considered to be impaired, but not interrupted.
- (B) For calculating credit allowances, every month is considered to have thirty (30) days. A credit allowance is applied on a pro rata basis against the rates specified hereunder and is dependent upon the length of the interruption. Only those facilities on the interrupted portion of the circuit will receive a credit.

---

Issued: April 11, 2014

Effective Date: May 11, 2014

Issued by:  
Vice President Regulatory Affairs  
Airus, Inc.  
840 South Canal Street, 7<sup>th</sup> Floor  
Chicago, IL 60607

FILED  
Missouri Public  
Service Commission  
LN-2014-0281; YL-2014-0406

---

**SECTION 2. REGULATIONS (Cont'd.)**

---

## 2.7 Allowances for Interruptions in Service (Cont'd.)

## 2.7.1 Credit for Interruptions (Cont'd.)

## (B) (Cont'd.)

A credit allowance will be given for interruptions of 30 minutes or more. Credit allowances will be calculated as follows:

## Interruptions of 24 Hours or Less

Length of Interruption	Interruption Period To Be Credited
Less than 30 minutes	None
30 minutes up to but not including 3 hours	1/10 Day
3 hours up to but not including 6 hours	1/5 Day
6 hours up to but not including 9 hours	2/5 Day
9 hours up to but not including 12 hours	3/5 Day
12 hours up to but not including 15 hours	4/5 Day
15 hours up to but not including 24 hours	One Day

Two or more interruptions of 15 minutes or more during any one 24-hour period will be considered as one interruption.

---

Issued: April 11, 2014

Effective Date: May 11, 2014

Issued by:  
Vice President Regulatory Affairs  
Airus, Inc.  
840 South Canal Street, 7<sup>th</sup> Floor  
Chicago, IL 60607

FILED  
Missouri Public  
Service Commission  
LN-2014-0281; YL-2014-0406



---

**SECTION 2. REGULATIONS (Cont'd.)**

2.7 Allowances for Interruptions in Service (Cont'd.)

2.7.1 Credit for Interruptions (Cont'd.)

(B) (Cont'd.)

**Interruptions Over 24 Hours and Less Than 72 Hours.**

Interruptions over 24 hours and less than 72 hours will be credited 1/5 day for each 3-hour period or fraction thereof. No more than one full day's credit will be allowed for any period of 24 hours.

**Interruptions Over 72 Hours.**

Interruptions over 72 hours will be credited 2 days for each full 24-hour period. No more than thirty (30) days credit will be allowed for any one-month period.

---

Issued: April 11, 2014

Effective Date: May 11, 2014

Issued by:  
Vice President Regulatory Affairs  
Airus, Inc.  
840 South Canal Street, 7<sup>th</sup> Floor  
Chicago, IL 60607

FILED  
Missouri Public  
Service Commission  
LN-2014-0281; YL-2014-0406

---

**SECTION 2. REGULATIONS (Cont'd.)**

2.7 Allowances for Interruptions in Services (Cont'd.)

2.7.2 Limitations on Allowances

No credit allowance will be made for:

- (A) interruptions due to the negligence of, or noncompliance with the provisions of this tariff by the Customer, authorized user, joint user, or other common carrier providing service connected to the service of the Company;
- (B) interruptions due to the negligence of any person other than the Company, including but not limited to the Customer or other common carriers connected to the Company's facilities;
- (C) interruptions due to the failure or malfunction of non-Company equipment;
- (D) interruptions of service during any period in which the Company is not given full and free access to its facilities and equipment for the purpose of investigating and correcting interruptions;
- (E) interruptions of service during a period in which the Customer continues to use the service on an impaired basis;
- (F) interruptions of service during any period when the Customer has released service to the Company for maintenance purposes or for implementation of a Customer order for a change in service arrangements; or
- (G) interruption of service due to circumstances or causes beyond the control of Company.

---

Issued: April 11, 2014

Effective Date: May 11, 2014

Issued by:  
Vice President Regulatory Affairs  
Airus, Inc.  
840 South Canal Street, 7<sup>th</sup> Floor  
Chicago, IL 60607

FILED  
Missouri Public  
Service Commission  
LN-2014-0281; YL-2014-0406

---

**SECTION 2. REGULATIONS (Cont'd.)**

2.7 Allowances for Interruptions in Service (Cont'd.)

2.7.3 Cancellation For Service Interruption

Cancellation or termination for service interruption is permitted only if any circuit experiences a single continuous outage of 8 hours or more or cumulative service credits equaling 16 hours in a continuous 12-month period. The right to cancel service under this provision applies only to the single circuit which has been subject to the outage or cumulative service credits.

---

Issued: April 11, 2014

Effective Date: May 11, 2014

Issued by:  
Vice President Regulatory Affairs  
Airus, Inc.  
840 South Canal Street, 7<sup>th</sup> Floor  
Chicago, IL 60607

FILED  
Missouri Public  
Service Commission  
LN-2014-0281; YL-2014-0406

---

**SECTION 2. REGULATIONS (Cont'd.)****2.8 Application of Rates**

The regulations set forth in this section govern the application of rates for services contained in other sections of this tariff.

**2.8.1 Charges Based on Duration of Use**

Customer traffic to end offices will be measured by the Company at end office switches. Originating and terminating calls will be measured by the Company to determine the basis for computing chargeable access minutes.

For originating calls over Feature Group D, usage measurement begins when the originating Feature Group D switch receives the first wink supervisory signal forwarded from the Customer's point of termination.

The measurement of originating call usage ends when the originating Feature Group D switch receives disconnect supervision from either the originating end user's end office, indicating the originating end user has disconnected, or the Customer's point of termination, whichever is recognized first by the switch.

For terminating calls over Feature Group D, the measurement of access minutes begins when the terminating Feature Group D switch receives answer supervision from the terminating end user's end office, indicating the terminating end user has answered.

The measurement of terminating call usage over Feature Group D ends when the terminating Feature Group D switch receives disconnect supervision from either the terminating end user's end office, indicating the terminating end user has disconnected, or the Customer's point of termination, whichever is recognized first by the switch.

Access minutes or fractions thereof are accumulated over the billing period for each end office and are then rounded up to the nearest access minute for each end office.

---

Issued: April 11, 2014

Effective Date: May 11, 2014

Issued by:  
Vice President Regulatory Affairs  
Airus, Inc.  
840 South Canal Street, 7<sup>th</sup> Floor  
Chicago, IL 60607

FILED  
Missouri Public  
Service Commission  
LN-2014-0281; YL-2014-0406

---

**SECTION 2. REGULATIONS (Cont'd.)**

2.8 Application of Rates (Cont'd.)

2.8.2 Rates Based Upon Distance

Where the charges for service are specified based upon distance, the following rules apply:

- (A) Distance between two points is measured as airline distance between the wire centers of the originating and terminating telephone lines. The wire center is a set of geographic coordinates, as referenced in the NATIONAL EXCHANGE CARRIER ASSOCIATION, INC. TARIFF FCC No. 4, associated with each NPA-NXX combination (where NPA is the area code and NXX is the first three digits of a seven-digit telephone number).

---

Issued: April 11, 2014

Effective Date: May 11, 2014

Issued by:  
Vice President Regulatory Affairs  
Airus, Inc.  
840 South Canal Street, 7<sup>th</sup> Floor  
Chicago, IL 60607

FILED  
Missouri Public  
Service Commission  
LN-2014-0281; YL-2014-0406

---

**SECTION 2. REGULATIONS (Cont'd.)**

## 2.8 Application of Rates (Cont'd.)

## 2.8.2 Rates Based Upon Distance (Cont'd.)

(B) The airline distance between any two wire centers is determined as follows:

- (1) Obtain the "V" and "H" coordinates for each wire center from the above-referenced NECA tariff.
- (2) Compute the difference between the "V" coordinates of the two wire centers; and the difference between the two "H" coordinates.
- (3) Square each difference obtained in step (2) above.
- (4) Add the square of the "V" difference and the square of the "H" difference obtained in step (3).
- (5) Divide the sum of the squares by 10. Round to the next higher whole number if any fraction is obtained.
- (6) Obtain the square root of the whole number result obtained above. Round to the next higher whole number if any fraction is obtained. This is the airline mileage.

(7) Formula = 
$$\sqrt{\frac{(V1 - V2)^2 + (H1 - H2)^2}{10}}$$

---

Issued: April 11, 2014

Effective Date: May 11, 2014

Issued by:  
Vice President Regulatory Affairs  
Airus, Inc.  
840 South Canal Street, 7<sup>th</sup> Floor  
Chicago, IL 60607

FILED  
Missouri Public  
Service Commission  
LN-2014-0281; YL-2014-0406

---

**SECTION 2. REGULATIONS (Cont'd.)****2.8 Application of Rates (Cont'd.)****2.8.3 Mileage**

The mileage to be used to determine the Local Transport monthly rates are calculated on the airline distance between the end office switch where the call carried by Local Transport originates or terminates and the customer's serving wire center. The V&H coordinates method is used to determine mileage. This method is set forth in Section 2.8.2.

The Local Transport Entrance Facility mileage rates are shown in Section 4.1.3 (A) in terms of per mile per access minute. To determine the rate to be billed, first compute the mileage. Should the calculation result in a fraction of a mile, the fraction will always be rounded up to the next whole mile before determining the mileage. Then multiply the mileage by the appropriate Local Transport rate. The amount to be billed will be the product of this calculation (i.e., the number of miles multiplied by the per mile rate) multiplied by the number of access minutes.

**2.9 Individual Case Basis ("ICB") Offerings**

Pursuant to Section 392.200.8 RSMO, Customer-specific Individual Case Basis (ICB) pricing is authorized only for: (1) dedicated, nonswitched, private line, and special access services, (2) central office based switching systems which substitute for customer premise, private branch exchange (PBX) services and (3) any retail business service. Company will provide copies of its customer contracts to the Staff, upon request, on a proprietary basis.

---

Issued: April 11, 2014

Effective Date: May 11, 2014

Issued by:  
Vice President Regulatory Affairs  
Airus, Inc.  
840 South Canal Street, 7<sup>th</sup> Floor  
Chicago, IL 60607

FILED  
Missouri Public  
Service Commission  
LN-2014-0281; YL-2014-0406

---

**SECTION 3. SERVICE AND RATE DESCRIPTIONS****3.1 Access Services**

Switched Access Service, which is available to Customers for their use in furnishing their services to end users, provides a two-point communications path between a Customer's premises (or a collocated interconnection location) and an end user's premises. It provides for the use of common terminating, switching and trunking facilities. Switched Access Service provides for the ability to originate calls from an end user's premises to a Customer's premises (or a collocated interconnection location), and to terminate calls from a Customer's premises (or a collocated interconnection location) to an end user's premises in the LATA where it is provided. Switched Access Service must be ordered separately for each LATA in which the customer desires to originate or terminate calls.

Switched Access Service is provided in the following service categories, which are differentiated by their technical characteristics and the manner in which an end user or Customer accesses them when originating or terminating calls.

FGD Access, which is available to all Customers, provides trunk side access to Company end office switches with an associated uniform 10XXX or 101XXXX access code for the Customer's use in originating and terminating communications. End users may also originate calls to a selected FGD Access Customer by dialing 1+NPA-NXX-XXXX when using the Company's presubscription service. Company may only terminate access to End Users who are connected to the Company.

Toll Free Data Base Access Service, which is available to all Customers, provides trunk side access to Company end office switches in the originating direction only, for the Customer's use in originating calls dialed by an end user to telephone numbers beginning with the prefix "800", "866", "888", or "877", for example. Toll Free Data Base Access Service is offered in conjunction with Feature Group D Access.

---

Issued: April 11, 2014

Effective Date: May 11, 2014

Issued by:  
Vice President Regulatory Affairs  
Airus, Inc.  
840 South Canal Street, 7<sup>th</sup> Floor  
Chicago, IL 60607

FILED  
Missouri Public  
Service Commission  
LN-2014-0281; YL-2014-0406



---

**SECTION 3. SERVICE AND RATE DESCRIPTIONS (Cont'd.)**

---

## 3.1 Access Services (Cont'd.)

## 3.1.1 Access Service Order

An Access Service Order is used by the Company to provide a Service. When placing an order for Access Service, the Customer will provide, at a minimum, the following information:

For Feature Group D Switched Access Service, the Customer will specify the number of busy hour minutes of capacity (BHMC) from the Customer's premises to the end office by traffic type. This information is used to determine the number of transmission paths. The Customer will also specify the Local Transport and Local Switching options. When FGD is ordered by specifying the number of trunks and direct routing to an end office is desired, the customer will specify:

- the end office and
- the Local Transport and Local Switching options desired.

When FGD is ordered by specifying the number of trunks and end office routing via an access tandem operated by another Exchange Telephone Company is desired, the customer will specify:

- the access tandem,
- the Local Transport and Local Switching options desired, and
- an estimate of the amount of traffic to be generated to and/or from each Company end office subtending another Exchange Telephone Company's access tandem.

---

Issued: April 11, 2014

Effective Date: May 11, 2014

Issued by:  
Vice President Regulatory Affairs  
Airus, Inc.  
840 South Canal Street, 7<sup>th</sup> Floor  
Chicago, IL 60607

FILED  
Missouri Public  
Service Commission  
LN-2014-0281; YL-2014-0406

---

**SECTION 3. SERVICE AND RATE DESCRIPTIONS (Cont'd.)**

## 3.1 Access Services (Cont'd.)

## 3.1.1 Access Service Order (Cont'd.)

For 800 Data Base Access Service, the Customer will order the service in accordance with the preceding provisions set forth for Feature Group D. If the Customer desires any of the optional features available with 800 Data Base Service, the Customer will so specify on the order for service.

## 3.1.1.1 Access Order Service Date Intervals

Access Service is provided with one of the following Service Date Intervals:

- Standard Interval
- Negotiated Interval
- Advance Order Interval

## (A) Standard Interval

A schedule of Standard Intervals applicable for Switched Access Services and is as follows:

Trunk Groups	Standard Interval
1 to 4 Trunks	28 Days
5 to 24 Trunks	30 Days

## (B) Negotiated Interval

The Company will negotiate a service date interval with the Customer when:

- (1) There is no Standard Interval for the service, or;
- (2) The quantity of Access Services orders exceeds the quantities specified in the Standard Intervals, or;

---

 Issued: April 11, 2014

Effective Date: May 11, 2014

Issued by:  
Vice President Regulatory Affairs  
Airus, Inc.  
840 South Canal Street, 7<sup>th</sup> Floor  
Chicago, IL 60607

FILED  
Missouri Public  
Service Commission  
LN-2014-0281; YL-2014-0406

---

**SECTION 3. SERVICE AND RATE DESCRIPTIONS (Cont'd.)**

3.1 Access Services (Cont'd.)

3.1.1 Access Service Order (Cont'd.)

3.1.1.1 Access Order Service Date Intervals (Cont'd.)

(B) Negotiated Interval (Cont'd.)

- (3) The Customer requests a service date beyond the applicable Standard Interval service date except as set forth in (C) following.

The Company will offer a service date based on the type and quantity of Access Services the Customer has requested. The Negotiated Interval may not exceed by more than six months the Standard Interval service date, or, when there is no Standard Interval, the Company offered service date. All services for which rates are applied on an individual case basis are provided with a Negotiated Interval.

Common Channel Signaling Access (CCSA) links will be provided on a Negotiated Interval. New or existing FGD trunks ordered with the SS7 signaling option will be provided on a Negotiated Interval.

---

Issued: April 11, 2014

Effective Date: May 11, 2014

Issued by:  
Vice President Regulatory Affairs  
Airus, Inc.  
840 South Canal Street, 7<sup>th</sup> Floor  
Chicago, IL 60607

FILED  
Missouri Public  
Service Commission  
LN-2014-0281; YL-2014-0406

**SECTION 3. SERVICE AND RATE DESCRIPTIONS (Cont'd.)**

3.1 Access Services (Cont'd.)

3.1.1 Access Service Order (Cont'd.)

3.1.1.1 Access Order Service Date Intervals (Cont'd.)

(B) Negotiated Interval (Cont'd.)

(3) (Cont'd.)

The addition and/or deletion of a Toll Free Access Service six digit customer identification NXX is provided with a Negotiated Interval. The addition of a Toll Free Access Service ten digit customer identification record to the Toll Free Access Service data base or the deletion of a Toll Free Access Service ten digit customer identification record from the Toll Free Access Service data base is provided with a Negotiated Interval.

Maximum Interval	
Initial Establishment of service where Customer is: - Not yet provided with any Trunk Group service in the LATA	6 Months
- Provided Trunk Group service in the LATA	90 Days

Issued: April 11, 2014

Effective Date: May 11, 2014

Issued by:  
Vice President Regulatory Affairs  
Airus, Inc.  
840 South Canal Street, 7<sup>th</sup> Floor  
Chicago, IL 60607

FILED  
Missouri Public  
Service Commission  
LN-2014-0281; YL-2014-0406

**SECTION 3. SERVICE AND RATE DESCRIPTIONS (Cont'd.)**

3.1 Access Services (Cont'd.)

3.1.1 Access Service Order (Cont'd.)

3.1.1.1 Access Order Service Date Intervals (Cont'd.)

(C) Advance Order Interval

When placing an Access Order, a Customer may request an Advance Order Interval for a service date of 12 to 24 months from the Application Date for the following services:

- A minimum of 24 voice grade equivalent Switched Access Service lines or trunks or 720 BHMCs

Orders for less than the minimum quantities will be accommodated under Standard or Negotiated Interval provisions. Advance Order Interval Access Orders are subject to all ordering conditions of Standard and Negotiated Interval Access Orders except for the following:

(1) Advance Payment

A nonrefundable Advance Payment will be calculated as follows:

Advance Payment (Nonrefundable)	The minimum monthly charge for the minimum period plus the applicable Nonrecurring Charges for the services ordered.
---------------------------------	--

This Advance Payment is due ten (10) working days from the date the Company confirms acceptance of the order, or on the Application Date, whichever date is the later date. If the Advance Payment is not received by such payment date, the order will be canceled.

Issued: April 11, 2014

Effective Date: May 11, 2014

Issued by:  
Vice President Regulatory Affairs  
Airus, Inc.  
840 South Canal Street, 7<sup>th</sup> Floor  
Chicago, IL 60607

FILED  
Missouri Public  
Service Commission  
LN-2014-0281; YL-2014-0406

---

**SECTION 3. SERVICE AND RATE DESCRIPTIONS (Cont'd.)**

---

## 3.1 Access Services (Cont'd.)

## 3.1.1 Access Service Order (Cont'd.)

## 3.1.1.1 Access Order Service Date Intervals (Cont'd.)

## (C) Advance Order Interval (Cont'd.)

## (1) Advance Payment (Cont'd.)

When the Access Services are connected on the service date, the Advance Payment will be applied, as a credit, to the Customer's billed service charges. When there has been a decrease in the number of services originally ordered, as set forth in (2) following, only the portion of the Advance Payment for services actually installed will be credited.

## (2) Cancellation or Partial Cancellation of an Advance Order Interval Access Order

When the Customer cancels an Access Order, the order will be withdrawn. The Advance Payment will not be credited or refunded.

Any decrease in the number of ordered Access Services will be treated as a partial cancellation, and the portion of the Advance Payment for the services canceled will not be credited or refunded.

---

Issued: April 11, 2014

Effective Date: May 11, 2014

Issued by:  
Vice President Regulatory Affairs  
Airus, Inc.  
840 South Canal Street, 7<sup>th</sup> Floor  
Chicago, IL 60607

FILED  
Missouri Public  
Service Commission  
LN-2014-0281; YL-2014-0406

---

**SECTION 3. SERVICE AND RATE DESCRIPTIONS (Cont'd.)**

---

## 3.1 Access Services (Cont'd.)

## 3.1.1 Access Service Order (Cont'd.)

## 3.1.1.2 Access Order Modifications

The Customer may request a modification of its Access Order at any time prior to notification by the Company that service is available for the Customer's use or prior to the service date, whichever is later.

Any increase in the number of Switched Access Service lines, trunks or busy hour minutes of capacity or CCSA signaling connections will be treated as a new Access Order (for the increased amount only).

## (A) Service Date Change Charge

Access Order service dates for the installation of new services or rearrangements of existing services may be changed, but the new service date may not exceed the original service date by more than thirty (30) calendar days. When, for any reason, the Customer indicates that service cannot be accepted for a period not to exceed thirty (30) calendar days, and the Company accordingly delays the start of service, a Service Date Change Charge will apply. If the Customer requested service date is more than thirty (30) calendar days after the original service date, the order will be canceled by the Company and reissued with the appropriate cancellation charges applied.

---

Issued: April 11, 2014

Effective Date: May 11, 2014

Issued by:  
Vice President Regulatory Affairs  
Airus, Inc.  
840 South Canal Street, 7<sup>th</sup> Floor  
Chicago, IL 60607

FILED  
Missouri Public  
Service Commission  
LN-2014-0281; YL-2014-0406

---

**SECTION 3. SERVICE AND RATE DESCRIPTIONS (Cont'd.)**

3.1 Access Services (Cont'd.)

3.1.1 Access Service Order (Cont'd.)

3.1.1.2 Access Order Modifications (Cont'd.)

(A) Service Date Change Charge (Cont'd.)

A Service Date Change Charge will apply, on a per order per occurrence basis, for each service date changed. The applicable charge is found in Section 4.1.1.

(B) Partial Cancellation Charge

Any decrease in the number of ordered Switched Access Service lines, trunks or busy hour minutes of capacity ordered with a Standard or Negotiated Interval Access Order will be treated as a partial cancellation and the charges as set forth in Section 3.1.1.3 following will apply. Partial cancellation charges do not apply to Advance Order Interval Access Orders.

---

Issued: April 11, 2014

Effective Date: May 11, 2014

Issued by:  
Vice President Regulatory Affairs  
Airus, Inc.  
840 South Canal Street, 7<sup>th</sup> Floor  
Chicago, IL 60607

FILED  
Missouri Public  
Service Commission  
LN-2014-0281; YL-2014-0406



---

**SECTION 3. SERVICE AND RATE DESCRIPTIONS (Cont'd.)****3.1 Access Services (Cont'd.)****3.1.1 Access Service Order (Cont'd.)****3.1.1.2 Access Order Modifications (Cont'd.)****(C) Design Change Charge**

The Customer may request a design change to the service ordered. A design change is any change to an Access Order which requires engineering review. Design changes do not include a change of customer premises, end user premises, end office switch, Feature Group type except for changes to Feature Group D. Changes of this nature will require the issuance of a new order and the cancellation of the original order with appropriate cancellation charges applied.

The Design Change Charge will apply on a per order per occurrence basis, for each order requiring a design change. The applicable charge is found in Section 4.1.1.

If a change of service date is required, the Service Date Change Charge will also apply.

**(D) DSO Order Expedite Charge**

The Company will impose an expedite charge on any order for circuits requested by the customer to be installed earlier than the standard interval for DSO orders. A charge of twenty-five dollars per DSO expedited, regardless of service address, will be assessed to the customer.

---

Issued: April 11, 2014

Effective Date: May 11, 2014

Issued by:  
Vice President Regulatory Affairs  
Airus, Inc.  
840 South Canal Street, 7<sup>th</sup> Floor  
Chicago, IL 60607

FILED  
Missouri Public  
Service Commission  
LN-2014-0281; YL-2014-0406

---

**SECTION 3. SERVICE AND RATE DESCRIPTIONS (Cont'd.)**

## 3.1 Access Services (Cont'd.)

## 3.1.1 Access Service Order (Cont'd.)

## 3.1.1.2 Access Order Modifications (Cont'd.)

## (E) Expedited Order Charge

When placing an Access Order for service(s) for which Standard Intervals exist, a Customer may request a service date that is prior to the Standard Interval service date. A Customer may also request an earlier service date on a pending Standard, Negotiated or Advance Order Interval Access Order. If the Company agrees to provide service on an expedited basis, an Expedited Order Charge will apply.

If the Company receives a request for an expedited service date at the time a Standard Interval Access Order is placed, the Expedited Order Charge is calculated by summing all the nonrecurring charges associated with the order and then dividing this total by the number of days in the Standard Interval. The charge is then applied on a per day of improvement basis, per order, but in no event will the charge exceed fifty percent of the total nonrecurring charges associated with the Access Order.

---

Issued: April 11, 2014

Effective Date: May 11, 2014

Issued by:  
Vice President Regulatory Affairs  
Airus, Inc.  
840 South Canal Street, 7<sup>th</sup> Floor  
Chicago, IL 60607

FILED  
Missouri Public  
Service Commission  
LN-2014-0281; YL-2014-0406

---

**SECTION 3. SERVICE AND RATE DESCRIPTIONS (Cont'd.)****3.1 Access Services (Cont'd.)****3.1.1 Access Service Order (Cont'd.)****3.1.1.3 Cancellation of an Access Order**

(A) A Customer may cancel an Access Order for the installation of service at any time prior to notification by the Company that services available for the Customer's use or prior to the service date, whichever is later. The cancellation date is the date the Company receives written or verbal notice from the Customer that the order is to be canceled. The verbal notice must be followed by written confirmation within ten (10) days. If a Customer or a Customer's end user is unable to accept Access Service within thirty (30) calendar days after the original service date, the Customer has the choice of the following options:

- The Access Order will be canceled and charges set forth in (B) following will apply, or
- Billing for the service will commence.

If no cancellation request is received within the specified thirty (30) calendar days, billing for the service will commence. In any event, the cancellation date or the date billing is to commence, as applicable, will be the 31st day beyond the original service date of the Access Order.

---

Issued: April 11, 2014

Effective Date: May 11, 2014

Issued by:  
Vice President Regulatory Affairs  
Airus, Inc.  
840 South Canal Street, 7<sup>th</sup> Floor  
Chicago, IL 60607

FILED  
Missouri Public  
Service Commission  
LN-2014-0281; YL-2014-0406

---

**SECTION 3. SERVICE AND RATE DESCRIPTIONS (Cont'd.)**

3.1 Access Services (Cont'd.)

3.1.1 Access Service Order (Cont'd.)

3.1.1.3 Cancellation of an Access Order (Cont'd.)

- (B) When a Customer cancels a Standard or Negotiated Interval Access Order for the installation of service, a Cancellation Charge will apply as follows:
- (1) When the Customer cancels an Access Order, a charge equal to the estimated provisioning costs incurred at a particular date for the service ordered by the Company will apply.
  - (2) If the Company misses a service date for a Standard or Negotiated Interval Access Order by more than thirty (30) days, due to circumstances such as acts of God, governmental requirements, work stoppages and civil commotions, the Customer may cancel the Access Order without incurring cancellation charges.

---

Issued: April 11, 2014

Effective Date: May 11, 2014

Issued by:  
Vice President Regulatory Affairs  
Airus, Inc.  
840 South Canal Street, 7<sup>th</sup> Floor  
Chicago, IL 60607

FILED  
Missouri Public  
Service Commission  
LN-2014-0281; YL-2014-0406

---

**SECTION 3. SERVICE AND RATE DESCRIPTIONS (Cont'd.)**

---

## 3.1 Access Services (Cont'd.)

## 3.1.1 Access Service Order (Cont'd.)

## 3.1.1.4 Minimum Period

- (A) The minimum period for which Access Service is provided and for which charges are applicable, is one month.
- (B) The following changes will be treated as a discontinuance of the existing service and an installation of a new service. All associated nonrecurring charges will apply for the new service.

The changes listed below are those which will be treated as a discontinuance and installation of service and for which a new minimum period will be established.

- (1) A move to a different building.
- (2) A change in type of service.
- (3) A change in Switched Access Service Interface Group.
- (4) A change in Switched Access Service traffic type.
- (5) A change in STP Access link.
- (6) A change in STP Port.
- (7) A change in Company-provided Switched Access Service to a Collocated Interconnection arrangement or vice versa.
- (8) A change to an existing Feature Group D Service to include the provision of 64 kbps Clear Channel Capability.

---

Issued: April 11, 2014

Effective Date: May 11, 2014

Issued by:  
Vice President Regulatory Affairs  
Airus, Inc.  
840 South Canal Street, 7<sup>th</sup> Floor  
Chicago, IL 60607

FILED  
Missouri Public  
Service Commission  
LN-2014-0281; YL-2014-0406

---

**SECTION 3. SERVICE AND RATE DESCRIPTIONS (Cont'd.)**

3.1 Access Services (Cont'd.)

3.1.1 Access Service Order (Cont'd.)

3.1.1.5 Minimum Period Charges

When Access Service is disconnected prior to the expiration of the minimum period, charges are applicable for the balance of the minimum period.

The Minimum Period Charge for monthly billed services will be determined as follows:

For Switched Access Service, the charge for a month or fraction thereof is equal to the applicable minimum monthly charge for the capacity.

All applicable nonrecurring charges for the service will be billed in addition to the Minimum Period Charge.

3.1.1.6 Nonrecurring Charges

Nonrecurring charges are one-time charges that apply for a specific work activity (i.e., installation or change to an existing service). Types of nonrecurring charges that apply for Switched Access Service are: installation of service and service rearrangements.

(1) Installation of Service

Nonrecurring charges apply to each Switched Access Service installed. For Switched Services ordered on a per trunk basis, the charge is applied per trunk or out of band signaling connection. For Switched Services ordered on a busy hour

---

Issued: April 11, 2014

Effective Date: May 11, 2014

Issued by:  
Vice President Regulatory Affairs  
Airus, Inc.  
840 South Canal Street, 7<sup>th</sup> Floor  
Chicago, IL 60607

FILED  
Missouri Public  
Service Commission  
LN-2014-0281; YL-2014-0406

---

**SECTION 3. SERVICE AND RATE DESCRIPTIONS (Cont'd.)**

---

## 3.1 Access Services (Cont'd.)

## 3.1.1 Access Service Order (Cont'd.)

## 3.1.1.6 Nonrecurring Charges (Cont'd.)

## (1) Installation of Service (Cont'd.)

minutes of capacity basis, the charge is also applied on a per trunk basis but the charge applies only when the capacity ordered requires the installation of an additional trunk(s). In addition, nonrecurring charges apply when an out of band signaling connection is installed for use with FGD.

## (2) Service Rearrangements

All changes to existing services other than changes involving administrative activities only will be treated as a discontinuance of the existing service and an installation of a new service. The nonrecurring charge described in (1) preceding will apply for this work activity. Moves that change the physical location of the point of termination are described below.

## (a) Moves Within the Same Building

When the move is to a new location within the same building, the charge for the move will be an amount equal to one half of the nonrecurring charge for the capacity affected. There will be no change in the minimum period requirements.

---

Issued: April 11, 2014

Effective Date: May 11, 2014

Issued by:  
Vice President Regulatory Affairs  
Airus, Inc.  
840 South Canal Street, 7<sup>th</sup> Floor  
Chicago, IL 60607

FILED  
Missouri Public  
Service Commission  
LN-2014-0281; YL-2014-0406

---

**SECTION 3. SERVICE AND RATE DESCRIPTIONS (Cont'd.)**

3.1 Access Services (Cont'd.)

3.1.1 Access Service Order (Cont'd.)

3.1.1.6 Nonrecurring Charges (Cont'd.)

(2) Service Rearrangements (Cont'd.)

(b) Moves to a Different Building

Moves to a different building will be treated as a discontinuance and start of service and all associated nonrecurring charges will apply. New minimum period requirements will be established for the new service. The Customer will also remain responsible for satisfying all outstanding minimum period charges for the discontinued service.

---

Issued: April 11, 2014

Effective Date: May 11, 2014

Issued by:  
Vice President Regulatory Affairs  
Airus, Inc.  
840 South Canal Street, 7<sup>th</sup> Floor  
Chicago, IL 60607

FILED  
Missouri Public  
Service Commission  
LN-2014-0281; YL-2014-0406



---

**SECTION 3. SERVICE AND RATE DESCRIPTIONS (Cont'd.)**

3.1 Access Services (Cont'd.)

3.1.2 Standard Rate Categories

The following rate categories apply to all forms of Switched except as stated in 3.1.3:

- Local Transport
- End Office Switching (Originating and Terminating)
- Tandem Switching (Originating and Terminating)

---

Issued: April 11, 2014

Effective Date: May 11, 2014

Issued by:  
Vice President Regulatory Affairs  
Airus, Inc.  
840 South Canal Street, 7<sup>th</sup> Floor  
Chicago, IL 60607

FILED  
Missouri Public  
Service Commission  
LN-2014-0281; YL-2014-0406

---

**SECTION 3. SERVICE AND RATE DESCRIPTIONS (Cont'd.)**

3.1 Access Services (Cont'd.)

3.1.2 Standard Rate Categories (Cont'd.)

(A) Local Transport

The Local Transport rate category provides for transmission facilities between the Customer's premises or collocated interconnection location and the Company's end office switch(es) where the Customer's traffic is switched to originate or terminate its communications.

Charges for Local Transport service are computed in accordance with Section 2.6.5 preceding (Ordering, Rating, and Billing of Access Services Where More Than One Exchange Telephone Company Is Involved). For purposes of determining Local Transport Mileage, distance will be measured from the wire center that normally serves the Customer's premises to the end office switch(es).

---

Issued: April 11, 2014

Effective Date: May 11, 2014

Issued by:  
Vice President Regulatory Affairs  
Airus, Inc.  
840 South Canal Street, 7<sup>th</sup> Floor  
Chicago, IL 60607

FILED  
Missouri Public  
Service Commission  
LN-2014-0281; YL-2014-0406

---

**SECTION 3. SERVICE AND RATE DESCRIPTIONS (Cont'd.)**

3.1 Access Services (Cont'd.)

3.1.2 Standard Rate Categories (Cont'd.)

(A) Local Transport (Cont'd.)

The Company will provide Direct Trunked Transport between a Customer's premises and the Company's end office switch(es) upon request. At the Customer's option, Entrance Facility, Direct Trunked Transport, and STP Link Transport, may be provided by the Company, by the Customer, or by another carrier. If Direct Trunk Transport facilities are terminated at a Company end office switch location by a Customer, or by another carrier on behalf of a Customer, Entrance Facility Termination charges as described in 3.1.2(A)(1) will apply, but no other Local Transport elements will be charged.

The following paragraphs describe the Local Transport rate elements.

Local Transport - Entrance Facility  
Transport Multiplexing  
Direct Trunked Transport

---

Issued: April 11, 2014

Effective Date: May 11, 2014

Issued by:  
Vice President Regulatory Affairs  
Airus, Inc.  
840 South Canal Street, 7<sup>th</sup> Floor  
Chicago, IL 60607

FILED  
Missouri Public  
Service Commission  
LN-2014-0281; YL-2014-0406

---

**SECTION 3. SERVICE AND RATE DESCRIPTIONS (Cont'd.)**

---

## 3.1 Access Service (Cont'd.)

## 3.1.2 Standard Rate Categories (Cont'd.)

## (A) Local Transport (Cont'd.)

## (1) Local Transport-Entrance Facility

A Local Transport-Entrance Facility provides the communication path between a Customer's premises and the Company serving wire center of that premises for the sole use of the Customer. The Local Transport-Entrance Facility category is comprised of a DS1 rate. A Local Transport-Entrance Facility is required whether the Customer's premises and the serving wire center are located in the same or different buildings.

DS1 facilities are available for Local Transport-Entrance Facilities and for Local Transport-Direct Trunked Transport facilities. A DS1 facility is capable of transmitting electrical signals at a nominal 1.544 Mbps, with the capability to channelize up to 24 voice-frequency transmission paths.

## (2) Local Transport - Multiplexing

The Local Transport - Multiplexing feature allows for a DS3 facility to be channelized into 28 DS1 services or for a DS1 facility to be channelized into 24 Voice Grade or Voice Grade equivalent services. Multiplexing is available at the serving wire center of the customer premises or a collocation location, or at the company's premises. The multiplexing rates and charges are set forth in Section 4.1.4.

---

Issued: April 11, 2014

Effective Date: May 11, 2014

Issued by:  
Vice President Regulatory Affairs  
Airus, Inc.  
840 South Canal Street, 7<sup>th</sup> Floor  
Chicago, IL 60607

FILED  
Missouri Public  
Service Commission  
LN-2014-0281; YL-2014-0406

---

**SECTION 3. SERVICE AND RATE DESCRIPTIONS (Cont'd.)**

## 3.1 Access Services (Cont'd.)

## 3.1.2 Standard Rate Categories (Cont'd.)

## (A) Local Transport (Cont'd.)

## (3) Local Transport- Direct Trunked Transport

The Local Transport-Direct Trunked Transport provides the transmission path from the serving wire center of the Customer's premises to an end office or as an option from the serving wire center to a tandem. This transmission path is dedicated to the use of a single Customer.

The Local Transport-Direct Trunked Transport rate category is comprised of a monthly fixed rate and a monthly per mile rate based on the facility provided. The fixed rate provides the circuit equipment at the ends of the transmission links. The per mile rate provides the transmission facilities, including intermediate transmission circuit equipment, between the end points of the circuit. The Local Transport- Direct Trunked Transport rate is the sum of the fixed rate and the per mile rate. For purposes of determining the per mile rate, mileage will be measured as airline mileage between the serving wire center of the Customer's premises and the end office or directly to the access tandem using the V&H coordinates method.

---

Issued: April 11, 2014

Effective Date: May 11, 2014

Issued by:  
Vice President Regulatory Affairs  
Airus, Inc.  
840 South Canal Street, 7<sup>th</sup> Floor  
Chicago, IL 60607

FILED  
Missouri Public  
Service Commission  
LN-2014-0281; YL-2014-0406

---

**SECTION 3. SERVICE AND RATE DESCRIPTIONS (Cont'd.)**

## 3.1 Access Services (Cont'd.)

## 3.1.2 Standard Rate Categories (Cont'd.)

## (B) End Office Switching (Originating and Terminating)

The End Office rate category provides the local end office switching and end user termination functions necessary to complete the transmission of Switched Access communications to and from the end users served by the Company's end office. The End Office rate category consists of the Local Switching rate element.

The Local Switching rate element provides for: a) the use of end office switching equipment; b) the terminations for the end user common lines terminating in the local end office; and c) the termination of a call at a Company Intercept operator or recording. The operator or recording tells a caller why a call, as dialed, could not be completed, and if possible, provides the correct number. Intercept rates are assessed to a Customer based on the total number of access minutes.

Automatic Number Identification (ANI) provides the automatic transmission of a seven or ten digit number and information digits to the Customer's premises for calls originating in the LATA, to identify the calling telephone number. The ANI feature is an end office software function which is associated on a call-by-call basis with (1) all individual transmission path in a trunk group routed directly between an end office and a Customer's premises or, where technically feasible, with (2) all individual transmission paths in a trunk group between an end office and an access tandem, and a trunk group between an access tandem and a Customer's premises. The Shared Switch Port provides for the termination of Tandem Switched Transport to an end office.

Access minutes for all Switched Access Service subject to the Shared Switch Port will be multiplied by the per minute rate set forth in Section 4.1.4.

---

Issued: April 11, 2014

Effective Date: May 11, 2014

Issued by:  
Vice President Regulatory Affairs  
Airus, Inc.  
840 South Canal Street, 7<sup>th</sup> Floor  
Chicago, IL 60607

FILED  
Missouri Public  
Service Commission  
LN-2014-0281; YL-2014-0406

**SECTION 3. SERVICE AND RATE DESCRIPTIONS (Cont'd.)**

3.1 Access Services (Cont'd.)

3.1.2 Standard Rate Categories (Cont'd.)

(B) End Office Switching (Originating and Terminating) - Diagram

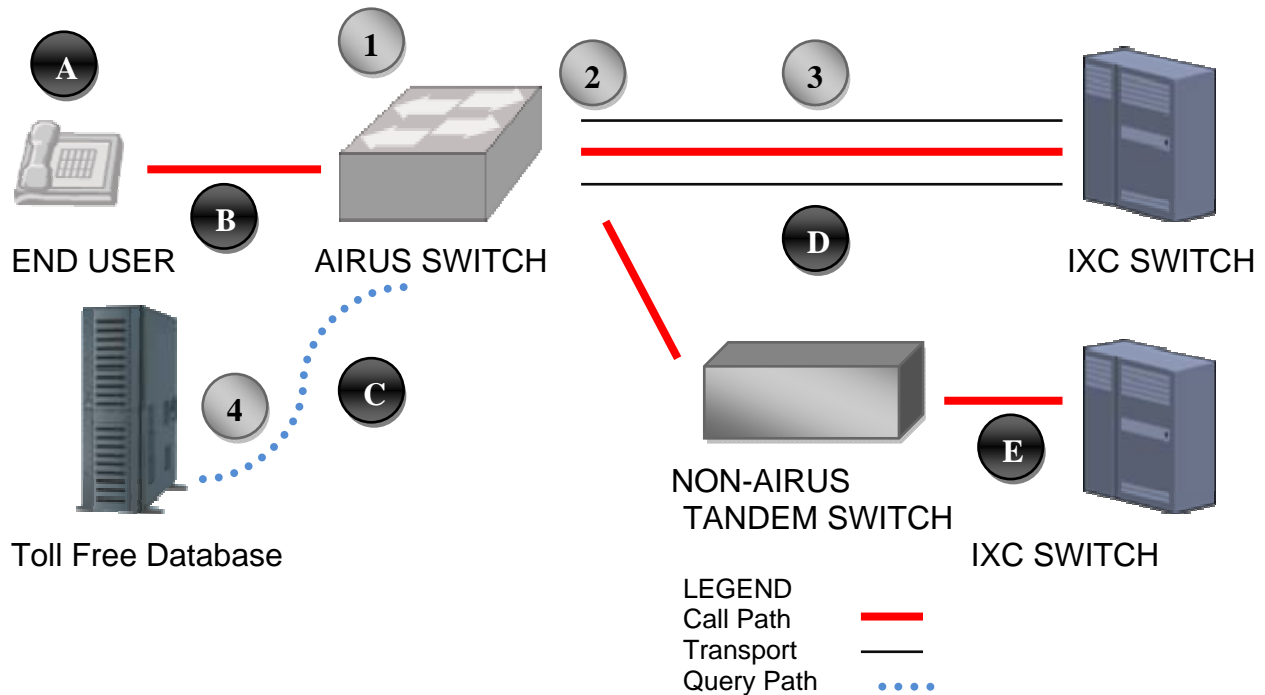

ORIGINATING CALL FLOW

- A. CLEC's End User places a long distance call.
- B. Call routes to Airus End Office Switch
- C. Call may require database query to determine proper routing.
- D. Call routes to appropriate IXC Switch directly for termination to customer; or
- E. Call routes to appropriate IXC Switch through Non-Airus Tandem Switch without any local transport

ORIGINATING CHARGES

- 1. End Office Switching (Originating)
- 2. Local Transport – Entrance Facility
- 3. Local Transport – Multiplexing and Direct Trunked Transport
- 4. Customer Identification Charge – Per Query

TERMINATING CALL FLOW

- D. IXC delivers terminating long distance call to CLEC over dedicated transport.
- A. Call routes to CLEC's End User.

TERMINATING CHARGES

- 1. End Office Switching (Terminating)
- 2. Local Transport – Entrance Facility
- 3. Local Transport – Multiplexing and Direct Trunked Transport

Issued: April 11, 2014

Effective Date: May 11, 2014

Issued by:  
Vice President Regulatory Affairs  
Airus, Inc.  
840 South Canal Street, 7<sup>th</sup> Floor  
Chicago, IL 60607

FILED  
Missouri Public  
Service Commission  
LN-2014-0281; YL-2014-0406

---

**SECTION 3. SERVICE AND RATE DESCRIPTIONS (Cont'd.)**

---

## 3.1 Access Services (Cont'd.)

## 3.1.2 Standard Rate Categories (Cont'd.)

## (C) Tandem Switching (Originating and Terminating)

Tandem Switching is an access service providing transmission and tandem switching between the Customer designated premises and the Company switch(es) where the Customer's traffic is switched from or to an entity other than an End User for purposes of originating or terminating the Customer's communications.

In addition to Tandem Switching, associated rate elements include:

Tandem Switching Transport Termination  
Tandem Switching Transport Facility  
Interconnection Charge

- (1) Tandem Switching Transport Termination  
This rate element applies to the non-distance sensitive portion of the Tandem Switched Transport for transmission facilities between the Company network and the end office.
- (2) Tandem Switching Transport Facility  
This rate element applies to the distance sensitive portion of the Tandem Switched Transport for transmission facilities between the Company network and the end office.
- (3) Interconnection Charge  
This rate element will be applied for interconnection with the Company's network for all Switched Access minutes of use that originate or terminate at a Company end office.

---

Issued: April 11, 2014

Effective Date: May 11, 2014

Issued by:  
Vice President Regulatory Affairs  
Airus, Inc.  
840 South Canal Street, 7<sup>th</sup> Floor  
Chicago, IL 60607

FILED  
Missouri Public  
Service Commission  
LN-2014-0281; YL-2014-0406



**SECTION 3. SERVICE AND RATE DESCRIPTIONS (Cont'd.)**

3.1 Access Services (Cont'd.)

3.1.2 Standard Rate Categories (Cont'd.)

(C) Tandem Switching (Originating and Terminating) – Diagram

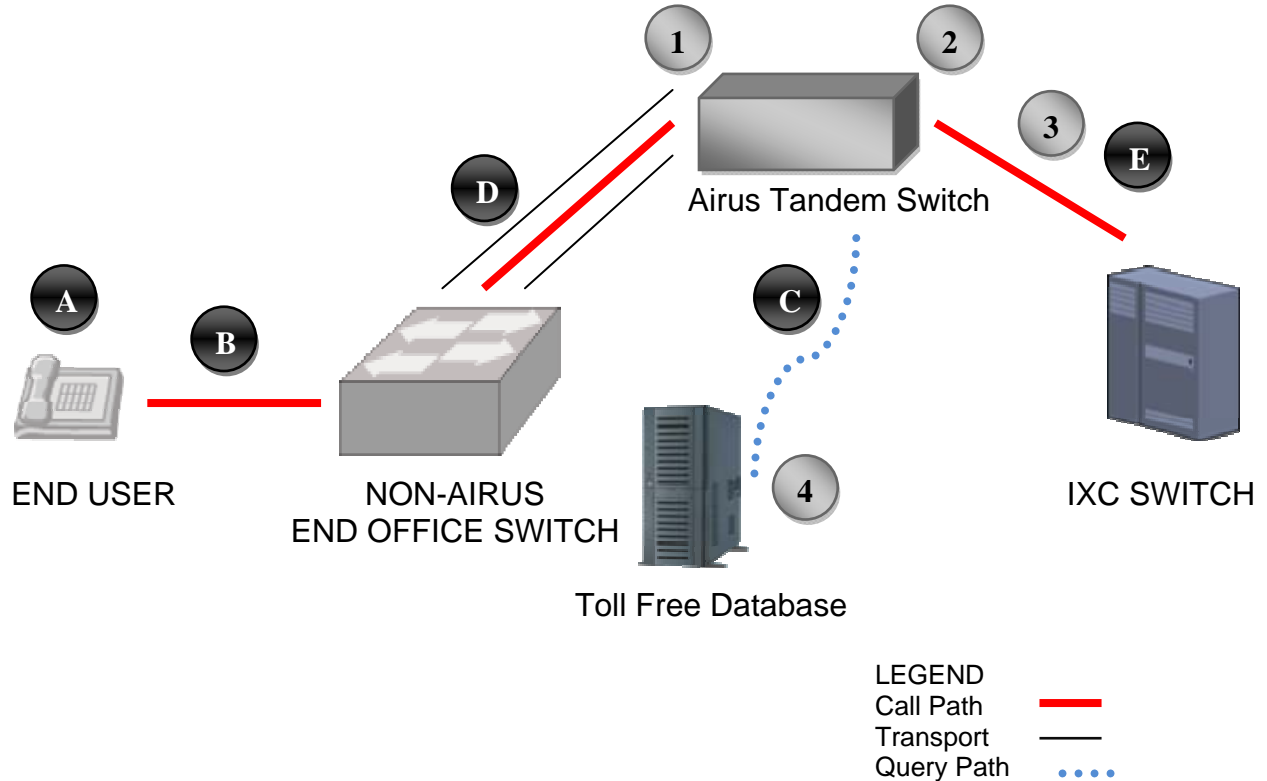

ORIGINATING CALL FLOW

- A. CLEC's End User places a long distance call.
- B. Call routes to Non-Airus End Office Switch
- C. Call may require database query to determine proper routing.
- D. Call routes to appropriate IXC Switch through the Airus Tandem Switch for termination to customer.

ORIGINATING CHARGES

- 1. Tandem Switching (Originating)
- 2. Local Transport – Entrance Facility
- 3. Local Transport – Multiplexing and Direct Trunked Transport
- 4. Customer Identification Charge – Per Query

TERMINATING CALL FLOW

- E. IXC delivers terminating long distance call to CLEC over dedicated transport.
- A. Call routes to CLEC's End User.

TERMINATING CHARGES

- 1. Tandem Switching (Terminating)
- 2. Local Transport – Entrance Facility
- 3. Local Transport – Multiplexing and Direct Trunked Transport

Issued: April 11, 2014

Effective Date: May 11, 2014

Issued by:  
Vice President Regulatory Affairs  
Airus, Inc.  
840 South Canal Street, 7<sup>th</sup> Floor  
Chicago, IL 60607

FILED  
Missouri Public  
Service Commission  
LN-2014-0281; YL-2014-0406

---

**SECTION 3. SERVICE AND RATE DESCRIPTIONS (Cont'd.)**

## 3.1 Access Services (Cont'd.)

## 3.1.3 Other Rates

## (A) Toll Free Data Base Access Service

Toll Free Data Base Access Service is a service offering utilizing originating trunk side Switched Access Service. The service provides for the forwarding of end user dialed toll free calls to a Company Service Switching Point which will initiate a query to the database to perform the Customer identification and delivery function. The call is forwarded to the appropriate Customer based on the dialed toll free number. Any dial around compensation relating to pay telephones will be billed in accordance to procedures and rates proscribed by the Federal Communications Commission. The Company reserves the right to bill end users of its toll free service for any dial around compensation costs the Company may incur.

## (1) Customer Identification Charge

The Toll Free Data Base Access Service Customer Identification applies for the identification of the appropriate Customer. The charge is assessed to the Customer on a per query basis and may include an area of service which may range from a single NPA/NXX to an area consisting of all LATAs and NPAs in the State of Missouri.

## (2) Toll Free Number Reservation

The Toll Free Number Reservation service applies to the request of the Customer to have the Company attempt to reserve a specific toll free number for the Customer. The Company will not guarantee that a specific toll free number in any of the toll free prefixes (800, 877, 888, 866 or future prefixes as designated by NANPA) will be available at the time a Customer requests the specific number.

---

Issued: April 11, 2014

Effective Date: May 11, 2014

Issued by:  
Vice President Regulatory Affairs  
Airus, Inc.  
840 South Canal Street, 7<sup>th</sup> Floor  
Chicago, IL 60607

FILED  
Missouri Public  
Service Commission  
LN-2014-0281; YL-2014-0406

**SECTION 4. RATES**

## 4.1 Access Service

4.1.1	Service Orders	Nonrecurring
(A)	Service Implementation	
(1)	Installation Charge	
	- Per trunk	\$ 15.00
(2)	Access Order Charge	
	- Per Access Request	\$125.00
(B)	Service Date Change	
	- Per Access Order	\$ 25.00
(C)	Design Change	
	- Per Access Order	\$ 25.00
(D)	DSO Expedite Charge	
	- Per DSO Order	\$ 25.00
4.1.2	Switched Access Service	Per Access Minute
	Tandem Switching (Originating) [Note 2]	\$0.000288
	Tandem Switching (Terminating) [Note 1]	***
	End Office Switching (Originating) [Note 2]	\$0.001342
	End Office Switching (Terminating) [Note 1]	***
4.1.2.1	Tandem Switching Transport [Note 1, 2]	
	Termination – Fixed (Originating)	\$0.000053
	Termination – Fixed (Terminating)	***
	Facility – Per Mile (Originating)	\$0.000003
	Facility – Per Mile (Terminating)	***
	Interconnection Charge	\$0.000000

\*\*\* Note 1: Denotes intrastate switched access rate elements that mirror the Company's (T)  
corresponding interstate access rates. See, Airus, Inc. FCC Tariff No. 1, Section 5.2.2. (T)  
Available at: <https://www.airustel.com/tariffs>

\*\*\*Note 2: Rates for Toll Free Originating Access Service mirror the corresponding (C)  
interstate rates found in Airus, Inc. FCC Tariff No. 1, Section 5.2.2(C). (C)

Issued: June 16, 2021

Effective Date: July 1, 2021

Issued by:  
Vice President Regulatory Affairs  
Airus, Inc.  
840 South Canal Street, 7<sup>th</sup> Floor  
Chicago, IL 60607

FILED  
Missouri Public  
Service Commission  
JL-2021-0235

---

**SECTION 4. RATES (Cont'd.)**

---

## 4.1 Access Service (Cont'd.)

## 4.1.3 Local Transport

## (A) Entrance Facility

(1)	DS1 -Per Point of Termination	Nonrecurring	Monthly Rate \$200.00
	Installation Charge	\$500.00	
(2)	DS3 -Per Point of Termination	Nonrecurring	Monthly Rate \$2,200.00
	Installation Charge	\$700.00	

## (B) Direct Trunked Transport

Facility Mileage	Monthly Rate	Per Mile
DS1	\$70.00	\$20.00
DS3	\$650.00	\$115.00

## (C) Multiplexing

	Monthly Rate
Multiplexing DS3 to DS1	\$131.25

---

Issued: April 11, 2014

Effective Date: May 11, 2014

Issued by:  
Vice President Regulatory Affairs  
Airus, Inc.  
840 South Canal Street, 7<sup>th</sup> Floor  
Chicago, IL 60607

FILED  
Missouri Public  
Service Commission  
LN-2014-0281; YL-2014-0406

---

**SECTION 4. RATES (Cont'd.)**

---

## 4.1 Access Service (Cont'd.)

## 4.1.4 Port and Cross Connect Charges

		Monthly Recurring Charge
(A)	Shared Switch Port Per DSI Port	\$ 54.00
(B)	Cross Connect Per DS1 connected	\$ 25.00

## 4.1.5 Toll Free Data Base Access Service

		Rate	
(A)	Customer Identification Charge - Per Query	***	(R,C)
(B)	Toll Free Number Reservation - Per Number Reserved	\$1.00	

\*\*\* Denotes intrastate switched access rates that mirror the corresponding interstate access rates. See, Airus, Inc. FCC Tariff No. 1, Section 5. (T)  
(T)

---

Issued: June 17, 2022

Effective Date: August 2, 2022

Issued by:  
Vice President Regulatory Affairs  
Airus, Inc.  
840 South Canal Street, 7<sup>th</sup> Floor  
Chicago, IL 60607

FILED  
Missouri Public  
Service Commission  
JL-2022-0279