

ACCESS SERVICE

2. General Regulations (Cont'd)

2.4 Payment Arrangements and Credit Allowances (Cont'd)

2.4.1 Payment of Rates, Charges and Deposits (Cont'd)

(B) (Cont'd)

- (3) (a) All bills dated as set forth in (2) pre-ceding for service, other than End User Access Service and Presubscription, provided to the customer by the Telephone Company are due 31 days (payment date) after the billing day or by the next bill date (i.e., same date in the following month as the bill date whichever is the shortest interval except as provided herein, and are payable in immediately available funds. If such payment date would cause payment to be due on a Saturday, Sunday or Holiday (i.e., New Year's Day, Independence Day, Labor Day, Thanksgiving Day, Christmas Day, the second Tuesday in November and a day when Washington's Birth-day, Memorial Day or Columbus Day is legally observed), payment for such bills will be due from the customer as follows:

If such payment date falls on a Sunday or on a Holiday which is observed on a Monday, the payment date shall be the first non-Holiday day following such Sunday or Holiday. If such payment date falls on a Saturday or on a Holiday which is observed on Tuesday, Wednesday, Thursday or Friday, the payment date shall be the last non-Holiday day preceding such Saturday or Holiday.

- (b) Further, if any portion of the payment is received by the Telephone Company after the payment date as set forth in (a) preceding, or if any portion of the payment is received by the Telephone Company in funds which are not immediately available to the Telephone Company, then a late payment penalty shall be due to the Telephone Company. The late payment penalty shall be the portion of the payment not received by the payment date times an interest factor. The interest factor shall be the lesser of:

ISSUED:
March 30, 2007

Mark D. Harper
Director - State Regulatory
5454 W. 110th Street
Overland Park, Kansas 66211

EFFECTIVE:
April 30, 2007

UNITED TELEPHONE COMPANY
OF MISSOURI

Original Page 51

ACCESS SERVICE

RECEIVED

SEP 17 1992

2. General Regulations (Cont'd)2.4 Payment Arrangements and Credit Allowances (Cont'd)2.4.1 Payment of Rates, Charges and Deposits (Cont'd)

(B) (Cont'd)

- (3)(a) All bills dated as set forth in (2) preceding for service, other than End User Access Service and Presubscription, provided to the customer by the Telephone Company are due 31 days (payment date) after the billing day or by the next bill date (i.e., same date in the following month as the bill date whichever is the shortest interval except as provided herein, and are payable in immediately available funds. If such payment date would cause payment to be due on a Saturday, Sunday or Holiday (i.e., New Year's Day, Independence Day, Labor Day, Thanksgiving Day, Christmas Day, the second Tuesday in November and a day when Washington's Birthday, Memorial Day or Columbus Day is legally observed), payment for such bills will be due from the customer as follows:

If such payment date falls on a Sunday or on a Holiday which is observed on a Monday, the payment date shall be the first non-Holiday day following such Sunday or Holiday. If such payment date falls on a Saturday or on a Holiday which is observed on Tuesday, Wednesday, Thursday or Friday, the payment date shall be the last non-Holiday day preceding such Saturday or Holiday.

- (b) Further, if any portion of the payment is received by the Telephone Company after the payment date as set forth in (a) preceding, or if any portion of the payment is received by the Telephone Company in funds which are not immediately available to the Telephone Company, then a late payment penalty shall be due to the Telephone Company. The late payment penalty shall be the portion of the payment not received by the payment date times an interest factor. The interest factor shall be the lesser of:

ISSUED:
September 17, 1992

BY: John L. Roe
Vice President - Administration
5454 West 110th Street
Overland Park, Kansas 66211

EFFECTIVE:
~~October 17, 1992~~
NOV 7 1992

Cancelled

April 30, 2007
Missouri Public
Service Commission

ACCESS SERVICE

2. General Regulations (Cont'd)

2.4 Payment Arrangements and Credit Allowances (Cont'd)

2.4.1 Payment of Rates, Charges and Deposits (Cont'd)

(B) (Cont'd)

(3) (Cont'd)

(b) (Cont'd)

(I) the highest interest rate (in decimal value) which may be levied by law for commercial transactions, compounded daily for the number of days from the payment date to and including the date that the customer actually makes the payment to the Telephone Company, or

(II) 0.000407 per day, compounded daily for the number of days from the payment date to and including the date that the customer actually makes the payment to the Telephone Company. (R)

(c) In the event that a billing dispute concerning any charges billed to the customer by the Telephone Company is resolved in favor of the Telephone Company, any payments withheld pending settlement of the dispute shall be subject to the late payment interest charge set forth in (b) preceding. If the customer disputes the bill on or before the payment date, and pays the undisputed amount on or before the payment date, any late payment charge for the disputed amount will not start until 10 working days after the payment date. If the billing dispute is resolved in favor of the customer, no late payment penalty will apply to the disputed amount.

(M)
—
(M)

(M) Material previously found on this page was moved to Page 53.

ISSUED:
February 27, 2017

Gary L. Kepley
Director, Regulatory Operations
600 New Century Parkway
New Century, Kansas 66031

EFFECTIVE:
April 1, 2017

17-02A

ACCESS SERVICE

2. General Regulations (Cont'd)

2.4 Payment Arrangements and Credit Allowances (Cont'd)

2.4.1 Payment of Rates, Charges and Deposits (Cont'd)

(B) (Cont'd)

(3) (Cont'd)

(b) (Cont'd)

(I) the highest interest rate (in decimal value) which may be levied by law for commercial transactions, compounded daily for the number of days from the payment date to and including the date that the customer actually makes the payment to the Telephone Company, or

(II) 0.000590 per day, compounded daily for the number of days from the payment date to and including the date that the customer actually makes the payment to the Telephone Company.

(c) In the event that a billing dispute concerning any charges billed to the customer by the Telephone Company is resolved in favor of the Telephone Company, any payments withheld pending settlement of the dispute shall be subject to the late payment interest charge set forth in (b) preceding. If the customer disputes the bill on or before the payment date, and pays the undisputed amount on or before the payment date, any late payment charge for the disputed amount will not start until 10 working days after the payment date. If the billing dispute is resolved in favor of the customer, no late payment penalty will apply to the disputed amount. In addition, if the customer disputes the billed amount and pays the total amount (i.e., the nondisputed amount and the disputed amount) on or before the payment date and the

ISSUED:
March 30, 2007

Mark D. Harper
Director - State Regulatory
5454 W. 110th Street
Overland Park, Kansas 66211

EFFECTIVE:
April 30, 2007

CANCELLED
April 1, 2017
Missouri Public
Service Commission
JI-2017-0168

Filed
Missouri Public
Service Commission

UNITED TELEPHONE COMPANY
OF MISSOURI

Original Page 52

ACCESS SERVICE

RECEIVED

2. General Regulations (Cont'd)

SEP 17 1992

2.4 Payment Arrangements and Credit Allowances (Cont'd)

SEP 21 1992

2.4.1 Payment of Rates, Charges and Deposits (Cont'd) *Service Commission*

(B) (Cont'd)

(3) (Cont'd)

(b) (Cont'd)

(I) the highest interest rate (in decimal value) which may be levied by law for commercial transactions, compounded daily for the number of days from the payment date to and including the date that the customer actually makes the payment to the Telephone Company, or

(II) 0.000590 per day, compounded daily for the number of days from the payment date to and including the date that the customer actually makes the payment to the Telephone Company.

(c) In the event that a billing dispute concerning any charges billed to the customer by the Telephone Company is resolved in favor of the Telephone Company, any payments withheld pending settlement of the dispute shall be subject to the late payment interest charge set forth in (b) preceding. If the customer disputes the bill on or before the payment date, and pays the undisputed amount on or before the payment date, any late payment charge for the disputed amount will not start until 10 working days after the payment date. If the billing dispute is resolved in favor of the customer, no late payment penalty will apply to the disputed amount. In addition, if the customer disputes the billed amount and pays the total amount (i.e., the nondisputed amount and the disputed amount) on or before the payment date and the

21 1992

ISSUED:
September 17, 1992

BY: John L. Roe
Vice President - Administration
5454 West 110th Street
Overland Park, Kansas 66211

EFFECTIVE:
~~October 17, 1992~~
NOV 7 1992

ACCESS SERVICE

2. General Regulations (Cont'd)

2.4 Payment Arrangements and Credit Allowances (Cont'd)

2.4.1 Payment of Rates, Charges and Deposits (Cont'd)

(B) (Cont'd)

(3) (Cont'd)

(c) (Cont'd)

In addition, if the customer disputes the billed amount and pays the total amount (i.e., the nondisputed amount and the disputed amount) on or before the payment date and the billing dispute is resolved in favor of the customer, the customer will receive a credit for a disputed amount penalty from the Telephone Company if the bill in dispute is not resolved within 10 working days following the payment date or the date the customer furnishes to the Telephone Company documentation to support its claim plus 10 working days, whichever date is the late date. The disputed amount penalty shall be the disputed amount resolved in the customer's favor times a penalty factor. The penalty factor shall be the lesser of:

(M)
|
(M)

(I) the highest interest rate (in decimal value) which may be levied by law for commercial transactions, compounded daily for the number of days from the first date to and including the last date of the period involved, or

(II) 0.000407 per day, compounded daily for the number of days from the first date to and including the last date of the period involved.

(R)

(C) When a payment for Access Service Charges billed under this Tariff is due to the Telephone Company from the customer as set forth in (B)(3) preceding on the same payment date that a Purchase of Accounts Receivable net purchase amount is due to the customer from the Telephone Company as set forth in 8.2.2 following, the telephone Company may, with at least 31 days notice to the customer, net the payment for customer Access Service Charges with the net purchase.

(M) Material moved to this page was previously found on Page 52.

ISSUED:
February 27, 2017

Gary L. Kepley
Director, Regulatory Operations
600 New Century Parkway
New Century, Kansas 66031

EFFECTIVE:
April 1, 2017

ACCESS SERVICE

2. General Regulations (Cont'd)

2.4 Payment Arrangements and Credit Allowances (Cont'd)

2.4.1 Payment of Rates, Charges and Deposits (Cont'd)

(B) (Cont'd)

(3) (Cont'd)

(c) (Cont'd)

billing dispute is resolved in favor of the customer, the customer will receive a credit for a disputed amount penalty from the Telephone Company if the bill in dispute is not resolved within 10 working days following the payment date or the date the customer furnishes to the Telephone Company documentation to support its claim plus 10 working days, whichever date is the late date. The disputed amount penalty shall be the disputed amount resolved in the customer's favor times a penalty factor. The penalty factor shall be the lesser of:

(I) the highest interest rate (in decimal value) which may be levied by law for commercial transactions, compounded daily for the number of days from the first date to and including the last date of the period involved, or

(II) 0.000590 per day, compounded daily for the number of days from the first date to and including the last date of the period involved.

(C) When a payment for Access Service Charges billed under this Tariff is due to the Telephone Company from the customer as set forth in (B)(3) preceding on the same payment date that a Purchase of Accounts Receivable net purchase amount is due to the customer from the Telephone Company as set forth in 8.2.2 following, the telephone Company may, with at least 31 days notice to the customer, net the payment for customer Access Service Charges with the net purchase.

ISSUED:
March 30, 2007

Mark D. Harper
Director - State Regulatory
5454 W. 110th Street
Overland Park, Kansas 66211

EFFECTIVE:
April 30, 2007

CANCELLED
April 1, 2017
Missouri Public
Service Commission
JI-2017-0168

Filed
Missouri Public
Service Commission

UNITED TELEPHONE COMPANY
OF MISSOURI

Original Page 53

ACCESS SERVICE

RECEIVED

SEP 17 1992

2. General Regulations (Cont'd)

2.4 Payment Arrangements and Credit Allowances (Cont'd)

2.4.1 Payment of Rates, Charges and Deposits (Cont'd)

(B) (Cont'd)

(3) (Cont'd)

(c) (Cont'd)

billing dispute is resolved in favor of the customer, the customer will receive a credit for a disputed amount penalty from the Telephone Company if the bill in dispute is not resolved within 10 working days following the payment date or the date the customer furnishes to the Telephone Company documentation to support its claim plus 10 working days, whichever date is the late date. The disputed amount penalty shall be the disputed amount resolved in the customer's favor times a penalty factor. The penalty factor shall be the lesser of:

(I) the highest interest rate (in decimal value) which may be levied by law for commercial transactions, compounded daily for the number of days from the first date to and including the last date of the period involved, or

(II) 0.000590 per day, compounded daily for the number of days from the first date to and including the last date of the period involved.

(C) When a payment for Access Service Charges billed under this Tariff is due to the Telephone Company from the customer as set forth in (B)(3) preceding on the same payment date that a Purchase of Accounts Receivable net purchase amount is due to the customer from the Telephone Company as set forth in 8.2.2 following, the telephone Company may, with at least 31 days notice to the customer, net the payment for customer Access Service Charges with the net purchase.

ISSUED:
September 17, 1992

BY: John L. Roe
Vice President - Administration
5454 West 110th Street
Overland Park, Kansas 66211

EFFECTIVE:
~~October 1, 1992~~

NOV 7 1992

ACCESS SERVICE

2. General Regulations (Cont'd)

2.4 Payment Arrangements and Credit Allowances (Cont'd)

2.4.1 Payment of Rates, Charges and Deposits (Cont'd)

(C) (Cont'd)

amount. The Telephone Company will pay the net amount to the customer on the payment date when such net amount is due to the customer or require the customer to pay to the Telephone Company the net amount when such net amount is due to the Telephone Company. If either party does not make the payment on the payment date, a late payment penalty as set forth in 8.2.2(C)(2) following or (B)(3) preceding, whichever is appropriate, applies.

(D) Adjustments for the quantities of services established or discontinued in any billing period beyond the minimum period set forth for services in other sections of this tariff will be prorated to the number of days or major fraction of days based on a 30 day month. The Telephone Company will, upon request and if available, furnish such detailed information as may reasonably be required for verification of any bill.

(E) When a rate as set forth in this tariff is shown to more than two decimal places, the charges will be determined using the rate shown. The resulting amount will then be rounded to the nearest penny (i.e., rounded to two decimal places).

(F) When more than one copy of a customer bill for services provided under the provisions of this tariff is furnished to the customer, an additional charge applies for each additional copy of the bill as set forth in 13.3.6 following.

2.4.2 Minimum Period

The minimum period for which services are provided and for which rates and charges are applicable is one month except for those services set forth in 5.2.5(B) and (C), 7.4.4, 8.1.5(B), 8.3.5(A), 9.4(A) and 13.3.5(C)(1)(b), (c) and (d) following.

ISSUED:
March 30, 2007

Mark D. Harper
Director - State Regulatory
5454 W. 110th Street
Overland Park, Kansas 66211

EFFECTIVE:
April 30, 2007

UNITED TELEPHONE COMPANY
OF MISSOURI

Original Page 54

ACCESS SERVICE

RECEIVED

SEP 27 1992

2. General Regulations (Cont'd)2.4 Payment Arrangements and Credit Allowances (Cont'd)

NOTE: This is a
Public Commission Decision

2.4.1 Payment of Rates, Charges and Deposits (Cont'd)

(C) (Cont'd)

amount. The Telephone Company will pay the net amount to the customer on the payment date when such net amount is due to the customer or require the customer to pay to the Telephone Company the net amount when such net amount is due to the Telephone Company. If either party does not make the payment on the payment date, a late payment penalty as set forth in 8.2.2(C)(2) following or (B)(3) preceding, whichever is appropriate, applies.

(D) Adjustments for the quantities of services established or discontinued in any billing period beyond the minimum period set forth for services in other sections of this tariff will be prorated to the number of days or major fraction of days based on a 30 day month. The Telephone Company will, upon request and if available, furnish such detailed information as may reasonably be required for verification of any bill.

(E) When a rate as set forth in this tariff is shown to more than two decimal places, the charges will be determined using the rate shown. The resulting amount will then be rounded to the nearest penny (i.e., rounded to two decimal places).

(F) When more than one copy of a customer bill for services provided under the provisions of this tariff is furnished to the customer, an additional charge applies for each additional copy of the bill as set forth in 13.3.6 following.

2.4.2 Minimum Period

The minimum period for which services are provided and for which rates and charges are applicable is one month except for those services set forth in 5.2.5(B) and (C), 7.4.4, 8.1.5(B), 8.3.5(A), 9.4(A) and 13.3.5(C)(1)(b), (c) and (d) following.

NOV 7 1992

ISSUED:
September 17, 1992

BY: John L. Roe
Vice President - Administration
5454 West 110th Street
Overland Park, Kansas 66211

EFFECTIVE:
~~October 17, 1992~~

NOV 7 1992

Cancelled

April 30, 2007
Missouri Public
Service Commission

ACCESS SERVICE

2. General Regulations (Cont'd)

2.4 Payment Arrangements and Credit Allowances (Cont'd)

2.4.2 Minimum Period (Cont'd)

The minimum period for which service is provided and for which rates and charges are applicable for a Specialized Service or Arrangement provided on an individual case basis, as set forth in 12. following, is one month unless a different minimum period is established with the individual case filing.

When a service is discontinued prior to the expiration of the minimum period, charges are applicable, whether the service is used or not, as follows:

- (A) When a service with a one month minimum period is discontinued prior to the expiration of the minimum period, a one month charge will apply at the rate level in effect at the time service is discontinued.
- (B) When a service with a minimum period greater than one month is discontinued prior to the expiration of the minimum period, the applicable charge will be the lesser of (1) the Telephone Company's total nonrecoverable costs less the net salvage value for the discontinued service or (2) the total monthly charges, at the rate level in effect at the time service is discontinued, for the remainder of the minimum period.
- (C) Notwithstanding minimum period regulations to the contrary, Local Exchange Carriers participating in the Primary Carrier by Toll Center Plan cannot change Primary Carrier/Secondary Carrier points of physical connection without the mutual agreement of both parties, unless ordered by the Commission.

2.4.3 Cancellation of an Order for Service

Provisions for the cancellation of an Access Order for Switched Access or Special Access service are set forth in 5.2.2(B) and 5.2.3 following.

ISSUED:
March 30, 2007

Mark D. Harper
Director - State Regulatory
5454 W. 110th Street
Overland Park, Kansas 66211

EFFECTIVE:
April 30, 2007

CANCELLED - Missouri Public Service Commission - 07/14/2023 - IN-2023-0447 - YI-2024-0001

UNITED TELEPHONE COMPANY
OF MISSOURI

Original Page 55

RECEIVED

SEP 17 1992

ACCESS SERVICE

2. General Regulations (Cont'd)2.4 Payment Arrangements and Credit Allowances (Cont'd)2.4.2 Minimum Period (Cont'd)

The minimum period for which service is provided and for which rates and charges are applicable for a Specialized Service or Arrangement provided on an individual case basis, as set forth in 12. following, is one month unless a different minimum period is established with the individual case filing.

When a service is discontinued prior to the expiration of the minimum period, charges are applicable, whether the service is used or not, as follows:

- (A) When a service with a one month minimum period is discontinued prior to the expiration of the minimum period, a one month charge will apply at the rate level in effect at the time service is discontinued.
- (B) When a service with a minimum period greater than one month is discontinued prior to the expiration of the minimum period, the applicable charge will be the lesser of (1) the Telephone Company's total nonrecoverable costs less the net salvage value for the discontinued service or (2) the total monthly charges, at the rate level in effect at the time service is discontinued, for the remainder of the minimum period.
- (C) Notwithstanding minimum period regulations to the contrary, Local Exchange Carriers participating in the Primary Carrier by Toll Center Plan cannot change Primary Carrier/Secondary Carrier points of physical connection without the mutual agreement of both parties, unless ordered by the Commission.

2.4.3 Cancellation of an Order for Service

Provisions for the cancellation of an Access Order for Switched Access or Special Access service are set forth in 5.2.2(B) and 5.2.3 following.

ISSUED:
September 17, 1992

BY: John L. Roe
Vice President - Administration
5454 West 110th Street
Overland Park, Kansas 66211

EFFECTIVE:
~~October 17, 1992~~

NOV 7 1992

Cancelled

ACCESS SERVICE

2. General Regulations (Cont'd)

2.4 Payment Arrangements and Credit Allowances (Cont'd)

2.4.4 Credit Allowance for Service Interruptions (Cont'd)

(A) General

A service is interrupted when it becomes unusable to the customer because of a failure of a facility component used to furnish service under this tariff or in the event that the protective controls applied by the Telephone Company result in the complete loss of service by the customer as set forth in 6.5.1 following. An interruption period starts when an inoperative service is reported to the Telephone Company, and ends when the service is operative.

(B) When A Credit Allowance Applies

In case of an interruption to any service, allowance for the period of interruption, if not due to the negligence of the customer, shall be as follows:

- (1) For the following services, no credit shall be allowed for an interruption of less than thirty (30) minutes:

(C)

Special Access Services
Switched Access Voice Grade Entrance Facility
Switched Access Voice Grade Direct-Trunked Transport

The customer shall be credited for an interruption of thirty minutes or more at the rate of 1/1,440 of the monthly charges for the facility or service for each period of thirty minutes or major fraction thereof that the interruption continues.

(C)

The monthly charges used to determine the credit shall be as follows:

- (a) For two-point services, the monthly charge shall be the total of all the monthly rate element charges associated with the service (i.e., service termination(s), channel mileage, optional features and functions, and, when applicable, surcharge for Special Access Service).

(C)

(C)

CANCELLED - Missouri Public Service Commission - 07/14/2023 - IN-2023-0447 - YI-2024-0001

ISSUED:
May 1, 2012

Gary Kepley
Director - Regulatory Operations
5454 W. 110th Street
Overland Park, Kansas 66211

FILED
Missouri Public
Service Commission
TT-2012-0317, YI-2012-0635

EFFECTIVE:
July 3, 2012

ACCESS SERVICE

2. General Regulations (Cont'd)

2.4 Payment Arrangements and Credit Allowances (Cont'd)

2.4.4 Credit Allowance for Service Interruptions (Cont'd)

(A) General

A service is interrupted when it becomes unusable to the customer because of a failure of a facility component used to furnish service under this tariff or in the event that the protective controls applied by the Telephone Company result in the complete loss of service by the customer as set forth in 6.5.1 following. An interruption period starts when an inoperative service is reported to the Telephone Company, and ends when the service is operative.

(B) When A Credit Allowance Applies

In case of an interruption to any service, allowance for the period of interruption, if not due to the negligence of the customer, shall be as follows:

- (1) For Special Access, no credit shall be allowed for an interruption of less than 30 minutes. The customer shall be credited for an interruption of 30 minutes or more at the rate of 1/1440 of the monthly charges for the facility or service for each period of 30 minutes or major fraction thereof that the interruption continues.

The monthly charges used to determine the credit shall be as follows:

- (a) For two-point services, the monthly charge shall be the total of all the monthly rate element charges associated with the service (i.e., two channel terminations, channel mileage and optional features and functions).

ISSUED:
March 30, 2007

Mark D. Harper
Director - State Regulatory
5454 W. 110th Street
Overland Park, Kansas 66211

EFFECTIVE:
April 30, 2007

CANCELED
July 1, 2012
Missouri Public
Service Commission
TT-2012-0317, YI-2012-0635

Filed
Missouri Public
Service Commission

SPRINT MISSOURI, INC.
d/b/a SPRINT

First Revised Page 56
Cancels Original Page 56

ACCESS SERVICE

Missouri Public

2. General Regulations (Cont'd)

REC'D JUL 02 2002

2.4 Payment Arrangements and Credit Allowances (Cont'd)

2.4.4 Credit Allowance for Service Interruptions (Cont'd)

Service Commission

(A) General

A service is interrupted when it becomes unusable to the customer because of a failure of a facility component used to furnish service under this tariff or in the event that the protective controls applied by the Telephone Company result in the complete loss of service by the customer as set forth in 6.5.1 following. An interruption period starts when an inoperative service is reported to the Telephone Company, and ends when the service is operative.

(B) When A Credit Allowance Applies

In case of an interruption to any service, allowance for the period of interruption, if not due to the negligence of the customer, shall be as follows:

- (1) For Special **Access**, **no** credit shall be allowed for an interruption of less than 30 minutes. The customer shall be credited for an interruption of 30 minutes or more at the rate of 1/1440 of the monthly charges for the facility or service for each period of 30 minutes or major fraction thereof that the interruption continues.

(D)

The monthly charges used to determine the credit shall be as follows:

- (a) For two-point services, the monthly charge shall be the total of all the monthly rate element charges associated with the service (i.e., two channel terminations, channel mileage and optional features and functions).

Missouri Public

FILED AUG 12 2002

Service Commission

ISSUED:
July 2, 2002

Richard D. Lawson
State Executive, External Affairs
319 Madison
Jefferson City, MO 65101

~~EFFECTIVE:~~

AUG 12 2002

Cancelled

April 30, 2007
Missouri Public
Service Commission

ACCESS SERVICE

2. General Regulations (Cont'd)

2.4 Payment Arrangements and Credit Allowances (Cont'd)

2.4.4 Credit Allowance for Service Interruptions (Cont'd)

(B) When A Credit Allowance Applies (Cont'd)

(1) (Cont'd)

- (b) For multipoint services, the monthly charge shall be the total of all the monthly rate element charges associated with that portion of the service that is inoperative (i.e., a channel between the Hub and a termination per customer premises, channel mileage and optional features and functions).
- (c) For multiplexed services, the monthly charge shall be the total of all the monthly rate element charges associated with that portion of the service that is inoperative. When the facility which is multiplexed or the multiplexer itself is inoperative, the monthly charge shall be the total of all the monthly rate element charges associated with the service (i.e., channel termination, channel mileages and optional features and functions including the multiplexer on the facility to the Hub and the channel terminations, channel mileages and optional features and functions on the individual services from the Hub). When the service which rides a channel of the multiplexed facility is inoperative, the monthly charge shall be the total of all the monthly rate element charges associated with that portion of the service from the Hub to a customer premises (i.e., channel termination, channel mileage and optional features and functions.)

ISSUED:
March 30, 2007

Mark D. Harper
Director - State Regulatory
5454 W. 110th Street
Overland Park, Kansas 66211

EFFECTIVE:
April 30, 2007

CANCELLED - Missouri Public Service Commission - 07/14/2023 - IN-2023-0447 - YI-2024-0001

UNITED TELEPHONE COMPANY
OF MISSOURI

Original Page 57

RECEIVED

SEP 17 1992

ACCESS SERVICE

2. General Regulations (Cont'd)

2.4 Payment Arrangements and Credit Allowances (Cont'd)

2.4.4 Credit Allowance for Service Interruptions (Cont'd)

(B) When A Credit Allowance Applies (Cont'd)

(1) (Cont'd)

(b) For multipoint services, the monthly charge shall be the total of all the monthly rate element charges associated with that portion of the service that is inoperative (i.e., a channel between the Hub and a termination per customer premises, channel mileage and optional features and functions).

(c) For multiplexed services, the monthly charge shall be the total of all the monthly rate element charges associated with that portion of the service that is inoperative. When the facility which is multiplexed or the multiplexer itself is inoperative, the monthly charge shall be the total of all the monthly rate element charges associated with the service (i.e., channel termination, channel mileages and optional features and functions including the multiplexer on the facility to the Hub and the channel terminations, channel mileages and optional features and functions on the individual services from the Hub). When the service which rides a channel of the multiplexed facility is inoperative, the monthly charge shall be the total of all the monthly rate element charges associated with that portion of the service from the Hub to a customer premises (i.e., channel termination, channel mileage and optional features and functions.)

SEP 17 1992

ISSUED:
September 17, 1992

BY: John L. Roe
Vice President - Administration
5454 West 110th Street
Overland Park, Kansas 66211

EFFECTIVE:
~~September 17, 1992~~
NOV 7 1992

ACCESS SERVICE

2. General Regulations (Cont'd)

2.4 Payment Arrangements and Credit Allowances (Cont'd)

2.4.4 Credit Allowance for Service Interruptions (Cont'd)

(B) When A Credit Allowance Applies (Cont'd)

(2) Reserved for Future Use

(C)

(D)

(D)

ISSUED:
May 1, 2012

Gary Kepley
Director - Regulatory Operations
5454 W. 110th Street
Overland Park, Kansas 66211

FILED
Missouri Public
Service Commission
TT-2012-0317, YI-2012-0635

EFFECTIVE:
July 3, 2012

CANCELLED - Missouri Public Service Commission - 07/14/2023 - IN-2023-0447 - YI-2024-0001

ACCESS SERVICE

2. General Regulations (Cont'd)

2.4 Payment Arrangements and Credit Allowances (Cont'd)

2.4.4 Credit Allowance for Service Interruptions (Cont'd)

(B) When A Credit Allowance Applies (Cont'd)

- (2) For Program Audio and Video Special Access Services, no credit shall be allowed for an interruption of less than 30 seconds. The customer shall be credited for an interruption of 30 seconds or more as follows:
- (a) For two-point services, when monthly rates are applicable, the credit shall be at the rate of 1/8640 of the monthly charges for the service for each period of 5 minutes or major fraction thereof that the interruption continues.
 - (b) For two-point services, when daily rates are applicable, the credit shall be at the rate of 1/288 of the daily charges for the service for each period of 5 minutes or major fraction thereof that the interruption continues.
 - (c) For multipoint services, when monthly rates are applicable, the credit shall be at the rate of 1/8640 of the monthly charges for all Channel Terminations, Channel Mileages and optional features and functions that are inoperative for each period of 5 minutes or major fraction thereof that the interruption continues.
 - (d) For multipoint services, when daily rates are applicable, the credit shall be at the daily rate of 1/288 of the daily charges for all channel terminations, channel mileages and optional features and functions that are inoperative for each period of 5 minutes or major fraction thereof that the interruption continues.

ISSUED:
March 30, 2007

Mark D. Harper
Director - State Regulatory
5454 W. 110th Street
Overland Park, Kansas 66211

EFFECTIVE:
April 30, 2007

CANCELED
July 1, 2012
Missouri Public
Service Commission
TT-2012-0317, YI-2012-0635

Filed
Missouri Public
Service Commission

SPRINT MISSOURI, INC.
d/b/a SPRINT

First Revised Page 58
Cancels Original Page 58

Missouri Public
Service Commission

ACCESS SERVICE

REC'D FEB 09 2000

2. General Regulations (Cont'd)

2.4 Payment Arrangements and Credit Allowances (Cont'd)

2.4.4 Credit Allowance for Service Interruptions (Cont'd)

(B) When A Credit Allowance Applies (Cont'd)

(2) For Program Audio and Video Special Access Services, no credit shall be allowed for an interruption of less than 30 seconds. The customer shall be credited for an interruption of 30 seconds or more as follows:

(a) For two-point services, when monthly rates are applicable, the credit shall be at the rate of 1/8640 of the monthly charges for the service for each period of 5 minutes or major fraction thereof that the interruption continues.

(b) For two-point services, when daily rates are applicable, the credit shall be at the rate of 1/288 of the daily charges for the service for each period of 5 minutes or major fraction thereof that the interruption continues.

(c) For multipoint services, when monthly rates are applicable, the credit shall be at the rate of 1/8640 of the monthly charges for all Channel Terminations, Channel Mileages and optional features and functions that are inoperative for each period of 5 minutes or major fraction thereof that the interruption continues. (T)

(d) For multipoint services, when daily rates are applicable, the credit shall be at the daily rate of 1/288 of the daily charges for all channel terminations, channel mileages and optional features and functions that are inoperative for each period of 5 minutes or major fraction thereof that the interruption continues.

Missouri Public
Service Commission

FILED MAR 10 2000

ISSUED:
February 9, 2000

Richard D. Lawson
State Executive, External Affairs

EFFECTIVE:
March 10, 2000

Cancelled

April 30, 2007
Missouri Public
Service Commission

UNITED TELEPHONE COMPANY
OF MISSOURI

Original Page 58

RECEIVED

SEP 17 1992

ACCESS SERVICE

2. General Regulations (Cont'd)

2.4 Payment Arrangements and Credit Allowances (Cont'd)

MISSOURI

PUBLIC SERVICE COMMISSION

2.4.4 Credit Allowance for Service Interruptions (Cont'd)

(B) When A Credit Allowance Applies (Cont'd)

- (2) For Program Audio and Video Special Access Services, no credit shall be allowed for an interruption of less than 30 seconds. The customer shall be credited for an interruption of 30 seconds or more as follows:
 - (a) For two-point services, when monthly rates are applicable, the credit shall be at the rate of 1/8640 of the monthly charges for the service for each period of 5 minutes or major fraction thereof that the interruption continues.
 - (b) For two-point services, when daily rates are applicable, the credit shall be at the rate of 1/288 of the daily charges for the service for each period of 5 minutes or major fraction thereof that the interruption continues.
 - (c) For multipoint services, when monthly rates are applicable, the credit shall be at the rate of 1/8640 of the monthly charges for all Service Terminations, Channel Mileages and optional features and functions that are inoperative for each period of 5 minutes or major fraction thereof that the interruption continues.
 - (d) For multipoint services, when daily rates are applicable, the credit shall be at the daily rate of 1/288 of the daily charges for all channel terminations, channel mileages and optional features and functions that are inoperative for each period of 5 minutes or major fraction thereof that the interruption continues.

CANCELLED

MAR 10 2000

By *1st R P 58*
Public Service Commission
MISSOURI

FILED

NOV 7 1992

M.O. PUBLIC SERVICE COMMISSION

ISSUED:
September 17, 1992

BY: John L. Roe
Vice President - Administration
5454 West 110th Street
Overland Park, Kansas 66211

EFFECTIVE:
~~October 27, 1992~~
NOV 7 1992

ACCESS SERVICE

2. General Regulations (Cont'd)

2.4 Payment Arrangements and Credit Allowances (Cont'd)

2.4.4 Credit Allowance for Service Interruptions (Cont'd)

(B) When A Credit Allowance Applies (Cont'd)

(2) (Cont'd)

(e) For multipoint services, the credit for the monthly or daily charges includes the charges for the distribution amplifier only when the distribution amplifier is inoperative.

(f) When two or more interruptions occur during a period of 5 consecutive minutes, such multiple interruptions shall be considered as one interruption.

(3) For Switched Access Service (excluding Entrance Facilities and Direct-Trunked Transport) and Directory Assistance Service, no credit shall be allowed for an interruption of less than 24 hours. The customer shall be credited for an interruption of 24 hours or more at the rate of 1/30 of (a) the applicable monthly rates or (b) the assumed minutes of use charge for each period of 24 hours or major fraction thereof that the interruption continues. (C)
(C)

(4) The credit allowance(s) for an interruption or for a series of interruptions shall not exceed the applicable monthly rate or assumed minutes of use charge for the service interrupted in any one monthly billing period. (C)
(C)

(5) For certain Special Access services (Digital Data, DA1-4 and High Capacity, HC1 Services), any period during which the error performance is below that specified for the service will be considered as an interruption.

CANCELLED - Missouri Public Service Commission - 07/14/2023 - IN-2023-0447 - YI-2024-0001

ISSUED:
May 1, 2012

Gary Kepley
Director - Regulatory Operations
5454 W. 110th Street
Overland Park, Kansas 66211

FILED
Missouri Public Service Commission
EFFECTIVE:
July 3, 2012
TT-2012-0317, YI-2012-0635

ACCESS SERVICE

2. General Regulations (Cont'd)

2.4 Payment Arrangements and Credit Allowances (Cont'd)

2.4.4 Credit Allowance for Service Interruptions (Cont'd)

(B) When A Credit Allowance Applies (Cont'd)

(2) (Cont'd)

- (e) For multipoint services, the credit for the monthly or daily charges includes the charges for the distribution amplifier only when the distribution amplifier is inoperative.
- (f) When two or more interruptions occur during a period of 5 consecutive minutes, such multiple interruptions shall be considered as one interruption.
- (3) For Switched Access Service and Directory Assistance Service, no credit shall be allowed for an interruption of less than 24 hours. The customer shall be credited for an interruption of 24 hours or more at the rate of 1/30 of (a) the applicable monthly rates or (b) the assumed minutes of use charge for each period of 24 hours or major fraction thereof that the interruption continues.
- (4) The credit allowance(s) for an interruption or for a series of interruptions shall not exceed the applicable monthly rate or for the service interrupted in any one monthly billing period.
- (5) For certain Special Access services (Digital Data, DA1-4 and High Capacity, HC1 Services), any period during which the error performance is below that specified for the service will be considered as an interruption.

ISSUED:
March 30, 2007

Mark D. Harper
Director - State Regulatory
5454 W. 110th Street
Overland Park, Kansas 66211

EFFECTIVE:
April 30, 2007

CANCELED
July 1, 2012
Missouri Public
Service Commission
TT-2012-0317, YI-2012-0635

Filed
Missouri Public
Service Commission

SPRINT MISSOURI, INC.
d/b/a SPRINT

Second Revised Page 59
Cancels First Revised Page 59

ACCESS SERVICE

Missouri Public

REC'D JAN 07 2002

2. General Regulations (Cont'd)

Service Commission

2.4 Payment Arrangements and Credit Allowances (Cont'd)

2.4.4 Credit Allowance for Service Interruptions (Cont'd)

(B) When A Credit Allowance Applies (Cont'd)

(2) (Cont'd)

(e) For multipoint services, the credit for the monthly or daily charges includes the charges for the distribution amplifier only when the distribution amplifier is inoperative.

(f) When two or more interruptions occur during a period of 5 consecutive minutes, such multiple interruptions shall be considered as one interruption.

(3) For Switched Access Service and Directory Assistance Service, no credit shall be allowed for an interruption of less than 24 hours. The customer shall be credited for an interruption of 24 hours or more at the rate of 1/30 of (a) the applicable monthly rates or (b) the assumed minutes of use **charge for** each period of 24 hours or major fraction thereof that the interruption continues.

(C)

(D)

(D)

(4) The credit allowance(s) for an interruption or for a series of interruptions shall not exceed **the applicable** monthly **rate** or **for** the service interrupted in any one monthly billing period.

(T)

(5) For certain Special Access services (Digital Data, DA1-4 and High Capacity, HC1 Services), any period during which the error performance is below that specified for the service will be considered as an interruption.

Missouri Public

FILED FEB 07 2002

Service Commission

ISSUED:
January 7, 2002

Richard D. Lawson
State Executive, External Affairs
319 Madison
Jefferson City, MO 65101

EFFECTIVE:
February 7, 2002

Cancelled
April 30, 2007
Missouri Public
Service Commission

SPRINT MISSOURI, INC.
d/b/a SPRINT

First Revised Page 59
Cancels Original Page 59

ACCESS SERVICE

Missouri Public
Service Commission

2. General Regulations (Cont'd)

REC'D SEP 10 1999

2.4 Payment Arrangements and Credit Allowances (Cont'd)

2.4.4 Credit Allowance for Service Interruptions (Cont'd)

(B) When A Credit Allowance Applies (Cont'd)

(2) (Cont'd)

(e) For multipoint services, the credit for the monthly or daily charges includes the charges for the distribution amplifier only when the distribution amplifier is inoperative.

(f) When two or more interruptions occur during a period of 5 consecutive minutes, such multiple interruptions shall be considered as one interruption.

(3) For Switched Access Service and Directory Assistance Service, no credit shall be allowed for an interruption of less than 24 hours. The customer shall be credited for an interruption of 24 hours or more at the rate of 1/30 of (a) the applicable monthly rates or (b) the assumed minutes of use charge or (c) the minimum monthly usage charge for each period of 24 hours or major fraction thereof that the interruption continues. However, in no case is a credit allowance applicable when the actual usage charge exceeds the minimum monthly usage charge in any one monthly billing period.

(4) The credit allowance(s) for an interruption or for a series of interruptions shall not exceed (a) applicable monthly rate or (b) the minimum monthly usage charges for the service interrupted in any one monthly billing period.

(5) For certain Special Access services (Digital Data, DAL-4 and High Capacity, HCl Services), any period during which the error performance is below that specified for the service will be considered as an interruption. (T) (T)

CANCELLED

FEB 07 2002

2nd RP 59

Public Service Commission
MISSOURI

Missouri Public
Service Commission

FILED OCT 15 1999
EFFECTIVE

ISSUED:
September 10, 1999

Richard D. Lawson
State Executive, External Affairs

OCT 15 1999

UNITED TELEPHONE COMPANY
OF MISSOURI

Original Page 59

ACCESS SERVICE

RECEIVED

SEP 17 1992

2. General Regulations (Cont'd)

2.4 Payment Arrangements and Credit Allowances (Cont'd)

MISSOURI

2.4.4 Credit Allowance for Service Interruptions (Cont'd)

Public Service Commission

(B) When A Credit Allowance Applies (Cont'd)

(2) (Cont'd)

(e) For multipoint services, the credit for the monthly or daily charges includes the charges for the distribution amplifier only when the distribution amplifier is inoperative.

(f) When two or more interruptions occur during a period of 5 consecutive minutes, such multiple interruptions shall be considered as one interruption.

(3) For Switched Access Service and Directory Assistance Service, no credit shall be allowed for an interruption of less than 24 hours. The customer shall be credited for an interruption of 24 hours or more at the rate of 1/30 of (a) the applicable monthly rates or (b) the assumed minutes of use charge or (c) the minimum monthly usage charge for each period of 24 hours or major fraction thereof that the interruption continues. However, in no case is a credit allowance applicable when the actual usage charge exceeds the minimum monthly usage charge in any one monthly billing period.

CANCELLED

OCT 15 1999
Public Service Commission
MISSOURI

(4) The credit allowance(s) for an interruption or for a series of interruptions shall not exceed (a) applicable monthly rate or (b) the minimum monthly usage charges for the service interrupted in any one monthly billing period.

(5) For certain Special Access services (United DigiLink™, DA1-4, United TransLink™, HCl and other High Capacity Services), any period during which the error performance is below that specified for the service will be considered as an interruption.

NOV 7 1992

* A Service Mark of United Telecommunications, Inc.,

NOV 7 1992

ISSUED:
September 17, 1992

BY: John L. Roe
Vice President - Administration
5454 West 110th Street
Overland Park, Kansas 66211

EFFECTIVE:
~~October 17, 1992~~
NOV 7 1992

ACCESS SERVICE

2. General Regulations (Cont'd)

2.4 Payment Arrangements and Credit Allowances (Cont'd)

2.4.4 Credit Allowance for Service Interruptions (Cont'd)

(B) When A Credit Allowance Applies (Cont'd)

- (6) Service interruptions for Specialized Service or Arrangements provided under the provisions of 12. following shall be administered in the same manner as those set forth in this section (2.4.4) unless other regulations are specified with the individual case filing.

(C) When a Credit Allowance Does Not Apply

No credit allowance will be made for:

- (1) Interruptions caused by the negligence of the customer.
- (2) Interruptions of a service due to the failure of equipment or systems provided by the customer or others.
- (3) Interruptions of a service during any period in which the Telephone Company is not afforded access to the premises where the service is terminated.
- (4) Interruptions of a service when the customer has released that service to the Telephone Company for maintenance purposes, to make rearrangements, or for the implementation of an order for a change in the service during the time that was negotiated with the customer prior to the release of the service. There after, a credit allowance as set forth in (B) preceding applies.

ISSUED:
March 30, 2007

Mark D. Harper
Director - State Regulatory
5454 W. 110th Street
Overland Park, Kansas 66211

EFFECTIVE:
April 30, 2007

CANCELLED - Missouri Public Service Commission - 07/14/2023 - IN-2023-0447 - YI-2024-0001

UNITED TELEPHONE COMPANY
OF MISSOURI

Original Page 60

ACCESS SERVICE

RECEIVED

2. General Regulations (Cont'd)

SEP 17 1992

2.4 Payment Arrangements and Credit Allowances (Cont'd)

MISSOURI

2.4.4 Credit Allowance for Service Interruptions (Cont'd)

FILED SEP 13 1992

(B) When A Credit Allowance Applies (Cont'd)

- (6) Service interruptions for Specialized Service or Arrangements provided under the provisions of 12. following shall be administered in the same manner as those set forth in this section (2.4.4) unless other regulations are specified with the individual case filing.

(C) When a Credit Allowance Does Not Apply

No credit allowance will be made for:

- (1) Interruptions caused by the negligence of the customer.
- (2) Interruptions of a service due to the failure of equipment or systems provided by the customer or others.
- (3) Interruptions of a service during any period in which the Telephone Company is not afforded access to the premises where the service is terminated.
- (4) Interruptions of a service when the customer has released that service to the Telephone Company for maintenance purposes, to make rearrangements, or for the implementation of an order for a change in the service during the time that was negotiated with the customer prior to the release of the service. There after, a credit allowance as set forth in (B) preceding applies.

ISSUED:
September 17, 1992

BY: John L. Roe
Vice President - Administration
5454 West 110th Street
Overland Park, Kansas 66211

EFFECTIVE:
~~October 17, 1992~~
NOV 7 1992

ACCESS SERVICE

2. General Regulations (Cont'd)

2.4 Payment Arrangements and Credit Allowances (Cont'd)

2.4.4 Credit Allowance for Service Interruptions (Cont'd)

(C) When a Credit Allowance Does Not Apply (Cont'd)

- (5) Interruptions of a service which continue because of the failure of the customer to authorize replacement of any element of special construction, as set forth in Section 14, Special Construction, of this tariff. The period for which no credit allowance is made begins on the seventh day after the customer receives the Telephone Company's written notification of the need for such replacement and ends on the day after receipt by the Telephone Company of the customer's written authorization for such replacement.
- (6) Periods when the customer elects not to release the service for testing and/or repair and continues to use it on an impaired basis.
- (7) Periods of temporary discontinuance as set forth in 2.2.2 (B) preceding.
- (8) Periods of interruption as set forth in 13.3.1 following.
- (9) An interruption or a group of interruptions, resulting from a common cause, for amounts less than one dollar.
- (10) During a declared national emergency, where priority installation of National Security Emergency Preparedness (NSEP) telecommunications services shall take precedence.
- (11) During natural disasters, work stoppages, civil disturbances, criminal actions; or by fire, flooding or other occurrences attributed to an Act of God, or other causes beyond the Telephone Company's reasonable control. (C)
(C)
- (12) If a planned or scheduled outage for maintenance, upgrades and enhancements take place.
- (13) Interruptions of a service due to the failure of facilities or equipment provided by connecting carriers. (N)
(N)

CANCELLED - Missouri Public Service Commission - 07/14/2023 - IN-2023-0447 - YI-2024-0001

ISSUED:
May 1, 2012

Gary L. Kepley
Director - Regulatory Operations
5454 W. 110th Street
Overland Park, Kansas 66211

FILED
Missouri Public
Service Commission
EFFECTIVE:
July 3, 2012
TT-2012-0317, YI-2012-0635

ACCESS SERVICE

2. General Regulations (Cont'd)

2.4 Payment Arrangements and Credit Allowances (Cont'd)

2.4.4 Credit Allowance for Service Interruptions (Cont'd)

(C) When a Credit Allowance Does Not Apply (Cont'd)

- (5) Interruptions of a service which continue because of the failure of the customer to authorize replacement of any element of special construction, as set forth in Section 14, Special Construction, of this tariff. The period for which no credit allowance is made begins on the seventh day after the customer receives the Telephone Company's written notification of the need for such replacement and ends on the day after receipt by the Telephone Company of the customer's written authorization for such replacement.
- (6) Periods when the customer elects not to release the service for testing and/or repair and continues to use it on an impaired basis.
- (7) Periods of temporary discontinuance as set forth in 2.2.2 (B) preceding.
- (8) Periods of interruption as set forth in 13.3.1 following.
- (9) An interruption or a group of interruptions, resulting from a common cause, for amounts less than one dollar.
- (10) During a declared national emergency, where priority installation of National Security Emergency Preparedness (NSEP) telecommunications services shall take precedence.
- (11) During natural disasters, work stoppages, civil disturbances, criminal actions; or by fire, flooding or other occurrences attributed to an Act of God.
- (12) If a planned or scheduled outage for maintenance, upgrades and enhancements take place.

ISSUED:
March 30, 2007

Mark D. Harper
Director - State Regulatory
5454 W. 110th Street
Overland Park, Kansas 66211

EFFECTIVE:
April 30, 2007

CANCELED
July 1, 2012
Missouri Public
Service Commission
TT-2012-0317, YI-2012-0635

Filed
Missouri Public
Service Commission

SPRINT MISSOURI, INC.
d/b/a SPRINT

First Revised Page 61
Cancels Original Page 61
**Missouri Public
Service Commission**

ACCESS SERVICE

REC'D NOV 29 2000

2. General Regulations (Cont'd)

2.4 Payment Arrangements and Credit Allowances (Cont'd)

2.4.4 Credit Allowance for Service Interruptions (Cont'd)

(C) When a Credit Allowance Does Not Apply (Cont'd)

- (5) Interruptions of a service which continue because of the failure of the customer to authorize replacement of any element of special construction, as set forth in Section 14, Special Construction, of this tariff. The period for which no credit allowance is made begins on the seventh day after the customer receives the Telephone Company's written notification of the need for such replacement and ends on the day after receipt by the Telephone Company of the customer's written authorization for such replacement.
- (6) Periods when the customer elects not to release the service for testing and/or repair and continues to use it on an impaired basis.
- (7) Periods of temporary discontinuance as set forth in 2.2.2 (B) preceding.
- (8) Periods of interruption as set forth in 13.3.1 following.
- (9) An interruption or a group of interruptions, resulting from a common cause, for amounts less than one dollar.
- (10) *During a declared national emergency, where priority installation of National Security Emergency Preparedness (NSEP) telecommunications services shall take precedence.* (N)
- (11) *During natural disasters, work stoppages, civil disturbances, criminal actions; or by fire, flooding or other occurrences attributed to an Act of God.*
- (12) *If a planned or scheduled outage for maintenance, upgrades and enhancements take place.* (N)

ISSUED:
November 29, 2000

Richard D. Lawson
State Executive, External Affairs
319 Madison
Jefferson City, MO 65101

EFFECTIVE:
December 29, 2000

**Missouri Public
Service Commission**

FILED DEC 29 2000

UNITED TELEPHONE COMPANY
OF MISSOURI

Original Page 61

ACCESS SERVICE

RECEIVED

2. General Regulations (Cont'd)

SEP 17 1992

2.4 Payment Arrangements and Credit Allowances (Cont'd) MISSOURI

Public Service Commission

2.4.4 Credit Allowance for Service Interruptions (Cont'd)

(C) When a Credit Allowance Does Not Apply (Cont'd)

- (5) Interruptions of a service which continue because of the failure of the customer to authorize replacement of any element of special construction, as set forth in Section 14, Special Construction, of this tariff. The period for which no credit allowance is made begins on the seventh day after the customer receives the Telephone Company's written notification of the need for such replacement and ends on the day after receipt by the Telephone Company of the customer's written authorization for such replacement.
- (6) Periods when the customer elects not to release the service for testing and/or repair and continues to use it on an impaired basis.
- (7) Periods of temporary discontinuance as set forth in 2.2.2 (B) preceding.
- (8) Periods of interruption as set forth in 13.3.1 following.
- (9) An interruption or a group of interruptions, resulting from a common cause, for amounts less than one dollar.

CANCELLED

DEC 29 2000

By 1st RP61
Public Service Commission
MISSOURI

FILED

NOV 7 1992

R.O. FULTON

ISSUED:
September 17, 1992

BY: John L. Roe
Vice President - Administration
5454 West 110th Street
Overland Park, Kansas 66211

EFFECTIVE:
~~October 1, 1992~~
NOV 7 1992

ACCESS SERVICE

2. General Regulations (Cont'd)

2.4 Payment Arrangements and Credit Allowances (Cont'd)

2.4.4 Credit Allowance for Service Interruptions (Cont'd)

(D) Use of an Alternative Service Provided by the Telephone Company

Should the customer elect to use an alternative service provided by the Telephone Company during the period that a service is interrupted, the customer must pay the tariffed rates and charges for the alternative service used.

(E) Temporary Surrender of a Service

In certain instances, the customer may be requested by the Telephone Company to surrender a service for purposes other than maintenance, testing or activity relating to a service order. If the customer consents, a credit allowance will be granted. The credit allowance will be 1/1440 of the monthly rate for each period of 30 minutes or fraction thereof that the service is surrendered. In no case will the credit allowance exceed the monthly rate for the service surrendered in any one monthly billing period.

2.4.5 Reserved For Future Use

ISSUED:
March 30, 2007

Mark D. Harper
Director - State Regulatory
5454 W. 110th Street
Overland Park, Kansas 66211

EFFECTIVE:
April 30, 2007

CANCELLED - Missouri Public Service Commission - 07/14/2023 - IN-2023-0447 - YI-2024-0001

UNITED TELEPHONE COMPANY
OF MISSOURI

Original Page 62
RECEIVED
SEP 17 1992

ACCESS SERVICE

2. General Regulations (Cont'd)

2.4 Payment Arrangements and Credit Allowances (Cont'd)

2.4.4 Credit Allowance for Service Interruptions (Cont'd)

(D) Use of an Alternative Service Provided by the Telephone Company

Should the customer elect to use an alternative service provided by the Telephone Company during the period that a service is interrupted, the customer must pay the tariffed rates and charges for the alternative service used.

(E) Temporary Surrender of a Service

In certain instances, the customer may be requested by the Telephone Company to surrender a service for purposes other than maintenance, testing or activity relating to a service order. If the customer consents, a credit allowance will be granted. The credit allowance will be 1/1440 of the monthly rate for each period of 30 minutes or fraction thereof that the service is surrendered. In no case will the credit allowance exceed the monthly rate for the service surrendered in any one monthly billing period.

2.4.5 Reserved For Future Use

SEP 17 1992

ISSUED:
September 17, 1992

BY: John L. Roe
Vice President - Administration
5454 West 110th Street
Overland Park, Kansas 66211

EFFECTIVE:
~~October 1, 1992~~
NOV 7 1992

ACCESS SERVICE

2. General Regulations (Cont'd)

2.4 Payment Arrangements and Credit Allowances (Cont'd)

2.4.6 Reestablishment of Service Following Fire, Flood or Other Occurrence

(A) Nonrecurring Charges Do Not Apply

Charges do not apply for the reestablishment of service following a fire, flood or other occurrence attributed to an Act of God provided that:

- (1) The service is of the same type as was provided prior to the fire, flood and other occurrence.
- (2) The service is for the same customer.
- (3) The service is at the same location on the same premises.
- (4) The reestablishment of service begins within 60 days after Telephone Company service is available. (The 60 day period may be extended a reasonable period if the renovation of the original location on the premises affected is not practical within the allotted time period.)

(B) Nonrecurring Charges Apply

Nonrecurring Charges apply for establishing service at a different location on the same premises or at a different premises pending reestablishment of service at the original location.

2.4.7 Title or Ownership Rights

- (A) The payment of rates and charges by customers for the services offered under the provisions of this tariff does not assign, confer or transfer title or ownership rights to proposals or facilities developed or utilized, respectively, by the Telephone Company in the provision of such services.

ISSUED:
March 30, 2007

Mark D. Harper
Director - State Regulatory
5454 W. 110th Street
Overland Park, Kansas 66211

EFFECTIVE:
April 30, 2007

CANCELLED - Missouri Public Service Commission - 07/14/2023 - IN-2023-0447 - YI-2024-0001

UNITED TELEPHONE COMPANY
OF MISSOURI

Original Page 63
RECEIVED
SEP 17 1992

ACCESS SERVICE

2. General Regulations (Cont'd)

2.4 Payment Arrangements and Credit Allowances (Cont'd)

2.4.6 Reestablishment of Service Following Fire, Flood or Other Occurrence

(A) Nonrecurring Charges Do Not Apply

Charges do not apply for the reestablishment of service following a fire, flood or other occurrence attributed to an Act of God provided that:

- (1) The service is of the same type as was provided prior to the fire, flood and other occurrence.
- (2) The service is for the same customer.
- (3) The service is at the same location on the same premises.
- (4) The reestablishment of service begins within 60 days after Telephone Company service is available. (The 60 day period may be extended a reasonable period if the renovation of the original location on the premises affected is not practical within the allotted time period.)

(B) Nonrecurring Charges Apply

Nonrecurring Charges apply for establishing service at a different location on the same premises or at a different premises pending reestablishment of service at the original location.

2.4.7 Title or Ownership Rights

- (A) The payment of rates and charges by customers for the services offered under the provisions of this tariff does not assign, confer or transfer title or ownership rights to proposals or facilities developed or utilized, respectively, by the Telephone Company in the provision of such services.

ISSUED:
September 17, 1992

BY: John L. Roe
Vice President - Administration
5454 West 110th Street
Overland Park, Kansas 66211

EFFECTIVE:
~~October 1, 1992~~
NOV 7 1992

ACCESS SERVICE

2. General Regulations (Cont'd)

2.4 Payment Arrangements and Credit Allowances (Cont'd)

2.4.8 Ordering, Rating and Billing of Access Services Where More Than One Exchange Telephone Company or Rate Schedule is Involved

The Telephone Company will handle ordering, rating and billing of Access Services under this tariff where more than one Exchange Telephone company or rate schedule is involved in the provision of Access Service as set forth in (A) or (B) following. The choice of either (A) or (B) shall be made by the Telephone Company and the Telephone Company will notify the customer which option will apply when the customer orders Access Service. The choice of (A) or (B) will be based on the interconnection arrangements between the Exchange Telephone companies involved. The option set forth in (A) following is transitional only and will expire with December 31, 1987.

- (A) When an Access Service is ordered by a customer where one end of the Transport element (i.e., Switched Access Service Local Transport, Directory Transport or Special Access Service Channel Mileage.) is in one Exchange Telephone Company operating territory and the other end is in another Exchange Telephone company operating territory, except for Access Services provided with the use of Hubs, the Exchange Telephone company in whose operating territory the customer's end user is located will accept the order for the Access Service from the customer except for Switched Access Services ordered on a per line or per trunk basis. The Exchange Telephone in whose territory the first point of switching is located will accept the order for Feature Group A,B and D Switched Access Services ordered in lines or trunks. The Exchange Telephone Company that accepts the order will then determine the charges involved, arrange to provide the Access Service ordered and bill the charges in accordance with its Access Service tariff.

ISSUED:
March 30, 2007

Mark D. Harper
Director - State Regulatory
5454 W. 110th Street
Overland Park, Kansas 66211

EFFECTIVE:
April 30, 2007

CANCELLED - Missouri Public Service Commission - 07/14/2023 - IN-2023-0447 - YI-2024-0001

UNITED TELEPHONE COMPANY
OF MISSOURI

Original Page 64

RECEIVED

SEP 17 1992

ACCESS SERVICE

2. General Regulations (Cont'd)

2.4 Payment Arrangements and Credit Allowances (Cont'd)

2.4.8 Ordering, Rating and Billing of Access Services Where More Than One Exchange Telephone Company or Rate Schedule is Involved

The Telephone Company will handle ordering, rating and billing of Access Services under this tariff where more than one Exchange Telephone company or rate schedule is involved in the provision of Access Service as set forth in (A) or (B) following. The choice of either (A) or (B) shall be made by the Telephone Company and the Telephone Company will notify the customer which option will apply when the customer orders Access Service. The choice of (A) or (B) will be based on the interconnection arrangements between the Exchange Telephone companies involved. The option set forth in (A) following is transitional only and will expire with December 31, 1987.

- (A) When an Access Service is ordered by a customer where one end of the Transport element (i.e., Switched Access Service Local Transport, Directory Transport or Special Access Service Channel Mileage.) is in one Exchange Telephone Company operating territory and the other end is in another Exchange Telephone company operating territory, except for Access Services provided with the use of Hubs, the Exchange Telephone company in whose operating territory the customer's end user is located will accept the order for the Access Service from the customer except for Switched Access Services ordered on a per line or per trunk basis. The Exchange Telephone in whose territory the first point of switching is located will accept the order for Feature Group A, B and D Switched Access Services ordered in lines or trunks. The Exchange Telephone Company that accepts the order will then determine the charges involved, arrange to provide the Access Service ordered and bill the charges in accordance with its Access Service tariff.

ISSUED:
September 17, 1992

BY: John L. Roe
Vice President - Administration
5454 West 110th Street
Overland Park, Kansas 66211

EFFECTIVE:
~~October 1, 1992~~
NOV 7 1992

Cancelled
April 30, 2007
Missouri Public
Service Commission

ACCESS SERVICE

2. General Regulations (Cont'd)

2.4 Payment Arrangements and Credit Allowances (Cont'd)

2.4.8 Ordering, Rating and Billing of Access Services Where More Than One Exchange Telephone Company or Rate Schedule is Involved (Cont'd)

When an Access Service provided with the use of a Hub is ordered by a customer, the Exchange Telephone Company in whose territory the Hub is located will accept the order for the Access Service from the customer. That Exchange Telephone Company will then determine the charges involved, arrange to provide the Access Service ordered and bill the charges in accordance with its Access Service tariff.

In accordance with the Federal Communications Commission's Memorandum Opinion and Order in CC Docket No. 86-106, adopted July 20, 1987, the Telephone Company will adhere to the standards set forth in the Multiple Exchange Carrier Access Billing (MECAB) and the Multiple Exchange Carrier Ordering and Design (MECOD) Guidelines when providing access service under Multiple Company (Interconnection Point) Billing arrangements. These documents are available for customer inspection as set forth in the Reference to Other Publications Section of this tariff.

(N)
|
(N)

(B) The Telephone Company will handle ordering, rating and billing of Access Services under this tariff where more than one Exchange Telephone Company or rate schedule is involved in the provision of Access Service as follows:

(1) When Feature Group A and or B Switched Access Service is ordered by a customer where one end of the Transport element is in one Exchange Telephone Company operating territory and the other end is in another Exchange Telephone Company operating territory, the Exchange Telephone Company in whose territory the first point of switching is located will accept the order. In addition, the Exchange Telephone Company in whose territory the customer point of termination is located must also receive a copy of the order from the customer. The Exchange Telephone Company that accepts the order will then determine the charges involved, arrange to provide the Access Service ordered and bill the charges in accordance with its Access Service tariff.

(2) When Feature Group C, and/or D Switched Access Service and/or Directory Assistance Service is ordered by a customer where one end of the Transport element is in the Telephone Company operating territory and the other end is in another Exchange Telephone Company operating territory, the orders shall be received as follows:

MO2021-05

ISSUED:
April 30, 2021

Chantel Bosworth
Director – Government Operations
100 CenturyLink Drive
Monroe, LA 71203

EFFECTIVE:
May 30, 2021

FILED
Missouri Public
Service Commission
JI-2021-0191

CANCELLED - Missouri Public Service Commission - 07/14/2023 - IN-2023-0447 - YI-2024-0001

ACCESS SERVICE

2. General Regulations (Cont'd)

2.4 Payment Arrangements and Credit Allowances (Cont'd)

2.4.8 Ordering, Rating and Billing of Access Services Where More Than One Exchange Telephone Company or Rate Schedule is Involved (Cont'd)

When an Access Service provided with the use of a Hub is ordered by a customer, the Exchange Telephone Company in whose territory the Hub is located will accept the order for the Access Service from the customer. That Exchange Telephone Company will then determine the charges involved, arrange to provide the Access Service ordered and bill the charges in accordance with its Access Service tariff.

(B) The Telephone Company will handle ordering, rating and billing of Access Services under this tariff where more than one Exchange Telephone Company or rate schedule is involved in the provision of Access Service as follows:

- (1) When Feature Group A and or B Switched Access Service is ordered by a customer where one end of the Transport element is in one Exchange Telephone Company operating territory and the other end is in another Exchange Telephone Company operating territory, the Exchange Telephone Company in whose territory the first point of switching is located will accept the order. In addition, the Exchange Telephone Company in whose territory the customer point of termination is located must also receive a copy of the order from the customer. The Exchange Telephone Company that accepts the order will then determine the charges involved, arrange to provide the Access Service ordered and bill the charges in accordance with its Access Service tariff.
- (2) When Feature Group C, and/or D Switched Access Service and/or Directory Assistance Service is ordered by a customer where one end of the Transport element is in the Telephone Company operating territory and the other end is in another Exchange Telephone Company operating territory, the orders shall be received as follows:

ISSUED:
March 30, 2007

Mark D. Harper
Director - State Regulatory
5454 W. 110th Street
Overland Park, Kansas 66211

EFFECTIVE:
April 30, 2007

CANCELLED
May 30, 2021
Missouri Public
Service Commission
JI-2021-0191

Filed
Missouri Public
Service Commission

UNITED TELEPHONE COMPANY
OF MISSOURI

Original Page 65

RECEIVED

SEP 17 1992

ACCESS SERVICE

2. General Regulations (Cont'd)2.4 Payment Arrangements and Credit Allowances (Cont'd)

2.4.8 Ordering, Rating and Billing of Access Services Where More Than
One Exchange Telephone Company or Rate Schedule is Involved
(Cont'd)

When an Access Service provided with the use of a Hub is ordered by a customer, the Exchange Telephone Company in whose territory the Hub is located will accept the order for the Access Service from the customer. That Exchange Telephone Company will then determine the charges involved, arrange to provide the Access Service ordered and bill the charges in accordance with its Access Service tariff.

(B) The Telephone Company will handle ordering, rating and billing of Access Services under this tariff where more than one Exchange Telephone Company or rate schedule is involved in the provision of Access Service as follows:

- (1) When Feature Group A and or B Switched Access Service is ordered by a customer where one end of the Transport element is in one Exchange Telephone Company operating territory and the other end is in another Exchange Telephone Company operating territory, the Exchange Telephone Company in whose territory the first point of switching is located will accept the order. In addition, the Exchange Telephone Company in whose territory the customer point of termination is located must also receive a copy of the order from the customer. The Exchange Telephone Company that accepts the order will then determine the charges involved, arrange to provide the Access Service ordered and bill the charges in accordance with its Access Service tariff.
- (2) When Feature Group C, and/or D Switched Access Service and/or Directory Assistance Service is ordered by a customer where one end of the Transport element is in the Telephone Company operating territory and the other end is in another Exchange Telephone Company operating territory, the orders shall be received as follows:

ISSUED:
September 17, 1992

BY: John L. Roe
Vice President - Administration
5454 West 110th Street
Overland Park, Kansas 66211

EFFECTIVE:

~~October 1, 1992~~
NOV 7 1992

Cancelled

ACCESS SERVICE

2. General Regulations (Cont'd)

2.4 Payment Arrangements and Credit Allowances (Cont'd)

2.4.8 Ordering, Rating and Billing of Access Services Where More Than One Exchange Telephone Company or Rate Schedule is Involved (Cont'd)

(B) (2) (Cont'd)

- (a) For Feature Group C Switched Access Service and/or Directory Assistance Service, the Exchange Telephone Company in whose operating territory the end office is located must receive the order from the customer.
- (b) For Feature Group D Switched Access Service ordered to an end office, the Exchange Telephone Company in whose operating territory the end office is located must receive the order from the customer.
- (c) For Feature Group D Switched Access Service ordered to an access tandem, the Exchange Telephone Company in whose territory the access tandem is located must receive the order from the customer.
- (d) For the Service ordered set forth in (a), (b) and (c) preceding, the Exchange Telephone Company in whose territory the customer point of termination is located must also receive a copy of the order from the customer.
- (e) **Single Bill Method: The Exchange Telephone Companies involved will mutually agree upon a "billing company" which will render the bill for the Access Service provided. The designated billing company will perform the "Access Service Coordination" (ASC) function for the service requested, determine the applicable charges, and bill the customer for the entire service in accordance with the applicable Access Service tariff(s). The designated billing company will be billed by the other Exchange Telephone Companies involved for the portion of the Access Service they provide. Available options for the Single Bill option are:**

- 1. Single Bill/Single Tariff
- 2. Single Bill/Multiple Tariff

(N)

(N)

(M) – Material moved to Page 66.1
MO2021-05

ISSUED:
April 30, 2021

Chantel Bosworth
Director – Government Operations
100 CenturyLink Drive
Monroe, LA 71203

EFFECTIVE:
May 30, 2021

FILED
Missouri Public
Service Commission
JI-2021-0191

CANCELLED - Missouri Public Service Commission - 07/14/2023 - IN-2023-0447 - YI-2024-0001

ACCESS SERVICE

2. General Regulations (Cont'd)

2.4 Payment Arrangements and Credit Allowances (Cont'd)

2.4.8 Ordering, Rating and Billing of Access Services Where More Than One Exchange Telephone Company or Rate Schedule is Involved (Cont'd)

(B) (2) (Cont'd)

- (a) For Feature Group C Switched Access Service and/or Directory Assistance Service, the Exchange Telephone Company in whose operating territory the end office is located must receive the order from the customer.
- (b) For Feature Group D Switched Access Service ordered to an end office, the Exchange Telephone Company in whose operating territory the end office is located must receive the order from the customer.
- (c) For Feature Group D Switched Access Service ordered to an access tandem, the Exchange Telephone Company in whose territory the access tandem is located must receive the order from the customer.
- (d) For the Service ordered set forth in (a), (b) and (c) preceding, the Exchange Telephone Company in whose territory the customer point of termination is located must also receive a copy of the order from the customer.

Each Exchange Telephone Company will provide the portion of the Transport element in its operating territory to an interconnection point with another Exchange Telephone Company and will bill the charges in accordance with its Access Service tariff. The rate for the Transport element will be determined as set forth in (8) following. All other appropriate charges in each Exchange Telephone Company tariff are applicable.

ISSUED:
March 30, 2007

Mark D. Harper
Director - State Regulatory
5454 W. 110th Street
Overland Park, Kansas 66211

EFFECTIVE:
April 30, 2007

CANCELLED
May 30, 2021
Missouri Public
Service Commission
JI-2021-0191

Filed
Missouri Public
Service Commission

UNITED TELEPHONE COMPANY
OF MISSOURI

Original Page 66

ACCESS SERVICE

RECEIVED

SEP 17 1992

2. General Regulations (Cont'd)2.4 Payment Arrangements and Credit Allowances (Cont'd)

2.4.8 Ordering, Rating and Billing of Access Services Where More Than
One Exchange Telephone Company or Rate Schedule is Involved
(Cont'd)

(B) (2) (Cont'd)

- (a) For Feature Group C Switched Access Service and/or Directory Assistance Service, the Exchange Telephone Company in whose operating territory the end office is located must receive the order from the customer.
- (b) For Feature Group D Switched Access Service ordered to an end office, the Exchange Telephone Company in whose operating territory the end office is located must receive the order from the customer.
- (c) For Feature Group D Switched Access Service ordered to an access tandem, the Exchange Telephone Company in whose territory the access tandem is located must receive the order from the customer.
- (d) For the Service ordered set forth in (a), (b) and (c) preceding, the Exchange Telephone Company in whose territory the customer point of termination is located must also receive a copy of the order from the customer.

Each Exchange Telephone Company will provide the portion of the Transport element in its operating territory to an interconnection point with another Exchange Telephone Company and will bill the charges in accordance with its Access Service tariff. The rate for the Transport element will be determined as set forth in (8) following. All other appropriate charges in each Exchange Telephone Company tariff are applicable.

ISSUED:
September 17, 1992

BY: John L. Roe
Vice President - Administration
5454 West 110th Street
Overland Park, Kansas 66211

EFFECTIVE:

~~October 17, 1992~~
NOV 7 1992

Cancelled

ACCESS SERVICE

2. General Regulations (Cont'd)

2.4 Payment Arrangements and Credit Allowances (Cont'd)

2.4.8 Ordering, Rating and Billing of Access Services Where More Than One Exchange Telephone Company or Rate Schedule is Involved (Cont'd)

(B) (2) (Cont'd)

(f) **Multiple Bill Method: Each Exchange Telephone Company involved will provide the portion of the service in its operating territory and bill the customer in accordance with its Access Service tariff.**

(N)

(N)

Each Exchange Telephone Company will provide the portion of the Transport element in its operating territory to an interconnection point with another Exchange Telephone Company and will bill the charges in accordance with its Access Service tariff. The rate for the Transport element will be determined as set forth in (8) following. All other appropriate charges in each Exchange Telephone Company tariff are applicable.

(M)

(M)

(M) – Material moved from Page 66.
MO2021-05

ISSUED:
April 30, 2021

Chantel Bosworth
Director – Government Operations
100 CenturyLink Drive
Monroe, LA 71203

EFFECTIVE:
May 30, 2021

ACCESS SERVICE

2. General Regulations (Cont'd)

2.4 Payment Arrangements and Credit Allowances (Cont'd)

2.4.8 Ordering, Rating and Billing of Access Services Where More Than One Exchange Telephone Company or Rate Schedule is Involved (Cont'd)

(B) (Cont'd)

- (3) When a WATS Access Line Service ordered and channel mileage usage applies (i.e., the WATS serving office and the end user customer end office are not coterminous) and one end of the channel mileage element is in the Telephone Company operating territory and the other end is in another Exchange Telephone Company operating territory, the Exchange Telephone Company in whose operating territory the end office is located must receive the order from the customer. In addition, the Exchange Telephone Company in whose operating territory the WATS Serving Office is located must also receive a copy of the order from the customer. Each Exchange Telephone Company will provide the portion of the channel mileage element in its operating territory to an interconnection point with another Exchange Telephone Company and will bill the charges in accordance with its Access Service tariff. The rate for the channel mileage element will be determined as set forth in (8) following. All other appropriate charges in each Exchange Telephone Company tariff are applicable.
- (4) When a Special Access Service is ordered by a customer where one end of the Channel Mileage is in the Telephone Company operating territory and the other end is in another Exchange Telephone Company operating territory, except for Special Access Service provided with the use of Hubs, either of the Exchange Telephone Companies may receive the order from the customer. In addition, the other Exchange Telephone Company must receive a copy of the order from the customer. Each Exchange Telephone Company will provide the portion of the Channel Mileage element in its operating territory

ISSUED:
March 30, 2007

Mark D. Harper
Director - State Regulatory
5454 W. 110th Street
Overland Park, Kansas 66211

EFFECTIVE:
April 30, 2007

CANCELLED - Missouri Public Service Commission - 07/14/2023 - IN-2023-0447 - YI-2024-0001

UNITED TELEPHONE COMPANY
OF MISSOURI

Original Page 67

RECEIVED

ACCESS SERVICE

SEP 17 1992

2. General Regulations (Cont'd)

2.4 Payment Arrangements and Credit Allowances (Cont'd)

2.4.8 Ordering, Rating and Billing of Access Services Where More Than One Exchange Telephone Company or Rate Schedule is Involved
(Cont'd)

(B) (Cont'd)

- (3) When a WATS Access Line Service ordered and channel mileage usage applies (i.e., the WATS serving office and the end user customer end office are not coterminous) and one end of the channel mileage element is in the Telephone Company operating territory and the other end is in another Exchange Telephone Company operating territory, the Exchange Telephone Company in whose operating territory the end office is located must receive the order from the customer. In addition, the Exchange Telephone Company in whose operating territory the WATS Serving Office is located must also receive a copy of the order from the customer. Each Exchange Telephone Company will provide the portion of the channel mileage element in its operating territory to an interconnection point with another Exchange Telephone Company and will bill the charges in accordance with its Access Service tariff. The rate for the channel mileage element will be determined as set forth in (8) following. All other appropriate charges in each Exchange Telephone Company tariff are applicable.
- (4) When a Special Access Service is ordered by a customer where one end of the Channel Mileage is in the Telephone Company operating territory and the other end is in another Exchange Telephone Company operating territory, except for Special Access Service provided with the use of Hubs, either of the Exchange Telephone Companies may receive the order from the customer. In addition, the other Exchange Telephone Company must receive a copy of the order from the customer. Each Exchange Telephone Company will provide the portion of the Channel Mileage element in its operating territory

ISSUED:
September 17, 1992

BY: John L. Roe
Vice President - Administration
5454 West 110th Street
Overland Park, Kansas 66211

EFFECTIVE:
~~October 6, 1992~~

NOV 7 1992

ACCESS SERVICE

2. General Regulations (Cont'd)

2.4 Payment Arrangements and Credit Allowances (Cont'd)

2.4.8 Ordering, Rating and Billing of Access Services Where More Than One Exchange Telephone Company or Rate Schedule is Involved (Cont'd)

(B) (4) (Cont'd)

to an interconnection point (IP) with another Exchange Telephone Company and will bill the charges in accordance with its Access Service tariff. The rate for the Channel Mileage element will be determined as set forth in (8) following. All other appropriate charges in each Exchange Telephone Company tariff are applicable.

(5) When a Special Access Service involving a Hub is ordered by a customer where one end of the Channel Mileage element is in an Exchange Telephone Company operating territory and the Hub is in another Exchange Telephone Company operating territory, the Exchange Telephone Company in whose territory the Hub is located must receive the order from the customer. In addition, The Exchange Telephone Company in whose operating territory a customer premises is located must receive copies of the order from the customer. Each Exchange Telephone Company will provide the portion of the Channel Mileage element in its operating territory to an interconnection point (IP) with another Exchange Telephone Company and will bill the charges in accordance with its Access Service Tariff. The rate for the Channel Mileage element will be determined as set forth in (8) following. All other appropriate charges in each Exchange Telephone Company tariff are applicable.

(6) When a Feature Group A, B, C and/or D Switched Access Service is ordered by a customer where both ends or an end and an interconnection point of the Transport Element are in the same Telephone Company and same exchange but in different states which have

ISSUED:
March 30, 2007

Mark D. Harper
Director - State Regulatory
5454 W. 110th Street
Overland Park, Kansas 66211

EFFECTIVE:
April 30, 2007

CANCELLED - Missouri Public Service Commission - 07/14/2023 - IN-2023-0447 - YI-2024-0001

UNITED TELEPHONE COMPANY
OF MISSOURI

Original Page 68

RECEIVED

SEP 17 1992

ACCESS SERVICE

2. General Regulations (Cont'd)

2.4 Payment Arrangements and Credit Allowances (Cont'd)

MISSOURI
Public Service Commission

2.4.8 Ordering, Rating and Billing of Access Services Where More Than One Exchange Telephone Company or Rate Schedule is Involved
(Cont'd)

(B) (4) (Cont'd)

to an interconnection point (IP) with another Exchange Telephone Company and will bill the charges in accordance with its Access Service tariff. The rate for the Channel Mileage element will be determined as set forth in (8) following. All other appropriate charges in each Exchange Telephone Company tariff are applicable.

- (5) When a Special Access Service involving a Hub is ordered by a customer where one end of the Channel Mileage element is in an Exchange Telephone Company operating territory and the Hub is in another Exchange Telephone Company operating territory, the Exchange Telephone Company in whose territory the Hub is located must receive the order from the customer. In addition, The Exchange Telephone Company in whose operating territory a customer premises is located must receive copies of the order from the customer. Each Exchange Telephone Company will provide the portion of the Channel Mileage element in its operating territory to an interconnection point (IP) with another Exchange Telephone Company and will bill the charges in accordance with its Access Service Tariff. The rate for the Channel Mileage element will be determined as set forth in (8) following. All other appropriate charges in each Exchange Telephone Company tariff are applicable.
- (6) When a Feature Group A, B, C and/or D Switched Access Service is ordered by a customer where both ends or an end and an interconnection point of the Transport Element are in the same Telephone Company and same exchange but in different states which have

SEP 17 1992

ISSUED:
September 17, 1992

BY: John L. Roe
Vice President - Administration
5454 West 110th Street
Overland Park, Kansas 66211

EFFECTIVE:
~~October 17, 1992~~
NOV 7 1992

ACCESS SERVICE

2. General Regulations (Cont'd)

2.4 Payment Arrangements and Credit Allowances (Cont'd)

2.4.8 Ordering, Rating and Billing of Access Services Where More Than One Exchange Telephone Company or Rate Schedule is Involved (Cont'd)

(B) (6) (Cont'd)

different rate schedules, the Telephone Company will accept the order in the state where the first point of switching is located. When a WATS Access Line Service is ordered and a channel mileage element applies and both ends or one end and an interconnection point of the channel mileage element are in the same Tele-phon e Company and same exchange but in different states which have different rate schedules, the Telephone Company will accept the order in the state where the WATS Serving Office is located. The Telephone Company will provide the service ordered and will bill the portion of the service in each state in accordance with the rate schedule for that state. An inter-connection point will be determined by the Telephone Company and will be used to determine the billing for each state. The rate for the Transport element will be determined as set forth in (8) following.

(7) When a Special Access Service, including those involving a Hub, but excluding those ordered as WATS Access Line Service, is ordered by a customer where both ends of the Channel Mileage element, an end of the Channel Mileage element and an interconnection point, an end of the Channel Mileage element and a Hub or inter-connection point and a Hub are in the same Telephone Company and the same exchange but in different states which have different rate schedules, the Exchange Telephone Company will accept the order in either state except for orders involving Hubs. For orders involving Hubs, the order must be placed in the state where the Hub is located. An interconnection point will be determined by the Exchange Telephone Company and will be used to determine the billing for each state. All appropriate charges in each state rate schedule are applicable. The rate for the Channel Mileage element will be determined as set forth in (8) following.

(M)
(M)

(M) This material previously appeared on Page 70.

ISSUED:
May 1, 2012

Gary L. Kepley
Director - Regulatory Operations
5454 W. 110th Street
Overland Park, Kansas 66211

FILED
Missouri Public
Service Commission
EFFECTIVE:
July 3, 2012
TT-2012-0317, YI-2012-0635

CANCELLED - Missouri Public Service Commission - 07/14/2023 - IN-2023-0447 - YI-2024-0001

ACCESS SERVICE

2. General Regulations (Cont'd)

2.4 Payment Arrangements and Credit Allowances (Cont'd)

2.4.8 Ordering, Rating and Billing of Access Services Where More Than One Exchange Telephone Company or Rate Schedule is Involved (Cont'd)

(B) (6) (Cont'd)

different rate schedules, the Telephone Company will accept the order in the state where the first point of switching is located. When a WATS Access Line Service is ordered and a channel mileage element applies and both ends or one end and an interconnection point of the channel mileage element are in the same Telephone Company and same exchange but in different states which have different rate schedules, the Telephone Company will accept the order in the state where the WATS Serving Office is located. The Telephone Company will provide the service ordered and will bill the portion of the service in each state in accordance with the rate schedule for that state. An inter-connection point will be determined by the Telephone Company and will be used to determine the billing for each state. The rate for the Transport element will be determined as set forth in (8) following.

(7) When a Special Access Service, including those involving a Hub, but excluding those ordered as WATS Access Line Service, is ordered by a customer where both ends of the Channel Mileage element, an end of the Channel Mileage element and an interconnection point, an end of the Channel Mileage element and a Hub or inter-connection point and a Hub are in the same Telephone Company and the same exchange but in different states which have different rate schedules, the Exchange Telephone Company will accept the order in either state except for orders involving Hubs. For orders involving Hubs, the order must be placed in the state where the Hub is located. An interconnection point will be determined by the Exchange Telephone Company and will be used to determine the billing for each state. All appropriate charges in each state rate schedule are applicable. The rate

ISSUED:
March 30, 2007

Mark D. Harper
Director - State Regulatory
5454 W. 110th Street
Overland Park, Kansas 66211

EFFECTIVE:
April 30, 2007

CANCELED
July 1, 2012
Missouri Public
Service Commission
TT-2012-0317, YI-2012-0635

Filed
Missouri Public
Service Commission

UNITED TELEPHONE COMPANY
OF MISSOURI

Original Page 69

ACCESS SERVICE

RECEIVED

SEP 17 1992

2. General Regulations (Cont'd)2.4 Payment Arrangements and Credit Allowances (Cont'd)2.4.8 Ordering, Rating and Billing of Access Services Where More Than One Exchange Telephone Company or Rate Schedule is Involved (Cont'd)

(B) (5) (Cont'd)

different rate schedules, the Telephone Company will accept the order in the state where the first point of switching is located. When a WATS Access Line Service is ordered and a channel mileage element applies and both ends or one end and an interconnection point of the channel mileage element are in the same Telephone Company and same exchange but in different states which have different rate schedules, the Telephone Company will accept the order in the state where the WATS Serving Office is located. The Telephone Company will provide the service ordered and will bill the portion of the service in each state in accordance with the rate schedule for that state. An interconnection point will be determined by the Telephone Company and will be used to determine the billing for each state. The rate for the Transport element will be determined as set forth in (8) following.

- (7) When a Special Access Service, including those involving a Hub, but excluding those ordered as WATS Access Line Service, is ordered by a customer where both ends of the Channel Mileage element, an end of the Channel Mileage element and an interconnection point, an end of the Channel Mileage element and a Hub or interconnection point and a Hub are in the same Telephone Company and the same exchange but in different states which have different rate schedules, the Exchange Telephone Company will accept the order in either state except for orders involving Hubs. For orders involving Hubs, the order must be placed in the state where the Hub is located. An interconnection point will be determined by the Exchange Telephone Company and will be used to determine the billing for each state. All appropriate charges in each state rate schedule are applicable. The rate

ISSUED:
September 17, 1992

BY: John L. Roe
Vice President - Administration
5454 West 110th Street
Overland Park, Kansas 66211

EFFECTIVE:
~~October 17, 1992~~
NOV 7 1992

Cancelled

ACCESS SERVICE

2. General Regulations (Cont'd)

2.4 Payment Arrangements and Credit Allowances (Cont'd)

2.4.8 Ordering, Rating and Billing of Access Services Where More Than One Exchange Telephone Company or Rate Schedule is Involved (Cont'd)

(B) (Cont'd)

(8) When Terminating Tandem Switched Transport is provided through a CenturyLink Operating Company (CLOC) ILEC Access Tandem and the Terminating End Office is not owned by any CLOC ILEC or through an ILEC Access Tandem not owned by a CLOC ILEC and the Terminating End Office is owned by a CLOC ILEC, Terminating – Tandem 3rd Party rates are applicable; otherwise, Terminating – Tandem End Office rates are applicable. When originating Tandem Switched Transport is provided, Originating rates are applicable. The rate for the Switched Access Direct-Trunked Transport and Tandem-Switched Transport or Special Access Channel Mileage per mile element for services provided as set for in (1) through (7) preceding is determined as follows:

(N)
|
(N)

(a) Determine the appropriate Switched Transport or Channel Mileage by computing the airline mileage between the two ends of the Switched Transport or Channel Mileage element. Determine the airline mileage for the Tandem-Switched Transport per mile element using the V & H method as set forth in Section 6.7.14 following. Determine the airline mileage for the Direct-Trunk Transport and Channel Mileage per mile element using the V & H method as set forth in Section 7.4.6 following.

(b) Determine the rate for the airline mileage determined in (a) preceding using the Telephone Company's tariff. Multiply such rate by the Telephone Company's billing percentage factor and divide by 100 to obtain the Switched Transport element or Channel Mileage per mile element charges.

(9) The interconnection points will be determined by the Exchange Telephone Companies involved. The billing percentage factor for the Telephone Company for the service between the two involved offices is listed in National Exchange Carrier Association, Inc. Tariff F.C.C. No. 4 *.

(T)

(*) For intraLATA Local Exchange Carrier to Local Exchange Carrier traffic percentages of ownership will be determined by the V&H coordinates located in the Missouri Intrastate IntraLATA Compensation Plan Database.

(T)

ISSUED:
May 1, 2017

Gary L. Kepley
Director - Regulatory Operations
600 New Century Parkway
New Century, Kansas 66031

EFFECTIVE:
July 1, 2017

FILED
Missouri Public
Service Commission
YI-2017-0229

CANCELLED - Missouri Public Service Commission - 07/14/2023 - IN-2023-0447 - YI-2024-0001

ACCESS SERVICE

2. General Regulations (Cont'd)

2.4 Payment Arrangements and Credit Allowances (Cont'd)

2.4.8 Ordering, Rating and Billing of Access Services Where More Than One Exchange Telephone Company or Rate Schedule is Involved (Cont'd)

(B) (Cont'd)

(M)
(M)

(8) The rate for the Switched Access Direct-Trunked Transport and Tandem-Switched Transport or Special Access Channel Mileage per mile element for services provided as set for in (1) through (7) preceding is determined as follows:

(C)

(a) Determine the appropriate Switched Transport or Channel Mileage by computing the airline mileage between the two ends of the Switched Transport or Channel Mileage element. Determine the airline mileage for the Tandem-Switched Transport per mile element using the V & H method as set forth in Section 6.7.14 following. Determine the airline mileage for the Direct-Trunk Transport and Channel Mileage per mile element using the V & H method as set forth in Section 7.4.6 following.

(C)

(b) Determine the rate for the airline mileage determined in (a) preceding using the Telephone Company's tariff. Multiply such rate by the Telephone Company's billing percentage factor and divide by 100 to obtain the Switched Transport element or Channel Mileage per mile element charges.

(C)

(9) The interconnection points will be determined by the Exchange Telephone Companies involved. The billing percentage factor for the Telephone Company for the service between the two involved offices is listed in National Exchange Carrier Association, Inc. Tariff F.C.C. No. 4.

(1) For intraLATA Local Exchange Carrier to Local Exchange Carrier traffic percentages of ownership will be determined by the V&H coordinates located in the Missouri Intrastate IntraLATA Compensation Plan Database.

(M) Material omitted from this page now appears on Page 69.

ISSUED:
CANCELED May 1, 2012

July 1, 2017
Missouri Public
Service Commission
YI-2017-0229

Gary L. Kepley
Director - Regulatory Operations
5454 W. 110th Street
Overland Park, Kansas 66211

FILED EFFECTIVE:
Missouri Public July 3, 2012
Service Commission
TT-2012-0317, YI-2012-0635

ACCESS SERVICE

2. General Regulations (Cont'd)

2.4 Payment Arrangements and Credit Allowances (Cont'd)

2.4.8 Ordering, Rating and Billing of Access Services Where More Than One Exchange Telephone Company or Rate Schedule is Involved (Cont'd)

(B) (7) (Cont'd)

for the Channel Mileage element will be determined as set forth in (8) following.

(8) The rate for the Transport or Channel Mileage per mile element for services provided as set forth in (2) through (7) preceding is determined in as follows:

(a) Determine the appropriate Transport or Channel Mileage by computing the airline mileage between the two ends of the Transport or Channel Mileage element. Determine the airline mileage for the Transport element using the V & H (1) method as set forth in 6.7.13 following. Determine the airline mileage for the Channel Mileage element using the V & H (1) method as set forth in 7.4.6 following.

(b) Determine the rate for the airline mileage determined in (a) preceding using the Telephone Company's tariff. Multiply such rate by the Telephone Company's billing percentage factor and divide by 100 to obtain the Transport element or Channel Mileage per mile element charges.

(9) The interconnection points will be determined by the Exchange Telephone Companies involved. The billing percentage factor for the Telephone Company for the service between the two involved offices is listed in National Exchange Carrier Association, Inc. Tariff F.C.C. No. 4.

(1) For intraLATA Local Exchange Carrier to Local Exchange Carrier traffic percentages of ownership will be determined by the V&H coordinates located in the Missouri Intrastate IntraLATA Compensation Plan Database.

ISSUED:
March 30, 2007

Mark D. Harper
Director - State Regulatory
5454 W. 110th Street
Overland Park, Kansas 66211

EFFECTIVE:
April 30, 2007

CANCELED
July 1, 2012
Missouri Public
Service Commission
TT-2012-0317, YI-2012-0635

Filed
Missouri Public
Service Commission

SPRINT MISSOURI, INC.
d/b/a SPRINT

Third Revised Page 70
Cancels Second Revised Page 70
Missouri Public

ACCESS SERVICE

REC'D JAN 07 2002

2. General Regulations (Cont'd)

2.4 Payment Arrangements and Credit Allowances (Cont'd)

Service Commission

2.4.8 Ordering, Rating and Billing of Access Services Where More Than One Exchange Telephone Company or Rate Schedule is Involved (Cont'd)

(B) (7) (Cont'd)

for the Channel Mileage element will be determined as set forth in (8) following.

(8) The rate for the Transport or Channel Mileage per mile element for services provided as set forth in (2) through (7) preceding is determined in as follows:

(a) Determine the appropriate Transport or Channel Mileage by computing the airline mileage between the two ends of the Transport or Channel Mileage element. Determine the airline mileage for the Transport element using the V & H (1) method as set forth in 6.7.13 following. Determine the airline mileage for the Channel Mileage element using the V & H (1) method as set forth in 7.4.6 following.

(b) Determine the rate for the airline mileage determined in (a) preceding using the Telephone Company's tariff. Multiply such rate by the Telephone Company's billing percentage factor and divide by 100 to obtain the Transport element or Channel Mileage per mile element charges.

(9) The interconnection points will be determined by the Exchange Telephone Companies involved. The billing percentage factor for the Telephone Company for the service between the two involved offices is listed in **National Exchange Carrier Association, Inc.** Tariff **F.C.C. No. 4.**

(T)
(T)

(1) For intraLATA Local Exchange Carrier to Local Exchange Carrier traffic percentages of ownership will be determined by the V&H coordinates located in the Missouri Intrastate IntraLATA Compensation Plan Database.

Missouri Public

FILED FEB 07 2002

ISSUED:
January 7, 2002

Richard D. Lawson
State Executive, External Affairs
319 Madison
Jefferson City, MO 65101

Service Commission
EFFECTIVE:
February 7, 2002

SPRINT MISSOURI, INC.
d/b/a SPRINT

Second Revised Page 70
Cancels First Revised Page 70

RECEIVED

ACCESS SERVICE

JAN 26 2001

2. General Regulations (Cont'd)

2.4 Payment Arrangements and Credit Allowances (Cont'd)

**MISSOURI
Public Service Commission**

2.4.8 Ordering, Rating and Billing of Access Services Where More Than One
Exchange Telephone Company or Rate Schedule is Involved (Cont'd)

(B) (7) (Cont'd)

for the Channel Mileage element will be determined as set forth in (8) following.

(8) The rate for the Transport or Channel Mileage per mile element for services provided as set forth in (2) through (7) preceding is determined in as follows:

(a) Determine the appropriate Transport or Channel Mileage by computing the airline mileage between the two ends of the Transport or Channel Mileage element. Determine the airline mileage for the Transport element using the V & H (1) method as set forth in 6.7.13 following. Determine the airline mileage for the Channel Mileage element using the V & H (1) method as set forth in 7.4.6 following.

(b) Determine the rate for the airline mileage determined in (a) preceding using the Telephone Company's tariff. Multiply such rate by the Telephone Company's billing percentage factor and divide by 100 to obtain the Transport element or Channel Mileage per mile element charges.

(9) The interconnection points will be determined by the Exchange Telephone Companies involved. The billing percentage factor for the Telephone Company for the service between the two involved offices is listed in Exchange Carrier Association Tariff.

CANCELLED

FEB 07 2002

By *3MRP70*
**Public Service Commission
MISSOURI**

(1) For intraLATA Local Exchange Carrier to Local Exchange Carrier traffic percentages of ownership will be determined by the V&H coordinates located in the Missouri Intrastate (T) IntraLATA Compensation Plan Database.

ISSUED:
January 26, 2001

Richard D. Lawson
State Executive, External Affairs
319 Madison
Jefferson City, MO 65101

FILED

EFFECTIVE:
February 26, 2001

FEB 26 2001

**MISSOURI
Public Service Commission**

SPRINT MISSOURI, INC.
d/b/a SPRINT

First Revised Page 70
Cancels Original Page 70

**Missouri Public
Service Commission**

ACCESS SERVICE

REC'D FEB 09 2000

2. General Regulations (Cont'd)

2.4 Payment Arrangements and Credit Allowances (Cont'd)

2.4.8 Ordering, Rating and Billing of Access Services Where
More Than One Exchange Telephone Company or Rate Schedule
is Involved (Cont'd)

(B) (7) (Cont'd)

for the Channel Mileage element will be determined as set forth in (8) following.

(8) The rate for the Transport or Channel Mileage per mile element for services provided as set forth in (2) through (7) preceding is determined in as follows:

(a) Determine the appropriate Transport or Channel Mileage by computing the airline mileage between the two ends of the Transport or Channel Mileage element. Determine the airline mileage for the Transport element using the V & H (1) method as set forth in 6.7.13 following. Determine the airline mileage for the Channel Mileage element using the V & H (1) method as set forth in 7.4.6 following.

(b) Determine the rate for the airline mileage determined in (a) preceding using the Telephone Company's tariff. Multiply such rate by the Telephone Company's billing percentage factor and divide by 100 to obtain the Transport element or Channel Mileage per mile element charges.

(9) The interconnection points will be determined by the Exchange Telephone Companies involved. The billing percentage factor for the Telephone Company for the service between the two involved offices is listed in Exchange Carrier Association Tariff.

(1) For intraLATA Local Exchange Carrier to Local Exchange Carrier traffic percentages of ownership will be determined by the V&G coordinates located in the Missouri Intrastate IntraLATA Compensation Plan Database. (T)

CANCELLED

FEB 26 2001

2nd RP 70

**Public Service Commission
MISSOURI**

**Missouri Public
Service Commission**

FILED MAR 10 2000

ISSUED:
February 9, 2000

Richard D. Lawson
State Executive, External Affairs

EFFECTIVE:
March 10, 2000

UNITED TELEPHONE COMPANY
OF MISSOURI

Original Page 70

RECEIVED

ACCESS SERVICE

SEP 17 1992

2. General Regulations (Cont'd)

MISSOURI

2.4 Payment Arrangements and Credit Allowances (Cont'd) **Public Service Commission**

2.4.8 Ordering, Rating and Billing of Access Services Where More Than One Exchange Telephone Company or Rate Schedule is Involved (Cont'd)

(B) (7) (Cont'd)

for the Channel Mileage element will be determined as set forth in (8) following.

(8) The rate for the Transport or Channel Mileage per mile element for services provided as set forth in (2) through (7) preceding is determined in as follows:

(a) Determine the appropriate Transport or Channel Mileage by computing the airline mileage between the two ends of the Transport or Channel Mileage element. Determine the airline mileage for the Transport element using the V & H (1) method as set forth in 6.7.13 following. Determine the airline mileage for the Channel Mileage element using the V & H (1) method as set forth in 7.4.6 following.

(b) Determine the rate for the airline mileage determined in (a) preceding using the Telephone Company's tariff. Multiply such rate by the Telephone Company's billing percentage factor and divide by 100 to obtain the Transport element or Channel Mileage per mile element charges.

(9) The interconnection points will be determined by the Exchange Telephone Companies involved. The billing percentage factor for the Telephone Company for the service between the two involved offices is listed in Exchange Carrier Association Tariff.

(1) For intraLATA Local Exchange Carrier to Local Exchange Carrier traffic percentages of ownership will be determined by the V&G coordinates located in the Missouri PTC Plan IntraLATA Database.

CANCELLED

MAR 10 2000

1st RP 70

Public Service Commission
MISSOURI

FILED

NOV 7 1992

MO. PUBLIC SERVICE COMMISSION

ISSUED:
September 17, 1992

BY: John L. Roe
Vice President - Administration
5454 West 110th Street
Overland Park, Kansas 66211

EFFECTIVE:
~~October 1, 1992~~
NOV 7 1992

ACCESS SERVICE

2. General Regulations (Cont'd)

2.4 Payment Arrangements and Credit Allowances (Cont'd)

2.4.8 Ordering, Rating and Billing of Access Services Where More Than One Exchange Telephone Company or Rate Schedule is Involved (Cont'd)

(B) (Cont'd)

(10) Example 1: Originating Switched Access
(See Diagram 1)

- Feature Group D Switched Access is ordered to End Office.
- Originating End Office and Access Tandem are in the operating territory of a Telephone Company (TC-A).
- Customer Designated Premises is in the operating territory of a Telephone Company (TC-B).
- Assumptions:
 - o TC-A Direct Trunk Transport BP = 40%
 - o TC-B Direct Trunk Transport BP = 60%
 - o Direct Trunked Transport mileage = 26 mi.
 - o Tandem Switched Transport mileage = 23 mi.

Diagram 1

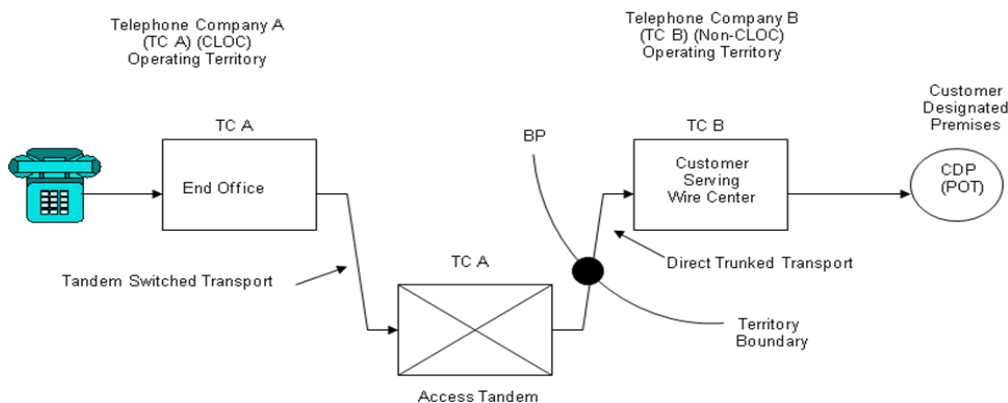

CANCELLED - Missouri Public Service Commission - 07/14/2023 - IN-2023-0447 - YI-2024-0001

(C)

(C)

ISSUED:
May 1, 2017

Gary L. Kepley
Director - Regulatory Operations
600 New Century Parkway
New Century, Kansas 66031

EFFECTIVE:
July 1, 2017

FILED
Missouri Public
Service Commission
YI-2017-0229

ACCESS SERVICE

2. General Regulations (Cont'd)

2.4 Payment Arrangements and Credit Allowances (Cont'd)

2.4.8 Ordering, Rating and Billing of Access Services Where More Than One Exchange Telephone Company or Rate Schedule is Involved (Cont'd)

(B) (Cont'd)

(10) Example - Switched Access

(a) Layout

- (i) Feature Group C Switched Access is ordered to End Office A.
- (ii) End Office A is in operating territory of Exchange Telephone Company A.
- (iii) Premises of ordering Customer is in operating territory of Exchange Telephone Company B.

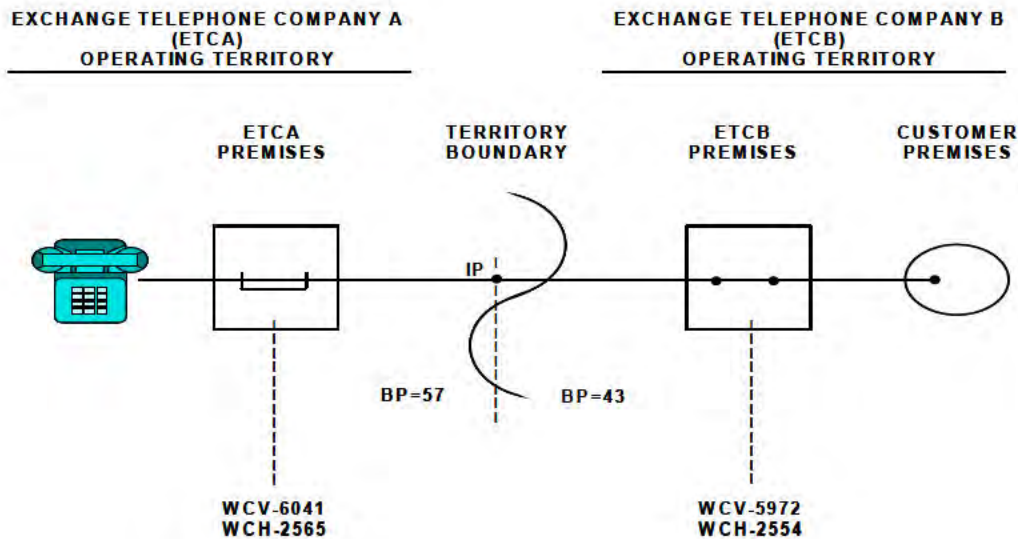

ISSUED:
March 30, 2007

Mark D. Harper
Director - State Regulatory
5454 W. 110th Street
Overland Park, Kansas 66211

EFFECTIVE:
April 30, 2007

UNITED TELEPHONE COMPANY
OF MISSOURI

Original Page 71

ACCESS SERVICE

RECEIVED

SEP 17 1992

2. General Regulations (Cont'd)

2.4 Payment Arrangements and Credit Allowances (Cont'd)

MISSOURI
Public Service Commission

2.4.8 Ordering, Rating and Billing of Access Services Where More Than One Exchange Telephone Company or Rate Schedule is Involved (Cont'd)

(B) (Cont'd)

(10) Example - Switched Access

(a) Layout

- (i) Feature Group C Switched Access is ordered to End Office A.
- (ii) End Office A is in operating territory of Exchange Telephone Company A.
- (iii) Premises of ordering Customer is in operating territory of Exchange Telephone Company B.

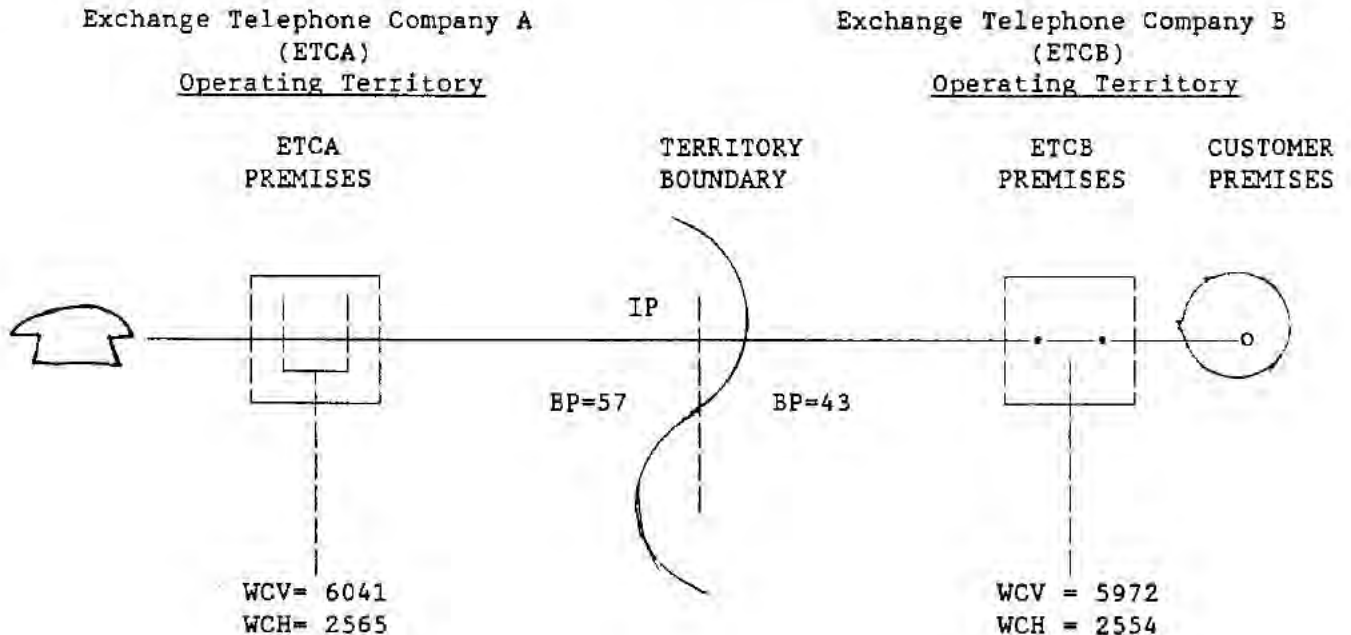

ISSUED:
September 17, 1992

BY: John L. Roe
Vice President - Administration
5454 West 110th Street
Overland Park, Kansas 66211

EFFECTIVE:
~~September 17, 1992~~

NOV 7 1992

ACCESS SERVICE

2. General Regulations (Cont'd)

2.4 Payment Arrangements and Credit Allowances (Cont'd)

2.4.8 Ordering, Rating and Billing of Access Services Where More Than One Exchange Telephone Company or Rate Schedule is Involved (Cont'd)

(B) (Cont'd)

(10) Example 1: Originating Switched Access (Cont'd)
(See Diagram 1)

Telephone Company A charges are:

End Office charges = 9,000 min. x EO rate

Tandem Switched Facility charge
= 9,000 min. x 23 mi. x TSF rate

Tandem Switched Termination charge
= 2 terminations x 9,000 min. x TST rate

Tandem Switching charge
= 9,000 min x TS rate

Direct Trunked Facility charge
= 26 miles x DTF rate x 40%

Direct Trunked Termination charge
= 1 termination x DTT rate

Common Transport Multiplexing charge
= 9,000 min x CTM rate

(C)

(C)

CANCELLED - Missouri Public Service Commission - 07/14/2023 - IN-2023-0447 - YI-2024-0001

ISSUED:
May 1, 2017

Gary L. Kepley
Director - Regulatory Operations
600 New Century Parkway
New Century, Kansas 66031

EFFECTIVE:
July 1, 2017

FILED
Missouri Public
Service Commission
YI-2017-0229

ACCESS SERVICE

2. General Regulations (Cont'd)

2.4 Payment Arrangements and Credit Allowances (Cont'd)

2.4.8 Ordering, Rating and Billing of Access Services Where More Than One Exchange Telephone Company or Rate Schedule is Involved (Cont'd)

(B) (Cont'd)

(10) Example – Switched Access (Cont'd)

(2) Airline Mileages (Using National Exchange Carrier Association Tariff Inc. Tariff F.C.C. No. 4).

- ETCA premises to ETCB premises = 22.1, rounded = 23

(3) Tandem-Switched Transmission charges for 10,220 access minutes

- Assume ETCA rate for Tandem-Switched Transmission is \$0.0001 per access minute per mile
- Assume ETCA Billing Percentage (BP) is 57
- Assume ETCB rate for Tandem-Switched Transmission is \$0.0002 per access minute per mile
- Assume ETCB Billing Percentage (BP) is 43
- Formula:

$$\text{ETCA Tandem-Switched Transmission Per Mile Charge} = \frac{\text{Access Minutes} \times \text{ETCA Rate} \times \text{ETCA Billing}}{100}$$

- Calculation of Transport Charges

$$\text{ETCA Tandem-Switched Transmission Per Mile Charge} = 10220 \times \$0.0001 \times \frac{57}{100} = \$0.583$$

$$\text{ETCB Tandem-Switched Transmission Per Mile Charge} = 10220 \times \$0.0002 \times \frac{43}{100} = \$0.879$$

(C)
|
(C)
|
(C)
(C)
|
(C)

ISSUED:
CANCELED May 1, 2012

July 1, 2017
Missouri Public
Service Commission
YI-2017-0229

Gary L. Kepley
Director - Regulatory Operations
5454 W. 110th Street
Overland Park, Kansas 66211

FILED EFFECTIVE:
Missouri Public July 3, 2012
Service Commission
TT-2012-0317, YI-2012-0635

ACCESS SERVICE

2. General Regulations (Cont'd)

2.4 Payment Arrangements and Credit Allowances (Cont'd)

2.4.8 Ordering, Rating and Billing of Access Services Where More Than One Exchange Telephone Company or Rate Schedule is Involved (Cont'd)

(B) (Cont'd)

(10) Example - Switched Access (Cont'd)

(b) Airline Mileages (Using National Exchange Carrier Association, Inc. Tariff F.C.C. No. 4).

- ETCA premises to ETCB premises = 22.1, rounded = 23

(c) Local Transport charges for 10,220 access minutes

- Assume ETCA rate for Local Transport mileband of over 16 to 25 miles is \$0.0120 per access minute
- Assume ETCA Billing Percentage (BP) is 57%
- Assume ETCB rate for Local Transport mileband of over 16 to 25 miles is \$0.0125 per access minute
- Assume ETCB Billing Percentage (BP) is 43%
- Formula:

$$\text{ETCA Local Transport Charge} = \frac{\text{Access Minutes} \times \text{ETCA Rate} \times \text{ETCA Billing Percentage}}{100}$$

- Calculation of Transport Charges

$$\text{ETCA Local Transport Charge} = 10,220 \times \$0.0120 \times 57\% = \$69.90$$

$$\text{ETCB Local Transport Charge} = 10,220 \times \$0.0125 \times 43\% = \$54.93$$

ISSUED:
March 30, 2007

Mark D. Harper
Director - State Regulatory
5454 W. 110th Street
Overland Park, Kansas 66211

EFFECTIVE:
April 30, 2007

CANCELED
July 1, 2012
Missouri Public
Service Commission
TT-2012-0317, YI-2012-0635

Filed
Missouri Public
Service Commission

SPRINT MISSOURI, INC.
d/b/a SPRINT

Second Revised Page 72
Cancels First Revised Page 72

Missouri Public

ACCESS SERVICE

REC'D JAN 15 2002

2. General Regulations (Cont'd)

Service Commission

2.4 Payment Arrangements and Credit Allowances (Cont'd)

2.4.8 Ordering, Rating and Billing of Access Services Where More Than One Exchange Telephone Company or Rate Schedule is Involved (Cont'd)

(B) (Cont'd)

(10) Example - Switched Access (Cont'd)

(b) Airline Mileages (Using National Exchange Carrier Association, *Inc.* (T)
Tariff F.C.C. No. 4).

- ETCA premises to ETCB premises = 22.1, rounded = 23

(c) Local Transport charges for 10,220 access minutes

- Assume ETCA rate for Local Transport mileband of over 16 to 25 miles is \$0.0120 per access minute

- Assume ETCA Billing Percentage (BP) is 57%

- Assume ETCB rate for Local Transport mileband of over 16 to 25 miles is \$0.0125 per access minute

- Assume ETCB Billing Percentage (BP) is 43%

- Formula:

$$\text{ETCA Local Transport Charge} = \frac{\text{Access Minutes} \times \text{ETCA Rate} \times \text{ETCA Billing Percentage}}{100}$$

- Calculation of Transport Charges

$$\text{ETCA Local Transport Charge} = 10,220 \times \$0.0120 \times 57\% = \$69.90$$

$$\text{ETCB Local Transport Charge} = 10,220 \times \$0.0125 \times 43\% = \$54.93$$

Missouri Public

FILED FEB 15 2002

Service Commission

ISSUED:
January 15, 2002

Richard D. Lawson
State Executive, External Affairs
319 Madison
Jefferson City, MO 65101

EFFECTIVE:
February 15, 2002

SPRINT MISSOURI, INC.
d/b/a SPRINT

First Revised Page 72
Cancels Original Page 72

ACCESS SERVICE

Missouri Public
Service Commission

2. General Regulations (Cont'd)

REGD NOV 29 2000

2.4 Payment Arrangements and Credit Allowances (Cont'd)

2.4.8 Ordering, Rating and Billing of Access Services Where More Than One Exchange Telephone Company or Rate Schedule is Involved (Cont'd)

(B) (Cont'd)

(10) Example - Switched Access (Cont'd)

(b) Airline Mileages (Using **National** Exchange Carrier Association (T)
Tariff **F.C.C. No. 4**). (T)

- ETCA premises to ETCB premises = 22.1, rounded = 23

(c) Local Transport charges for **10,220** access minutes (T)

- Assume ETCA rate for Local Transport mileband of over 16 to 25 miles is \$0.0120 per access minute

- Assume ETCA Billing Percentage (BP) is 57% (T)

- Assume ETCB rate for Local Transport mileband of over 16 to 25 miles is \$0.0125 per access minute

- Assume ETCB Billing Percentage (BP) is 43% (T)

- Formula:

$$\text{ETCA Local Transport Charge} = \frac{\text{Access Minutes} \times \text{ETCA Rate} \times \text{ETCA Billing Percentage}}{100}$$

- Calculation of Transport Charges

$$\text{ETCA Local Transport Charge} = 10,220 \times \$0.0120 \times 57\% = \$69.90 \quad (T)$$

$$\text{ETCB Local Transport Charge} = 10,220 \times \$0.0125 \times 43\% = \$54.93 \quad (T)$$

CANCELLED

FEB 15 2002

by *2nd RP 72*
Public Service Commission
MISSOURI

ISSUED:
November 29, 2000

Richard D. Lawson
State Executive, External Affairs
319 Madison
Jefferson City, MO 65101

EFFECTIVE:
December 29, 2000

Missouri Public
Service Commission

FILED DEC 29 2000

UNITED TELEPHONE COMPANY
OF MISSOURI

Original Page 72
RECEIVED

ACCESS SERVICE

SEP 17 1992

2. General Regulations (Cont'd)

MISSOURI

2.4 Payment Arrangements and Credit Allowances (Cont'd)

Public Service Commission

2.4.8 Ordering, Rating and Billing of Access Services Where More Than One Exchange Telephone Company or Rate Schedule is Involved
(Cont'd)

(B) (Cont'd)

(10) Example - Switched Access (Cont'd)

(b) Airline Mileages (Using Exchange Carrier Association Tariff).

- ETCA premises to ETCB premises = 22.1, rounded = 23

(c) Local Transport charges for 9000 access minutes

- Assume ETCA rate for Local Transport mileband of over 16 to 25 miles is \$0.0120 per access minute

- Assume ETCA Billing Percentage (BP) is 57

- Assume ETCB rate for Local Transport mileband of over 16 to 25 miles is \$0.0125 per access minute

- Assume ETCB Billing Percentage (BP) is 43

- Formula:

$$\text{ETCA Local Transport} = \frac{\text{Access Minutes} \times \text{ETCA Rate} \times \text{ETCA Billing Percentage}}{100}$$

- Calculation of Transport Charges

$$\text{ETCA Local Transport Charge} = 9000 \times \$0.0120 \times \frac{57}{100} = \$61.56$$

$$\text{ETCB Local Transport Charge} = 9000 \times \$0.0125 \times \frac{43}{100} = \$48.38$$

CANCELLED

DEC 29 2000

By *1st RP 72*
Public Service Commission
MISSOURI

FILED

NOV 7 1992

MISSOURI PUBLIC SERVICE COMMISSION

ISSUED:
September 17, 1992

BY: John L. Roe
Vice President - Administration
5454 West 110th Street
Overland Park, Kansas 66211

EFFECTIVE:
~~October 1, 1992~~
NOV 7 1992

ACCESS SERVICE

2. General Regulations (Cont'd)

2.4 Payment Arrangements and Credit Allowances (Cont'd)

2.4.8 Ordering, Rating and Billing of Access Services Where More Than One Exchange Telephone Company or Rate Schedule is Involved (Cont'd)

(B) (Cont'd)

(11) Example 2: Terminating Switched Access – Tandem 3rd Party
(See Diagram 2A and 2B)

- Feature Group D Switched Access is ordered to End Office.
- Terminating Access Tandem is owned by CLOC ILEC carrier (TC-A) and End Office is owned by a non-CLOC ILEC carrier (TC-B)
- Assumptions:
 - o TC-A Direct Trunk Transport BP = 40% (where applicable Diagram 2A)
 - o TC-B Direct Trunk Transport BP = 60% (where applicable Diagram 2A)
 - o Direct Trunk Transport mileage = 26 mi.
 - o TC-A Tandem Switched Transport BP = 20%
 - o TC-B Tandem Switched Transport BP = 80%
 - o Tandem Switched Transport mileage = 23 mi.

(N)

(N)

ISSUED:
May 1, 2017

Gary L. Kepley
Director - Regulatory Operations
600 New Century Parkway
New Century, Kansas 66031

EFFECTIVE:
July 1, 2017

FILED
Missouri Public
Service Commission
YI-2017-0229

CANCELLED - Missouri Public Service Commission - 07/14/2023 - IN-2023-0447 - YI-2024-0001

ACCESS SERVICE

(N)

2. General Regulations (Cont'd)

2.4 Payment Arrangements and Credit Allowances (Cont'd)

2.4.8 Ordering, Rating and Billing of Access Services Where More Than One Exchange Telephone Company or Rate Schedule is Involved (Cont'd)

(B) (Cont'd)

(11) Example 2: Terminating Switched Access – Tandem 3rd Party
(Cont'd)
(See Diagram 2A and 2B)

- Diagram 2A

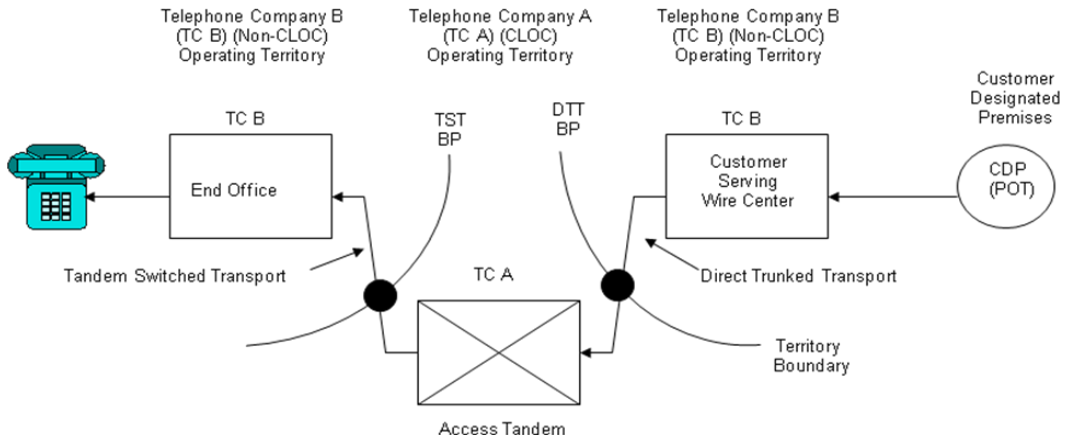

- Diagram 2B

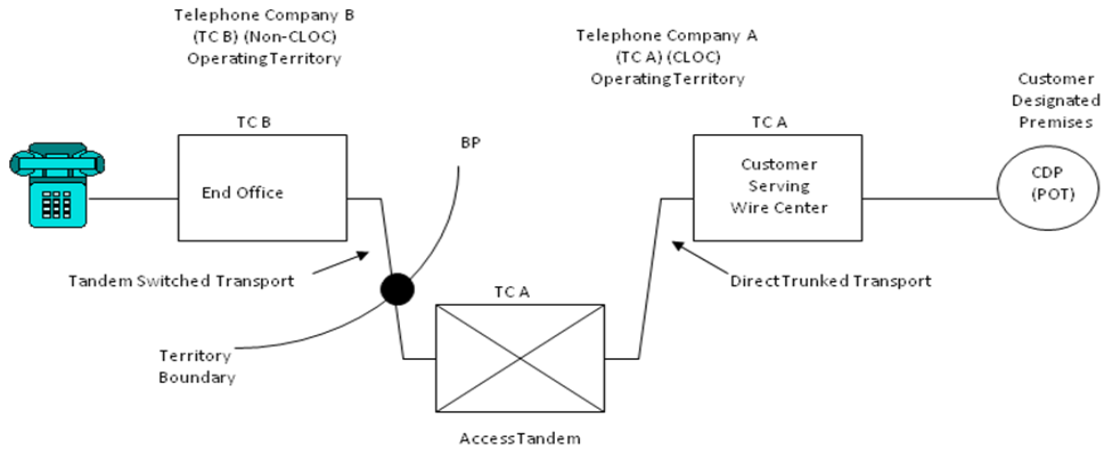

BP = Billing Percentage

(N)

ISSUED:
May 1, 2017

Gary L. Kepley
Director - Regulatory Operations
600 New Century Parkway
New Century, Kansas 66031

EFFECTIVE:
July 1, 2017

FILED
Missouri Public
Service Commission
YI-2017-0229

CANCELLED - Missouri Public Service Commission - 07/14/2023 - IN-2023-0447 - YI-2024-0001

ACCESS SERVICE

2. General Regulations (Cont'd)

2.4 Payment Arrangements and Credit Allowances (Cont'd)

2.4.8 Ordering, Rating and Billing of Access Services Where More Than One Exchange Telephone Company or Rate Schedule is Involved (Cont'd)

(B) (Cont'd)

(11) Example 2: Terminating Switched Access – Tandem 3rd Party
(Cont'd) (See Diagram 2A and 2B)

Example 2 Telephone Company A charges are:

Tandem Switched Facility – 3rd Party charge
= 9,000 min. x 23 mi. x TSF-3rd Party rate x 20%

Tandem Switched Termination – 3rd Party charge
= 1 termination x 9,000 min. x TST-3rd Party rate

Tandem Switching – 3rd Party charge
= 9,000 min. x TS-3rd Party rate

Direct Trunked Facility charge
2A = 26 miles x DTF rate x 40%
2B = 26 miles x DTF rate

Direct Trunked Termination charge
2A = 1 termination x DTT rate
2B = 2 termination x DTT rate

Common Transport Multiplexing – 3rd Party charge
= 9,000 min x CTM-3rd Party rate

(N)

(N)

CANCELLED - Missouri Public Service Commission - 07/14/2023 - IN-2023-0447 - YI-2024-0001

ISSUED:
May 1, 2017

Gary L. Kepley
Director - Regulatory Operations
600 New Century Parkway
New Century, Kansas 66031

EFFECTIVE:
July 1, 2017

FILED
Missouri Public
Service Commission
YI-2017-0229

ACCESS SERVICE

2. General Regulations (Cont'd)

2.4 Payment Arrangements and Credit Allowances (Cont'd)

2.4.8 Ordering, Rating and Billing of Access Services Where More Than One Exchange Telephone Company or Rate Schedule is Involved (Cont'd)

(B) (Cont'd)

(12) Example 3: Terminating Switched Access – Tandem End Office
(See Diagram 3)

- Feature Group D Switched Access is ordered to End Office.
- Terminating End Office and Access Tandem are both owned by a CLOC ILEC (TC-A)
- Assumptions:
 - o TC-A Direct Trunk Transport BP = 40%
 - o TC-B Direct Trunk Transport BP = 60%
 - o Direct Trunk Transport mileage = 26 mi.
 - o Tandem Switched Transport mileage = 23 mi.

Diagram 3

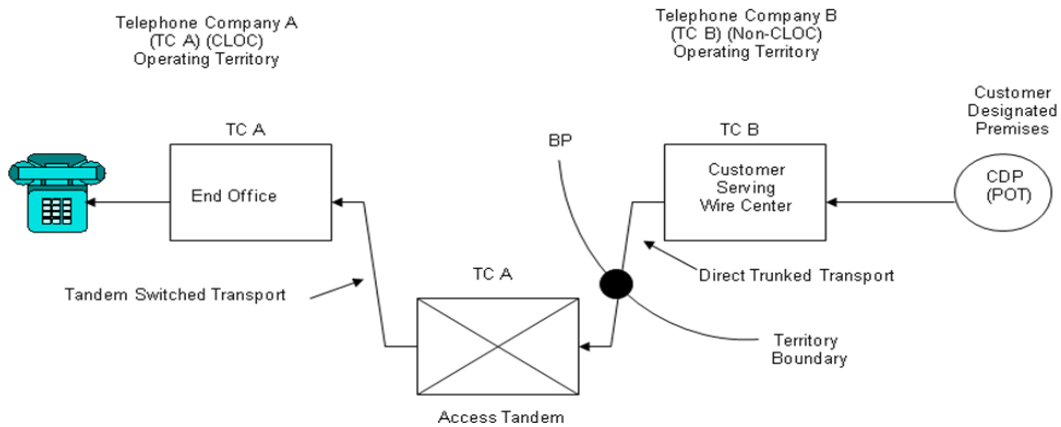

CANCELLED - Missouri Public Service Commission - 07/14/2023 - IN-2023-0447 - YI-2024-0001

(N)

(N)

ISSUED:
May 1, 2017

Gary L. Kepley
Director - Regulatory Operations
600 New Century Parkway
New Century, Kansas 66031

EFFECTIVE:
July 1, 2017

FILED
Missouri Public
Service Commission
YI-2017-0229

ACCESS SERVICE

2. General Regulations (Cont'd)

2.4 Payment Arrangements and Credit Allowances (Cont'd)

2.4.8 Ordering, Rating and Billing of Access Services Where More Than One Exchange Telephone Company or Rate Schedule is Involved (Cont'd)

(B) (Cont'd)

(12) Example 3: Terminating Switched Access – Tandem End Office
(Cont'd) (See Diagram 3)

- Telephone Company A charges are:

End Office Charges = 9,000 min. x EO rate

Tandem Switched Facility – End Office charge
= 9,000 min. x 23 mi. x TSF-End Office rate

Tandem Switched Termination – End Office charge
= 2 terminations x 9,000 min. x TST-End Office rate

Tandem Switching – End Office charge
= 9,000 min. x TS-End Office rate

Direct Trunked Facility Charge
= 26 miles x DTF rate x 40%

Direct Trunked Termination charge
= 1 termination x DTT rate

Common Transport Multiplexing – End Office charge
= 9,000 min x CTM-End Office rate

(N)

(N)

CANCELLED - Missouri Public Service Commission - 07/14/2023 - IN-2023-0447 - YI-2024-0001

ISSUED:
May 1, 2017

Gary L. Kepley
Director - Regulatory Operations
600 New Century Parkway
New Century, Kansas 66031

EFFECTIVE:
July 1, 2017

FILED
Missouri Public
Service Commission
YI-2017-0229

ACCESS SERVICE

2. General Regulations (Cont'd)

2.4 Payment Arrangements and Credit Allowances (Cont'd)

2.4.8 Ordering, Rating and Billing of Access Services Where More Than One Exchange Telephone Company or Rate Schedule is Involved (Cont'd)

(B) (Cont'd)

(13) Example 4: Originating Switched Access – CLOC owns only the End Office (See Diagram 4)

- Feature Group D Switched Access is ordered to End Office
- End Office is owned by CLOC (TC-A)
- Access Tandem is owned by a non-CLOC ILEC (TC-B)
- Assumptions:
 - o Direct Trunk Transport mileage = 26 mi.
 - o TC-A Tandem Switched Transport BP = 80%
 - o TC-B Tandem Switched Transport BP = 20%
 - o Tandem Switched Transport mileage = 23 mi.

Diagram 4

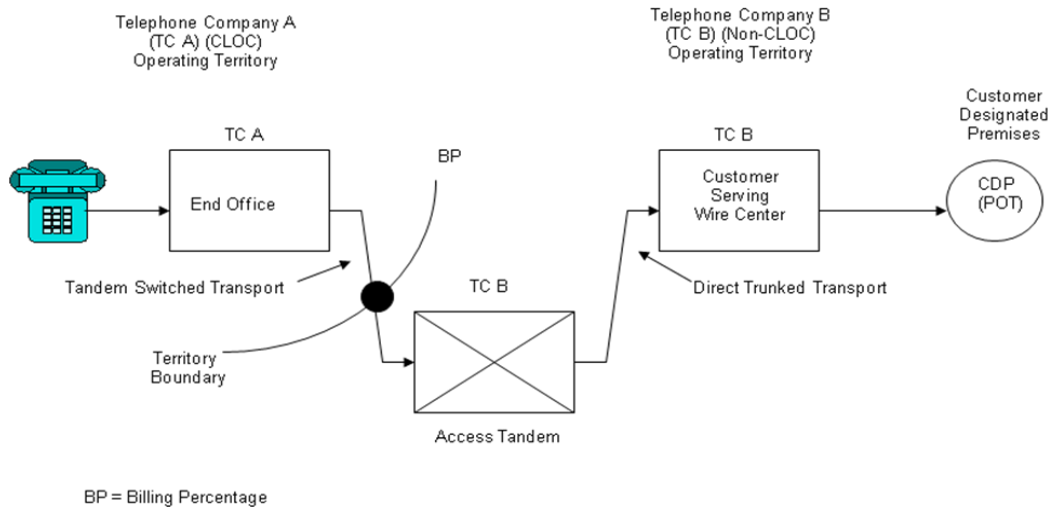

CANCELLED - Missouri Public Service Commission - 07/14/2023 - IN-2023-0447 - YI-2024-0001

(N)

(N)

ISSUED:
May 1, 2017

Gary L. Kepley
Director - Regulatory Operations
600 New Century Parkway
New Century, Kansas 66031

EFFECTIVE:
July 1, 2017

FILED
Missouri Public
Service Commission
YI-2017-0229

ACCESS SERVICE

2. General Regulations (Cont'd)

2.4 Payment Arrangements and Credit Allowances (Cont'd)

2.4.8 Ordering, Rating and Billing of Access Services Where More Than One Exchange Telephone Company or Rate Schedule is Involved (Cont'd)

(B) (Cont'd)

(13) Example 4: Originating Switched Access – CLOC owns only the End Office (Cont'd) (See Diagram 4)

- Telephone Company A charges are:

End Office charges = 9,000 min. x EO rate

Tandem Switched Facility charge
=9,000 min. x 23 mi. x TSF rate x 80%

Tandem Switched Termination charge
= 1 termination x 9,000 min. x TST rate

(N)

(N)

CANCELLED - Missouri Public Service Commission - 07/14/2023 - IN-2023-0447 - YI-2024-0001

ISSUED:
May 1, 2017

Gary L. Kepley
Director - Regulatory Operations
600 New Century Parkway
New Century, Kansas 66031

EFFECTIVE:
July 1, 2017

FILED
Missouri Public
Service Commission
YI-2017-0229

ACCESS SERVICE

2. General Regulations (Cont'd)

2.4 Payment Arrangements and Credit Allowances (Cont'd)

2.4.8 Ordering, Rating and Billing of Access Services Where More Than One Exchange Telephone Company or Rate Schedule is Involved (Cont'd)

(B) (Cont'd)

(14) Example 5: Terminating Switched Access – Tandem 3rd Party (See Diagram 5)

- Feature Group D Switched Access is ordered to End Office
- End Office is owned by Telephone Company (CLOC) (TC-A)
- Access Tandem is owned by a non-CLOC ILEC (TC-B)

Diagram 5

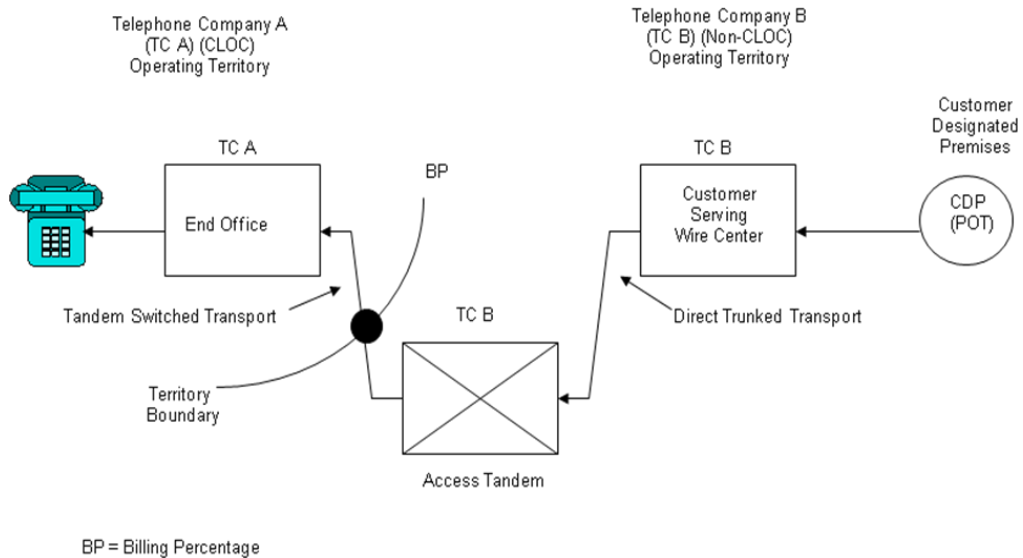

CANCELLED - Missouri Public Service Commission - 07/14/2023 - IN-2023-0447 - YI-2024-0001

(N)

(N)

ISSUED:
May 1, 2017

Gary L. Kepley
Director - Regulatory Operations
600 New Century Parkway
New Century, Kansas 66031

EFFECTIVE:
July 1, 2017

FILED
Missouri Public
Service Commission
YI-2017-0229

ACCESS SERVICE

2. General Regulations (Cont'd)

2.4 Payment Arrangements and Credit Allowances (Cont'd)

2.4.8 Ordering, Rating and Billing of Access Services Where More Than One Exchange Telephone Company or Rate Schedule is Involved (Cont'd)

(B) (Cont'd)

(14) Example 5: Terminating Switched Access – Tandem 3rd Party
(Cont'd) (See Diagram 5)

- Telephone Company A charges are:

End Office charges = 9,000 min. x EO rate

Tandem Switched Facility 3rd Party charge
= 9,000 min. x 23 mi. x TSF-3rd Party rate x 80%

Tandem Switched Termination 3rd Party charge
= 1 termination x 9,000 min. x TST-3rd Party rate

(N)

(N)

CANCELLED - Missouri Public Service Commission - 07/14/2023 - IN-2023-0447 - YI-2024-0001

ISSUED:
May 1, 2017

Gary L. Kepley
Director - Regulatory Operations
600 New Century Parkway
New Century, Kansas 66031

EFFECTIVE:
July 1, 2017

FILED
Missouri Public
Service Commission
YI-2017-0229

ACCESS SERVICE

2. General Regulations (Cont'd)

2.4 Payment Arrangements and Credit Allowances (Cont'd)

2.4.9 Service Performance Provisioning Guarantee

(A) General

The Telephone Company assures that orders for certain Access Services, as specified in (B) following, will be installed and available for customer use no later than the Firm Order Confirmation (FOC) date.

When the failure to meet a FOC date for installation of these services is solely the Telephone Company's responsibility, the associated nonrecurring charges shall be credited to the customer. The nonrecurring charges will be credited at the rate at which they were billed, however, the credit will not be provided if a credit of the same nonrecurring charge for the same service is provided under other provisions of this tariff. The credit of applicable nonrecurring charges for installations not completed by the FOC date is an exclusive remedy and is in lieu of any other claims described in Section 2.1.3 preceding.

(B) Services Subject to Credit

Service Performance Provisioning Guarantee is available for all Switched Access Services and for the following Special Access Services:

Voice Grade Service
Digital Data Service
High Capacity Service

(D)

ISSUED:
March 30, 2007

Mark D. Harper
Director - State Regulatory
5454 W. 110th Street
Overland Park, Kansas 66211

EFFECTIVE:
April 30, 2007

CANCELLED - Missouri Public Service Commission - 07/14/2023 - IN-2023-0447 - YI-2024-0001

SPRINT MISSOURI, INC.
d/b/a SPRINT

First Revised Page 72.1
Cancels Original Page 72.1

Missouri Public

ACCESS SERVICE

REC'D JAN 07 2002

2. General Regulations (Cont'd)

Service Commission

2.4 Payment Arrangements and Credit Allowances (Cont'd)

2.4.9 Service Performance Provisioning Guarantee

(A) General

The Telephone Company assures that orders for certain Access Services, as specified in (B) following, will be installed and available for customer use no later than the Firm Order **Confirmation** (FOC) date. (T)

When the failure to meet a FOC date for installation of these services is solely the Telephone Company's responsibility, the associated nonrecurring charges shall be credited to the customer. The nonrecurring charges will be credited at the rate at which they were billed, however, the credit will not be provided if a credit of the same nonrecurring charge for the same service is provided under other provisions of this tariff. The credit of applicable nonrecurring charges for installations not completed by the FOC date is an exclusive remedy and is in lieu of any other claims described in Section 2.1.3 preceding.

(B) Services Subject to Credit

Service Performance Provisioning Guarantee is available for all Switched Access Services and for the following Special Access Services:

- Program Audio Service
- Voice Grade Service
- Digital Data Service
- High Capacity Service

Missouri Public

FILED FEB 07 2002

Service Commission

ISSUED:
January 7, 2002

Richard D. Lawson
State Executive, External Affairs
319 Madison
Jefferson City, MO 65101

EFFECTIVE:
February 7, 2002

Cancelled

April 30, 2007
Missouri Public
Service Commission

UNITED TELEPHONE COMPANY
OF MISSOURI D/B/A SPRINT

Original **RECEIVED**

NOV 13 1996

ACCESS SERVICE

**MISSOURI
Public Service Commission** (N)

2. General Regulations (Cont'd)

2.4 Payment Arrangements and Credit Allowances (Cont'd)

2.4.9 Service Performance Provisioning Guarantee

(A) General

The Telephone Company assures that orders for certain Access Services, as specified in (B) following, will be installed and available for customer use no later than the Firm Order Commitment (FOC) date.

When the failure to meet a FOC date for installation of these services is solely the Telephone Company's responsibility, the associated nonrecurring charges shall be credited to the customer. The nonrecurring charges will be credited at the rate at which they were billed, however, the credit will not be provided if a credit of the same nonrecurring charge for the same service is provided under other provisions of this tariff. The credit of applicable nonrecurring charges for installations not completed by the FOC date is an exclusive remedy and is in lieu of any other claims described in Section 2.1.3 preceding.

(B) Services Subject to Credit

Service Performance Provisioning Guarantee is available for all Switched Access Services and for the following Special Access Services:

- Program Audio Service
- Voice Grade Service
- Digital Data Service
- High Capacity Service

(N)

CANCELLED

FEB 07 2002

151 RP 72.1

Public Service Commission
MISSOURI

FILED

DEC 16 1996

MO.PUBLICSERVICECOMM

ISSUED:
November 13, 1996

EFFECTIVE:
December 16, 1996

By: John L. Roe
Vice President - Carrier and Regulatory Services
5454 West 110th Street
Overland Park, Kansas 66211

ACCESS SERVICE

2. General Regulations (Cont'd)

2.4 Payment Arrangements and Credit Allowances (Cont'd)

2.4.9 Service Performance Provisioning Guarantee

(C) When a Credit Allowance Does Not Apply

Nonrecurring charge credits under the Service Performance Provisioning Guarantee will not be made:

- (1) When customer actions prevent or inhibit installation of the service (e.g., the customer's premises is inaccessible, the customer changes interface requirements, or the customer is not ready to accept the service).
- (2) When other Telephone Companies are involved in the service installation.
- (3) When the service is provided under the Special Construction or Specialized Services or Arrangements sections of this tariff.
- (4) During a declared national emergency, where priority installation of National Security Emergency Preparedness (NSEP) telecommunications services shall take precedence.
- (5) During natural disasters, work stoppages, civil disturbances, criminal actions; or by fire, flooding or other occurrences attributed to an Act of God.

ISSUED:
March 30, 2007

Mark D. Harper
Director - State Regulatory
5454 W. 110th Street
Overland Park, Kansas 66211

EFFECTIVE:
April 30, 2007

CANCELLED - Missouri Public Service Commission - 07/14/2023 - IN-2023-0447 - YI-2024-0001

RECEIVED

ACCESS SERVICE

2. General Regulations (Cont'd)

NOV 1 1996

2.4 Payment Arrangements and Credit Allowances (Cont'd)

2.4.9 Service Performance Provisioning Guarantee

MISSOURI
PUBLIC SERVICE COMMISSION

(C) When a Credit Allowance Does Not Apply

Nonrecurring charge credits under the Service Performance Provisioning Guarantee will not be made:

- (1) When customer actions prevent or inhibit installation of the service (e.g., the customer's premises is inaccessible, the customer changes interface requirements, or the customer is not ready to accept the service).
- (2) When other Telephone Companies are involved in the service installation.
- (3) When the service is provided under the Special Construction or Specialized Services or Arrangements sections of this tariff.
- (4) During a declared national emergency, where priority installation of National Security Emergency Preparedness (NSEP) telecommunications services shall take precedence.
- (5) During natural disasters, work stoppages, civil disturbances, criminal actions; or by fire, flooding or other occurrences attributed to an Act of God.

(N)

(N)

FILED

DEC 16 1996

MO. PUBLIC SERVICE COMM

ISSUED:
November 13, 1996

EFFECTIVE:
December 16, 1996

By: John L. Roe
Vice President - Carrier and Regulatory Services
5454 West 110th Street
Overland Park, Kansas 66211

ACCESS SERVICE

2. General Regulations (Cont'd)

2.5 Connections

2.5.1 General

Equipment and Systems (i.e., terminal equipment, multiline terminating systems and communications systems) may be connected with Switched and Special Access Service furnished by the Telephone Company where such connection is made in accordance with the provisions specified in Technical Reference Publications PUB AS No. 1 and in 2.1 preceding.

2.6 Definitions

Certain terms used herein are defined as follows:

Access Code

The term "Access Code" denotes a uniform seven digit code assigned by the Telephone Company to an individual customer. The seven digit code has the form 101-XXXX, 950-0XXX, 950-1XXX, or 950-00XX. The 100-XXXX access code will be provided where technically feasible.

Access Minutes

The term "Access Minutes" denotes that usage of exchange facilities in intrastate service for the purpose of calculating chargeable usage. On the originating end of an intrastate call, usage is measured from the time the originating end user's call is delivered by the Telephone Company to and acknowledged as received by the customer's facilities connected with the originating exchange. On the terminating end of an intrastate call, usage is measured from the time the call is received by the end user in the terminating exchange. Timing of usage at both originating and terminating ends of an intrastate call shall terminate when the calling or called party disconnects, whichever event is recognized first in the originating and terminating exchanges, as applicable.

ISSUED:
March 30, 2007

Mark D. Harper
Director - State Regulatory
5454 W. 110th Street
Overland Park, Kansas 66211

EFFECTIVE:
April 30, 2007

CANCELLED - Missouri Public Service Commission - 07/14/2023 - IN-2023-0447 - YI-2024-0001

SPRINT MISSOURI, INC.
d/b/a SPRINT

Third Revised Page 73
Cancels Second Page 73

ACCESS SERVICE

Missouri Public

REC'D JAN 15 2002

2. General Regulations (Cont'd)

Service Commission

2.5 Connections

2.5.1 General

Equipment and Systems (i.e., terminal equipment, multiline terminating systems and communications systems) may be connected with Switched and Special Access Service furnished by the Telephone Company where such connection is made in accordance with the provisions specified in Technical Reference Publications **PUB AS** No. 1 and in 2.1 preceding.

(T)

2.6 Definitions

Certain terms used herein are defined as follows:

Access Code

The term "Access Code" denotes a uniform seven digit code assigned by the Telephone Company to an individual customer. The seven digit code has the form 101-XXXX, 950-0XXX, 950-1XXX, or 950-00XX. The 100-XXXX access code will be provided where technically feasible.

Access Minutes

The term "Access Minutes" denotes that usage of exchange facilities in intrastate service for the purpose of calculating chargeable usage. On the originating end of an intrastate call, usage is measured from the time the originating end user's call is delivered by the Telephone Company to and acknowledged as received by the customer's facilities connected with the originating exchange. On the terminating end of an intrastate call, usage is measured from the time the call is received by the end user in the terminating exchange. Timing of usage at both originating and terminating ends of an intrastate call shall terminate when the calling or called party disconnects, whichever event is recognized first in the originating and terminating exchanges, as applicable.

Missouri Public

FILED FEB 15 2002

Service Commission

ISSUED:
January 15, 2002

Richard D. Lawson
State Executive, External Affairs
319 Madison
Jefferson City, MO 65101

EFFECTIVE:
February 15, 2002

Cancelled

April 30, 2007

Missouri Public

Service Commission

RECEIVED

ACCESS SERVICE

JUL 02 1998

2. General Regulations (Cont'd)

MO. PUBLIC SERVICE COMM

2.5 Connections

2.5.1 General

Equipment and Systems (i.e., terminal equipment, multiline terminating systems and communications systems) may be connected with Switched and Special Access Service furnished by the Telephone Company where such connection is made in accordance with the provisions specified in Technical Reference Publications AS No. 1 and in 2.1 preceding.

2.6 Definitions

Certain terms used herein are defined as follows:

Access Code

The term "Access Code" denotes a uniform seven digit code assigned by the Telephone Company to an individual customer. The seven digit code has the form 101XXXX, 950-0XXX, 950-1XXX, or 950-00XX.

(CT)

(CT)

(D)

Access Minutes

The term "Access Minutes" denotes that usage of exchange facilities in intrastate service for the purpose of calculating chargeable usage. On the originating end of an intrastate call, usage is measured from the time the originating end user's call is delivered by the Telephone Company to and acknowledged as received by the customer's facilities connected with the originating exchange. On the terminating end of an intrastate call, usage is measured from the time the call is received by the end user in the terminating exchange. Timing of usage at both originating and terminating ends of an intrastate call shall terminate when the calling or called party disconnects, whichever event is recognized first in the originating and terminating exchanges, as applicable.

CANCELLED

FEB 15 2002

By 314 RP 73

Public Service Commission
MISSOURI

FILED

AUG 03 1998

MISSOURI
Public Service Commission

UNITED TELEPHONE COMPANY
OF MISSOURI

First Revised Page 73
Cancels Original Page 73

RECEIVED

ACCESS SERVICE

JUN 5 1995

2. General Regulations (Cont'd)

MO. PUBLIC SERVICE COMM.

2.5 Connections

2.5.1 General

Equipment and Systems (i.e., terminal equipment, multiline terminating systems and communications systems) may be connected with Switched and Special Access Service furnished by the Telephone Company where such connection is made in accordance with the provisions specified in Technical Reference Publications AS No. 1 and in 2.1 preceding.

2.6 Definitions

Certain terms used herein are defined as follows:

Access Code

The term "Access Code" denotes a uniform five or seven digit code assigned by the Telephone Company to an individual customer. The five digit code has the form 10XXX, and the seven digit code has the form 101-XXXX, 950-0XXX, 950-1XXX, or 950-00XX. The 100-XXXX access code will be provided where technically feasible.

(C)
(C)

Access Minutes

The term "Access Minutes" denotes that usage of exchange facilities in intrastate service for the purpose of calculating chargeable usage. On the originating end of an intrastate call, usage is measured from the time the originating end user's call is delivered by the Telephone Company to and acknowledged as received by the customer's facilities connected with the originating exchange. On the terminating end of an intrastate call, usage is measured from the time the call is received by the end user in the terminating exchange. Timing of usage at both originating and terminating ends of an intrastate call shall terminate when the calling or called party disconnects, whichever event is recognized first in the originating and terminating exchanges, as applicable.

CANCELLED

AUG 03 1998
By *2nd RS #73*
Public Service Commission
MISSOURI

FILED

JUL 15 1995

MISSOURI
Public Service Commission

ISSUED:
June 5, 1995

By: John L. Roe
Vice President - Carrier and Regulatory Services
5454 West 110th Street
Overland Park, Kansas 66211

EFFECTIVE:
~~June 5, 1995~~
JUL 15 1995

ACCESS SERVICE

RECEIVED

SEP 17 1992

MISSOURI
Public Service Commission

2. General Regulations (Cont'd)

2.5 Connections

2.5.1 General

Equipment and Systems (i.e., terminal equipment, multiline terminating systems and communications systems) may be connected with Switched and Special Access Service furnished by the Telephone Company where such connection is made in accordance with the provisions specified in Technical Reference Publications AS No. 1 and in 2.1 preceding.

2.6 Definitions

Certain terms used herein are defined as follows:

Access Code

The term "Access Code" denotes a uniform five or seven digit code assigned by the Telephone Company to an individual customer. The five digit codes has the form 10XXX, and the seven digit code has the form 950-0XXX or 950-1XXX.

Access Minutes

The term "Access Minutes" denotes that usage of exchange facilities in intrastate service for the purpose of calculating chargeable usage. On the originating end of an intrastate call, usage is measured from the time the originating end user's call is delivered by the Telephone Company to and acknowledged as received by the customer's facilities connected with the originating exchange. On the terminating end of an intrastate call, usage is measured from the time the call is received by the end user in the terminating exchange. Timing of usage at both originating and terminating ends of an intrastate call shall terminate when the calling or called party disconnects, whichever event is recognized first in the originating and terminating exchanges, as applicable.

CANCELLED

JUL 15 1995
BY 1st R.S. # 73
Public Service Commission
MISSOURI

FILED
NOV 7 1992
M.O. PUBLIC SERVICE COMMISSION

ISSUED:
September 17, 1992

BY: John L. Roe
Vice President - Administration
5454 West 110th Street
Overland Park, Kansas 66211

EFFECTIVE:
~~October 17, 1992~~
NOV 7 1992

ACCESS SERVICE

2. General Regulations (Cont'd)

2.6 Definitions (Cont'd)

Access Tandem

The term "Access Tandem" denotes a Telephone Company switching system that provides a concentration and distribution function for originating or terminating traffic between end offices and a customer's premises.

Account

The term "Account" denotes the set of billing information for a customer. Each account is uniquely identified by the billing account number (BAN) located on either the customer's bill or service record.

Aggregator

The term "Aggregator" denotes any individual, partnership, association, joint-stock company, trust, governmental entity or corporation as defined under Part 64.708(b) of the Federal Communications Commission's Rules.

Alternate Billing Service

Alternate Billing Service (ABS) provides end users the ability to bill calls to an account not necessarily associated with the originating line.

Answer/Disconnect Supervision

The term "Answer/Disconnect Supervision" denotes the transmission of the switch trunk equipment supervisory signal (off-hook or on-hook) to the customer's point of termination as an indication that the called party has answered or disconnected.

Answer Message

Denotes an SS7 message sent in the backward direction to indicate that the call has been answered.

Attenuation Distortion

The term "Attenuation Distortion" denotes the difference in loss at specified frequencies relative to the loss at 1004 Hz, unless otherwise specified.

ISSUED:
March 30, 2007

Mark D. Harper
Director - State Regulatory
5454 W. 110th Street
Overland Park, Kansas 66211

EFFECTIVE:
April 30, 2007

ACCESS SERVICE

RECEIVED

2. General Regulations (Cont'd)

DEC 23 1993

2.6 Definitions (Cont'd)

MISSOURI
Public Service Commission

Access Tandem

The term "Access Tandem" denotes a Telephone Company switching system that provides a concentration and distribution function for originating or terminating traffic between end offices and a customer's premises.

Account

The term "Account" denotes the set of billing information for a customer. Each account is uniquely identified by the billing account number (BAN) located on either the customer's bill or service record.

Aggregator

The term "Aggregator" denotes any individual, partnership, association, joint-stock company, trust, governmental entity or corporation as defined under Part 64.708(b) of the Federal Communications Commission's Rules.

Alternate Billing Service

Alternate Billing Service (ABS) provides end users the ability to bill calls to an account not necessarily associated with the originating line.

Answer/Disconnect Supervision

The term "Answer/Disconnect Supervision" denotes the transmission of the switch trunk equipment supervisory signal (off-hook or on-hook) to the customer's point of termination as an indication that the called party has answered or disconnected.

Answer Message

Denotes an SS7 message sent in the backward direction to indicate that the call has been answered.

Attenuation Distortion

The term "Attenuation Distortion" denotes the difference in loss at specified frequencies relative to the loss at 1004 Hz, unless otherwise specified.

RECEIVED
JAN 24 1994

MISSOURI
Public Service Commission

ISSUE DATE:
December 23, 1993

BY: John L. Roe
Vice President - Administration
5454 West 110th Street
Overland Park, Kansas 66211

EFFECTIVE DATE:
January 24, 1994

(N)
(N)
(M)
(M)
(N)
(N)
(M)
(M)

UNITED TELEPHONE COMPANY
OF MISSOURI

Original Page 74

ACCESS SERVICE

RECEIVED

SEP 17 1992

MISSOURI
Public Service Commission

2. General Regulations (Cont'd)

2.6 Definitions (Cont'd)

Access Tandem

The term "Access Tandem" denotes a Telephone Company switching system that provides a concentration and distribution function for originating or terminating traffic between end offices and a customer's premises.

Answer/Disconnect Supervision

The term "Answer/Disconnect Supervision" denotes the transmission of the switch trunk equipment supervisory signal (off-hook or on-hook) to the customer's point of termination as an indication that the called party has answered or disconnected.

Attenuation Distortion

The term "Attenuation Distortion" denotes the difference in ^{JAN 24 1994} specified frequencies relative to the loss at 1004 Hz ^{unless otherwise specified.}

Balance (100 Type) Test Line

The term "Balance (100 Type) Test Line" denotes an arrangement in an end office which provides for balance and noise testing.

Bit

The term "Bit" denotes the smallest unit of information in the binary system of notation.

Business Day

The term "Business Day" denotes the times of day that a company is open for business. Generally, in the business community, these are 8:00 or 9:00 A.M. to 5:00 or 6:00 P.M., respectively, with an hour for lunch, Monday through Friday, resulting in an standard forty (40) hour work week. However, Business Day hours for the Telephone Company may vary based on company policy, union contract and location. To determine such hours for the Telephone Company, or company location, that company should be contacted at the address shown under the Issuing Carrier(s) name listed on Title Page 2 preceding.

CANCELLED

BY John R. S.
Public Service Commission
MISSOURI

FILED

NOV 7 1992

MO. PUBLIC SERVICE COMMISSION

ISSUED:
September 17, 1992

BY: John L. Roe
Vice President - Administration
5454 West 110th Street
Overland Park, Kansas 66211

EFFECTIVE:
~~October 1, 1992~~
NOV 7 1992

ACCESS SERVICE

2. General Regulations (Cont'd)

2.6 Definitions (Cont'd)

Balance (100 Type) Test Line

The term "Balance (100 Type) Test Line" denotes an arrangement in an end office which provides for balance and noise testing.

Billed Number Screening (BNS)

Billed number screening is a process which utilizes a data base to determine specific characteristics and/or customer preferences on a billed line number. Examples would include, whether or not the line is a pay telephone and whether the billed customer associated with the line will accept a collect call.

Bit

The term "Bit" denotes the smallest unit of information in the binary system of notation.

Business Day

The term "Business Day" denotes the times of day that a company is open for business. Generally, in the business community, these are 8:00 or 9:00 A.M. to 5:00 or 6:00 P.M., respectively, with an hour for lunch, Monday through Friday, resulting in an standard forty (40) hour work week. However, Business Day hours for the Telephone Company may vary based on company policy, union contract and location. To determine such hours for the Telephone Company, or company location, that company should be contacted at the address shown under the Issuing Carrier(s) name listed on Title Page 2 preceding.

ISSUED:
March 30, 2007

Mark D. Harper
Director - State Regulatory
5454 W. 110th Street
Overland Park, Kansas 66211

EFFECTIVE:
April 30, 2007

CANCELLED - Missouri Public Service Commission - 07/14/2023 - IN-2023-0447 - YI-2024-0001

SECRET

ACCESS SERVICE

JAN 15 1997

2. General Regulations (Cont'd)

2.6 Definitions (Cont'd)

MISSOURI
Public Service Commission

Balance (100 Type) Test Line

The term "Balance (100 Type) Test Line" denotes an arrangement in an end office which provides for balance and noise testing.

Billed Number Screening (BNS)

Billed number screening is a process which utilizes a data base to determine specific characteristics and/or customer preferences on a billed line number. Examples would include, whether or not the line is a pay telephone and whether the billed customer associated with the line will accept a collect call. (T)

Bit

The term "Bit" denotes the smallest unit of information in the binary system of notation.

Business Day

The term "Business Day" denotes the times of day that a company is open for business. Generally, in the business community, these are 8:00 or 9:00 A.M. to 5:00 or 6:00 P.M., respectively, with an hour for lunch, Monday through Friday, resulting in a standard forty (40) hour work week. However, Business Day hours for the Telephone Company may vary based on company policy, union contract and location. To determine such hours for the Telephone Company, or company location, that company should be contacted at the address shown under the Issuing Carrier(s) name listed on Title Page 2 preceding.

FILED

APR 15 1997

MO. PUBLIC SERVICE COMMISSION

ISSUED:
January 15, 1997

BY: John L. Roe
VP - Carrier and Regulatory Services
5454 West 110th Street
Overland Park, Kansas 66211

EFFECTIVE:

APR 15 1997

Cancelled

April 30, 2007
Missouri Public
Service Commission

RECEIVED

DEC 23 1993

**MISSOURI
Public Service Commission**

ACCESS SERVICE

2. General Regulations (Cont'd)

2.6 Definitions (Cont'd)

Balance (100 Type) Test Line

The term "Balance (100 Type) Test Line" denotes an arrangement in an end office which provides for balance and noise testing. (M)

Billed Number Screening (BNS)

Billed number screening is a process which utilizes a data base to determine specific characteristics and/or customer preferences on a billed line number. Examples would include, whether or not the line is a public telephone and whether the billed customer associated with the line will accept a collect call.

Bit

The term "Bit" denotes the smallest unit of information in the binary system of notation. (M)

Business Day

The term "Business Day" denotes the times of day that a company is open for business. Generally, in the business community, these are 8:00 or 9:00 A.M. to 5:00 or 6:00 P.M., respectively, with an hour for lunch, Monday through Friday, resulting in an standard forty (40) hour work week. However, Business Day hours for the Telephone Company may vary based on company policy, union contract and location. To determine such hours for the Telephone Company, or company location, that company should be contacted at the address shown under the Issuing Carrier(s) name listed on Title Page 2 preceding. (M)

CANCELLED

APR 15 1997
BY *Lat P.S. 741*
Public Service Commission
MISSOURI

FILED

JAN 24 1994

**MISSOURI
Public Service Commission**

ISSUE DATE:
December 23, 1993

BY: John L. Roe
Vice President - Administration
5454 West 110th Street
Overland Park, Kansas 66211

EFFECTIVE DATE:
January 24, 1994

ACCESS SERVICE

2. General Regulations (Cont'd)

2.6 Definitions (Cont'd)

Call

The term "Call" denotes a customer attempt for which the complete address code (e.g., o-, 911, or 10 digits) is provided to the serving dial tone office.

Carrier or Common Carrier

See Interexchange Carrier.

Carrier Access Code (CAC)

The term "Carrier Access Code" denotes a uniform seven-digit code assigned by the Telephone Company to an individual customer. The seven-digit code has the form 101XXXX, 950-XXXX, 950-1XXX, 950-10XX or 950-00XX. The 101XXXX access code will be provided where technically feasible.

Carrier Identification Code (CIC)

The term "Carrier Identification Code" denotes numeric codes that are assigned to an IC for use with Feature Groups B and/or D Switched Access Service.

Carrier Identification Parameter

The term "Carrier Identification Parameter (CIP)" denotes a field in the SS7 initial address message that identifies and forwards Carrier Identification Code information to an interexchange carrier.

CCS

The term "CCS" denotes a hundred call seconds, which is a standard unit of traffic load that is equal to 100 seconds of usage or capacity of a group of servers (e.g., trunks).

ISSUED:
March 30, 2007

Mark D. Harper
Director - State Regulatory
5454 W. 110th Street
Overland Park, Kansas 66211

EFFECTIVE:
April 30, 2007

CANCELLED - Missouri Public Service Commission - 07/14/2023 - IN-2023-0447 - YI-2024-0001

SPRINT MISSOURI, INC.
d/b/a SPRINT

Second Revised Page 75
Cancels First Revised Page 75
Missouri Public
Service Commission

ACCESS SERVICE

REC'D NOV 29 2000

2. General Regulations (Cont'd)

2.6 Definitions (Cont'd)

(D)

(D)

Call

The term "Call" denotes a customer attempt for which the complete address code (e.g., 0-, 911, or 10 digits) is provided to the serving dial tone office.

Carrier or Common Carrier

See Interexchange Carrier.

Carrier Access Code (CAC)

(N)

The term "Carrier Access Code" denotes a uniform seven-digit code assigned by the Telephone Company to an individual customer. The seven-digit code has the form 101XXXX, 950-XXXX, 950-1XXX, 950-10XX or 950-00XX. The 101XXXX access code will be provided where technically feasible.

Carrier Identification Code (CIC)

The term "Carrier Identification Code" denotes numeric codes that are assigned to an IC for use with Feature Groups B and/or D Switched Access Service.

(N)

Carrier Identification Parameter

The term "Carrier Identification Parameter (CIP)" denotes a field in the SS7 initial address message that identifies and forwards Carrier Identification Code information to an interexchange carrier.

CCS

The term "CCS" denotes a hundred call seconds, which is a standard unit of traffic load that is equal to 100 seconds of usage or capacity of a group of servers (e.g., trunks).

ISSUED:
November 29, 2000

Richard D. Lawson
State Executive, External Affairs
319 Madison
Jefferson City, MO 65101

EFFECTIVE:
December 29, 2000
Missouri Public
Service Commission

FILED DEC 29 2000

UNITED TELEPHONE COMPANY
OF MISSOURI d/b/a SPRINT

First Revised Page 75
Cancels Original Page 75

RECEIVED

ACCESS SERVICE

2. General Regulations (Cont'd)

SEP - 4 1997

2.6 Definitions (Cont'd)

MO PUBLIC SERVICE COMMISSION

Busy Hours Minutes of Capacity (BHMC)

The term "Busy Hours Minutes of Capacity (BHMC)" denotes the customer specified maximum amount of Switched Access Service and/or Directory Assistance Service access minutes the customer expects to be handled in an end office switch during any hour in an 8:00 a.m. to 11:090 p.m. period for the Feature Group and/or Directory Assistance Service ordered. This customer furnished BHMC quantity is the input data the Telephone Company uses to determine the number of transmission paths for the Feature Group and/or Directory Assistance Service ordered.

Call

The term "Call" denotes a customer attempt for which the complete address code (e.g., 0-, 911, or 10 digits) is provided to the serving dial tone office.

Carrier or Common Carrier

See Interexchange Carrier.

Carrier Identification Parameter

The term "Carrier Identification Parameter (CIP)" denotes a field in the SS7 initial address message that identifies and forwards Carrier Identification Code information to an interexchange carrier.

(N)
|
(N)

CCS

The term "CCS" denotes a hundred call seconds, which is a standard unit of traffic load that is equal to 100 seconds of usage or capacity of a group of servers (e.g., trunks).

CANCELLED

FILED

DEC 29 2000
By *2nd RP 75*
Public Service Commission
MISSOURI

OCT - 6 1997

MISSOURI
Public Service Commission

ISSUED:
September 4, 1997

BY: John L. Roe
VP - Carrier and Regulatory Services
5454 West 110th Street
Overland Park, Kansas 66211

EFFECTIVE:
October 6, 1997

ACCESS SERVICE

RECEIVED

SEP 17 1992

2. General Regulations (Cont'd)

MISSOURI
Public Service Commission

2.6 Definitions (Cont'd)

Busy Hour Minutes of Capacity (BHMC)

The term "Busy Hour Minutes of Capacity (BHMC)" denotes the customer specified maximum amount of Switched Access Service and/or Directory Assistance Service access minutes the customer expects to be handled in an end office switch during any hour in an 8:00 A.M. to 11:00 P.M. period for the Feature Group and/or Directory Assistance Service ordered. This customer furnished BHMC quantity is the input data the Telephone Company uses to determine the number of transmission paths for the Feature Group and/or Directory Assistance Service ordered.

Call

The term "Call" denotes a customer attempt for which the complete address code (e.g., 0-, 911, or 10 digits) is provided to the serving dial tone office.

Carrier or Common Carrier

See Interexchange Carrier.

CCS

The term "CCS" denotes a hundred call seconds, which is a standard unit of traffic load that is equal to 100 seconds of usage or capacity of a group of servers (e.g., trunks).

CANCELLED

OCT -6 1997
By 1st P.S. #15
Public Service Commission
MISSOURI

FILED

NOV 7 1992

MO. PUBLIC SERVICE COMMISSION

ISSUED:
September 17, 1992

BY: John L. Roe
Vice President - Administration
5454 West 110th Street
Overland Park, Kansas 66211

EFFECTIVE:
~~October 1, 1992~~
NOV 7 1992

ACCESS SERVICE

2. General Regulations (Cont'd)

2.6 Definitions (Cont'd)

Central Office

The term "Central Office" denotes a local Telephone Company switching system where Telephone Exchange Service customer station loops are terminated for purposes of interconnection to each other and to trunks.

Central Office Prefix

The term "Central Office Prefix" denotes the first three digits (NXX) of the seven digit telephone number assigned to a customer's Telephone Exchange Service when dialed on a local basis.

Centralized Automatic Reporting on Trunks Testing

The term "Centralized Automatic Reporting on Trunks Testing" denotes a type of testing which includes the capacity for measuring operational and transmission parameters.

Channel

The term "Channel(s)" denotes an electrical or photonic, in the case of fiber optic-based transmission systems, communications path between two or more points of termination.

Channel Service Unit

The term "Channel Service Unit" denotes equipment which performs one or more of the following functions: termination of a digital facility, regeneration of digital signals, detection and/or correction of signal format errors and remote loop back.

Channelize

The term "Channelize" denotes the process of multiplexing/ demultiplexing wider bandwidth or higher speed channels into narrower bandwidth or lower speed channels.

Clear Channel Capability

The term "Clear Channel Capability" denotes the transport of twenty-four, 64 Kbps channels over a 1.544 Mbps High Capacity Service via B8ZS line code format.

ISSUED:
March 30, 2007

Mark D. Harper
Director - State Regulatory
5454 W. 110th Street
Overland Park, Kansas 66211

EFFECTIVE:
April 30, 2007

CANCELLED - Missouri Public Service Commission - 07/14/2023 - IN-2023-0447 - YI-2024-0001

UNITED TELEPHONE COMPANY
OF MISSOURI

First Revised Page 76
Cancels Original Page 76

RECEIVED

ACCESS SERVICE

2. General Regulations (Cont'd)

FEB 28 1995

2.6 Definitions (Cont'd)

MO. PUBLIC SERVICE COMM.

Central Office

The term "Central Office" denotes a local Telephone Company switching system where Telephone Exchange Service customer station loops are terminated for purposes of interconnection to each other and to trunks.

Central Office Prefix

The term "Central Office Prefix" denotes the first three digits (NXX) of the seven digit telephone number assigned to a customer's Telephone Exchange Service when dialed on a local basis.

Centralized Automatic Reporting on Trunks Testing

The term "Centralized Automatic Reporting on Trunks Testing" denotes a type of testing which includes the capacity for measuring operational and transmission parameters.

Channel(s)

The term "Channel(s)" denotes an electrical or photonic, in the case of fiber optic-based transmission systems, communications path between two or more points of termination.

Channel Service Unit

The term "Channel Service Unit" denotes equipment which performs one or more of the following functions: termination of a digital facility, regeneration of digital signals, detection and/or correction of signal format errors and remote loop back.

Channelize

The term "Channelize" denotes the process of multiplexing/demultiplexing wider bandwidth or higher speed channels into narrower bandwidth or lower speed channels.

Clear Channel Capability

The term "Clear Channel Capability" denotes the transport of twenty-four, 64 Kbps channels over a 1.544 Mbps High Capacity Service via B8ZS line code format.

(N)
|
(N)

FILED

MAR 8 1995

MISSOURI
Public Service Commission

ISSUED:
February 28, 1995

BY: John L. Roe
Vice President - Carrier and Regulatory Services
5454 West 110th Street
Overland Park, Kansas 66211

EFFECTIVE:
March 31, 1995

Cancelled
April 30, 2007
Missouri Public
Service Commission

UNITED TELEPHONE COMPANY
OF MISSOURI

Original Page 76

RECEIVED

SEP 17 1992

MISSOURI
Public Service Commission

ACCESS SERVICE

2. General Regulations (Cont'd)

2.6 Definitions (Cont'd)

Central Office

The term "Central Office" denotes a local Telephone Company switching system where Telephone Exchange Service customer station loops are terminated for purposes of interconnection to each other and to trunks.

Central Office Prefix

The term "Central Office Prefix" denotes the first three digits (NXX) of the seven digit telephone number assigned to a customer's Telephone Exchange Service when dialed on a local basis.

Centralized Automatic Reporting on Trunks Testing

The term "Centralized Automatic Reporting on Trunks Testing" denotes a type of testing which includes the capacity for measuring operational and transmission parameters.

Channel(s)

The term "Channel(s)" denotes an electrical or photonic, in the case of fiber optic-based transmission systems, communications path between two or more points of termination.

Channel Service Unit

The term "Channel Service Unit" denotes equipment which performs one or more of the following functions: termination of a digital facility, regeneration of digital signals, detection and/or correction of signal format errors and remote loop back.

Channelize

The term "Channelize" denotes the process of multiplexing/demultiplexing wider bandwidth or higher speed channels into narrower bandwidth or lower speed channels.

CANCELLED

MAR 31 1995
BY 1st R.S. #76
Public Service Commission
MISSOURI

FILED

NOV 7 1992

MO. PUBLIC SERVICE COMMISSION

ISSUED:
September 17, 1992

BY: John L. Roe
Vice President - Administration
5454 West 110th Street
Overland Park, Kansas 66211

EFFECTIVE:
~~October 1, 1992~~

NOV 7 1992

ACCESS SERVICE

2. General Regulations (Cont'd)

2.6 Definitions (Cont'd)

C-Message Noise

The term "C-Message Noise" denotes the frequency weighted average noise within an idle voice channel. The frequency weighting, called C-message, is used to simulate the frequency characteristic of the 500-type telephone set and the hearing of the average subscriber.

C-Notched Noise

The term "C-Notched Noise" denotes the C-message frequency weighted noise on a voice channel with a holding tone, which is removed at the measuring end through a notch (very narrow band) filter.

Common Line

The term "Common Line" denotes a line, trunk, pay telephone line or other facility provided under the general and/or local exchange service tariffs of the Telephone Company, terminated on a central office switch. A common line-residence is a line or trunk provided under the residence regulations of the general and/or local exchange service tariffs. A common line-business is a line provided under the business regulations of the general and/or local exchange service tariffs.

Common Trunk Port

The term "Common Trunk Port" denotes the termination of shared access trunks when traffic is routed to an end office through an access tandem, host office or dial tone office.

(N)
|
(N)

Communications System

The term "Communications System" denotes channels and other facilities which are capable of communications between terminal equipment provided by other than the Telephone Company.

Customer(s)

The term "Customer(s)" denotes any individual, partnership, association, joint-stock company, trust, corporation, or governmental entity or any other entity which subscribes to the services offered under this tariff, including both Interexchange Carriers (ICs) and end users. For purposes of this tariff, Local Exchange Carriers that participate in the Primary Carrier by Toll Center Plan are included in this definition.

CANCELLED - Missouri Public Service Commission - 07/14/2023 - IN-2023-0447 - YI-2024-0001

ISSUED:
May 1, 2012

Gary L. Kepley
Director - Regulatory Operations
5454 W. 110th Street
Overland Park, Kansas 66211

FILED
Missouri Public
Service Commission
EFFECTIVE:
July 3, 2012
TT-2012-0317, YI-2012-0635

ACCESS SERVICE

2. General Regulations (Cont'd)

2.6 Definitions (Cont'd)

C-Message Noise

The term "C-Message Noise" denotes the frequency weighted average noise within an idle voice channel. The frequency weighting, called C-message, is used to simulate the frequency characteristic of the 500-type telephone set and the hearing of the average subscriber.

C-Notched Noise

The term "C-Notched Noise" denotes the C-message frequency weighted noise on a voice channel with a holding tone, which is removed at the measuring end through a notch (very narrow band) filter.

Common Line

The term "Common Line" denotes a line, trunk, pay telephone line or other facility provided under the general and/or local exchange service tariffs of the Telephone Company, terminated on a central office switch. A common line-residence is a line or trunk provided under the residence regulations of the general and/or local exchange service tariffs. A common line-business is a line provided under the business regulations of the general and/or local exchange service tariffs.

Communications System

The term "Communications System" denotes channels and other facilities which are capable of communications between terminal equipment provided by other than the Telephone Company.

Customer(s)

The term "Customer(s)" denotes any individual, partnership, association, joint-stock company, trust, corporation, or governmental entity or any other entity which subscribes to the services offered under this tariff, including both Interexchange Carriers (ICs) and end users. For purposes of this tariff, Local Exchange Carriers that participate in the Primary Carrier by Toll Center Plan are included in this definition.

ISSUED:
March 30, 2007

Mark D. Harper
Director - State Regulatory
5454 W. 110th Street
Overland Park, Kansas 66211

EFFECTIVE:
April 30, 2007

CANCELED
July 1, 2012
Missouri Public
Service Commission
TT-2012-0317, YI-2012-0635

Filed
Missouri Public
Service Commission

UNITED TELEPHONE COMPANY
OF MISSOURI d/b/a SPRINT

First Revised Page 77
Cancels Original Page 77

ACCESS SERVICE

FILED

2. General Regulations (Cont'd)

APR 15 1997

2.6 Definitions (Cont'd)

MISSOURI
Public Service Commission

C-Message Noise

The term "C-Message Noise" denotes the frequency weighted average noise within an idle voice channel. The frequency weighting, called C-message, is used to simulate the frequency characteristic of the 500-type telephone set and the hearing of the average subscriber.

C-Notched Noise

The term "C-Notched Noise" denotes the C-message frequency weighted noise on a voice channel with a holding tone, which is removed at the measuring end through a notch (very narrow band) filter.

(D)
|
(D)

Common Line

The term "Common Line" denotes a line, trunk, pay telephone line or other facility provided under the general and/or local exchange service tariffs of the Telephone Company, terminated on a central office switch. A common line-residence is a line or trunk provided under the residence regulations of the general and/or local exchange service tariffs. A common line-business is a line provided under the business regulations of the general and/or local exchange service tariffs.

Communications System

The term "Communications System" denotes channels and other facilities which are capable of communications between terminal equipment provided by other than the Telephone Company.

Customer(s)

The term "Customer(s)" denotes any individual, partnership, association, joint-stock company, trust, corporation, or governmental entity or any other entity which subscribes to the services offered under this tariff, including both Interexchange Carriers (ICs) and end users. For purposes of this tariff, Local Exchange Carriers that participate in the Primary Carrier by Toll Center Plan are included in this definition.

FILED
APR 15 1997
TO PUBLIC RECORDS

ISSUED:
January 15, 1997

BY: John L. Roe
VP - Carrier and Regulatory Services
5454 West 110th Street
Overland Park, Kansas 66211

EFFECTIVE:
APR 15 1997

Cancelled
April 30, 2007
Missouri Public
Service Commission

UNITED TELEPHONE COMPANY
OF MISSOURI

Original Page 77

RECEIVED

SEP 17 1992

MISSOURI
Public Service Commission

ACCESS SERVICE

2. General Regulations (Cont'd)

2.6 Definitions (Cont'd)

C-Message Noise

The term "C-Message Noise" denotes the frequency weighted average noise within an idle voice channel. The frequency weighting, called C-message, is used to simulate the frequency characteristic of the 500-type telephone set and the hearing of the average subscriber.

C-Notched Noise

The term "C-Notched Noise" denotes the C-message frequency weighted noise on a voice channel with a holding tone, which is removed at the measuring end through a notch (very narrow band) filter.

Coin Station

The term "Coin Station" denotes a location where Telephone Company equipment is provided in a public or semipublic place where Telephone Company customers can originate telephonic communications and pay the applicable charges by inserting coins into the equipment.

Common Line

The term "Common Line" denotes a line, trunk, pay telephone, or other facility provided under the general and/or local exchange service tariffs of the Telephone Company, terminated on a central office switch. A common line-residence is a line or trunk provided under the residence regulations of the general and/or local exchange service tariffs. A common line-business is a line provided under the business regulations of the general and/or local exchange service tariffs.

Communications System

The term "Communications System" denotes channels and other facilities which are capable of communications between terminal equipment provided by other than the Telephone Company.

Customer(s)

The term "Customer(s)" denotes any individual, partnership, association, joint-stock company, trust, corporation, or governmental entity or any other entity which subscribes to the services offered under this tariff, including both Interexchange Carriers (ICs) and end users. For purposes of this tariff, Local Exchange Carriers that participate in the Primary Carrier by Toll Center Plan are included in this definition.

CANCELLED
APR 15 1997
BY: J. P. S. #17
Public Service Commission
MISSOURI

NOV 7 1992

ISSUED:
September 17, 1992

BY: John L. Roe
Vice President - Administration
5454 West 110th Street
Overland Park, Kansas 66211

MO. PUBLIC SERVICE COMMISSION
EFFECTIVE DATE

NOV 7 1992

ACCESS SERVICE

2. General Regulations (Cont'd)

2.6 Definitions (Cont'd)

Data Transmission (107 Type) Test Line

The term "Data Transmission (107 Type) Test Line" denotes an arrangement which provides for a connection to a signal source which provides test signals for one-way testing of data and voice transmission parameters.

Decibel

The term "Decibel" denotes a unit used to express relative difference in power, usually between acoustic or electric signals, equal to ten (10) times the common logarithm of the ratio of two signal powers.

Decibel Reference Noise C-Message Weighting

The term "Decibel Reference Noise C-Message Weighting" denotes noise power measurements with C-Message weighting in decibels relative to a reference 1000 Hz tone of 90 dB below 1 milliwatt.

Decibel Reference Noise C-Message Referenced to 0

The term "Decibel Reference Noise C-Message Referenced to 0" denotes noise power in "Decibel Reference Noise C-Message Weighting" referred to or measured at a zero transmission level point.

Dedicated Trunk Port

The term "Dedicated Trunk Port" denotes the termination of Feature Group B and D access trunks to an end office when provided as a trunk side arrangement or to the access tandem at the serving wire center side of the switch.

Detail Billing

The term "Detail Billing" denotes the listing of each message and/or rate element for which charges to a customer are due on a bill prepared by the Telephone Company.

Direct-Trunked Transport

The term "Direct-Trunked Transport" denotes switched access transport from the serving wire center to the end office on circuits dedicated to the use of a single access customer without tandem switching, or from the serving wire center to the access tandem when the transport from the access tandem to the end office is routed on circuits used in common by multiple access customers.

(N)

(N)

(N)

(N)

(M)

(M)

(M) Material omitted from this page now appears on Page 79.

ISSUED:
May 1, 2012

Gary L. Kepley
Director - Regulatory Operations
5454 W. 110th Street
Overland Park, Kansas 66211

FILED
Missouri Public
Service Commission
EFFECTIVE:
July 3, 2012
TT-2012-0317, YI-2012-0635

CANCELLED - Missouri Public Service Commission - 07/14/2023 - IN-2023-0447 - YI-2024-0001

ACCESS SERVICE

2. General Regulations (Cont'd)

2.6 Definitions (Cont'd)

Data Transmission (107 Type) Test Line

The term "Data Transmission (107 Type) Test Line" denotes an arrangement which provides for a connection to a signal source which provides test signals for one-way testing of data and voice transmission parameters.

Decibel

The term "Decibel" denotes a unit used to express relative difference in power, usually between acoustic or electric signals, equal to ten (10) times the common logarithm of the ratio of two signal powers.

Decibel Reference Noise C-Message Weighting

The term "Decibel Reference Noise C-Message Weighting" denotes noise power measurements with C-Message weighting in decibels relative to a reference 1000 Hz tone of 90 dB below 1 milliwatt.

Decibel Reference Noise C-Message Referenced to 0

The term "Decibel Reference Noise C-Message Referenced to 0" denotes noise power in "Decibel Reference Noise C-Message Weighting" referred to or measured at a zero transmission level point.

Detail Billing

The term "Detail Billing" denotes the listing of each message and/or rate element for which charges to a customer are due on a bill prepared by the Telephone Company.

Directory Assistance (Intrastate)

The term "Directory Assistance" denotes the provision of telephone numbers by a Telephone Company operator when the operator location is accessed by a customer premises by sending appropriate signals, i.e. off-hook, 411, 1411, 555-1212 or (NPA) 555-1212.

ISSUED:
March 30, 2007

Mark D. Harper
Director - State Regulatory
5454 W. 110th Street
Overland Park, Kansas 66211

EFFECTIVE:
April 30, 2007

CANCELED
July 1, 2012
Missouri Public
Service Commission
TT-2012-0317, YI-2012-0635

Filed
Missouri Public
Service Commission

UNITED TELEPHONE COMPANY
OF MISSOURI

Original Page 78

RECEIVED

SEP 17 1992

MISSOURI
Public Service Commission

ACCESS SERVICE

2. General Regulations (Cont'd)

2.6 Definitions (Cont'd)

Data Transmission (107 Type) Test Line

The term "Data Transmission (107 Type) Test Line" denotes an arrangement which provides for a connection to a signal source which provides test signals for one-way testing of data and voice transmission parameters.

Decibel

The term "Decibel" denotes a unit used to express relative difference in power, usually between acoustic or electric signals, equal to ten (10) times the common logarithm of the ratio of two signal powers.

Decibel Reference Noise C-Message Weighting

The term "Decibel Reference Noise C-Message Weighting" denotes noise power measurements with C-Message weighting in decibels relative to a reference 1000 Hz tone of 90 dB below 1 milliwatt.

Decibel Reference Noise C-Message Referenced to 0

The term "Decibel Reference Noise C-Message Referenced to 0" denotes noise power in "Decibel Reference Noise C-Message Weighting" referred to or measured at a zero transmission level point.

Detail Billing

The term "Detail Billing" denotes the listing of each message and/or rate element for which charges to a customer are due on a bill prepared by the Telephone Company.

Directory Assistance (Intrastate)

The term "Directory Assistance" denotes the provision of telephone numbers by a Telephone Company operator when the operator location is accessed by a customer premises by sending appropriate signals, i.e. off-hook, 411, 1411, 555-1212 or (NPA) 555-1212.

FILED

NOV 7 1992

EFFECTIVE:

~~October 17, 1992~~

NOV 7 1992

ISSUED:
September 17, 1992

BY: John L. Roe
Vice President - Administration
5454 West 110th Street
Overland Park, Kansas 66211

ACCESS SERVICE

2. General Regulations (Cont'd)

2.6 Definitions (Cont'd)

Directory Assistance (Intrastate)

The term "Directory Assistance" denotes the provision of telephone numbers by a Telephone Company operator when the operator location is accessed by a customer premises by sending appropriate signals, i.e. off-hook, 411, 1411, 555-1212 or (NPA) 555-1212.

Directory Assistance Location (Intrastate)

The term "Directory Assistance Location" denotes a Telephone Company office where Telephone Company equipment first receives the Directory Assistance call from a customer's premises and selects the first operator position to respond to the Directory Assistance call.

Dual Tone Multifrequency Address Signaling

The term "Dual Tone Multifrequency Address Signaling" denotes a type of signaling that is an optional feature of Switched Access Feature Group A. It may be utilized when Feature Group A is being used in the terminating direction (from the point of termination with the customer to the local exchange end office). An office arranged for Dual Tone Multi-frequency Signaling would expect to receive address signals from the customer in the form of Dual Tone Multifrequency signals.

Echo Control

The term "Echo Control" denotes the control of reflected signals in a telephone transmission path.

Echo Path Loss

The term "Echo Path Loss" denotes the measure of reflected signal at a 4-wire point of interface without regard to the send and receive Transmission Level Point.

Echo Return Loss

The term "Echo Return Loss" denotes a frequency weighted measure of return loss over the middle of the voiceband (approximately 500 to 2500 Hz), where talker echo is most annoying.

Effective 2-Wire

The term "Effective 2-Wire" denotes a condition which permits the simultaneous transmission in both directions over a channel, but it is not possible to insure independent information transmission in both directions. Effective 2-wire channels may be terminated with 2-wire or 4-wire interfaces.

(M) This material previously appeared on Page 78.

ISSUED:
May 1, 2012

Gary L. Kepley
Director - Regulatory Operations
5454 W. 110th Street
Overland Park, Kansas 66211

FILED
Missouri Public Service Commission
EFFECTIVE:
July 3, 2012
TT-2012-0317, YI-2012-0635

CANCELLED - Missouri Public Service Commission - 07/14/2023 - IN-2023-0447 - YI-2024-0001

(M)
|
(M)

ACCESS SERVICE

2. General Regulations (Cont'd)

2.6 Definitions (Cont'd)

Directory Assistance Location (Intrastate)

The term "Directory Assistance Location" denotes a Telephone Company office where Telephone Company equipment first receives the Directory Assistance call from a customer's premises and selects the first operator position to respond to the Directory Assistance call.

Dual Tone Multifrequency Address Signaling

The term "Dual Tone Multifrequency Address Signaling" denotes a type of signaling that is an optional feature of Switched Access Feature Group A. It may be utilized when Feature Group A is being used in the terminating direction (from the point of termination with the customer to the local exchange end office). An office arranged for Dual Tone Multi-frequency Signaling would expect to receive address signals from the customer in the form of Dual Tone Multifrequency signals.

Echo Control

The term "Echo Control" denotes the control of reflected signals in a telephone transmission path.

Echo Path Loss

The term "Echo Path Loss" denotes the measure of reflected signal at a 4-wire point of interface without regard to the send and receive Transmission Level Point.

Echo Return Loss

The term "Echo Return Loss" denotes a frequency weighted measure of return loss over the middle of the voiceband (approximately 500 to 2500 Hz), where talker echo is most annoying.

Effective 2-Wire

The term "Effective 2-Wire" denotes a condition which permits the simultaneous transmission in both directions over a channel, but it is not possible to insure independent information transmission in both directions. Effective 2-wire channels may be terminated with 2-wire or 4-wire interfaces.

ISSUED:
March 30, 2007

Mark D. Harper
Director - State Regulatory
5454 W. 110th Street
Overland Park, Kansas 66211

EFFECTIVE:
April 30, 2007

CANCELED
July 1, 2012
Missouri Public
Service Commission
TT-2012-0317, YI-2012-0635

Filed
Missouri Public
Service Commission

ACCESS SERVICE

RECEIVED

SEP 17 1992

2. General Regulations (Cont'd)

MISSOURI
Public Service Commission

2.6 Definitions (Cont'd)

Directory Assistance Location (Intrastate)

The term "Directory Assistance Location" denotes a Telephone Company office where Telephone Company equipment first receives the Directory Assistance call from a customer's premises and selects the first operator position to respond to the Directory Assistance call.

Dual Tone Multifrequency Address Signaling

The term "Dual Tone Multifrequency Address Signaling" denotes a type of signaling that is an optional feature of Switched Access Feature Group A. It may be utilized when Feature Group A is being used in the terminating direction (from the point of termination with the customer to the local exchange end office). An office arranged for Dual Tone Multi-frequency Signaling would expect to receive address signals from the customer in the form of Dual Tone Multifrequency signals.

Echo Control

The term "Echo Control" denotes the control of reflected signals in a telephone transmission path.

Echo Path Loss

The term "Echo Path Loss" denotes the measure of reflected signal at a 4-wire point of interface without regard to the send and receive Transmission Level Point.

Echo Return Loss

The term "Echo Return Loss" denotes a frequency weighted measure of return loss over the middle of the voiceband (approximately 500 to 2500 Hz), where talker echo is most annoying.

Effective 2-Wire

The term "Effective 2-Wire" denotes a condition which permits the simultaneous transmission in both directions over a channel, but it is not possible to insure independent information transmission in both directions. Effective 2-wire channels may be terminated with 2-wire or 4-wire interfaces.

FILED

NOV 17 1992

ISSUED:
September 17, 1992

BY: John L. Roe
Vice President - Administration
5454 West 110th Street
Overland Park, Kansas 66211

EFFECTIVE:
~~October 17, 1992~~

NOV 7 1992

ACCESS SERVICE

2. General Regulations (Cont'd)

2.6 Definitions (Cont'd)

Effective 4-Wire

The term "Effective 4-Wire" denotes a condition which permits the simultaneous independent transmission of information in both directions over a channel. The method of implementing effective 4-wire transmission is at the discretion of the Telephone Company (physical, time domain, frequency-domain separation or echo cancellation techniques). Effective 4-wire channels may be terminated with a 2-wire interface at the customer's premises. However, when terminated 2-wire, simultaneous independent transmission cannot be supported because the two wire interface combines the transmission paths into a single path.

End Office Switch

The term "End Office Switch" denotes a local Telephone Company switching system where Telephone Exchange Service customer station loops are terminated for purposes of interconnection to trunks. Included are Remote Switching Modules (RSM) and Remote Switching Systems (RSS) served by a host office in a different wire center.

End User

The term "End User" denotes any customer of an intrastate telecommunications service that is not a carrier, except that a carrier shall be deemed to be an "end user" to the extent that such carrier uses a telecommunications service for administrative purposes, without making such service available to others, directly or indirectly.

Entry Switch

See First Point of Switching.

ISSUED:
March 30, 2007

Mark D. Harper
Director - State Regulatory
5454 W. 110th Street
Overland Park, Kansas 66211

EFFECTIVE:
April 30, 2007

CANCELLED - Missouri Public Service Commission - 07/14/2023 - IN-2023-0447 - YI-2024-0001

UNITED TELEPHONE COMPANY
OF MISSOURI

Second Revised Page 80
Cancels First Revised Page 80

RECEIVED

ACCESS SERVICE

2. General Regulations (Cont'd)

MAR 27 1996

2.6 Definitions (Cont'd)

MISSOURI
PUBLIC SERVICE COMMISSION

Effective 4-Wire

The term "Effective 4-Wire" denotes a condition which permits the simultaneous independent transmission of information in both directions over a channel. The method of implementing effective 4-wire transmission is at the discretion of the Telephone Company (physical, time domain, frequency-domain separation or echo cancellation techniques). Effective 4-wire channels may be terminated with a 2-wire interface at the customer's premises. However, when terminated 2-wire, simultaneous independent transmission cannot be supported because the two wire interface combines the transmission paths into a single path.

(M)
|
(M)

End Office Switch

The term "End Office Switch" denotes a local Telephone Company switching system where Telephone Exchange Service customer station loops are terminated for purposes of interconnection to trunks. Included are Remote Switching Modules (RSM) and Remote Switching Systems (RSS) served by a host office in a different wire center.

End User

The term "End User" denotes any customer of an intrastate telecommunications service that is not a carrier, except that a carrier shall be deemed to be an "end user" to the extent that such carrier uses a telecommunications service for administrative purposes, without making such service available to others, directly or indirectly.

Entry Switch

See First Point of Switching.

MAR 27 1996

ISSUED:
March 27, 1996

BY: John L. Roe
Vice President - Carrier and Regulatory Services
5454 West 110th Street
Overland Park, Kansas 66211

EFFECTIVE:
April 29, 1996

ACCESS SERVICE

2. General Regulations (Cont'd)

RECEIVED

2.6 Definitions (Cont'd)

MAR 31 1993

Effective 4-Wire

MO. PUBLIC SERVICE COMMISSION

The term "Effective 4-Wire" denotes a condition which permits the simultaneous independent transmission of information in both directions over a channel. The method of implementing effective 4-wire transmission is at the discretion of the Telephone Company (physical, time domain, frequency-domain separation or echo cancellation techniques). Effective 4-wire channels may be terminated with a 2-wire interface at the customer's premises. However, when terminated 2-wire, simultaneous independent transmission cannot be supported because the two wire interface combines the transmission paths into a single path.

800 Service Management System

The term "800 Service Management System" (800 SMS) denotes the main operations support system used to create and update 800 service records in the national 800 data base.

800 Service Provider

The term "800 Service Provider" denotes a telecommunications company, including local exchange carriers and interexchange carriers, or a reseller of exchange or interexchange services that offers 800 service to end users.

End Office Switch

The term "End Office Switch" denotes a local Telephone Company switching system where Telephone Exchange Service customer lines are terminated for purposes of interconnection to trunks. Included are Remote Switching Modules (RSM) and Remote Switching Systems (RSS) served by a host office in a different wire center.

End User

The term "End User" denotes any customer of an intrastate telecommunications service that is not a carrier, except that a carrier shall be deemed to be an "end user" to the extent that such carrier uses a telecommunications service for administrative purposes, without making such service available to others, directly or indirectly.

Entry Switch

See First Point of Switching.

MAY 01 1993

MO. PUBLIC SERVICE COMMISSION

ISSUED:
March 31, 1993

BY: John L. Roe
Vice President - Administration
5454 West 110th Street
Overland Park, Kansas 66211

EFFECTIVE:
May 1, 1993

(N)
|
(N)

CANCELLED
APR 29 1995
BY 2nd R.S. # 80
Public Service Commission
MISSOURI

ACCESS SERVICE

RECEIVED

2. General Regulations (Cont'd)

SEP 17 1992

2.6 Definitions (Cont'd)

MISSOURI
Public Service Commission

Effective 4-Wire

The term "Effective 4-Wire" denotes a condition which permits the simultaneous independent transmission of information in both directions over a channel. The method of implementing effective 4-wire transmission is at the discretion of the Telephone Company (physical, time domain, frequency-domain separation or echo cancellation techniques). Effective 4-wire channels may be terminated with a 2-wire interface at the customer's premises. However, when terminated 2-wire, simultaneous independent transmission cannot be supported because the two wire interface combines the transmission paths into a single path.

End Office Switch

The term "End Office Switch" denotes a local Telephone Company switching system where Telephone Exchange Service customer station loops are terminated for purposes of interconnection to trunks. Included are Remote Switching Modules (RSM) and Remote Switching Systems (RSS) served by a host office in a different wire center.

End User

The term "End User" denotes any customer of an intrastate telecommunications service that is not a carrier, except that a carrier shall be deemed to be an "end user" to the extent that such carrier uses a telecommunications service for administrative purposes, without making such service available to others, directly or indirectly.

Entry Switch

See First Point of Switching.

Envelope Delay Distortion

The term "Envelope Delay Distortion" denotes a measure of the linearity of the phase versus frequency of a channel.

CANCELLED

MAY 1 1993

BY 1st R.S. 80

Public Service Commission
MISSOURI

FILED

NOV 7 1992

MO. PUBLIC SERVICE COMMISSION

EFFECTIVE:

~~SEP 17, 1992~~

NOV 7 1992

ISSUED:
September 17, 1992

BY: John L. Roe
Vice President - Administration
5454 West 110th Street
Overland Park, Kansas 66211

ACCESS SERVICE

2. General Regulations (Cont'd)

2.6 Definitions (Cont'd)

Envelope Delay Distortion

The term "Envelope Delay Distortion" denotes a measure of the linearity of the phase versus frequency of a channel.

Equal Access End User Restriction Service

The term "Equal Access End User Restriction Service" denotes a service offering whereby an end user's ability to access the facilities of an Interexchange Carrier (IC) may be restricted at the request of the IC.

Equal Level Echo Path Loss

The term "Equal Level Echo Path Loss" (ELEPL) denotes the measure of Echo Path Loss (EPL) at a 4-wire interface which is corrected by the difference between the send and receive Transmission Level Point (TLP) [ELEPL = EPL - TLP (send) + TLP (receive)].

Exchange

The term "Exchange" denotes a unit generally smaller than a local access and transport area, established by the Telephone Company for the administration of communications service in a specified area which usually embraces a city, town or village and its environs. It consists of one or more central offices together with the associated facilities used in furnishing communications service within that area. One or more designated exchanges comprise a given local access and transport area.

Expected Measured Loss

The term "Expected Measured Loss" denotes a calculated loss which specifies the end-to-end 1004-Hz loss on a terminated test connection between two readily accessible manual or remote test points. It is the sum of the inserted connection loss and test access loss including any test pads.

Field Identifier

The term "Field Identifiers" denotes two to four characters that are used on service orders to convey specific instructions. Field Identifiers may or may not have associated data. Selected field identifiers are used in telephone Company billing systems to generate nonrecurring charges.

ISSUED:
March 30, 2007

Mark D. Harper
Director - State Regulatory
5454 W. 110th Street
Overland Park, Kansas 66211

EFFECTIVE:
April 30, 2007

CANCELLED - Missouri Public Service Commission - 07/14/2023 - IN-2023-0447 - YI-2024-0001

ACCESS SERVICE

2. General Regulations (Cont'd)

2.6 Definitions (Cont'd)

Envelope Delay Distortion

The term "Envelope Delay Distortion" denotes a measure of the linearity of the phase versus frequency of a channel.

Equal Access End User Restriction Service

The term "Equal Access End User Restriction Service" denotes a service offering whereby an end user's ability to access the facilities of an Interexchange Carrier (IC) may be restricted at the request of the IC.

Equal Level Echo Path Loss

The term "Equal Level Echo Path Loss" (ELEPL) denotes the measure of Echo Path Loss (EPL) at a 4-wire interface which is corrected by the difference between the send and receive Transmission Level Point (TLP). [ELEPL = EPL - TLP (send) + TLP (receive)].

Exchange

The term "Exchange" denotes a unit generally smaller than a local access and transport area, established by the Telephone Company for the administration of communications service in a specified area which usually embraces a city, town or village and its environs. It consists of one or more central offices together with the associated facilities used in furnishing communications service within that area. One or more designated exchanges comprise a given local access and transport area.

Expected Measured Loss

The term "Expected Measured Loss" denotes a calculated loss which specifies the end-to-end 1004-Hz loss on a terminated test connection between two readily accessible manual or remote test points. It is the sum of the inserted connection loss and test access loss including any test pads.

Field Identifier

The term "Field Identifiers" denotes two to four characters that are used on service orders to convey specific instructions. Field Identifiers may or may not have associated data. Selected field identifiers are used in Telephone Company billing systems to generate nonrecurring charges.

ISSUED:
March 31, 1993

BY: John L. Roe
Vice President - Administration
5454 West 110th Street
Overland Park, Kansas 66211

EFFECTIVE:
May 1, 1993

UNITED TELEPHONE COMPANY
OF MISSOURI

Original Page 81

RECEIVED

SEP 17 1992

ACCESS SERVICE

MISSOURI
Public Service Commission

2. General Regulations (Cont'd)

2.6 Definitions (Cont'd)

Equal Access End User Restriction Service

The term "Equal Access End User Restriction Service" denotes a service offering whereby an end user's ability to access the facilities of an Interexchange Carrier (IC) may be restricted at the request of the IC.

Equal Level Echo Path Loss

The term "Equal Level Echo Path Loss" (ELEPL) denotes the measure of Echo Path Loss (EPL) at a 4-wire interface which is corrected by the difference between the send and receive Transmission Level Point (TLP). [ELEPL = EPL - TLP (send) + TLP (receive)].

Exchange

The term "Exchange" denotes a unit generally smaller than a local access and transport area, established by the Telephone Company for the administration of communications service in a specified area which usually embraces a city, town or village and its environs. It consists of one or more central offices together with the associated facilities used in furnishing communications service within that area. One or more designated exchanges comprise a given local access and transport area.

Expected Measured Loss

The term "Expected Measured Loss" denotes a calculated loss which specifies the end-to-end 1004-Hz loss on a terminated test connection between two readily accessible manual or remote test points. It is the sum of the inserted connection loss and test access loss including any test pads.

Field Identifier

The term "Field Identifiers" denotes two to four characters that are used on service orders to convey specific instructions. Field Identifiers may or may not have associated data. Selected field identifiers are used in Telephone Company billing systems to generate nonrecurring charges.

CANCELLED

MAY 1 1993
BY Let R.S. #81
Public Service Commission
MISSOURI

FILED

NOV 7 1992

MO. PUBLIC SERVICE COMMISSION

ISSUED:
September 17, 1992

BY: John L. Roe
Vice President - Administration
5454 West 110th Street
Overland Park, Kansas 66211

EFFECTIVE:
~~October 17, 1992~~
NOV 7 1992

ACCESS SERVICE

2. General Regulations (Cont'd)

2.6 Definitions (Cont'd)

First-Come, First-Served

The term "First-Come, First-Served" denotes a procedure followed when the first service order received will be the first service order processed.

First Point of Switching

The term "First Point of Switching" denotes the first Telephone Company location at which switching occurs on the terminating path of a call proceeding from the customer premises to the terminating end office and, at the same time, the last Telephone Company location at which switching occurs on the originating path of a call proceeding from the originating end office to the customer premises.

Frequency Shift

The term "Frequency Shift" denotes the change in the frequency of a tone as it is transmitted over a channel.

Geographically Aggregated Rate (GAR)

The term "Geographically Aggregated Rate" denotes a situation in which the rates and charges for a service offering, for which there is currently no demand, are developed based upon the aggregated total revenue and demand for more than one study area. Upon receipt of a request for service, the current geographically averaged rates will be redeveloped to include the new study area.

Example: Study areas A, B, and C have been geographically aggregated. Geographically averaged rates for A and B were developed based on their aggregated total revenue and demand, while Area C, marked "GAR", has no current demand. Should C receive a request for service, the current geographically averaged rates will be redeveloped to include C's revenue and demand. The redeveloped rates and charges will now be applicable to customers in A, B, and C.

Grandfathered

The term "Grandfathered" denotes Terminal Equipment, Multiline Terminating Systems Protective Circuitry directly connected to the facilities utilized to provide services under the provisions of this tariff, and which are considered grandfathered under Part 68 of the FCC's Rules and Regulations.

Host Office

The term "Host Office" denotes an electronic switching system which provides call processing capabilities for one or more Remote Switching Modules or Remote Switching Systems.

(N)

(N)

(M) Material omitted from this page now appears on Page 83.

ISSUED:
May 1, 2013

Gary L. Kepley
Director - Regulatory Operations
5454 W. 110th Street
Overland Park, Kansas 66211

EFFECTIVE:
July 2, 2013

(M)

(M)

ACCESS SERVICE

2. General Regulations (Cont'd)

2.6 Definitions (Cont'd)

First-Come, First-Served

The term "First-Come, First-Served" denotes a procedure followed when the first service order received will be the first service order processed.

First Point of Switching

The term "First Point of Switching" denotes the first Telephone Company location at which switching occurs on the terminating path of a call proceeding from the customer premises to the terminating end office and, at the same time, the last Telephone Company location at which switching occurs on the originating path of a call proceeding from the originating end office to the customer premises.

Frequency Shift

The term "Frequency Shift" denotes the change in the frequency of a tone as it is transmitted over a channel.

Grandfathered

The term "Grandfathered" denotes Terminal Equipment, Multiline Terminating Systems Protective Circuitry directly connected to the facilities utilized to provide services under the provisions of this tariff, and which are considered grandfathered under Part 68 of the FCC's Rules and Regulations.

Host Office

The term "Host Office" denotes an electronic switching system which provides call processing capabilities for one or more Remote Switching Modules or Remote Switching Systems.

Hub

A Hub is a Telephone Company designated serving wire center at which bridging or multiplexing functions are performed. The bridging functions performed may be used to connect three or more Customer designated premises in a multipoint arrangement. The multiplexing functions are to channelize analog or digital facilities to individual services requiring a lower capacity or bandwidth.

(N)
|
(N)
|
(M)
|
(M)

(M) Material omitted from this page now appears on Page 83.

ISSUED:
May 1, 2012

Gary L. Kepley
Director - Regulatory Operations
5454 W. 110th Street
Overland Park, Kansas 66211

FILED EFFECTIVE:
Missouri Public July 3, 2012
Service Commission
TT-2012-0317, YI-2012-0635

ACCESS SERVICE

2. General Regulations (Cont'd)

2.6 Definitions (Cont'd)

First-Come, First-Served

The term "First-Come, First-Served" denotes a procedure followed when the first service order received will be the first service order processed.

First Point of Switching

The term "First Point of Switching" denotes the first Telephone Company location at which switching occurs on the terminating path of a call proceeding from the customer premises to the terminating end office and, at the same time, the last Telephone Company location at which switching occurs on the originating path of a call proceeding from the originating end office to the customer premises.

Frequency Shift

The term "Frequency Shift" denotes the change in the frequency of a tone as it is transmitted over a channel.

Grandfathered

The term "Grandfathered" denotes Terminal Equipment, Multiline Terminating Systems Protective Circuitry directly connected to the facilities utilized to provide services under the provisions of this tariff, and which are considered grandfathered under Part 68 of the FCC's Rules and Regulations.

Host Office

The term "Host Office" denotes an electronic switching system which provides call processing capabilities for one or more Remote Switching Modules or Remote Switching Systems.

ICB

See Individual Case Basis

Immediately Available Funds

The term "Immediately Available Funds" denotes a corporate or personal check drawn on a bank account and funds which are available for use by the receiving party on the same day on which they are received and includes U.S. Federal Reserve bank wire transfers, U.S. Federal Reserve notes (paper cash), U.S. coins, U.S. Postal Money Orders and New York Certificates of Deposit.

ISSUED:
March 30, 2007

Mark D. Harper
Director - State Regulatory
5454 W. 110th Street
Overland Park, Kansas 66211

EFFECTIVE:
April 30, 2007

CANCELED
July 1, 2012
Missouri Public
Service Commission
TT-2012-0317, YI-2012-0635

Filed
Missouri Public
Service Commission

UNITED TELEPHONE COMPANY
OF MISSOURI

Original Page 82

RECEIVED

SEP 17 1992

MISSOURI
Public Service Commission

ACCESS SERVICE

2. General Regulations (Cont'd)2.6 Definitions (Cont'd)First-Come, First-Served

The term "First-Come, First-Served" denotes a procedure followed when the first service order received will be the first service order processed.

First Point of Switching

The term "First Point of Switching" denotes the first Telephone Company location at which switching occurs on the terminating path of a call proceeding from the customer premises to the terminating end office and, at the same time, the last Telephone Company location at which switching occurs on the originating path of a call proceeding from the originating end office to the customer premises.

Frequency Shift

The term "Frequency Shift" denotes the change in the frequency of a tone as it is transmitted over a channel.

Grandfathered

The term "Grandfathered" denotes Terminal Equipment, Multiline Terminating Systems Protective Circuitry directly connected to the facilities utilized to provide services under the provisions of this tariff, and which are considered grandfathered under Part 68 of the F.C.C.'s Rules and Regulations.

Host Office

The term "Host Office" denotes an electronic switching system which provides call processing capabilities for one or more Remote Switching Modules or Remote Switching Systems.

ICB

See Individual Case Basis

Immediately Available Funds

The term "Immediately Available Funds" denotes a corporate or personal check drawn on a bank account and funds which are available for use by the receiving party on the same day on which they are received and includes U.S. Federal Reserve bank wire transfers, U.S. Federal Reserve notes (paper cash), U.S. coins, U.S. Postal Money Orders and New York Certificates of Deposit.

ISSUED:
September 17, 1992

BY: John L. Roe
Vice President - Administration
5454 West 110th Street
Overland Park, Kansas 66211

EFFECTIVE:
~~October 17, 1992~~
NOV 7 1992

Cancelled

April 30, 2007
Missouri Public
Service Commission

ACCESS SERVICE

2. General Regulations (Cont'd)

2.6 Definitions (Cont'd)

Hub

A Hub is a Telephone Company designated serving wire center at which bridging or multiplexing functions are performed. The bridging functions performed may be used to connect three or more Customer designated premises in a multipoint arrangement. The multiplexing functions are to channelize analog or digital facilities to individual services requiring a lower capacity or bandwidth.

(M)
—
(M)

ICB

See Individual Case Basis

Immediately Available Funds

The term "Immediately Available Funds" denotes a corporate or personal check drawn on a bank account and funds which are available for use by the receiving party on the same day on which they are received and includes U.S. Federal Reserve bank wire transfers, U.S. Federal Reserve notes (paper cash), U.S. coins, U.S. Postal Money Orders and New York Certificates of Deposit.

Impedance Balance

The term "Impedance Balance" denotes the method of expressing Echo Return Loss and Singing Return Loss at a 4-wire interface whereby the gains and/or loss of the 4 wire portion of the transmission path, including the hybrid, are not included in the specification.

Impulse Noise

The term "Impulse Noise" denotes any momentary occurrence of the noise on a channel over a specified level threshold. It is evaluated by counting the number of occurrences which exceed the threshold.

Individual Case Basis

The term "Individual Case Basis" denotes a condition in which the regulations, if applicable, rates and charges for an offering under the provisions of this tariff are developed based on the circumstances in each case.

Inserted Connection Loss

The term "Inserted Connection Loss" denotes the 1004 Hz power difference (in dBs) between the maximum power available at the originating end and the actual power reaching the terminating end through the inserted connection.

Interexchange Carrier (IC) or Interexchange Common Carrier

The terms "Interexchange Carrier" (IC) or "Interexchange Common Carrier" denotes any individual, partnership, association, joint-stock company, trust, governmental entity or corporation engaged for hire in intrastate communication by wire or radio, between two or more exchanges, whether on their own facilities or by reselling the facilities or service of others.

(M) This material previously appeared on Page 82.

ISSUED:
May 1, 2013

Gary L. Kepley
Director - Regulatory Operations
5454 W. 110th Street
Overland Park, Kansas 66211

EFFECTIVE:
July 2, 2013

ACCESS SERVICE

2. General Regulations (Cont'd)

2.6 Definitions (Cont'd)

ICB

See Individual Case Basis

Immediately Available Funds

The term "Immediately Available Funds" denotes a corporate or personal check drawn on a bank account and funds which are available for use by the receiving party on the same day on which they are received and includes U.S. Federal Reserve bank wire transfers, U.S. Federal Reserve notes (paper cash), U.S. coins, U.S. Postal Money Orders and New York Certificates of Deposit.

Impedance Balance

The term "Impedance Balance" denotes the method of expressing Echo Return Loss and Singing Return Loss at a 4-wire interface whereby the gains and/or loss of the 4 wire portion of the transmission path, including the hybrid, are not included in the specification.

Impulse Noise

The term "Impulse Noise" denotes any momentary occurrence of the noise on a channel over a specified level threshold. It is evaluated by counting the number of occurrences which exceed the threshold.

Individual Case Basis

The term "Individual Case Basis" denotes a condition in which the regulations, if applicable, rates and charges for an offering under the provisions of this tariff are developed based on the circumstances in each case.

Inserted Connection Loss

The term "Inserted Connection Loss" denotes the 1004 Hz power difference (in dBs) between the maximum power available at the originating end and the actual power reaching the terminating end through the inserted connection.

Interexchange Carrier (IC) or Interexchange Common Carrier

The terms "Interexchange Carrier" (IC) or "Interexchange Common Carrier" denotes any individual, partnership, association, joint-stock company, trust, governmental entity or corporation engaged for hire in intrastate communication by wire or radio, between two or more exchanges, whether on their own facilities or by reselling the facilities or service of others.

(M)

(M)

(M1)

(M1)

(M) This material previously appeared on Page 82.

(M1) Material omitted from this page now appears on Page 84.

ISSUED:
May 1, 2012

Gary L. Kepley
Director - Regulatory Operations
5454 W. 110th Street
Overland Park, Kansas 66211

EFFECTIVE:
July 3, 2012

FILED
Missouri Public
Service Commission
TT-2012-0317, YI-2012-0635

ACCESS SERVICE

2. General Regulations (Cont'd)

2.6 Definitions (Cont'd)

Impedance Balance

The term "Impedance Balance" denotes the method of expressing Echo Return Loss and Singing Return Loss at a 4-wire interface whereby the gains and/or loss of the 4 wire portion of the transmission path, including the hybrid, are not included in the specification.

Impulse Noise

The term "Impulse Noise" denotes any momentary occurrence of the noise on a channel over a specified level threshold. It is evaluated by counting the number of occurrences which exceed the threshold.

Individual Case Basis

The term "Individual Case Basis" denotes a condition in which the regulations, if applicable, rates and charges for an offering under the provisions of this tariff are developed based on the circumstances in each case.

Inserted Connection Loss

The term "Inserted Connection Loss" denotes the 1004 Hz power difference (in dBs) between the maximum power available at the originating end and the actual power reaching the terminating end through the inserted connection.

Interexchange Carrier (IC) or Interexchange Common Carrier

The terms "Interexchange Carrier" (IC) or "Interexchange Common Carrier" denotes any individual, partnership, association, joint-stock company, trust, governmental entity or corporation engaged for hire in intrastate communication by wire or radio, between two or more exchanges, whether on their own facilities or by reselling the facilities or service of others.

Intermodulation Distortion

The term "Intermodulation Distortion" denotes a measure of the non-linearity of a channel. It is measured using four tones, and evaluating the ratios (in dBs) of the transmitted composite four-tone signal power to the second-order products of the tones (R2), and the third-order products of the tones (R3).

ISSUED:
March 30, 2007

Mark D. Harper
Director - State Regulatory
5454 W. 110th Street
Overland Park, Kansas 66211

EFFECTIVE:
April 30, 2007

CANCELED
July 1, 2012
Missouri Public
Service Commission
TT-2012-0317, YI-2012-0635

Filed
Missouri Public
Service Commission

UNITED TELEPHONE COMPANY
OF MISSOURI

Original Page 83

ACCESS SERVICE

RECEIVED

2. General Regulations (Cont'd)

SEP 17 1992

2.6 Definitions (Cont'd)

MISSOURI
Public Service Commission

Impedance Balance

The term "Impedance Balance" denotes the method of expressing Echo Return Loss and Singing Return Loss at a 4-wire interface whereby the gains and/or loss of the 4 wire portion of the transmission path, including the hybrid, are not included in the specification.

Impulse Noise

The term "Impulse Noise" denotes any momentary occurrence of the noise on a channel over a specified level threshold. It is evaluated by counting the number of occurrences which exceed the threshold.

Individual Case Basis

The term "Individual Case Basis" denotes a condition in which the regulations, if applicable, rates and charges for an offering under the provisions of this tariff are developed based on the circumstances in each case.

Inserted Connection Loss

The term "Inserted Connection Loss" denotes the 1004 Hz power difference (in dBs) between the maximum power available at the originating end and the actual power reaching the terminating end through the inserted connection.

Interexchange Carrier (IC) or Interexchange Common Carrier

The terms "Interexchange Carrier" (IC) or "Interexchange Common Carrier" denotes any individual, partnership, association, joint-stock company, trust, governmental entity or corporation engaged for hire in intrastate communication by wire or radio, between two or more exchanges, whether on their own facilities or by reselling the facilities or service of others.

Intermodulation Distortion

The term "Intermodulation Distortion" denotes a measure of the non-linearity of a channel. It is measured using four tones, and evaluating the ratios (in dBs) of the transmitted composite four-tone signal power to the second-order products of the tones (R2), and the third-order products of the tones (R3).

NOV 7 1992

ISSUED:
September 17, 1992

BY: John L. Roe
Vice President - Administration
5454 West 110th Street
Overland Park, Kansas 66211

MO. P. S. C. 8-27224

EFFECTIVE:

~~September 17, 1992~~
NOV 7 1992

ACCESS SERVICE

2. General Regulations (Cont'd)

2.6 Definitions (Cont'd)

Intermodulation Distortion

The term "Intermodulation Distortion" denotes a measure of the non-linearity of a channel. It is measured using four tones, and evaluating the ratios (in dBs) of the transmitted composite four-tone signal power to the second-order products of the tones (R2), and the third-order products of the tones (R3).

(M)

(M)

Intrastate Communications

The term "Intrastate Communications" denotes any communications within a state subject to oversight by a state regulatory commission as provided by the laws of the state involved.

Jointly Provided WATS Service

Jointly provided WATS Service is an arrangement between the Telephone Company and as interexchange customer (IC). This arrangement provides end user billing of intraLATA WATS/TFC usage at the intraLATA WATS/TFC rates filed by or concurred in by the Telephone Company.

Kilobits Per Second (Kbps)

One thousand bits per second.

(N)

(N)

Line Information Data Base

The Line Information Data Base (LIDB) is a data base containing billing validation data to support Alternate Billing Services.

Line Side Connection

The term "Line Side Connection" denotes a connection of a transmission path to the line side of a local exchange switching system.

Local Access and Transport Area (LATA)

The term "Local Access and Transport Area" denotes a geographic area established for the provision and administration of communications service. It encompasses one or more designated exchanges, which are grouped to serve common social, economic and other purposes. For the purposes of this tariff Geographical Market Area (GMA) and LATA are intended to be interchangeable.

(M) This material previously appeared on Page 83.

ISSUED:
May 1, 2012

Gary L. Kepley
Director - Regulatory Operations
5454 W. 110th Street
Overland Park, Kansas 66211

EFFECTIVE:
July 3, 2012

FILED
Missouri Public
Service Commission
TT-2012-0317, YI-2012-0635

CANCELLED - Missouri Public Service Commission - 07/14/2023 - IN-2023-0447 - YI-2024-0001

ACCESS SERVICE

2. General Regulations (Cont'd)

2.6 Definitions (Cont'd)

Intrastate Communications

The term "Intrastate Communications" denotes any communications within a state subject to oversight by a state regulatory commission as provided by the laws of the state involved.

Jointly Provided WATS Service

Jointly provided WATS Service is an arrangement between the Telephone Company and as interexchange customer (IC). This arrangement provides end user billing of intraLATA WATS/TFC usage at the intraLATA WATS/TFC rates filed by or concurred in by the Telephone Company.

Line Information Data Base

The Line Information Data Base (LIDB) is a data base containing billing validation data to support Alternate Billing Services.

Line Side Connection

The term "Line Side Connection" denotes a connection of a transmission path to the line side of a local exchange switching system.

Local Access and Transport Area (LATA)

The term "Local Access and Transport Area" denotes a geographic area established for the provision and administration of communications service. It encompasses one or more designated exchanges, which are grouped to serve common social, economic and other purposes. For the purposes of this tariff Geographical Market Area (GMA) and LATA are intended to be interchangeable.

ISSUED:
March 30, 2007

Mark D. Harper
Director - State Regulatory
5454 W. 110th Street
Overland Park, Kansas 66211

EFFECTIVE:
April 30, 2007

CANCELED
July 1, 2012
Missouri Public
Service Commission
TT-2012-0317, YI-2012-0635

UNITED TELEPHONE COMPANY
OF MISSOURI

Second Revised Page 84
Cancels First Revised Page 84

ACCESS SERVICE

REGULATORY

2. General Regulations (Cont'd)

2.6 Definitions (Cont'd)

MISSOURI

Intrastate Communications

The term "Intrastate Communications" denotes any communications within a state subject to oversight by a state regulatory commission as provided by the laws of the state involved.

MISSOURI
Public Service Commission

Jointly Provided WATS Service

Jointly provided WATS Service is an arrangement between the Telephone Company and as interexchange customer (IC). This arrangement provides end user billing of intraLATA WATS/TFC usage at the intraLATA WATS/TFC rates filed by or concurred in by the Telephone Company.

(T)
(T)

Line Information Data Base

The Line Information Data Base (LIDB) is a data base containing billing validation data to support Alternate Billing Services.

Line Side Connection

The term "Line Side Connection" denotes a connection of a transmission path to the line side of a local exchange switching system.

Local Access and Transport Area (LATA)

The term "Local Access and Transport Area" denotes a geographic area established for the provision and administration of communications service. It encompasses one or more designated exchanges, which are grouped to serve common social, economic and other purposes. For the purposes of this tariff Geographical Market Area (GMA) and LATA are intended to be interchangeable.

ISSUED
MARCH 27 1996
MISSOURI
PUBLIC SERVICE COMMISSION

ISSUED:
March 27, 1996

BY: John L. Roe
Vice President - Carrier and Regulatory Services
5454 West 110th Street
Overland Park, Kansas 66211

EFFECTIVE:
April 29, 1996

UNITED TELEPHONE COMPANY
OF MISSOURI

First Revised Page 84
Cancels Original Page 84

ACCESS SERVICE

RECEIVED

2. General Regulations (Cont'd)

DEC 23 1993

2.6 Definitions (Cont'd)

MISSOURI
Public Service Commission

Intrastate Communications

The term "Intrastate Communications" denotes any communications within a state subject to oversight by a state regulatory commission as provided by the laws of the state involved.

Jointly Provided WATS Service

Jointly provided WATS Service is an arrangement between the Telephone Company and as interexchange customer (IC). This arrangement provides end user billing of intraLATA WATS/800 usage at the intraLATA WATS/800 rates filed by or concurred in by the Telephone Company.

Line Information Data Base

The Line Information Data Base (LIDB) is a data base containing billing validation data to support Alternate Billing Services.

Line Side Connection

The term "Line Side Connection" denotes a connection of a transmission path to the line side of a local exchange switching system.

Local Access and Transport Area (LATA)

The term "Local Access and Transport Area" denotes a geographic area established for the provision and administration of communications service. It encompasses one or more designated exchanges, which are grouped to serve common social, economic and other purposes. For the purposes of this tariff Geographical Market Area (GMA) and LATA are intended to be interchangeable.

CANCELLED

APR 29 1996
BY J. R. S. # 84
Public Service Commission
MISSOURI

FILED

JAN 24 1994

MISSOURI
Public Service Commission

ISSUE DATE:
December 23, 1993

BY: John L. Roe
Vice President - Administration
5454 West 110th Street
Overland Park, Kansas 66211

EFFECTIVE DATE:
January 24, 1994

(N)
|
(N)
|
(M)
|
(M)

UNITED TELEPHONE COMPANY
OF MISSOURI

Original Page 84

ACCESS SERVICE

2. General Regulations (Cont'd)

2.6 Definitions (Cont'd)

Intrastate Communications

The term "Intrastate Communications" denotes any communications within a state subject to oversight by a state regulatory commission as provided by the laws of the state involved.

Jointly Provided WATS Service

Jointly provided WATS Service is an arrangement between the Telephone Company and as interexchange customer (IC). This arrangement provides end user billing of intraLATA WATS/800 usage at the intraLATA WATS/800 rates filed by or concurred in by the Telephone Company.

Line Side Connection

The term "Line Side Connection" denotes a connection of a transmission path to the line side of a local exchange switching system.

Local Access and Transport Area (LATA)

The term "Local Access and Transport Area" denotes a geographic area established for the provision and administration of communications service. It encompasses one or more designated exchanges, which are grouped to serve common social, economic and other purposes. For the purposes of this tariff Geographical Market Area (GMA) and LATA are intended to be interchangeable.

RECEIVED

SEP 17 1992

MISSOURI
Public Service Commission

CANCELLED

JAN 24 1994

BY 1st P.S. #84
Public Service Commission
MISSOURI

FILED

NOV 7 1992

MO. PUBLIC SERVICE COMMISSION

EFFECTIVE:

~~October 27, 1992~~

NOV 7 1992

ISSUED:
September 17, 1992

BY: John L. Roe
Vice President - Administration
5454 West 110th Street
Overland Park, Kansas 66211

ACCESS SERVICE

2. General Regulations (Cont'd)

2.6 Definitions (Cont'd)

Local Calling Area

The term "Local Calling Area" denotes a geographical area, as defined in the Telephone Company's Local and/or General Exchange Service tariff, in which an end user (Telephone Exchange Service subscriber) may complete a call without incurring MTS charges.

Local Exchange Carriers (LECs)

The terms "Local Exchange Carrier" denotes the certificated provider of basic local exchange telephone service.

Local Tandem Switch

The term "Local Tandem Switch" denotes a local Telephone Company switching unit by which local or access telephonic communications are switched to and from an End Office Switch.

Loop Around Test Line

The term "Loop Around Test Line" denotes an arrangement utilizing a Telephone Company central office to provide a means to make certain two-way transmission tests on a manual basis. This arrangement has two central office terminations, each reached by means of separate telephone numbers and does not require any specific customer premises equipment. Equipment subject to this test arrangement is at the discretion of the customer.

Loss Deviation

The term "Loss Deviation" denotes the variation of the actual loss from the designed value.

Major Fraction Thereof

The term "Major Fraction Thereof" is any period of time in excess of 1/2 of the stated amount of time. As an example, in considering a period of 24 hours, a major fraction thereof would be any period of time in excess of 12 hours exactly. Therefore, if a given service is interrupted for a period of thirty six hours and fifteen minutes, the customer would be given a credit allowance for two twenty-four hour periods for a total of forty eight hours.

Message

The term "Message" denotes a "call" as defined preceding.

ISSUED:
March 30, 2007

Mark D. Harper
Director - State Regulatory
5454 W. 110th Street
Overland Park, Kansas 66211

EFFECTIVE:
April 30, 2007

CANCELLED - Missouri Public Service Commission - 07/14/2023 - IN-2023-0447 - YI-2024-0001

UNITED TELEPHONE COMPANY
OF MISSOURI

Original Page 85

ACCESS SERVICE

RECEIVED

2. General Regulations (Cont'd)

SEP 17 1992

2.6 Definitions (Cont'd)

MISSOURI
Public Service Commission

Local Calling Area

The term "Local Calling Area" denotes a geographical area, as defined in the Telephone Company's Local and/or General Exchange Service tariff, in which an end user (Telephone Exchange Service subscriber) may complete a call without incurring MTS charges.

Local Exchange Carriers (LECs)

The terms "Local Exchange Carrier" denotes the certificated provider of basic local exchange telephone service.

Local Tandem Switch

The term "Local Tandem Switch" denotes a local Telephone Company switching unit by which local or access telephonic communications are switched to and from an End Office Switch.

Loop Around Test Line

The term "Loop Around Test Line" denotes an arrangement utilizing a Telephone Company central office to provide a means to make certain two-way transmission tests on a manual basis. This arrangement has two central office terminations, each reached by means of separate telephone numbers and does not require any specific customer premises equipment. Equipment subject to this test arrangement is at the discretion of the customer.

Loss Deviation

The term "Loss Deviation" denotes the variation of the actual loss from the designed value.

Major Fraction Thereof

The term "Major Fraction Thereof" is any period of time in excess of 1/2 of the stated amount of time. As an example, in considering a period of 24 hours, a major fraction thereof would be any period of time in excess of 12 hours exactly. Therefore, if a given service is interrupted for a period of thirty six hours and fifteen minutes, the customer would be given a credit allowance for two twenty four hour periods for a total of forty eight hours.

Message

The term "Message" denotes a "call" as defined preceding

NOV 7 1992

MS. PUBLIC SERVICE COMM.

ISSUED:
September 17, 1992

BY: John L. Roe
Vice President - Administration
5454 West 110th Street
Overland Park, Kansas 66211

EFFECTIVE:
~~October 14, 1992~~
NOV 7 1992

ACCESS SERVICE

2. General Regulations (Cont'd)

2.6 Definitions (Cont'd)

Milliwatt (102 Type) Test Line

The term "Milliwatt (102 Type) Test Line" denotes an arrangement in an end office which provides a 1004 Hz tone at 0 dBm0 for one-way transmission measurements towards the customer's premises from the Telephone Company end office.

Minutes of Use

See Access Minutes

Network Control Signaling

The term "Network Control Signaling" denotes the transmission of signals used in the telecommunications system which perform functions such as supervision (control, status, and charge signals), address signaling (e.g., dialing), calling and called number identifications, rate of flow, service selection error control and audible tone signals (call progress signals indicating reorder or busy conditions, alerting, coin denominations, coin collect and coin return tones) to control the operation of the telecommunications system.

Network Data Report

Interexchange customers (ICs) providing TFC service jointly with the Telephone Company must provide to the Telephone Company a TFC Network Data Report. This report shall reflect all TFC telephone numbers that may originate and terminate in the same state within Telephone Company territory. Each TFC telephone number provided in the TFC Network Data Report will reflect a ten digits POTS telephone number (for calls completing on joint provided WATS Access Line Service) to which the TFC Access Service traffic will complete. This report shall also reflect any time or day sensitive routing information which the Telephone company requires to accurately bill and an indicator of the type of termination that will be used in the completion of the TFC call, i.e., common line, WATS Access Line, or other. The IC is required to provide this report before initial TFC Access Service is established. The IC is required to provide an updated TFC Network Data Report on a weekly basis unless the Telephone Company and the IC agree that the ICs TFC service activity requires provision of the report on either a more frequent or less frequent basis.

Non-Jointly Provided WATS Service

At the option of the interexchange customer (IC) providing interLATA service to the end user, the IC may choose to not jointly provide WATS Service with the Telephone Company. If the WATS Service is not jointly provided, the Telephone Company will bill long distance message rates for intraLATA calls originated on interLATA-only WATS Access Lines.

(M)
|
(M)

(M) – Material moved from Page 87.

ISSUED:
May 14, 2021

Chantel Bosworth
Director - Government Operations
100 CenturyLink Dr.
Monroe, LA 71203

EFFECTIVE:
July 1, 2021

MO2021-06

FILED
Missouri Public
Service Commission
JI-2021-0199

CANCELLED - Missouri Public Service Commission - 07/14/2023 - IN-2023-0447 - YI-2024-0001

ACCESS SERVICE

2. General Regulations (Cont'd)

2.6 Definitions (Cont'd)

Milliwatt (102 Type) Test Line

The term "Milliwatt (102 Type) Test Line" denotes an arrangement in an end office which provides a 1004 Hz tone at 0 dBm0 for one-way transmission measurements towards the customer's premises from the Telephone Company end office.

Minutes of Use

See Access Minutes

Network Control Signaling

The term "Network Control Signaling" denotes the transmission of signals used in the telecommunications system which perform functions such as supervision (control, status, and charge signals), address signaling (e.g., dialing), calling and called number identifications, rate of flow, service selection error control and audible tone signals (call progress signals indicating reorder or busy conditions, alerting, coin denominations, coin collect and coin return tones) to control the operation of the telecommunications system.

Network Data Report

Interexchange customers (ICs) providing TFC service jointly with the Telephone Company must provide to the Telephone Company a TFC Network Data Report. This report shall reflect all TFC telephone numbers that may originate and terminate in the same state within Telephone Company territory. Each TFC telephone number provided in the TFC Network Data Report will reflect a ten digits POTS telephone number (for calls completing on joint provided WATS Access Line Service) to which the TFC Access Service traffic will complete. This report shall also reflect any time or day sensitive routing information which the Telephone company requires to accurately bill and an indicator of the type of termination that will be used in the completion of the TFC call, i.e., common line, WATS Access Line, or other. The IC is required to provide this report before initial TFC Access Service is established. The IC is required to provide an updated TFC Network Data Report on a weekly basis unless the Telephone Company and the IC agree that the ICs TFC service activity requires provision of the report on either a more frequent or less frequent basis.

(N)
|
(N)

ISSUED:
May 1, 2012

Gary L. Kepley
Director - Regulatory Operations
5454 W. 110th Street
Overland Park, Kansas 66211

FILED
Missouri Public
Service Commission
TT-2012-0317, YI-2012-0635

EFFECTIVE:
July 3, 2012

CANCELLED
July 1, 2021
Missouri Public
Service Commission
JI-2021-0199

ACCESS SERVICE

2. General Regulations (Cont'd)

2.6 Definitions (Cont'd)

Milliwatt (102 Type) Test Line

The term "Milliwatt (102 Type) Test Line" denotes an arrangement in an end office which provides a 1004 Hz tone at 0 dBm0 for one-way transmission measurements towards the customer's premises from the Telephone Company end office.

Network Control Signaling

The term "Network Control Signaling" denotes the transmission of signals used in the telecommunications system which perform functions such as supervision (control, status, and charge signals), address signaling (e.g., dialing), calling and called number identifications, rate of flow, service selection error control and audible tone signals (call progress signals indicating reorder or busy conditions, alerting, coin denominations, coin collect and coin return tones) to control the operation of the telecommunications system.

Network Data Report

Interexchange customers (ICs) providing TFC service jointly with the Telephone Company must provide to the Telephone Company a TFC Network Data Report. This report shall reflect all TFC telephone numbers that may originate and terminate in the same state within Telephone Company territory. Each TFC telephone number provided in the TFC Network Data Report will reflect a ten digits POTS telephone number (for calls completing on joint provided WATS Access Line Service) to which the TFC Access Service traffic will complete. This report shall also reflect any time or day sensitive routing information which the Telephone company requires to accurately bill and an indicator of the type of termination that will be used in the completion of the TFC call, i.e., common line, WATS Access Line, or other. The IC is required to provide this report before initial TFC Access Service is established. The IC is required to provide an updated TFC Network Data Report on a weekly basis unless the Telephone Company and the IC agree that the ICs TFC service activity requires provision of the report on either a more frequent or less frequent basis.

ISSUED:
March 30, 2007

Mark D. Harper
Director - State Regulatory
5454 W. 110th Street
Overland Park, Kansas 66211

EFFECTIVE:
April 30, 2007

CANCELED
July 1, 2012
Missouri Public
Service Commission
TT-2012-0317, YI-2012-0635

UNITED TELEPHONE COMPANY
OF MISSOURI

First Revised Page 86
Cancels Original Page 86

RECEIVED

ACCESS SERVICE

2. General Regulations (Cont'd)

MAR 27 1996

2.6 Definitions (Cont'd)

MISSOURI
Public Service Commission

Milliwatt (102 Type) Test Line

The term "Milliwatt (102 Type) Test Line" denotes an arrangement in an end office which provides a 1004 Hz tone at 0 dBm0 for one-way transmission measurements towards the customer's premises from the Telephone Company end office.

Network Control Signaling

The term "Network Control Signaling" denotes the transmission of signals used in the telecommunications system which perform functions such as supervision (control, status, and charge signals), address signaling (e.g., dialing), calling and called number identifications, rate of flow, service selection error control and audible tone signals (call progress signals indicating reorder or busy conditions, alerting, coin denominations, coin collect and coin return tones) to control the operation of the telecommunications system.

Network Data Report

Interexchange customers (ICs) providing TFC service jointly with the Telephone Company must provide to the Telephone Company a TFC Network Data Report. This report shall reflect all TFC telephone numbers that may originate and terminate in the same state within Telephone Company territory. Each TFC telephone number provided in the TFC Network Data Report will reflect a ten digits POTS telephone number (for calls completing on joint provided WATS Access Line Service) to which the TFC Access Service traffic will complete. This report shall also reflect any time or day sensitive routing information which the Telephone company requires to accurately bill and an indicator of the type of termination that will be used in the completion of the TFC call, i.e., common line, WATS Access Line, or other. The IC is required to provide this report before initial TFC Access Service is established. The IC is required to provide an updated TFC Network Data Report on a weekly basis unless the Telephone Company and the IC agree that the ICs TFC service activity requires provision of the report on either a more frequent or less frequent basis. (T)

ISSUED:
March 27, 1996

BY: John L. Roe
Vice President - Carrier and Regulatory Services
5454 West 110th Street
Overland Park, Kansas 66211

EFFECTIVE:
April 29, 1996

UNITED TELEPHONE COMPANY
OF MISSOURI

Original Page 86

ACCESS SERVICE

RECEIVED

SEP 17 1992

2. General Regulations (Cont'd)

MISSOURI
Public Service Commission

2.6 Definitions (Cont'd)

Milliwatt (102 Type) Test Line

The term "Milliwatt (102 Type) Test Line" denotes an arrangement in an end office which provides a 1004 Hz tone at 0 dBm0 for one-way transmission measurements towards the customer's premises from the Telephone Company end office.

Network Control Signaling

The term "Network Control Signaling" denotes the transmission of signals used in the telecommunications system which perform functions such as supervision (control, status, and charge signals), address signaling (e.g., dialing), calling and called number identifications, rate of flow, service selection error control and audible tone signals (call progress signals indicating reorder or busy conditions, alerting, coin denominations, coin collect and coin return tones) to control the operation of the telecommunications system.

Network Data Report

Interexchange customers (ICs) providing 800 service jointly with the Telephone Company must provide to the Telephone Company an 800 Network Data Report. This report shall reflect all 800 telephone numbers that may originate and terminate in the same state within Telephone Company territory. Each 800 telephone number provided in the 800 Network Data Report will reflect a ten digits POTS telephone number (for calls completing on joint provided WATS Access Line Service) to which the 800 Access Service traffic will complete. This report shall also reflect any time or day sensitive routing information which the Telephone company requires to accurately bill and an indicator of the type of termination that will be used in the completion of the 800 call, i.e., common line, WATS Access Line, or other. The IC is required to provide this report before initial 800 Access Service is established. The IC is required to provide an updated 800 Network Data Report on a weekly basis unless the Telephone Company and the IC agree that the ICs 800 service activity requires provision of the report on either a more frequent or less frequent basis.

CANCELLED

APR 29 1995
BY *John L. Roe*
Public Service Commission
MISSOURI

FILED

NOV 7 1992

ISSUED:
September 17, 1992

BY: John L. Roe
Vice President - Administration
5454 West 110th Street
Overland Park, Kansas 66211

MISSOURI PUBLIC SERVICE COMMISSION
EFFECTIVE DATE: 9/17/92

NOV 7 1992

ACCESS SERVICE

2. General Regulations (Cont'd)

2.6 Definitions (Cont'd)

(M)

Nonsynchronous Test Line

The term "Nonsynchronous Test Line" denotes an arrangement in step-by-step end offices which provides operational tests which are not as complete as those provided by the synchronous test lines, but can be made more rapidly.

Non-Toll Free

All calls that are not toll free (8YY) as established by the FCC's 8YY Access Charge Reform Order (FCC 20-143) released on October 9, 2020.

(N)

(N)

North American Numbering Plan

The term "North American Numbering Plan" denotes a three-digit area (Numbering Plan Area) code and a seven-digit telephone number made up of a three-digit Central Office code plus a four-digit station number.

Off-hook

The term "Off-hook" denotes the active condition of Switched Access or a Telephone Exchange Service line.

On-hook

The term "On-hook" denotes the idle condition of Switched Access or a Telephone Exchange Service line.

Open Circuit Test Line

The term "Open Circuit Test Line" denotes an arrangement in an end office which provides an ac open circuit termination of a trunk or line by means of an inductor of several Henries.

Optical Carrier Level (n) (OC n)

The term "Optical Carrier Level (n)" denotes the physical line connection (aka facility) between two locations that uses optical signaling equipment for transmitting information over fiber optics. A level of bit rate speed transmission is indicated by "n". OC1 optical transmissions are at 51.84 Mbps; OC3 at 155.52 Mbps; OC12 at 622.08 Mbps; and OC48 at 2488.32 Mbps.

(M) – Material moved to Page 86.

ISSUED:
May 14, 2021

Chantel Bosworth
Director - Government Operations
100 CenturyLink Dr.
Monroe, LA 71203

EFFECTIVE:
July 1, 2021

MO2021-06

FILED
Missouri Public
Service Commission
JI-2021-0199

CANCELLED - Missouri Public Service Commission - 07/14/2023 - IN-2023-0447 - YI-2024-0001

ACCESS SERVICE

2. General Regulations (Cont'd)

2.6 Definitions (Cont'd)

Non-Jointly Provided WATS Service

At the option of the interexchange customer (IC) providing interLATA service to the end user, the IC may choose to not jointly provide WATS Service with the Telephone Company. If the WATS Service is not jointly provided, the Telephone Company will bill long distance message rates for intraLATA calls originated on interLATA-only WATS Access Lines.

Nonsynchronous Test Line

The term "Nonsynchronous Test Line" denotes an arrangement in step-by-step end offices which provides operational tests which are not as complete as those provided by the synchronous test lines, but can be made more rapidly.

North American Numbering Plan

The term "North American Numbering Plan" denotes a three-digit area (Numbering Plan Area) code and a seven-digit telephone number made up of a three-digit Central Office code plus a four-digit station number.

Off-hook

The term "Off-hook" denotes the active condition of Switched Access or a Telephone Exchange Service line.

On-hook

The term "On-hook" denotes the idle condition of Switched Access or a Telephone Exchange Service line.

Open Circuit Test Line

The term "Open Circuit Test Line" denotes an arrangement in an end office which provides an ac open circuit termination of a trunk or line by means of an inductor of several Henries.

Optical Carrier Level (n) (OC n)

The term "Optical Carrier Level (n)" denotes the physical line connection (aka facility) between two locations that uses optical signaling equipment for transmitting information over fiber optics. A level of bit rate speed transmission is indicated by "n". OC1 optical transmissions are at 51.84 Mbps; OC3 at 155.52 Mbps; OC12 at 622.08 Mbps; and OC48 at 2488.32 Mbps.

(N)
|
(N)

ISSUED:
May 1, 2012

Gary L. Kepley
Director - Regulatory Operations
5454 W. 110th Street
Overland Park, Kansas 66211

FILED
Missouri Public
Service Commission
TT-2012-0317, YI-2012-0635

EFFECTIVE:
July 3, 2012

CANCELLED
July 1, 2021
Missouri Public
Service Commission
JI-2021-0199

ACCESS SERVICE

2. General Regulations (Cont'd)

2.6 Definitions (Cont'd)

Non-Jointly Provided WATS Service

At the option of the interexchange customer (IC) providing interLATA service to the end user, the IC may choose to not jointly provide WATS Service with the Telephone Company. If the WATS Service is not jointly provided, the Telephone Company will bill long distance message rates for intraLATA calls originated on interLATA-only WATS Access Lines.

Nonsynchronous Test Line

The term "Nonsynchronous Test Line" denotes an arrangement in step-by-step end offices which provides operational tests which are not as complete as those provided by the synchronous test lines, but can be made more rapidly.

North American Numbering Plan

The term "North American Numbering Plan" denotes a three-digit area (Numbering Plan Area) code and a seven-digit telephone number made up of a three-digit Central Office code plus a four-digit station number.

Off-hook

The term "Off-hook" denotes the active condition of Switched Access or a Telephone Exchange Service line.

On-hook

The term "On-hook" denotes the idle condition of Switched Access or a Telephone Exchange Service line.

Open Circuit Test Line

The term "Open Circuit Test Line" denotes an arrangement in an end office which provides an ac open circuit termination of a trunk or line by means of an inductor of several Henries.

ISSUED:
March 30, 2007

Mark D. Harper
Director - State Regulatory
5454 W. 110th Street
Overland Park, Kansas 66211

EFFECTIVE:
April 30, 2007

CANCELED
July 1, 2012
Missouri Public
Service Commission
TT-2012-0317, YI-2012-0635

Filed
Missouri Public
Service Commission

ACCESS SERVICE

RECEIVED

SEP 17 1992

2. General Regulations (Cont'd)

2.6 Definitions (Cont'd)

Non-Jointly Provided WATS Service

At the option of the interexchange customer (IC) providing interLATA service to the end user, the IC may choose to not jointly provide WATS Service with the Telephone Company. If the WATS Service is not jointly provided, the Telephone Company will bill long distance message rates for intraLATA calls originated on interLATA-only WATS Access Lines.

Nonsynchronous Test Line

The term "Nonsynchronous Test Line" denotes an arrangement in step-by-step end offices which provides operational tests which are not as complete as those provided by the synchronous test lines, but can be made more rapidly.

North American Numbering Plan

The term "North American Numbering Plan" denotes a three-digit area (Numbering Plan Area) code and a seven-digit telephone number made up of a three-digit Central Office code plus a four-digit station number.

Off-hook

The term "Off-hook" denotes the active condition of Switched Access or a Telephone Exchange Service line.

On-hook

The term "On-hook" denotes the idle condition of Switched Access or a Telephone Exchange Service line.

Open Circuit Test Line

The term "Open Circuit Test Line" denotes an arrangement in an end office which provides an ac open circuit termination of a trunk or line by means of an inductor of several Henries.

NOV 7 1992

ISSUED:
September 17, 1992

BY: John L. Roe
Vice President - Administration
5454 West 110th Street
Overland Park, Kansas 66211

EFFECTIVE:
~~October 19, 1992~~
NOV 7 1992

ACCESS SERVICE

2. General Regulations (Cont'd)

2.6 Definitions (Cont'd)

Optical Carrier Level n Concatenated (OCnc)

The term "Optical Carrier Level n Concatenated" denotes the physical line or clear channel connection (aka facility) between two locations that is capable, using optical signaling equipment, of replacing multiple payload groupings into one larger payload grouping, resulting in a single communications channel.

(N)

Optical Carrier Rate (OC#)

The term "Optical Carrier Rate" denotes a SONET transmission signal/speed, line rate or service. The rate is in multiples of an OC1, which is equivalent to a Synchronous Transport Signal (STS1), 51.84 Mbps, SONET's basic rate. OC# rate bandwidth capacity is 155.52 Mbps for OC3, 622.08 Mbps for OC12, and 2488.32 Mbps for OC48.

(N)

Originating Direction

The term "Originating Direction" denotes the use of Access Service for the origination of calls from an end user premises to a customer premises.

Overlap Outpulsing

The feature of the exchange access signaling system which permits initiation of pulsing to the customer's premises before the calling subscriber has completed dialing an originating call.

(N)

(N)

Pay Telephone

The term "Pay Telephone" denotes coin or coinless instruments and related facilities that are available to the general public for public convenience and necessity.

Phase Jitter

The term "Phase Jitter" denotes the unwanted phase variations of a signal.

Point of Termination

The term "Point of Termination" denotes a point of demarcation within a customer-designated premises at which the Telephone Company's responsibility for the provision of Access Service ends.

(M)

(M)

(M) Material omitted from this page now appears on Page 89.

ISSUED:
May 1, 2012

Gary L. Kepley
Director - Regulatory Operations
5454 W. 110th Street
Overland Park, Kansas 66211

FILED
Missouri Public Service Commission
EFFECTIVE:
July 3, 2012
TT-2012-0317, YI-2012-0635

CANCELLED - Missouri Public Service Commission - 07/14/2023 - IN-2023-0447 - YI-2024-0001

ACCESS SERVICE

2. General Regulations (Cont'd)

2.6 Definitions (Cont'd)

Originating Direction

The term "Originating Direction" denotes the use of Access Service for the origination of calls from an end user premises to a customer premises.

Pay Telephone

The term "Pay Telephone" denotes coin or coinless instruments and related facilities that are available to the general public for public convenience and necessity.

Phase Jitter

The term "Phase Jitter" denotes the unwanted phase variations of a signal.

Point of Termination

The term "Point of Termination" denotes a point of demarcation within a customer-designated premises at which the Telephone Company's responsibility for the provision of Access Service ends.

Premises

The term "Premises" denotes a building, or a portion of a building in a multitenant building, or buildings on continuous property (except Railroad Right-of-Way, etc.), not separated by a public highway.

Primary Toll Carrier

The following telephone companies are the Primary Toll Carriers, (all of which are Local Exchange Carriers) for intraLATA service under the Missouri Primary Carrier by Toll Center Plan filed with and as subsequently modified by the Commission: Fidelity, Contel, GTE North, Southwestern Bell and United Telephone.

Query

A query is a request for specific information generated by a computer processor and sent to a data base, with a predefined set of responses expected.

ISSUED:
March 30, 2007

Mark D. Harper
Director - State Regulatory
5454 W. 110th Street
Overland Park, Kansas 66211

EFFECTIVE:
April 30, 2007

CANCELED
July 1, 2012
Missouri Public
Service Commission
TT-2012-0317, YI-2012-0635

Filed
Missouri Public
Service Commission

UNITED TELEPHONE COMPANY
OF MISSOURI d/b/a SPRINT

Second Revised Page 88
Cancels First Revised Page 88

RECEIVED

ACCESS SERVICE

2. General Regulations (Cont'd)

JAN 15 1997

2.6 Definitions (Cont'd)

MISSOURI
Public Service Commission

Originating Direction

The term "Originating Direction" denotes the use of Access Service for the origination of calls from an end user premises to a customer premises.

Pay Telephone

The term "Pay Telephone" denotes coin or coinless instruments and related facilities that are available to the general public for public convenience and necessity. (T) (D)

Phase Jitter

The term "Phase Jitter" denotes the unwanted phase variations of a signal.

Point of Termination

The term "Point of Termination" denotes a point of demarcation within a customer-designated premises at which the Telephone Company's responsibility for the provision of Access Service ends.

Premises

The term "Premises" denotes a building, or a portion of a building in a multitenant building, or buildings on continuous property (except Railroad Right-of-Way, etc.), not separated by a public highway.

Primary Toll Carrier

The following telephone companies are the Primary Toll Carriers, (all of which are Local Exchange Carriers) for intraLATA service under the Missouri Primary Carrier by Toll Center Plan filed with and as subsequently modified by the Commission: Fidelity, Contel, GTE North, Southwestern Bell and United Telephone. FILED

Query

A query is a request for specific information generated by a computer processor and sent to a data base, with a predefined set of responses expected.

APR 15 1997

NO POSTER RECORD

EFFECTIVE:

APR 15 1997

ISSUED:
January 15, 1997

BY: John L. Roe
VP - Carrier and Regulatory Services
5454 West 110th Street
Overland Park, Kansas 66211

ACCESS SERVICE

RECEIVED

MAR 31 1993

MO. PUBLIC SERVICE COMM.

2. General Regulations (Cont'd)

2.6 Definitions (Cont'd)

Originating Direction

The term "Originating Direction" denotes the use of Access Service for the origination of calls from an end user premises to a customer premises.

Pay Telephone

The term "Pay Telephone" denotes Telephone Company provided instruments and related facilities that are available to the general public for public convenience and necessity, including public and semipublic telephones, and coinless telephones.

Phase Jitter

The term "Phase Jitter" denotes the unwanted phase variations of signal.

Point of Termination

The term "Point of Termination" denotes a point of demarcation within a customer-designated premises at which the Telephone Company's responsibility for the provision of Access Service ends.

Premises

The term "Premises" denotes a building, or a portion of a building in a multitenant building, or buildings on continuous property (except Railroad Right-of-Way, etc.), not separated by a public highway.

Primary Toll Carrier

The following telephone companies are the Primary Toll Carriers, (all of which are Local Exchange Carriers) for intraLATA service under the Missouri Primary Carrier by Toll Center Plan filed with and as subsequently modified by the Commission: Fidelity, Contel, GTE North, Southwestern Bell and United Telephone.

Query

A query is a request for specific information generated by a computer processor and sent to a data base, with a predefined set of responses expected.

CANCELLED
APR 15 1993
BY 2 R.S. # 88
Public Service Commission
MISSOURI

MAY 0 1 1993

MO. PUBLIC SERVICE COMM.

ISSUED:
March 31, 1993

BY: John L. Roe
Vice President - Administration
5454 West 110th Street
Overland Park, Kansas 66211

EFFECTIVE:
May 1, 1993

(N)
|
(N)

ACCESS SERVICE

RECEIVED

2. General Regulations (Cont'd)

SEP 17 1992

2.6 Definitions (Cont'd)

MISSOURI
Public Service Commission

Originating Direction

The term "Originating Direction" denotes the use of Access Service for the origination of calls from an end user premises to a customer premises.

Pay Telephone

The term "Pay Telephone" denotes Telephone Company provided instruments and related facilities that are available to the general public for public convenience and necessity, including public and semipublic telephones, and coinless telephones.

Phase Jitter

The term "Phase Jitter" denotes the unwanted phase variations in a signal.

CANCELLED

MAY 1 1993
BY let R.S. #88
Public Service Commission
MISSOURI

Point of Termination

The term "Point of Termination" denotes a point of demarcation within a customer-designated premises at which the Telephone Company's responsibility for the provision of Access Service ends.

Premises

The term "Premises" denotes a building, or a portion of a building in a multitenant building, or buildings on continuous property (except Railroad Right-of-Way, etc.), not separated by a public highway.

Primary Toll Carrier

The following telephone companies are the Primary Toll Carriers, (all of which are Local Exchange Carriers) for intraLATA service under the Missouri Primary Carrier by Toll Center Plan filed with and as subsequently modified by the Commission: Fidelity, Contel, GTE North, Southwestern Bell and United Telephone.

Remote Switching Modules and/or Remote Switching Systems

The term "Remote Switching Modules and/or Remote Switching Systems" denotes small, remotely controlled electronic end office switches which obtain their call processing capability from an ESS-type Host Office. The Remote Switching Modules and/or Remote Switching Systems cannot accommodate direct trunks to a customer.

ISSUED:
September 17, 1992

BY: John L. Roe
Vice President - Administration
5454 West 110th Street
Overland Park, Kansas 66211

NO. PUBLIC SERVICE COMMISSION

EFFECTIVE:
~~October 27, 1992~~
NOV 7 1992

ACCESS SERVICE

2. General Regulations (Cont'd)

2.6 Definitions (Cont'd)

Premises

The term "Premises" denotes a building, or a portion of a building in a multitenant building, or buildings on continuous property (except Railroad Right-of-Way, etc.), not separated by a public highway.

Primary Toll Carrier

The following telephone companies are the Primary Toll Carriers, (all of which are Local Exchange Carriers) for intraLATA service under the Missouri Primary Carrier by Toll Center Plan filed with and as subsequently modified by the Commission: Fidelity, Contel, GTE North, Southwestern Bell and United Telephone.

Query

A query is a request for specific information generated by a computer processor and sent to a data base, with a predefined set of responses expected.

Registered Equipment

The term "Registered Equipment" denotes the customer's premises equipment which complies with and has been approved within the Registration Provisions of Part 68 of the FCC's Rules and Regulations.

Remote Switching Modules and/or Remote Switching Systems

The term "Remote Switching Modules and/or Remote Switching Systems" denotes small, remotely controlled electronic end office switches which obtain their call processing capability from an ESS-type Host Office. The Remote Switching Modules and/or Remote Switching Systems cannot accommodate direct trunks to a customer.

Responsible Organization

The term "Responsible Organization" denotes that entity which is responsible for the management and administration of a TFC service record in the TFC Service Management System.

Return Loss

The term "Return Loss" denotes a measure of the similarity between the two impedances at the junction of two transmission paths. The higher the return loss, the higher the similarity.

(M)

(M)

(M1)

(M1)

(M) This material previously appeared on Page 88.

(M1) Material omitted from this page now appears on Page 89.1.

ISSUED:
May 1, 2012

Gary L. Kepley
Director - Regulatory Operations
5454 W. 110th Street
Overland Park, Kansas 66211

FILED
Missouri Public
Service Commission
EFFECTIVE:
July 3, 2012
TT-2012-0317, YI-2012-0635

CANCELLED - Missouri Public Service Commission - 07/14/2023 - IN-2023-0447 - YI-2024-0001

ACCESS SERVICE

2. General Regulations (Cont'd)

2.6 Definitions (Cont'd)

Registered Equipment

The term "Registered Equipment" denotes the customer's premises equipment which complies with and has been approved within the Registration Provisions of Part 68 of the FCC's Rules and Regulations.

Remote Switching Modules and/or Remote Switching Systems

The term "Remote Switching Modules and/or Remote Switching Systems" denotes small, remotely controlled electronic end office switches which obtain their call processing capability from an ESS-type Host Office. The Remote Switching Modules and/or Remote Switching Systems cannot accommodate direct trunks to a customer.

Responsible Organization

The term "Responsible Organization" denotes that entity which is responsible for the management and administration of a TFC service record in the TFC Service Management System.

Return Loss

The term "Return Loss" denotes a measure of the similarity between the two impedances at the junction of two transmission paths. The higher the return loss, the higher the similarity.

Secondary Carrier

Secondary Carrier (SC): A Local Exchange Carrier that does not function as a toll carrier, is compensated for those services provided to Primary Toll Carriers, does not establish toll rates or retain toll revenues and bill end users for intraLATA toll calls at the rates the respective PTC sets.

Service Control Point

A Service Control Point (SCP) is a transaction processor based system that provides a network interface to various data base services.

ISSUED:
March 30, 2007

Mark D. Harper
Director - State Regulatory
5454 W. 110th Street
Overland Park, Kansas 66211

EFFECTIVE:
April 30, 2007

CANCELED
July 1, 2012
Missouri Public
Service Commission
TT-2012-0317, YI-2012-0635

Filed
Missouri Public
Service Commission

UNITED TELEPHONE COMPANY
OF MISSOURI

Second Revised Page 89
Cancels First Revised Page 89

RECEIVED

ACCESS SERVICE

2. General Regulations (Cont'd)

APR 27 1996

2.6 Definitions (Cont'd)

MISSOURI
Public Service Commission

Registered Equipment

The term "Registered Equipment" denotes the customer's premises equipment which complies with and has been approved within the Registration Provisions of Part 68 of the F.C.C.'s Rules and Regulations.

Remote Switching Modules and/or Remote Switching Systems

The term "Remote Switching Modules and/or Remote Switching Systems" denotes small, remotely controlled electronic end office switches which obtain their call processing capability from an ESS-type Host Office. The Remote Switching Modules and/or Remote Switching Systems cannot accommodate direct trunks to a customer.

Responsible Organization

The term "Responsible Organization" denotes that entity which is responsible for the management and administration of a TFC service record in the TFC Service Management System.

(T)
(T)

Return Loss

The term "Return Loss" denotes a measure of the similarity between the two impedances at the junction of two transmission paths. The higher the return loss, the higher the similarity.

Secondary Carrier

Secondary Carrier (SC): A Local Exchange Carrier that does not function as a toll carrier, is compensated for those services provided to Primary Toll Carriers, does not establish toll rates or retain toll revenues and bill end users for intraLATA toll calls at the rates the respective PTC sets.

Service Control Point

A Service Control Point (SCP) is a transaction processor based system that provides a network interface to various data base services.

RECEIVED

APR 23 1996

ISSUED:
March 27, 1996

BY: John L. Roe
Vice President - Carrier and Regulatory Services
5454 West 110th Street
Overland Park, Kansas 66211

EFFECTIVE:
April 29, 1996

Cancelled
April 30, 2007
Missouri Public
Service Commission

ACCESS SERVICE

REQUIRED

MAR 31 1993

MO. PUBLIC SERVICE COM. D.

2. General Regulations (Cont'd)

2.6 Definitions (Cont'd)

Registered Equipment

The term "Registered Equipment" denotes the customer's premises equipment which complies with and has been approved within the Registration Provisions of Part 68 of the F.C.C.'s Rules and Regulations.

Remote Switching Modules and/or Remote Switching Systems

The term "Remote Switching Modules and/or Remote Switching Systems" denotes small, remotely controlled electronic end office switches which obtain their call processing capability from an ESS-type Host Office. The Remote Switching Modules and/or Remote Switching Systems cannot accommodate direct trunks to a customer.

Responsible Organization

The term "Responsible Organization" denotes that entity which is responsible for the management and administration of an 800 service record in the 800 Service Management System.

Return Loss

The term "Return Loss" denotes a measure of the similarity between the two impedances at the junction of two transmission paths. The higher the return loss, the higher the similarity.

Secondary Carrier

Secondary Carrier (SC): A Local Exchange Carrier that does not function as a toll carrier, is compensated for those services provided to Primary Toll Carriers, does not establish toll rates or retain toll revenues and bill end users for intraLATA toll calls at the rates the respective PTC sets.

Service Control Point

A Service Control Point (SCP) is a translation processor based system that provides a network interface to various data base services.

CANCELLED
APR 29 1995
BY 2nd R.S. #89
Public Service Commission
MISSOURI

MAY 01 1993

MO. PUBLIC SERVICE COM. D.

ISSUED:
March 31, 1993

BY: John L. Roe
Vice President - Administration
5454 West 110th Street
Overland Park, Kansas 66211

EFFECTIVE:
May 1, 1993

(M)
(M)
(N)
(N)
(M)
(M)
(N)
(N)

ACCESS SERVICE

RECEIVED

SEP 17 1992

2. General Regulations (Cont'd)

2.6 Definitions (Cont'd)

MISSOURI
Public Service Commission

Return Loss

The term "Return Loss" denotes a measure of the similarity between the two impedances at the junction of two transmission paths. The higher the return loss, the higher the similarity.

Registered Equipment

The term "Registered Equipment" denotes the customer's premises equipment which complies with and has been approved within the Registration Provisions of Part 68 of the F.C.C.'s Rules and Regulations.

Secondary Carrier

Secondary Carrier (SC): A Local Exchange Carrier that does not function as a toll carrier, is compensated for those services provided to Primary Toll Carriers, does not establish toll rates or retain toll revenues and bill end users for intraLATA toll calls at the rates the respective PTC sets.

Seven Digit Manual Test Line

The term "Seven Digit Manual Test Line" denotes an arrangement which allows the customer to select balance, milliwatt and synchronous test lines by manually dialing a seven digit number over the associated access connection.

CANCELLED

MAY 1 1993

BY 1st R.S. # 89

Public Service Commission

Short Circuit Test Line

The term "Short Circuit Test Line" denotes an arrangement in an end office which provides for an ac short circuit termination on a trunk or line by means of a capacitor of at least four microfarads.

Signal-to-C-Notched Noise Ratio

The term "Signal-to-C-Notched Noise Ratio" denotes the ratio in dB of a test signal to the corresponding C-Notched Noise.

FILED

NOV 7 1992

MISSOURI PUBLIC SERVICE COMMISSION

ISSUED:
September 17, 1992

BY: John L. Roe
Vice President - Administration
5454 West 110th Street
Overland Park, Kansas 66211

EFFECTIVE:
~~October 17, 1992~~
NOV 7 1992

ACCESS SERVICE

2. General Regulations (Cont'd)

2.6 Definitions (Cont'd)

Secondary Carrier

Secondary Carrier (SC): A Local Exchange Carrier that does not function as a toll carrier, is compensated for those services provided to Primary Toll Carriers, does not establish toll rates or retain toll revenues and bill end users for intraLATA toll calls at the rates the respective PTC sets.

Service Control Point

A Service Control Point (SCP) is a transaction processor based system that provides a network interface to various data base services.

Service Switching Point

An end office or tandem switch equipped with the signaling link hardware and software that can perform the Signal Point functions. In addition, SSPs can identify the need for application software in processing a Common Channel Signaling/ Signaling System 7 call and request and respond to call processing instructions issued by a Service Control Point.

Seven Digit Manual Test Line

The term "Seven Digit Manual Test Line" denotes an arrangement which allows the customer to select balance, milliwatt and synchronous test lines by manually dialing a seven digit number over the associated access connection.

Short Circuit Test Line

The term "Short Circuit Test Line" denotes an arrangement in an end office which provides for an ac short circuit termination of a trunk or line by means of a capacitor of at least four microfarads.

Signal-to-C-Notched Noise Ratio

The term "Signal-to-C-Notched Noise Ratio" denotes the ratio in dB of a test signal to the corresponding C-Notched Noise.

Signal Transfer Point (STP)

The term "Signal Transfer Point" denotes a packet switch which provides CCS network access and performs CCS message routing and screening.

(M)

(M)

(M1)

(M1)

(M) This material previously appeared on Page 89.

(M1) This material previously appeared on Page 90.

ISSUED:
May 1, 2012

Gary L. Kepley
Director - Regulatory Operations
5454 W. 110th Street
Overland Park, Kansas 66211

FILED EFFECTIVE:
Missouri Public July 3, 2012
Service Commission
TT-2012-0317, YI-2012-0635

CANCELLED - Missouri Public Service Commission - 07/14/2023 - IN-2023-0447 - YI-2024-0001

ACCESS SERVICE

2. General Regulations (Cont'd)

2.6 Definitions (Cont'd)

Service Switching Point

An end office or tandem switch equipped with the signaling link hardware and software that can perform the Signal Point functions. In addition, SSPs can identify the need for application software in processing a Common Channel Signaling/ Signaling System 7 call and request and respond to call processing instructions issued by a Service Control Point.

Seven Digit Manual Test Line

The term "Seven Digit Manual Test Line" denotes an arrangement which allows the customer to select balance, milliwatt and synchronous test lines by manually dialing a seven digit number over the associated access connection.

Short Circuit Test Line

The term "Short Circuit Test Line" denotes an arrangement in an end office which provides for an ac short circuit termination of a trunk or line by means of a capacitor of at least four microfarads.

Signal-to-C-Notched Noise Ratio

The term "Signal-to-C-Notched Noise Ratio" denotes the ratio in dB of a test signal to the corresponding C-Notched Noise.

ISSUED:
March 30, 2007

Mark D. Harper
Director - State Regulatory
5454 W. 110th Street
Overland Park, Kansas 66211

EFFECTIVE:
April 30, 2007

CANCELED
July 1, 2012
Missouri Public
Service Commission
TT-2012-0317, YI-2012-0635

Filed
Missouri Public
Service Commission

ACCESS SERVICE

2. General Regulations (Cont'd)

2.6 Definitions (Cont'd)

Service Switching Point

An end office or tandem switch equipped with the signaling link hardware and software that can perform the Signal Point functions. In addition, SSPs can identify the need for application software in processing a Common Channel Signaling/Signaling System 7 call and request and respond to call rprocessing instructions issued by a Service Control Point.

Seven Digit Manual Test Line

The term "Seven Digit Manual Test Line" denotes an arrangement which allows the customer to select balance, milliwatt and synchronous test lines by manually dialing a seven digit number over the associated access connection.

Short Circuit Test Line

The term "Short Circuit Test Line" denotes an arrangement in an end office which provides for an ac short circuit termination of a trunk or line by means of a capacitor of at least four microfarads.

Signal-to-C-Notched Noise Ratio

The term "Signal-to-C-Notched Noise Ratio" denotes the ratio in dB of a test signal to the corresponding C-Notched Noise.

ISSUED:
March 31, 1993

BY: John L. Roe
Vice President - Administration
5454 West 110th Street
Overland Park, Kansas 66211

EFFECTIVE:
May 1, 1993

ACCESS SERVICE

2. General Regulations (Cont'd)

2.6 Definitions (Cont'd)

Singing Return Loss

The term "Singing Return Loss" denotes the frequency weighted measure of return loss at the edges of the voiceband (200 to 500 Hz and 2500 to 3200 Hz), where singing (instability) problems are most likely to occur.

Special Order

The term "Special Order" denotes an order for a Billing and Collection Service or an order for a Directory Assistance Service.

Subtending End Office of an Access Tandem

The term "Subtending End Office of an Access Tandem" denotes an end office that has final trunk group routing through that tandem.

Synchronous Test Line

The term "Synchronous Test Line" denotes an arrangement in an end office which performs marginal operational tests of supervisory and ring-tripping functions.

Tandem-Switched Transport

The term "Tandem-Switched Transport" denotes switched access transport from the access tandem to an end office subtending that tandem. Tandem-switched transport consists of circuits used in common by multiple access customers from the tandem to the end office.

Terminating Direction

The term "Terminating Direction" denotes the use of Access Service for the completion of calls from a customer premises to an end user premises.

(M)

(M)

(N)

(N)

(M1)

(M1)

(M) Material omitted from this page now appears on Page 89.1.

(M1) Material omitted from this page now appears on Page 90.1.

ISSUED:
May 1, 2012

Gary L. Kepley
Director - Regulatory Operations
5454 W. 110th Street
Overland Park, Kansas 66211

FILED
Missouri Public
Service Commission
TT-2012-0317, YI-2012-0635

EFFECTIVE:
July 3, 2012

CANCELLED - Missouri Public Service Commission - 07/14/2023 - IN-2023-0447 - YI-2024-0001

ACCESS SERVICE

2. General Regulations (Cont'd)

2.6 Definitions (Cont'd)

Signal Transfer Point (STP)

The term "Signal Transfer Point" denotes a packet switch which provides CCS network access and performs CCS message routing and screening.

Singing Return Loss

The term "Singing Return Loss" denotes the frequency weighted measure of return loss at the edges of the voiceband (200 to 500 Hz and 2500 to 3200 Hz), where singing (instability) problems are most likely to occur.

Special Order

The term "Special Order" denotes an order for a Billing and Collection Service or an order for a Directory Assistance Service.

Subtending End Office of an Access Tandem

The term "Subtending End Office of an Access Tandem" denotes an end office that has final trunk group routing through that tandem.

Synchronous Test Line

The term "Synchronous Test Line" denotes an arrangement in an end office which performs marginal operational tests of supervisory and ring-tripping functions.

Terminating Direction

The term "Terminating Direction" denotes the use of Access Service for the completion of calls from a customer premises to an end user premises.

Toll Free Code (TFC)

The term "Toll Free Code" denotes a three-digit Numbering Plan Area (NPA) or Area Code that is specifically assigned by the Telecommunications industry for use by Telecommunications Service Providers in the provision of telephone numbers that, unlike traditional telephone numbers and calls, when dialed are toll free to the originating caller. The specific codes assigned and used, or reserved for use, for this purpose are 800, 822, 833, 844, 855, 866, 877, and 888.

Toll Free Code (TFC) Service Management System

The term "Toll Free Code Service Management System" (TFC SMS) denotes the main operations support system used to create and update TFC service records in the national TFC data base

Toll Free Code (TFC) Service Provider

The term "Toll Free Code Service Provider" denotes a telecommunications company, including local exchange carriers and inter-exchange carriers, or a reseller of exchange or interexchange services that offers TFC service to end users.

ISSUED:
March 30, 2007

Mark D. Harper
Director - State Regulatory
5454 W. 110th Street
Overland Park, Kansas 66211

EFFECTIVE:
April 30, 2007

CANCELED
July 1, 2012
Missouri Public
Service Commission
TT-2012-0317, YI-2012-0635

Filed
Missouri Public
Service Commission

UNITED TELEPHONE COMPANY
OF MISSOURI

Second Revised Page 90
Cancels First Revised Page 90

RECEIVED

ACCESS SERVICE

2. General Regulations (Cont'd)

MAR 27 1996

2.6 Definitions (Cont'd)

MISSOURI
Public Service Commission

Signal Transfer Point (STP)

The term "Signal Transfer Point" denotes a packet switch which provides CCS network access and performs CCS message routing and screening.

Singing Return Loss

The term "Singing Return Loss" denotes the frequency weighted measure of return loss at the edges of the voiceband (200 to 500 Hz and 2500 to 3200 Hz), where singing (instability) problems are most likely to occur.

Special Order

The term "Special Order" denotes an order for a Billing and Collection Service or an order for a Directory Assistance Service.

Subtending End Office of an Access Tandem

The term "Subtending End Office of an Access Tandem" denotes an end office that has final trunk group routing through that tandem.

Synchronous Test Line

The term "Synchronous Test Line" denotes an arrangement in an end office which performs marginal operational tests of supervisory and ring-tripping functions.

Terminating Direction

The term "Terminating Direction" denotes the use of Access Service for the completion of calls from a customer premises to an end user premises.

Toll Free Code (TFC)

The term "Toll Free Code" denotes a three-digit Numbering Plan Area (NPA) or Area Code that is specifically assigned by the Telecommunications industry for use by Telecommunications Service Providers in the provision of telephone numbers that, unlike traditional telephone numbers and calls, when dialed are toll free to the originating caller. The specific codes assigned and used, or reserved for use, for this purpose are 800, 822, 833, 844, 855, 866, 877, and 888.

(N)

(N)

Toll Free Code (TFC) Service Management System

The term "Toll Free Code Service Management System" (TFC SMS) denotes the main operations support system used to create and update TFC service records in the national TFC data base.

(M)

(T)

(T)

(T)

Toll Free Code (TFC) Service Provider

The term "Toll Free Code Service Provider" denotes a telecommunications company, including local exchange carriers and interexchange carriers, or a reseller of exchange or interexchange services that offers TFC service to end users.

(T)

(T)

(M)

(T)

ISSUED:
March 27, 1996

BY: John L. Roe
Vice President - Carrier and Regulatory Services
5454 West 110th Street
Overland Park, Kansas 66211

EFFECTIVE:
April 29, 1996

Cancelled
April 30, 2007
Missouri Public
Service Commission

ACCESS SERVICE

RECEIVED

MAR 31 1993

MO. PUBLIC SERVICE COMMISSION

2. General Regulations (Cont'd)

2.6 Definitions (Cont'd)

Signal Transfer Point (STP)

The term "Signal Transfer Point" denotes a packet switch which provides CCS network access and performs CCS message routing and screening.

Singing Return Loss

The term "Singing Return Loss" denotes the frequency weighted measure of return loss at the edges of the voiceband (200 to 500 Hz and 2500 to 3200 Hz), where singing (instability) problems are most likely to occur.

Special Order

The term "Special Order" denotes an order for a Billing and Collection Service or an order for a Directory Assistance Service.

Subtending End Office of an Access Tandem

The term "Subtending End Office of an Access Tandem" denotes an end office that has final trunk group routing through that tandem.

Synchronous Test Line

The term "Synchronous Test Line" denotes an arrangement in an end office which performs marginal operational tests of supervisory and ring-tripping functions.

Terminating Direction

The term "Terminating Direction" denotes the use of Access Service for the completion of calls from a customer premises to an end user premises.

Transmission Measuring (105 Type) Test Line/Responder

The term "Transmission Measuring (105 Type) Test Line/Responder" denotes an arrangement in an end office which provides far-end access to a responder and permits two-way loss and noise measurements to be made on trunks from a near end office.

CANCELLED

APR 29 1995
BY 2nd P.S. #90
Public Service Commission
MISSOURI

RECEIVED

MAY 01 1993

MO. PUBLIC SERVICE COMMISSION

ISSUED:
March 31, 1993

BY: John L. Roe
Vice President - Administration
5454 West 110th Street
Overland Park, Kansas 66211

EFFECTIVE:
May 1, 1993

ACCESS SERVICE

RECEIVED

SEP 17 1992

MISSOURI
Public Service Commission

2. General Regulations (Cont'd)

2.6 Definitions (Cont'd)

Singing Return Loss

The term "Singing Return Loss" denotes the frequency weighted measure of return loss at the edges of the voiceband (200 to 500 Hz and 2500 to 3200 Hz), where singing (instability) problems are most likely to occur.

Special Order

The term "Special Order" denotes an order for a Billing and Collection Service or an order for a Directory Assistance Service.

Subtending End Office of an Access Tandem

The term "Subtending End Office of an Access Tandem" denotes an end office that has final trunk group routing through that tandem.

Synchronous Test Line

The term "Synchronous Test Line" denotes an arrangement in an end office which performs marginal operational tests of supervisory and ring-tripping functions.

Terminating Direction

The term "Terminating Direction" denotes the use of Access Service for the completion of calls from a customer premises to an end user premises.

Transmission Measuring (105 Type) Test Line/Responder

The term "Transmission Measuring (105 Type) Test Line/Responder" denotes an arrangement in an end office which provides far-end access to a responder and permits two-way loss and noise measurements to be made on trunks from a near end office.

CANCELLED

MAY 1 1993
BY let R.S. #90
Public Service Commission
MISSOURI

FILED

NOV 7 1992

MO. PUBLIC SERVICE COM.

ISSUED:
September 17, 1992

BY: John L. Roe
Vice President - Administration
5454 West 110th Street
Overland Park, Kansas 66211

EFFECTIVE:
~~September 17, 1992~~

NOV 7 1992

ACCESS SERVICE

2. General Regulations (Cont'd)

2.6 Definitions (Cont'd)

Toll Free Code (TFC)

The term "Toll Free Code" denotes a three-digit Numbering Plan Area (NPA) or Area Code that is specifically assigned by the Telecommunications industry for use by Telecommunications Service Providers in the provision of telephone numbers that, unlike traditional telephone numbers and calls, when dialed are toll free to the originating caller. The specific codes assigned and used, or reserved for use, for this purpose are 800, 822, 833, 844, 855, 866, 877, and 888.

Toll Free Code (TFC) Service Management System

The term "Toll Free Code Service Management System" (TFC SMS) denotes the main operations support system used to create and update TFC service records in the national TFC data base

Toll Free Code (TFC) Service Provider

The term "Toll Free Code Service Provider" denotes a telecommunications company, including local exchange carriers and inter-exchange carriers, or a reseller of exchange or interexchange services that offers TFC service to end users.

(M)

(M)

CANCELLED - Missouri Public Service Commission - 07/14/2023 - IN-2023-0447 - YI-2024-0001

(M) This material previously appeared on Page 90.

ISSUED:
May 1, 2012

Gary L. Kepley
Director - Regulatory Operations
5454 W. 110th Street
Overland Park, Kansas 66211

FILED EFFECTIVE:
Missouri Public July 3, 2012
Service Commission
TT-2012-0317, YI-2012-0635

ACCESS SERVICE

2. General Regulations (Cont'd)

2.6 Definitions (Cont'd)

Toll VoIP-PSTN Traffic

The term "Toll VoIP-PSTN Traffic" denotes a customer's interexchange voice traffic exchanged with the Telephone Company in Time Division Multiplexing format over PSTN facilities, which originates and/or terminates in Internet Protocol (IP) format. "Toll VoIP-PSTN Traffic" originates and/or terminates in IP format when it originates from and/or terminates to an end user customer of a service that requires IP-compatible customer premises equipment.

Transmission Measuring (105 Type) Test Line/Responder

The term "Transmission Measuring (105 Type) Test Line/Responder" denotes an arrangement in an end office which provides far-end access to a responder and permits two-way loss and noise measurements to be made on trunks from a near end office.

Transmission Path

The term "Transmission Path" denotes an electrical path capable of transmitting signals within the range of the service offering, e.g., a voice grade transmission path is capable of transmitting voice frequencies within the approximate range of 300 to 3000 Hz. A transmission path is comprised of physical or derived channels consisting of any form or configuration of facilities typically used in the telecommunications industry.

Trunk

The term "Trunk" denotes a communications path connecting two switching systems in a network, used in the establishment of an end-to-end connection.

Trunk Group

The term "Trunk Group" denotes a set of trunks which are traffic engineered as a unit for the establishment of connections between switching systems in which all of the communications paths are interchangeable.

Trunk Side Connection

The term "Trunk Side Connection" denotes the connection of a transmission path to the trunk side of a local exchange switching system.

Two-Wire to Four-Wire Conversion

The term "Two-Wire to Four-Wire Conversion" denotes an arrangement which converts a four-wire transmission path to a two-wire transmission path to allow a four-wire facility to terminate in a two-wire entity (i.e., a central office switch).

(N)
—
(N)

ISSUED:
December 19, 2011

Gary Kepley
Director - Regulatory Operations
5454 W. 110th Street
Overland Park, Kansas 66211

EFFECTIVE:
January 18, 2011

FILED
Missouri Public
Service Commission
JI-2012-0279

CANCELLED - Missouri Public Service Commission - 07/14/2023 - IN-2023-0447 - YI-2024-0001

ACCESS SERVICE

2. General Regulations (Cont'd)

2.6 Definitions (Cont'd)

Transmission Measuring (105 Type) Test Line/Responder

The term "Transmission Measuring (105 Type) Test Line/Responder" denotes an arrangement in an end office which provides far-end access to a responder and permits two-way loss and noise measurements to be made on trunks from a near end office.

Transmission Path

The term "Transmission Path" denotes an electrical path capable of transmitting signals within the range of the service offering, e.g., a voice grade transmission path is capable of transmitting voice frequencies within the approximate range of 300 to 3000 Hz. A transmission path is comprised of physical or derived channels consisting of any form or configuration of facilities typically used in the telecommunications industry.

Trunk

The term "Trunk" denotes a communications path connecting two switching systems in a network, used in the establishment of an end-to-end connection.

Trunk Group

The term "Trunk Group" denotes a set of trunks which are traffic engineered as a unit for the establishment of connections between switching systems in which all of the communications paths are interchangeable.

Trunk Side Connection

The term "Trunk Side Connection" denotes the connection of a transmission path to the trunk side of a local exchange switching system.

Two-Wire to Four-Wire Conversion

The term "Two-Wire to Four-Wire Conversion" denotes an arrangement which converts a four-wire transmission path to a two-wire transmission path to allow a four-wire facility to terminate in a two-wire entity (i.e., a central office switch).

ISSUED:
March 30, 2007

Mark D. Harper
Director - State Regulatory
5454 W. 110th Street
Overland Park, Kansas 66211

EFFECTIVE:
April 30, 2007

CANCELED
January 18, 2012
Missouri Public
Service Commission
JI-2012-0279

UNITED TELEPHONE COMPANY
OF MISSOURI

First Revised Page 91
Cancels Original Page 91

RECEIVED

ACCESS SERVICE

MAR 27 1996

2. General Regulations (Cont'd)

2.6 Definitions (Cont'd)

MISSOURI
Public Service Commission

Transmission Measuring (105 Type) Test Line/Responder

The term "Transmission Measuring (105 Type) Test Line/Responder" denotes an arrangement in an end office which provides far-end access to a responder and permits two-way loss and noise measurements to be made on trunks from a near end office.

(M)
|
(M)

Transmission Path

The term "Transmission Path" denotes an electrical path capable of transmitting signals within the range of the service offering, e.g., a voice grade transmission path is capable of transmitting voice frequencies within the approximate range of 300 to 3000 Hz. A transmission path is comprised of physical or derived channels consisting of any form or configuration of facilities typically used in the telecommunications industry.

Trunk

The term "Trunk" denotes a communications path connecting two switching systems in a network, used in the establishment of an end-to-end connection.

Trunk Group

The term "Trunk Group" denotes a set of trunks which are traffic engineered as a unit for the establishment of connections between switching systems in which all of the communications paths are interchangeable.

Trunk Side Connection

The term "Trunk Side Connection" denotes the connection of a transmission path to the trunk side of a local exchange switching system.

Two-Wire to Four-Wire Conversion

The term "Two-Wire to Four-Wire Conversion" denotes an arrangement which converts a four-wire transmission path to a two-wire transmission path to allow a four-wire facility to terminate in a two-wire entity (i.e., a central office switch).

MAR 27 1996

ISSUED:
March 27, 1996

BY: John L. Roe
Vice President - Carrier and Regulatory Services
5454 West 110th Street
Overland Park, Kansas 66211

EFFECTIVE:
April 29, 1996

Cancelled
April 30, 2007
Missouri Public
Service Commission

ACCESS SERVICE

RECEIVED

2. General Regulations (Cont'd)

SEP 17 1992

2.6 Definitions (Cont'd)

MISSOURI
Public Service Commission

Transmission Path

The term "Transmission Path" denotes an electrical path capable of transmitting signals within the range of the service offering, e.g., a voice grade transmission path is capable of transmitting voice frequencies within the approximate range of 300 to 3000 Hz. A transmission path is comprised of physical or derived channels consisting of any form or configuration of facilities typically used in the telecommunications industry.

Trunk

The term "Trunk" denotes a communications path connecting two switching systems in a network, used in the establishment of an end-to-end connection.

Trunk Group

The term "Trunk Group" denotes a set of trunks which are traffic engineered as a unit for the establishment of connections between switching systems in which all of the communications paths are interchangeable.

Trunk Side Connection

The term "Trunk Side Connection" denotes the connection of a transmission path to the trunk side of a local exchange switching system.

Two-Wire to Four-Wire Conversion

The term "Two-Wire to Four-Wire Conversion" denotes an arrangement which converts a four-wire transmission path to a two-wire transmission path to allow a four-wire facility to terminate in a two-wire entity (i.e., a central office switch).

CANCELLED

APR 29 1996
BY Let R.S. #91
Public Service Commission
MISSOURI

FILED

NOV 7 1992

MO. PUBLIC SERVICE COMMISSION

ISSUED:
September 17, 1992

BY: John L. Roe
Vice President - Administration
5454 West 110th Street
Overland Park, Kansas 66211

EFFECTIVE:
~~October 17, 1992~~
NOV 7 1992

ACCESS SERVICE

2. General Regulations (Cont'd)

2.6 Definitions (Cont'd)

Uniform Service Order Code

The term "Uniform Service Order Code" denotes a three or five character alphabetic, numeric, or a alphanumeric code that identifies a specific item of service or equipment. Uniform Service Order Codes are used in the Telephone Company billing system to generate recurring rates and nonrecurring charges.

V and H Coordinates Method

The term "V and H Coordinates Method" denotes a method of computing airline miles between two points by utilizing an established formula which is based on the vertical (V) and horizontal (H) coordinates of the two points.

WATS Serving Office

The term "WATS Serving Office" denotes a telephone company designated serving wire center where switching, screening and/or recording functions are performed in connection with the closed-end of WATS or WATS-type services.

Wire Center

The term "Wire Center" denotes a building in which one or more central offices, used for the provision of Telephone Exchange Services, are located.

ISSUED:
March 30, 2007

Mark D. Harper
Director - State Regulatory
5454 W. 110th Street
Overland Park, Kansas 66211

EFFECTIVE:
April 30, 2007

CANCELLED - Missouri Public Service Commission - 07/14/2023 - IN-2023-0447 - YI-2024-0001

SPRINT MISSOURI, INC.
d/b/a SPRINT

First Revised Page 92
Cancels Original Page 92

ACCESS SERVICE

10/11/99

2. General Regulations (Cont'd)

SPRINT 10/11/99

2.6 Definitions (Cont'd)

Uniform Service Order Code

The term "Uniform Service Order Code" denotes a three or five character alphabetic, numeric, or a alphanumeric code that identifies a specific item of service or equipment. Uniform Service Order Codes are used in the Telephone Company billing system to generate recurring rates and nonrecurring charges.

(D)
|
(D)

V and H Coordinates Method

The term "V and H Coordinates Method" denotes a method of computing airline miles between two points by utilizing an established formula which is based on the vertical (V) and horizontal (H) coordinates of the two points.

WATS Serving Office

The term "WATS Serving Office" denotes a telephone company designated serving wire center where switching, screening and/or recording functions are performed in connection with the closed-end of WATS or WATS-type services.

Wire Center

The term "Wire Center" denotes a building in which one or more central offices, used for the provision of Telephone Exchange Services, are located.

(D)

ISSUED:
September 10, 1999

Richard D. Lawson
State Executive, External Affairs

October 11, 1999
OCT 15 1999

Cancelled
April 30, 2007
Missouri Public
Service Commission

UNITED TELEPHONE COMPANY
OF MISSOURI

Original Page 92

ACCESS SERVICE

RECEIVED

SEP 17 1992

2. General Regulations (Cont'd)

2.6 Definitions (Cont'd)

MISSOURI
Public Service Commission

Uniform Service Order Code

The term "Uniform Service Order Code" denotes a three or five character alphabetic, numeric, or a alphanumeric code that identifies a specific item of service or equipment. Uniform Service Order Codes are used in the Telephone Company billing system to generate recurring rates and nonrecurring charges.

United DigiLinkSM

The term United DigiLinkSM denotes a digital transmission service designed to transmit signals, end to end, at speeds of 2.4, 4.8, 9.6, 19.2 or 56 kbps over digital facilities routed through the Telephone Company central offices.

United TransLinkSM

The term United TransLinkSM denotes a digital transmission service designed to transmit signals, end to end, at a speed of 1.544 Mbps, over digital facilities routed through the Telephone Company central offices.

V and H Coordinates Method

The term "V and H Coordinates Method" denotes a method of computing airline miles between two points by utilizing an established formula which is based on the vertical (V) and horizontal (H) coordinates of the two points.

WATS Serving Office

The term "WATS Serving Office" denotes a telephone company designated serving wire center where switching, screening and/or recording functions are performed in connection with the closed-end of WATS or WATS-type services.

Wire Center

The term "Wire Center" denotes a building in which one or more central offices, used for the provision of Telephone Exchange Services, are located.

SM Registered service mark of United Telecommunications, Inc. **FILED**

NOV 7 1992

MO. PUBLIC SERVICE COMMISSION

EFFECTIVE:

~~October 17, 1992~~

NOV 7 1992

ISSUED:
September 17, 1992

BY: John L. Roe
Vice President - Administration
5454 West 110th Street
Overland Park, Kansas 66211

CANCELLED
OCT 15 1999
By *1st RS # 92*
Public Service Commission
MISSOURI

ACCESS SERVICE

3. Carrier Common Line Access Service

The Telephone Company will provide Carrier Common Line Access Service to customers.

3.1 General Description

Carrier Common Line Access provides for the use of Telephone Company common lines by customers for access to such end users to furnish Intrastate Communications.

Carrier Common Line Access is provided where the customer obtains Telephone Company Switched Access Service under this tariff.

Switched Access Service is provided to ICs under this tariff which furnish intrastate MTS/WATS and MTS/WATS type service, and in an end office converted to equal access.

In addition, a Special Access Surcharge will apply to intrastate special access service provided by the Telephone Company to a customer, in accordance with regulations as set forth in 7.4.2 following.

ISSUED:
March 30, 2007

Mark D. Harper
Director - State Regulatory
5454 W. 110th Street
Overland Park, Kansas 66211

EFFECTIVE:
April 30, 2007

CANCELLED - Missouri Public Service Commission - 07/14/2023 - IN-2023-0447 - YI-2024-0001

ACCESS SERVICE

3. Carrier Common Line Access Service

NOV 3 1993

The Telephone Company will provide Carrier Common Line Access Service to customers.

MO. PUBLIC SERVICE COMM.

3.1 General Description

Carrier Common Line Access provides for the use of Telephone Company commonlines by customers for access to such end users to furnish Intrastate Communications.

Carrier Common Line Access is provided where the customer obtains Telephone Company Switched Access Service under this tariff.

Switched Access Service is provided to ICs under this tariff which furnish intrastate MTS/WATS and MTS/WATS type service, and in an end office converted to equal access.

(T)

(T)

(D)

In addition, a Special Access Surcharge will apply to intrastate special access service provided by the Telephone Company to a customer, in accordance with regulations as set forth in 7.4.2 following.

FILED

NOV 7 1993
93 - 181

MO. PUBLIC SERVICE COMM.

ISSUED:
November 3, 1993

BY: John L. Roe
Vice President - Administration
5454 West 110th Street
Overland Park, Kansas 66211

EFFECTIVE:
November 7, 1993

Cancelled

April 30, 2007
Missouri Public
Service Commission

UNITED TELEPHONE COMPANY
OF MISSOURI

Original Page 93

RECEIVED

SEP 17 1992

ACCESS SERVICE

MISSOURI
Public Service Commission

3. Carrier Common Line Access Service

The Telephone Company will provide Carrier Common Line Access Service to customers.

3.1 General Description

Carrier Common Line Access provides for the use of Telephone Company common lines by customers for access to such end users to furnish Intrastate Communications.

Carrier Common Line Access is provided where the customer obtains Telephone Company Switched Access Service under this tariff.

Premium Access is (1) Switched Access Service provided to ICs under this tariff which furnish intrastate MTS/WATS and MTS/WATS type service, and (2) Switched Access Service in an end office converted to equal access.

The Telephone Company does not offer non-premium switched access service.

In addition, a Special Access Surcharge will apply to intrastate special access service provided by the Telephone Company to a customer, in accordance with regulations as set forth in 7.4.2 following.

CANCELLED

NOV 7 1992
BY *1st R.S. #93*
Public Service Commission
MISSOURI

FILED

NOV 7 1992

MO. PUBLIC SERVICE COMMISSION

ISSUED:
September 17, 1992

BY: John L. Roe
Vice President Administration
5454 West 110th Street
Overland Park, Kansas, 66211

EFFECTIVE:
~~September 17, 1992~~
NOV 7 1992

ACCESS SERVICE

3. Carrier Common Line Access Service (Cont'd)

3.2 Limitations

- (A) A telephone number is not provided with Carrier Common Line Access.
- (B) Detail billing is not provided for Carrier Common Line Access.
- (C) Directory listings are not included in the rates and charges for Carrier Common Line Access.
- (D) Intercept arrangements are not included in the rates and charges for Carrier Common Line Access.
- (E) All line side connections provided in the same access group will be limited to the same features and operating characteristics.
- (F) All trunk side connections provided in the same access group will be limited to the same features and operating characteristics.
- (G) Where Special Access Services are connected with Special Access Services at Telephone Company Designated WATS serving offices for the provisioning of WATS or WATS-type Services, Switched Access Service minutes which are carried on that service (i.e., originating minutes for outward WATS and WATS-type services and terminating minutes for inward WATS and WATS-type services) shall not be assessed Carrier Common Line Access per minute charges.

ISSUED:
March 30, 2007

Mark D. Harper
Director - State Regulatory
5454 W. 110th Street
Overland Park, Kansas 66211

EFFECTIVE:
April 30, 2007

RECEIVED

SEP 17 1992

ACCESS SERVICE

3. Carrier Common Line Access Service (Cont'd)

3.2 Limitations

- (A) A telephone number is not provided with Carrier Common Line Access.
- (B) Detail billing is not provided for Carrier Common Line Access.
- (C) Directory listings are not included in the rates and charges for Carrier Common Line Access.
- (D) Intercept arrangements are not included in the rates and charges for Carrier Common Line Access.
- (E) All line side connections provided in the same access group will be limited to the same features and operating characteristics.
- (F) All trunk side connections provided in the same access group will be limited to the same features and operating characteristics.
- (G) Where Special Access Services are connected with Special Access Services at Telephone Company Designated WATS serving offices for the provisioning of WATS or WATS-type Services, Switched Access Service minutes which are carried on that service (i.e., originating minutes for outward WATS and WATS-type services and terminating minutes for inward WATS and WATS-type services) shall not be assessed Carrier Common Line Access per minute charges.

ISSUED:
September 17, 1992

BY: John L. Roe
Vice President Administration
5454 West 110th Street
Overland Park, Kansas, 66211

1992
2 1992
EFFECTIVE:
~~October 13, 1992~~
NOV 7 1992

ACCESS SERVICE

3. Carrier Common Line Access Service (Cont'd)

3.3 Undertaking of the Telephone Company

- (A) Where the customer is provided Switched Access Service under other sections of this tariff, the Telephone Company will provide the use of Telephone Company common lines by a customer for access to end users at rates and charges as set forth in 3.8 following.
- (B) Where the customer is reselling intrastate MTS/WATS, MTS-type and/or WATS-type service(s), the customer may, at the option of the customer, employ ordinary local business exchange service at generally applicable local business exchange rates under the Telephone Company General and/or Local Exchange Tariffs. Switched Access or Carrier Common Line Access charges under this Tariff will not apply for such access except as set forth in Section 6.7, and 3.7. following, provided the underlying carrier that provides the MTS/WATS and/or MTS/WATS-type service(s) which are resold compensates the Telephone company in accordance with the provisions in this tariff. Such compensation shall include charges for which are resold. If the customer wishes to obtain special arrangements such as trunk side service connections for such resale, the customer may, at the option of the customer, obtain Switched Access Service under this Tariff as set forth in Section 6, following. Carrier Common Line Access charges will apply for such access as set forth in 3.7. following.
- (C) When access to the local exchange is required to provide a MTS/WATS-type service using a resold Private Line Service, Switched Access Service Rates and Regulations, as set forth in 6. following will apply. Carrier Common Line Access rates and charges as set forth in 3.8 following apply in accordance with the regulations as set forth 3.7 following.
- (D) The Switched Access Service provided by the Telephone Company includes the Switched Access Service provided for both interstate and intrastate communications and the Carrier Common Line Access rates and charges as set forth in 3.8 following apply in accordance with the rate regulations as set forth in 3.7 following.

ISSUED:
March 30, 2007

Mark D. Harper
Director - State Regulatory
5454 W. 110th Street
Overland Park, Kansas 66211

EFFECTIVE:
April 30, 2007

CANCELLED - Missouri Public Service Commission - 07/14/2023 - IN-2023-0447 - YI-2024-0001

UNITED TELEPHONE COMPANY
OF MISSOURI

Original Page 95

RECEIVED

SEP 17 1992

ACCESS SERVICE

3. Carrier Common Line Access Service (Cont'd)

3.3 Undertaking of the Telephone Company

- (A) Where the customer is provided Switched Access Service under other sections of this tariff, the Telephone Company will provide the use of Telephone Company common lines by a customer for access to end users at rates and charges as set forth in 3.8 following.
- (B) Where the customer is reselling intrastate MTS/WATS, MTS-type and/or WATS-type service(s), the customer may, at the option of the customer, employ ordinary local business exchange service at generally applicable local business exchange rates under the Telephone Company General and/or Local Exchange Tariffs. Switched Access or Carrier Common Line Access charges under this Tariff will not apply for such access except as set forth in Section 6.7, and 3.7. following, provided the underlying carrier that provides the MTS/WATS and/or MTS/WATS-type service(s) which are resold compensates the Telephone company in accordance with the provisions in this tariff. Such compensation shall include charges for which are resold. If the customer wishes to obtain special arrangements such as trunk side service connections for such resale, the customer may, at the option of the customer, obtain Switched Access Service under this Tariff as set forth in Section 6, following. Carrier Common Line Access charges will apply for such access as set forth in 3.7. following.
- (C) When access to the local exchange is required to provide a MTS/WATS-type service using a resold Private Line Service, Switched Access Service Rates and Regulations, as set forth in 6. following will apply. Carrier Common Line Access rates and charges as set forth in 3.8 following apply in accordance with the regulations as set forth 3.7 following.
- (D) The Switched Access Service provided by the Telephone Company includes the Switched Access Service provided for both interstate and intrastate communications and the Carrier Common Line Access rates and charges as set forth in 3.8 following apply in accordance with the rate regulations as set forth in 3.7 following.

MISSOURI PUBLIC SERVICE COMMISSION

NOV 7 1992

ISSUED:
September 17, 1992

BY: John L. Roe
Vice President Administration
5454 West 110th Street
Overland Park, Kansas, 66211

EFFECTIVE:
~~October 1, 1992~~
NOV 7 1992

Cancelled
April 30, 2007
Missouri Public
Service Commission

ACCESS SERVICE

3. Carrier Common Line Access Service (Cont'd)

(D)

3.4 Obligations of the Customer

- (A) The Switched Access Service associated with Carrier Common Line Access shall be ordered by the customer under other sections of this tariff.
- (B) The customer facilities at the premises of ordering customer shall provide the necessary on-hook and off-hook supervision.
- (C) Unless the customer reports (1) intrastate use as set forth in (D) following or (2) Feature Group A, B or D Switched Access Service as set forth in (F) following, all Switched Access Service provided to the customer will be subject to Carrier Common Line Access charges.
- (D) When the customer reports interstate and intrastate use of Switched Access Service, the associated Carrier Common Line Access used by the customer for intrastate will be determined as set forth in 3.7 following.
- (E) Where Feature Group C end office switching is provided without Telephone Company recording and the IC records minutes of use used to determine Carrier Common Line Access charges (i.e., Feature Group C operator and TSPS calls such as pay telephone sent-paid, operator-DDD, operator-person, collect, credit-card, third number and/or other like calls), the IC shall furnish such minutes of use detail to the Telephone Company in a timely manner. If the IC does not furnish the data to the Telephone Company, the IC shall identify all Switched Access Services which could carry such calls in order for the Telephone Company to accumulate the minutes of use through the use of special Telephone Company measuring and recording equipment.

ISSUED:
March 30, 2007

Mark D. Harper
Director - State Regulatory
5454 W. 110th Street
Overland Park, Kansas 66211

EFFECTIVE:
April 30, 2007

CANCELLED - Missouri Public Service Commission - 07/14/2023 - IN-2023-0447 - YI-2024-0001

UNITED TELEPHONE COMPANY
OF MISSOURI d/b/a SPRINT

First Revised Page 96
Cancels Original Page 96

ACCESS SERVICE

RECEIVED

3. Carrier Common Line Access Service (Cont'd)

APR 15 1997

3.3 Undertaking of the Telephone Company (Cont'd)

MISSOURI
Public Service Commission (D)

(D)

3.4 Obligations of the Customer

- (A) The Switched Access Service associated with Carrier Common Line Access shall be ordered by the customer under other sections of this tariff.
- (B) The customer facilities at the premises of ordering customer shall provide the necessary on-hook and off-hook supervision.
- (C) Unless the customer reports (1) intrastate use as set forth in (D) following or (2) Feature Group A, B or D Switched Access Service as set forth in (F) following, all Switched Access Service provided to the customer will be subject to Carrier Common Line Access charges.
- (D) When the customer reports interstate and intrastate use of Switched Access Service, the associated Carrier Common Line Access used by the customer for intrastate will be determined as set forth in 3.7 following.
- (E) Where Feature Group C end office switching is provided without Telephone Company recording and the IC records minutes of use used to determine Carrier Common Line Access charges (i.e., Feature Group C operator and TSPS calls such as pay telephone sent-paid, operator-DDD, operator-person, collect, credit-card, third number and/or other like calls), the IC shall furnish such minutes of use detail to the Telephone Company in a timely manner. If the IC does not furnish the data to the Telephone Company, the IC shall identify all Switched Access Services which could carry such calls in order for the Telephone Company to accumulate the minutes of use through the use of special Telephone Company measuring and recording equipment.

APR 15 1997

ISSUED:
January 15, 1997

BY: John L. Roe
VP = Carrier and Regulatory Services
5454 West 110th Street
Overland Park, Kansas 66211

MISSOURI PUBLIC SERVICE COMMISSION
EFFECTIVE:

APR 15 1997

UNITED TELEPHONE COMPANY
OF MISSOURI

Original Page 96

RECEIVED

ACCESS SERVICE

SEP 17 1992

3. Carrier Common Line Access Service (Cont'd)

MISSOURI

3.3 Undertaking of the Telephone Company (Cont'd) Public Service Commission

(E) When the IC is provided Operator Trunk-Coin or Combined Coin and Non-Coin or Operator Trunk-full Feature Optional Features for sent-paid pay telephone access as set forth following in 6., the Telephone Company will collect sent-paid monies from pay telephone stations and will remit monies to the IC as set forth in 3.6 following. The Telephone Company will provide message call detail format and bill periods used to determine the monies upon request from the IC.

3.4 Obligations of the Customer

- (A) The Switched Access Service associated with Carrier Common Line Access shall be ordered by the customer under other sections of this tariff.
- (B) The customer facilities at the premises of ordering customer shall provide the necessary on-hook and off-hook supervision.
- (C) Unless the customer reports (1) intrastate use as set forth in (D) following or (2) Feature Group A, B or D Switched Access Service as set forth in (F) following, all Switched Access Service provided to the customer will be subject to Carrier Common Line Access charges.
- (D) When the customer reports interstate and intrastate use of Switched Access Service, the associated Carrier Common Line Access used by the customer for intrastate will be determined as set forth in 3.7 following.
- (E) Where Feature Group C end office switching is provided without Telephone Company recording and the IC records minutes of use used to determine Carrier Common Line Access charges (i.e., Feature Group C operator and TSPS calls such as pay telephone sent-paid, operator-DDD, operator-person, collect, credit-card, third number and/or other like calls), the IC shall furnish such minutes of use detail to the Telephone Company in a timely manner. If the IC does not furnish the data to the Telephone Company, the IC shall identify all Switched Access Services which could carry such calls in order for the Telephone Company to accumulate the minutes of use through the use of special telephone Company measuring and recording equipment.

APR 15 1997
BY J.L.R.S #96
Public Service Commission
MISSOURI

FILED

NOV 7 1992

MO. PUBLIC SERVICE COMMISSION
EFFECTIVE:

~~September 17, 1992~~

NOV 7 1992

ISSUED:
September 17, 1992

BY: John L. Roe
Vice President Administration
5454 West 110th Street
Overland Park, Kansas, 66211

ACCESS SERVICE

3. Carrier Common Line Access Service (Cont'd)

3.4 Obligations of the Customer (Cont'd)

- (F) When the customer is reselling MTS/WATS and/or MTS/WATS-type service as set forth in 3.3(B) preceding, the customer will be charged the Carrier Common Line Access charges in accordance with the regulations as set forth in 3.7 following if the customer or the provider of the MTS/WATS service furnishes documentation of the MTS/WATS and/or the customer furnishes documentation of the MTS/WATS-type usage. Such documentation supplied by the customer shall be supplied each month and shall identify the involved resold MTS and/or MTS type services.
- (G) When the customer orders Switched Access Service as set forth in (F) preceding, the Telephone Company may request when resold MTS/WATS is involved, a certified copy of the customer's MTS/WATS usage billing from either the customer or the provider of the MTS/WATS Service and/or when resold MTS/WATS-type service is involved, a certified copy of customer's MTS/WATS-type usage billing from either the customer or the provider of the MTS/WATS-type service. The requests for this billing will relate back no more than 12 months prior to the current billing period.

CANCELLED - Missouri Public Service Commission - 07/14/2023 - IN-2023-0447 - YI-2024-0001

ISSUED:
March 30, 2007

Mark D. Harper
Director - State Regulatory
5454 W. 110th Street
Overland Park, Kansas 66211

EFFECTIVE:
April 30, 2007

UNITED TELEPHONE COMPANY
OF MISSOURI

Original Page 97

RECEIVED

SEP 17 1992

ACCESS SERVICE

3. Carrier Common Line Access Service (Cont'd)

3.4 Obligations of the Customer (Cont'd)

WTS
... .. sion

- (F) When the customer is reselling MTS/WATS and/or MTS/WATS-type service as set forth in 3.3(B) preceding, the customer will be charged the Carrier Common Line Access charges in accordance with the regulations as set forth in 3.7 following if the customer or the provider of the MTS/WATS service furnishes documentation of the MTS/WATS and/or the customer furnishes documentation of the MTS/WATS-type usage. Such documentation supplied by the customer shall be supplied each month and shall identify the involved resold MTS and/or MTS type services.
- (G) When the customer orders Switched Access Service as set forth in (F) preceding, the Telephone Company may request when resold MTS/WATS is involved, a certified copy of the customer's MTS/WATS usage billing from either the customer or the provider of the MTS/WATS Service and/or when resold MTS/WATS-type service is involved, a certified copy of customer's MTS/WATS-type usage billing from either the customer or the provider of the MTS/WATS-type service. The requests for this billing will relate back no more than 12 months prior to the current billing period.

ISSUED:
September 17, 1992

BY: John L. Roe
Vice President Administration
5454 West 110th Street
Overland Park, Kansas, 66211

EFFECTIVE:
~~September 17, 1992~~
NOV 7 1992

ACCESS SERVICE

3. Carrier Common Line Access Service (Cont'd)

3.5 Payment Arrangements

- (A) The Telephone company will bill the Carrier Common Line Access. the bill day (i.e., the billing date of the bill) in a month for each customer account will be established by the Telephone Company. Payment is due from the customer 31 days after the bill day date (payment date) or by the next bill date (i.e., same date in the following month as the bill date), whichever is the shortest interval, and is payable in immediately available funds. If such payment day is a Saturday, Sunday or Holiday (i.e., New Year's Day, Independence Day, Labor Day, Thanksgiving Day, Christmas day, the second Tuesday in November, and a day when Washington's Birthday, Memorial Day or Columbus Day is legally observed), payment will be due from the customer as follows:

ISSUED:
March 30, 2007

Mark D. Harper
Director - State Regulatory
5454 W. 110th Street
Overland Park, Kansas 66211

EFFECTIVE:
April 30, 2007

CANCELLED - Missouri Public Service Commission - 07/14/2023 - IN-2023-0447 - YI-2024-0001

UNITED TELEPHONE COMPANY
OF MISSOURI d/b/a SPRINT

First Revised Page 98
Cancels Original Page 98

RECEIVED

ACCESS SERVICE

3. Carrier Common Line Access Service (Cont'd)

JAN 15 1997

MISSOURI (D)
Public Service Commission

(D)

3.5 Payment Arrangements

(A) The Telephone company will bill the Carrier Common Line Access. the bill day (i.e., the billing date of the bill) in a month for each customer account will be established by the Telephone Company. Payment is due from the customer 31 days after the bill day date (payment date) or by the next bill date (i.e., same date in the following month as the bill date), whichever is the shortest interval, and is payable in immediately available funds. If such payment day is a Saturday, Sunday or Holiday (i.e., New Year's Day, Independence Day, Labor Day, Thanksgiving Day, Christmas day, the second Tuesday in November, and a day when Washington's Birthday, Memorial Day or Columbus Day is legally observed), payment will be due from the customer as follows:

FILED

APR 15 1997

MO. PUBLIC SERVICE COMMISSION

ISSUED:
January 15, 1997

BY: John L. Roe
VP - Carrier and Regulatory Services
5454 West 110th Street
Overland Park, Kansas 66211

EFFECTIVE:
~~January 15, 1997~~
APR 15 1997

UNITED TELEPHONE COMPANY
OF MISSOURI

Original Page 98

RECEIVED

SEP 17 1992

ACCESS SERVICE

3. Carrier Common Line Access Service (Cont'd)

3.4 Obligations to the Customer (Cont'd)

MISSOURI
Public Service Commission

(I) Where Operator Trunk-coin or Combined Coin and Non Coin or Operator Trunk-Full Feature Optional Features for sent-paid pay telephone access is provided to the IC and the IC wishes to receive the monies it is due for monies collected by the Telephone Company from coin pay telephone stations, the IC shall furnish to the Telephone Company, at a location specified by the Telephone Company, the IC message call detail for the IC sent-paid (coin) pay telephone calls in accordance with the Telephone Company collection schedule. The IC message call detail furnished shall be in a standard format established by the Telephone Company as set forth in 8.2.1(B)(1)(c) following. If no IC message call detail is received from the IC for each bill period established by the Telephone Company, the Telephone Company will assume there were no IC sent-paid (coin) pay telephone calls for the period. In addition, the IC shall furnish a schedule of its charges for sent-paid (coin) calls to the Telephone at a location and date as specified by the Telephone Company. Any change in the IC's schedule of charges shall be furnished to the Telephone Company one day after the change becomes effective.

3.5 Payment Arrangements

(A) The Telephone company will bill the Carrier Common Line Access. the bill day (i.e., the billing date of the bill) in a month for each customer account will be established by the Telephone Company. Payment is due from the customer 31 days after the bill day date (payment date) or by the next bill date (i.e., same date in the following month as the bill date), whichever is the shortest interval, and is payable in immediately available funds. If such payment day is a Saturday, Sunday or Holiday (i.e., New Year's Day, Independence Day, Labor Day, Thanksgiving Day, Christmas day, the second Tuesday in November, and a day when Washington's Birthday, Memorial Day or Columbus Day is legally observed), payment will be due from the customer as follows:

CANCELLED

APR 15 1997
BY John P.S. [signature]
Public Service Commission
MISSOURI

FILED

NOV 7 1992

NO. 21-135-1103-30001.

ISSUED:
September 17, 1992

BY: John L. Roe
Vice President Administration
5454 West 110th Street
Overland Park, Kansas, 66211

EFFECTIVE:
~~October 17, 1992~~
NOV 7 1992

ACCESS SERVICE

3. Carrier Common Line Access Service (Cont'd)

3.5 Payment Arrangements (Cont'd)

(A) (Cont'd)

If such payment date falls on a Sunday or on a Holiday which is observed on a Monday, the payment date shall be the first non-Holiday day following such Sunday or Holiday. If such payment date falls on a Saturday or on a Holiday which is observed on Tuesday, Wednesday, Thursday or Friday, the payment date shall be the last non-Holiday day preceding such Saturday or Holiday.

(B) Further, if any portion of the Carrier Common Line Access payment is received by the Telephone company after the payment date as set forth in the (A) preceding, or if any portion of the Carrier Common Line Access payment is received by the Telephone company in funds which are not immediately available to the Telephone Company, then a late payment penalty shall be due to the Telephone Company. The late payment penalty shall be the portion of the Carrier Common Line Access payment not received by payment date times a late factor. The late factor shall be the lesser of:

(1) the highest interest rate (in decimal value) which may be levied by the law for commercial transactions, compounded daily for the number of days from the payment date to and including the date that the customer actually makes the payment to the Telephone Company or

(2) 0.000407 per day, compounded daily for the number of days from the payment date to and including the date that the customer actually makes the payment to the Telephone Company. (R)

(C) In the event a billing dispute concerning a month's Carrier Common Line Access Billed to the customer by the Telephone Company is resolved in favor of the Telephone Company, any payments withheld pending settlement of the dispute shall be subject to the late payment penalty set forth in (B) preceding. If the customer disputes the bill on or before the payment date, and pays the undisputed amount on or before the payment date, any late payment charge for the disputed amount will not start until 10 days after the payment date. If the billing dispute is resolved in favor

ISSUED:
February 27, 2017

Gary L. Kepley
Director, Regulatory Operations
600 New Century Parkway
New Century, Kansas 66031

EFFECTIVE:
April 1, 2017

17-02A

FILED
Missouri Public
Service Commission
JI-2017-0168

CANCELLED - Missouri Public Service Commission - 07/14/2023 - IN-2023-0447 - YI-2024-0001

ACCESS SERVICE

3. Carrier Common Line Access Service (Cont'd)

3.5 Payment Arrangements (Cont'd)

(A) (Cont'd)

If such payment date falls on a Sunday or on a Holiday which is observed on a Monday, the payment date shall be the first non-Holiday day following such Sunday or Holiday. If such payment date falls on a Saturday or on a Holiday which is observed on Tuesday, Wednesday, Thursday or Friday, the payment date shall be the last non-Holiday day preceding such Saturday or Holiday.

(B) Further, if any portion of the Carrier Common Line Access payment is received by the Telephone company after the payment date as set forth in the (A) preceding, or if any portion of the Carrier Common Line Access payment is received by the Telephone company in funds which are not immediately available to the Telephone Company, then a late payment penalty shall be due to the Telephone Company. The late payment penalty shall be the portion of the Carrier Common Line Access payment not received by payment date times a late factor. The late factor shall be the lesser of:

- (1) the highest interest rate (in decimal value) which may be levied by the law for commercial transactions, compounded daily for the number of days from the payment date to and including the date that the customer actually makes the payment to the Telephone Company or
- (2) 0.000590 per day, compounded daily for the number of days from the payment date to and including the date that the customer actually makes the payment to the Telephone Company.

(C) In the event a billing dispute concerning a month's Carrier Common Line Access Billed to the customer by the Telephone Company is resolved in favor of the Telephone Company, any payments withheld pending settlement of the dispute shall be subject to the late payment penalty set forth in (B) preceding. If the customer disputes the bill on or before the payment date, and pays the undisputed amount on or before the payment date, any late payment charge for the disputed amount will not start until 10 days after the payment date. If the billing dispute is resolved in favor

ISSUED:
March 30, 2007

Mark D. Harper
Director - State Regulatory
5454 W. 110th Street
Overland Park, Kansas 66211

EFFECTIVE:
April 30, 2007

CANCELLED
April 1, 2017
Missouri Public
Service Commission
JI-2017-0168

Filed
Missouri Public
Service Commission

UNITED TELEPHONE COMPANY
OF MISSOURI

Original Page 99

ACCESS SERVICE

RECEIVED

3. Carrier Common Line Access Service (Cont'd)

SEP 17 1992

3.5 Payment Arrangements (Cont'd)

(A) (Cont'd)

If such payment date falls on a Sunday or on a Holiday which is observed on a Monday, the payment date shall be the first non-Holiday day following such Sunday or Holiday. If such payment date falls on a Saturday or on a Holiday which is observed on Tuesday, Wednesday, Thursday or Friday, the payment date shall be the last non-Holiday day preceding such Saturday or Holiday.

(B) Further, if any portion of the Carrier Common Line Access payment is received by the Telephone company after the payment date as set forth in the (A) preceding, or if any portion of the Carrier Common Line Access payment is received by the Telephone company in funds which are not immediately available to the Telephone Company, then a late payment penalty shall be due to the Telephone Company. The late payment penalty shall be the portion of the Carrier Common Line Access payment not received by payment date times a late factor. The late factor shall be the lesser of:

(1) the highest interest rate (in decimal value) which may be levied by the law for commercial transactions, compounded daily for the number of days from the payment date to and including the date that the customer actually makes the payment to the Telephone Company or

(2) 0.000590 per day, compounded daily for the number of days from the payment date to and including the date that the customer actually makes the payment to the Telephone Company.

(C) In the event a billing dispute concerning a month's Carrier Common Line Access Billed to the customer by the Telephone Company is resolved in favor of the Telephone Company, any payments withheld pending settlement of the dispute shall be subject to the late payment penalty set forth in (B) preceding. If the customer disputes the bill on or before the payment date, and pays the undisputed amount on or before the payment date, any late payment charge for the disputed amount will not start until 10 days after the payment date. If the billing dispute is resolved in favor

ISSUED:
September 17, 1992

BY: John L. Roe
Vice President Administration
5454 West 110th Street
Overland Park, Kansas, 66211

EFFECTIVE:

~~October 1, 1992~~

NOV 7 1992

Cancelled
April 30, 2007
Missouri Public
Service Commission

ACCESS SERVICE

3. Carrier Common Line Access Service (Cont'd)

3.5 Payment Arrangements (Cont'd)

(C) (Cont'd)

of the customer, no late payment penalty will apply to the disputed amount. In addition, if the customer disputes the billed amount and pays the total amount (i.e., the non-disputed amount and the disputed amount) on or before the payment date and the billing dispute is resolved in the favor of the customer, the customer will receive a credit for a disputed amount penalty from the Telephone Company if the billing dispute is not resolved within 10 working days following the payment date or the date the customer furnishes to the Telephone Company documentation to support its claim plus 10 working days, whichever date is the later date. The disputed amount penalty shall be the disputed amount resolved in the customer's favor times a penalty factor.

CANCELLED - Missouri Public Service Commission - 07/14/2023 - IN-2023-0447 - YI-2024-0001

ISSUED:
March 30, 2007

Mark D. Harper
Director - State Regulatory
5454 W. 110th Street
Overland Park, Kansas 66211

EFFECTIVE:
April 30, 2007

UNITED TELEPHONE COMPANY
OF MISSOURI d/b/a SPRINT

First Revised Page 100
Cancels Original Page 100

ACCESS SERVICE

JAN 15 1997

3. Carrier Common Line Access Service (Cont'd)

3.5 Payment Arrangements (Cont'd)

MISSOURI
Public Service Commission

(C) (Cont'd)

of the customer, no late payment penalty will apply to the disputed amount. In addition, if the customer disputes the billed amount and pays the total amount (i.e., the non-disputed amount and the disputed amount) on or before the payment date and the billing dispute is resolved in the favor of the customer, the customer will receive a credit for a disputed amount penalty from the Telephone Company if the billing dispute is not resolved within 10 working days following the payment date or the date the customer furnishes to the Telephone Company documentation to support its claim plus 10 working days, whichever date is the later date. The disputed amount penalty shall be the disputed amount resolved in the customer's favor times a penalty factor.

(D)

FILED

APR 15 1997(D)

MO. PUBLIC SERVICE COMMISSION

ISSUED:
January 15, 1997

BY: John L. Roe
VP - Carrier and Regulatory Services
5454 West 110th Street
Overland Park, Kansas 66211

EFFECTIVE:
~~APR 15 1997~~
APR 15 1997

UNITED TELEPHONE COMPANY
OF MISSOURI

Original Page 100

ACCESS SERVICE

RECEIVED

3. Carrier Common Line Access Service (Cont'd)

SEP 17 1992

3.5 Payment Arrangements (Cont'd)

MISSOURI
Public Service Commission

(C) (Cont'd)

of the customer, no late payment penalty will apply to the disputed amount. In addition, if the customer disputes the billed amount and pays the total amount (i.e., the non-disputed amount and the disputed amount) on or before the payment date and the billing dispute is resolved in the favor of the customer, the customer will receive a credit for a disputed amount penalty from the Telephone Company if the billing dispute is not resolved within 10 working days following the payment date or the date the customer furnishes to the Telephone Company documentation to support its claim plus 10 working days, whichever date is the later date. The disputed amount penalty shall be the disputed amount resolved in the customer's favor times a penalty factor.

3.6 Payment of Coin Sent-Paid Monies

The Telephone company will collect the monies from coin pay telephone stations and will determine and remit amounts due to a IC which is provided Operator Trunk-Coin or Combined Coin and Non-Coin or Operator Trunk-Full Feature Optional Features for sent-paid pay telephone access as set forth in Section 6. as follows:

(A) Bill Period Coin Revenue

The Telephone Company will establish a collection schedule for each coin pay telephone station and will collect the monies from the coin pay stations based on this collection schedule. The monies collected based on this schedule during each bill period established by the Telephone Company will be identified by coin pay telephone station and summed to develop the Bill Period Coin Revenue for each coin record day (i.e., the day a record is prepared and dated to show the amount due the IC).

(B) Total IC Coin Revenue

The intrastate Total IC Coin Revenue will be determined by the Telephone Company based on the customer message call detail received from the customer for each bill period and the customer's schedule of charges for sent-paid coin calls. Such Total Customer Coin Revenue will be developed for each coin record day.

CANCELLED

APR 15 1997
BY *John L. Roe*
Public Service Commission
MISSOURI

FILED

NOV 7 1992

ISSUED:
September 17, 1992

BY: John L. Roe
Vice President Administration
5454 West 110th Street
Overland Park, Kansas, 66211

MO. PUBLIC SERVICE COMMISSION
~~October 17, 1992~~
NOV 7 1992