

ACCESS SERVICE

(AT)

23.2 AT&T DEDICATED ETHERNET SERVICE

23.2.1 Service Description

(3) Higher Speed Aggregation

Higher Speed Aggregation permits Customers to connect a lower speed AT&T Dedicated Ethernet Port Connection to a channelized higher speed AT&T Dedicated Ethernet Port Connection.

OTU2 (10Gbps) and OTU4 (100Gbps) AT&T Dedicated Ethernet Port Connections may be purchased as either channelized or non-channelized. A channelized Port Connection includes a channelized circuit that terminates at a multiplexer within a serving wire center.

A channelized OTU2 Port Connection can connect up to eight 1GE Port Connections or four OTU1 Port Connections, or any other combination of such Port Connections, up to the available capacity of the channelized OTU2 Port Connection.

A channelized OTU4 Port Connection can connect to up to ten 10Gbps Port Connections in any combination of types (10GE LAN-PHY, 10GE WAN-PHY, OTU2e, or OTU2), up to the available capacity of the channelized OTU4 Port Connection.

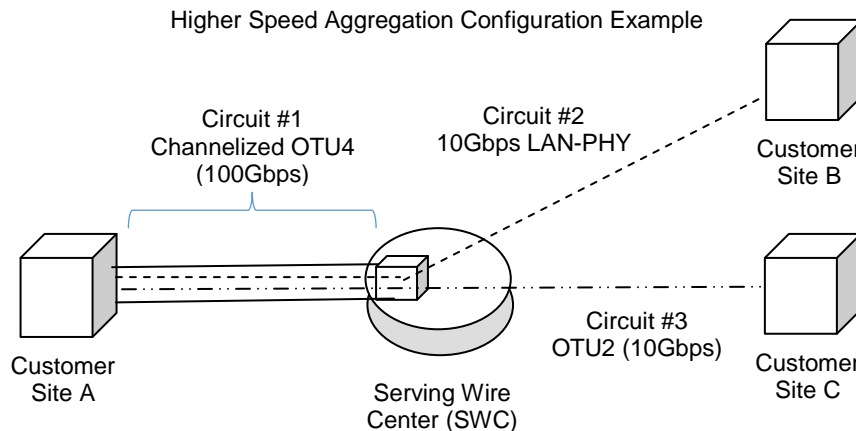

In the example of a higher speed aggregation arrangement depicted in the diagram above, there are three AT&T Dedicated Ethernet circuits, as follows:

1. Circuit #1 = A channelized OTU4 (100Gbps) circuit from Customer Site A that terminates at a multiplexer within the Serving Wire Center.

One OTU4 Port Connection monthly recurring charge applies for Circuit #1.

(AT)

Southwestern Bell Telephone
Company d/b/a AT&T Missouri

ACCESS SERVICE

(AT)

23.2 AT&T DEDICATED ETHERNET SERVICE

23.2.1 Service Description

2. Circuit #2 = A 10Gbps LAN-PHY circuit from Customer Site B to Customer Site A. Circuit #2 occupies a channel of the higher speed Circuit #1 from the Serving Wire Center location to Customer Site A.

One 10GE LAN-PHY Port Connection monthly recurring charge applies to Circuit #2 for the Port Connection at Customer Site B.

No Port Connection charge applies to the portion of Circuit #2 that occupies a channel of Circuit #1 (i.e., SWC to Customer Site A).

3. Circuit #3 = A 10Gbps OTU2 circuit from Customer Site C to Customer Site A. Circuit #3 occupies a channel of the higher speed Circuit #1 from the Serving Wire Center location to Customer Site A.

One OTU2 Port Connection monthly recurring charge applies for Circuit #3 for the Port Connection at Customer Site C.

No Port Connection charge applies to the portion of Circuit #3 that occupies a channel of Circuit #1 (i.e., SWC to Customer Site A).

(AT)

ACCESS SERVICE

23.2 AT&T DEDICATED ETHERNET SERVICE

23.2.1 Service Description

(D) Protection and Diversity Options

Protection and diversity options are available for the AT&T Dedicated Ethernet Service as follows:

Protection Option	Diversity Options
<ul style="list-style-type: none">• Port Protection Plus	<ul style="list-style-type: none">• Port Diversity• Alternate Wire Center Diversity• Inter-Wire Center Diversity

Protection cannot be combined with Diversity options except in the case of a stand-alone Alternate Wire Center Diversity option.

Protection and diversity options are available where facilities and/or operating conditions permit. Where facilities and/or operating conditions do not permit, special construction charges may apply as set forth in Section 14 of this Guidebook.

(1) Protection

Protection offers a duplicate AT&T Dedicated Ethernet Service signal routed on two different fiber pairs (a working path and a standby path) to provide increased reliability.

In the event of a failure of the working path, the AT&T Dedicated Ethernet Service will switch to the surviving path. In the event of a failure of both fiber transmission paths, an out-of-service condition will result.

Limitations:

- Protection is not available for same speed / different format circuit configurations
- Protection is not available for higher speed aggregation configurations (i.e., protection is not available for channelized circuits and circuits connecting with a channelized circuit).
- Protection is not available for Meet Point arrangements. See Section 1.1(E) for more information on Meet Point arrangements.

(a) Port Protection Plus

Port Protection Plus is an end-to-end (fully protected) protection option that offers a duplicate AT&T Dedicated Ethernet Service signal routed over two diversely routed fiber paths, a working path and a standby path, from Customer Site to Customer Site. Port Protection Plus also includes dual card protection at each Customer Site whereby the working path and standby paths terminate into two separate cards on a single shelf in the NTE at each of the Customer Sites.

The Port Protection Plus optional feature must be selected for both Customer Sites in addition to the normal Port Connection charges.

Material previously appeared on this page now appears on 1st Revised Page 39.

(AT)
|
(AT)

ACCESS SERVICE

23.2 AT&T DEDICATED ETHERNET SERVICE

23.2.1 Service Description

(1) Protection (Cont'd)

(a) Port Protection Plus (Cont'd)

Port Protection Plus is available only for AT&T Dedicated Ethernet circuits that meet the following conditions:

- The circuit must be configured as a same speed / same format arrangement;
and
- Neither end of the circuit can terminate at a collocation arrangement

(2) Diversity

Diversity options minimize single points of failure by creating two circuits, or portions of a circuit, that are diverse from one another. With these arrangements, one or more circuits will be provisioned over the normal path and one or more circuits will be provisioned over the diverse path. Customers may transport traffic over both circuits.

Customers requesting diversity will be billed for two circuits plus the applicable diversity charge(s) for the portions of the circuit that are physically diverse.

Diversity options do not include construction of dual entrance facilities. If a Customer desires dual entrance facilities and they do not currently exist, arrangements must be made for constructing dual entrance facilities at the Customer's expense.

Limitations:

- Diversity options are not available for Meet Point arrangements. See Section 1.1(E) for more information on Meet Point arrangements.
- Port Diversity and Alternate Wire Center Diversity cannot be selected at the same Customer Site location for the same AT&T Dedicated Ethernet Service Port Connection.

Material appearing on this page previously appeared on Original Page 38.

(MT)
|
(MT)

(AT)
(AT)

ACCESS SERVICES

23.2 AT&T DEDICATED ETHERNET SERVICE

23.2.1 Service Description

(E) Meet Point Arrangements

(CT)

In some cases, the Telephone Company and another Incumbent Local Exchange Carrier (ILEC, sometimes referred to as an Independent Company or ICO) may agree to jointly provide service where such service will be provided to locations in both the Telephone Company's and the other ILEC's serving territories within the same LATA. In such cases, the Telephone Company and the other ILEC may mutually agree to meet at a location (i.e., meet point) within the LATA utilizing facilities suitable for delivery of AT&T Dedicated Ethernet.

The Telephone Company is responsible for the ordering, provisioning, billing and maintenance of such AT&T Dedicated Ethernet service up to the meet point.

The rates and charges for AT&T Dedicated Ethernet are applicable for the Telephone Company-provided portion of such service as follows:

1. One Port Connection charge applies for the portion of the circuit provided by the Telephone Company.
2. The Administrative Charge applies in full per order received.
3. The Design and Central Office Connection Charge applies in full per AT&T Dedicated Ethernet circuit.
4. The Customer Connection Charge applies for the termination of the Port Connection provided by the Telephone Company.

(CT)

23.2.2 Types of Rates and Charges

(A) Non-recurring Charges

Non-recurring charges are one-time charges that apply for specific work activity (i.e., installation or change to an existing service) related to the provisioning of AT&T Dedicated Ethernet Service. The types of nonrecurring charges that apply for AT&T Dedicated Ethernet Service are:

- (1) Installation of Service: Nonrecurring charges apply to each service installed.
- (2) Installation of Optional Features and Functions: Nonrecurring charges apply for the installation of the optional features and functions available with AT&T Dedicated Ethernet Service. The charge applies whether the feature or function is installed coincident with the initial installation of service or at any time subsequent to the installation of the service.
- (3) Service Rearrangements: Service rearrangements are changes to existing (installed) services which do not result in either:
 - A change in the minimum period of the service, or
 - A change in the physical location of the point of termination at a Customer Site.