

No Supplement to this tariff will be issued except for the purpose of canceling this tariff.

ACCESS SERVICES

14. SPECIAL CONSTRUCTION

This Section contains the regulations, liabilities, rates and charges applicable for special construction of Telephone Company facilities which are used to provide services offered in this and other Southwestern Bell Telephone Company Tariffs.

When special construction of facilities is required, the provisions of this Section apply in addition to all regulations, rates and charges set forth in other Southwestern Bell Tariffs.

14.1 Ownership of Facilities

The Telephone Company retains ownership of all specially constructed facilities.

14.2 Interval to Provide Facilities

Based on available information and the type of service ordered, the Telephone Company will establish a completion date for the specially constructed facilities. The Telephone Company will make every reasonable effort to assure that the date is met. However, shortage of material, personnel or other factors may lengthen the installation interval. The Telephone Company does not guarantee that the facilities will be available on the scheduled date and assumes no liability if that date is missed. If the scheduled completion date cannot be met, the IC will be notified, and a new completion date will be established.

14.3 Payments for Special Construction

14.3.1 Payment of Charges

All bills associated with special construction are due in accordance with the appropriate regulations in the service tariff under which service is being provided.

Issued: December 29, 1983

Effective: January 1, 1984

By R. D. BARRON, Vice President-Missouri
Southwestern Bell Telephone Company
St. Louis, Missouri

No Supplement to this tariff will be issued except for the purpose of canceling this tariff.

Access Services Tariff
Section 14
1st Revised Sheet 2
Replacing Original Sheet 2

ACCESS SERVICES

14. SPECIAL CONSTRUCTION-(Continued)

14.3 Payments for Special Construction-(Continued)

14.3.2 Start/End of Billing

Billing of recurring charges for specially constructed facilities starts on the day after the facilities are made available for use. Billing accrues through and includes the day that the specially constructed facilities are discontinued.

14.3.3 Partial Payments

To safeguard its interests during construction, the Telephone Company may require partial payments(s) for the portion of the estimated cost of the special construction for which a nonrecurring charge will apply. Partial payments may be requested as costs are incurred and will be credited against the total bill. Partial payments may not exceed the total non-recurring charge for the special construction. If any partial payment is not received by the Telephone Company by the end of the first working day of the next month, the Telephone Company will cease all work on the special construction case, and cancellation charges will apply as set forth in Paragraph 14.4.4, F., following.

(CT)

(AT) 14.3.4 Credit Allowance for Service Interruptions

In the event of a service interruption involving a specially constructed facility, the customer shall receive a recurring monthly charge credit in accordance with the credit allowance provisions in the appropriate service tariff associated with the affected services.

When an interruption continues due to the failure of the customer to authorize the replacement of facilities subject to a Replacement Charge, as specified in Paragraph 14.4.4, A.4., following, the credit allowance will be terminated on the seventh calendar day after the Telephone Company has provided the customer with written notification of the need for replacement. The credit allowance will resume on the day after the Telephone Company receives written authorization for the replacement from the customers.

Issued: June 27, 1986 Effective: July 1, 1986

By R. D. BARRON, President-Missouri Division
Southwestern Bell Telephone Company
St. Louis, Missouri

No supplement to this tariff will be issued except for the purpose of canceling this tariff.

Access Services Tariff
Section 14
Original Sheet 2

ACCESS SERVICES

14. SPECIAL CONSTRUCTION-(Continued)

14.3 Payments for Special Construction-(Continued)

14.3.2 Start/End of Billing

Billing of recurring charges for specially constructed facilities starts on the day after the facilities are made available for use. Billing accrues through and includes the day that the specially constructed facilities are discontinued.

14.3.3 Partial Payments

To safeguard its interests during construction, the Telephone Company may require partial payments(s) for the portion of the estimated cost of the special construction for which a nonrecurring charge will apply. Partial payments may be requested as costs are incurred and will be credited against the total bill. Partial payments may not exceed the total nonrecurring charge for the special construction. If any partial payment is not received by the Telephone Company by the end of the first working day of the next month, the Telephone Company will cease all work on the special construction case, and cancellation charges will apply as set forth in Paragraph 14.4, F.

RECEIVED

DEC 29 1983

MISSOURI
Public Service Commission

CANCELLED
JUL 1 1986
BY J.R.S. 2
PUBLIC SERVICE COMMISSION
OF MISSOURI

Issued: DEC 29 1983

Effective: JAN 0 1 1984

By R. D. BARRON, Vice President-Missouri
Southwestern Bell Telephone Company,
St. Louis, Missouri

FILED
JAN - 1 1984
83 - 253
Public Service Commission

No Supplement to this tariff will be issued except for the purpose of canceling this tariff.

Access Services Tariff
Section 14
1st Revised Sheet 3
Replacing Original Sheet 3

ACCESS SERVICES

14. SPECIAL CONSTRUCTION-(Continued)

14.4 Liabilities and Charges for Special Construction

14.4.1 General

(AT) This Section describes the various charges and liabilities that may apply when the Telephone Company provides special construction of facilities in accordance with an order or a customer's projected future requirement for service. Written approval of all liabilities and charges must be provided to the Telephone Company prior to the start of construction.

14.4.2 Conditions Requiring Special Construction

Special construction is required when (1) suitable facilities are not available to meet an order for service, and (2) the Telephone Company constructs facilities and (3) one or more of the following conditions exist:

- The Telephone Company has no other requirement for the facilities constructed.
- It is requested that service be furnished using a type of facility or via a route, other than that which the Telephone Company would normally utilize in furnishing the requested service.
- More facilities are requested than would normally be required to satisfy an order.
- It is requested that construction be expedited, resulting in added cost to the Telephone Company.

14.4.3 Development of Liabilities and Charges

Special construction charges and liabilities will be developed based on estimated costs, except when actual costs are requested in writing prior to start of special construction. In order to meet a scheduled service date when actual costs are requested, an initial special construction case will be made based on estimated costs. Such case will be revised when actual costs are available.

Issued: June 27, 1986

Effective: July 1, 1986

By R. D. BARRON, President-Missouri Division
Southwestern Bell Telephone Company
St. Louis, Missouri

No supplement to this tariff will be issued except for the purpose of canceling this tariff.

Access Services Tariff
Section 14
Original Sheet 3

ACCESS SERVICES

14. SPECIAL CONSTRUCTION-(Continued)

14.4 Liabilities and Charges for Special Construction

14.4.1 General

This Section describes the various charges and liabilities that may apply when the Telephone Company provides special construction of facilities in accordance with an order for service. Written approval of all liabilities and charges must be provided to the Telephone Company prior to the start of construction.

14.4.2 Conditions Requiring Special Construction

Special construction is required when (1) suitable facilities are not available to meet an order for service, and (2) the Telephone Company constructs facilities and (3) one or more of the following conditions exist:

- The Telephone Company has no other requirement for the facilities constructed.
- It is requested that service be furnished using a type of facility or via a route, other than that which the Telephone Company would normally utilize in furnishing the requested service.
- More facilities are requested than would normally be required to satisfy an order.
- It is requested that construction be expedited, resulting in added cost to the Telephone Company.

14.4.3 Development of Liabilities and Charges

Special construction charges and liabilities will be developed based on estimated costs, except when actual costs are requested in writing prior to start of special construction. In order to meet a scheduled service date when actual costs are requested, an initial special construction case will be made based on estimated costs. Such case will be revised when actual costs are available.

CANCELLED

JUL 1 1986
BY MR 5.3
PUBLIC SERVICE COMMISSION
OF MISSOURI

Issued: DEC 29 1983

Effective: JAN 0 1

By R. D. BARRON, Vice President-Missouri
Southwestern Bell Telephone Company
St. Louis, Missouri

RECEIVED

DEC 29 1983

Public Service Commission

FILED
1984 JAN - 1 1984
83 - 253
Public Service Commission

No Supplement to this tariff will be issued except for the purpose of canceling this tariff.

Access Services Tariff
Section 14
Original Sheet 4

ACCESS SERVICES

14. SPECIAL CONSTRUCTION-(Continued)

14.4 Liabilities and Charges for Special Construction-(Continued)

14.4.4 Types of Liabilities and Charges

Depending on the specifics associated with each individual case, one or more of the following special construction charges and/or liabilities may be applicable:

A. Nonrecurring Charge

A nonrecurring charge always applies and includes one or more of the following components:

1. Quotation Charge

A nonrecurring charge for the preparation of a quotation as set forth in Section 2, Paragraph 2.4.3, preceding, applies whenever an estimate for special construction charges and liabilities is requested.

2. Expediting Charge

A nonrecurring charge may include an expediting charge when it is requested that special construction be completed on an expedited basis. The charge equals the difference in estimated cost between expedited and nonexpedited construction.

3. Optional Payment

An optional payment charge may be included in the nonrecurring charge in association with a type of facility or route other than that which the Telephone Company would normally use in furnishing the requested service if lower recurring monthly charges are desired for the specially constructed facilities. This charge is equal to the excess installed cost or the total nonrecoverable cost, whichever is less. This election must be made in writing before special construction starts. If this selection is coupled with the actual cost option, the optional payment charge will reflect the actual cost of the specially constructed facilities.

Issued: December 29, 1983

Effective: January 1, 1984

By R. D. BARRON, Vice President-Missouri
Southwestern Bell Telephone Company
St. Louis, Missouri

No Supplement to this tariff will be issued except for the purpose of canceling this tariff.

ACCESS SERVICES

14. SPECIAL CONSTRUCTION-(Continued)

14.4 Liabilities and Charges for Special Construction-(Continued)

14.4.4 Types of Liabilities and Charges-(Continued)

A. Nonrecurring Charge-(Continued)

4. Replacement Charge

If any portion of specially constructed facilities for which an optional payment charge has been paid requires replacement involving capital investment, a replacement charge will apply. This charge will be in the same ratio to the total replacement cost as the initial optional payment charge was to the installed cost of the original specially constructed facilities. If any portion of the facilities subject to the replacement charge fails, service will not be restored until notification is provided in writing that replacement is required and such replacement is ordered.

5. Rearrangement Charge

If the Telephone Company is requested to rearrange existing specially constructed facilities, a nonrecurring charge component equal to the cost of rearrangement will apply.

6. Special Construction of Facilities for Use for Less Than One Month

When the Telephone Company is requested to construct facilities to provide service for less than one month, a nonrecurring charge only applies. In addition to the quotation preparation charge component, this nonrecurring charge recovers all elements of cost, including engineering, shipping of equipment, equipment installation, line-up, equipment leasing, space rental, equipment removal and any other costs associated with the construction of the facilities.

B. Maximum Termination Liability and Termination Charge

A Maximum Termination Liability is equal to the nonrecoverable costs associated with specially constructed facilities and is the maximum amount which could be applied as a Termination Charge if all specially constructed facilities were discontinued before the Maximum Termination Liability expires.

Issued: December 29, 1983

Effective: January 1, 1984

By R. D. BARRON, Vice President-Missouri
Southwestern Bell Telephone Company
St. Louis, Missouri

No Supplement to this tariff will be issued except for the purpose of canceling this tariff.

ACCESS SERVICES

14. SPECIAL CONSTRUCTION-(Continued)

14.4 Liabilities and Charges for Special Construction-(Continued)

14.4.4 Types of Liabilities and Charges-(Continued)

B. Maximum Termination Liability and Termination Charge-(Continued)

(AT)

The liability period is equal to the average life of the account associated with the specially constructed facilities. When the construction involves multiple classes of plant with differing lives, the liability period is equal to the weighted average of the account lives involved in the special construction case, using nonrecoverable investment as the basis for weighting.

Example

\$20,000, \$10,000 and \$5,000 nonrecoverable investments with average account lives of 8, 18 and 25 years, respectively, are involved in the same special construction case. The maximum termination liability period will be calculated as follows:

20,000	X	8	=	160,000
10,000	X	18	=	180,000
5,000	X	25	=	125,000
35,000				465,000

$$\frac{465,000}{35,000} = 13.3$$

The maximum termination liability period would be 13 years as a result of rounding. Fractional years will be rounded down to the nearest year when they are .4 or lower and rounded up to the nearest year when they are .5 or higher. The liability period is generally expressed in terms of an effective date and expiration date.

(MT)

Issued: June 27, 1986

Effective: July 1, 1986

By R. D. BARRON, President-Missouri Division
Southwestern Bell Telephone Company
St. Louis, Missouri

No supplement to this tariff will be issued except for the purpose of canceling this tariff.

Access Services Tariff
Section 14
Original Sheet 6

ACCESS SERVICES

14. SPECIAL CONSTRUCTION-(Continued)

DEC 29 1983

14.4 Liabilities and Charges for Special Construction-(Continued)

14.4.4 Types of Liabilities and Charges-(Continued)

Public Service Commission

B. Maximum Termination Liability and Termination Charge-(Continued)

The liability period is equal to the average life of the account associated with the specially constructed facilities, except in the case of the Federal Government (see Paragraph 14.6). The liability period is generally expressed in terms of an effective date and expiration date.

A Termination Charge may apply when all services using specially constructed facilities which have a tariffed Maximum Termination Liability are discontinued prior to the expiration of the liability period. The charge reflects the unamortized portion of the nonrecoverable costs at the time of termination, adjusted for net salvage and possible reuse. Administrative costs associated with the specific case of special construction and any cost for restoring a location to its original condition are also included.

C. Annual Underutilization Liability and Underutilization Charge

Annual Underutilization Liability is a per-unit amount which is based on the per-unit cost of specially constructed facilities. The liability remains in effect until the expiration of the Maximum Termination Liability or until the special construction case is discontinued and all termination liabilities associated with the case are discharged. An underutilization charge may be applicable after the expiration of the minimum period, as set forth in the appropriate service tariff, under which service is being provided, depending on the quantity of specially constructed facilities in service.

No underutilization charges are computed or billed until one year after the minimum period expires. At that time, an underutilization charge applies to the difference, if any, between the original number of specially constructed facilities and the number of

CANCELLED

JUL 1 1986

BY R.S. 6
PUBLIC SERVICE COMMISSION
OF MISSOURI

FILED

Issued: DEC 29 1983

Effective: JAN 0 1 1984

JAN - 1 1984

83 - 253

By R. D. BARRON, Vice President-Missouri Public Service Commission
Southwestern Bell Telephone Company
St. Louis, Missouri

No Supplement to this tariff will be issued except for the purpose of canceling this tariff.

Access Services Tariff
Section 14
Original Sheet 6.01

ACCESS SERVICES

14. SPECIAL CONSTRUCTION-(Continued)

14.4 Liabilities and Charges for Special Construction-(Continued)

14.4.4 Types of Liabilities and Charges-(Continued)

B. Maximum Termination Liability and Termination Charge-(Continued)

(MT)
(CT)

The Maximum Termination Liability is calculated in decreasing amounts at ten-year intervals over the average account life of the facilities. In the event that the average account life of the facilities is not an even multiple of ten, the last increment will reflect the appropriate number of years remaining.

Example Illustrating a 27-Year Average Account Life

<u>Maximum Termination Liability</u>	<u>Effective Date</u>	<u>Expiration Date</u>
\$10,000	6/1/84	6/1/94
7,000	6/1/94	6/1/04
3,000	6/1/04	6/1/11

Prior to the expiration of each liability period, the customer has the option to (A) terminate the special construction case and pay the appropriate charges, or (B) extend the use of the specially constructed facilities for the new liability period.

The Telephone Company will notify the customer six months in advance of the expiration date of each ten-year liability period. The customer must provide the Telephone Company with written notification at least 30 days prior to the expiration of the liability period if termination is elected. Failure to do so will result in an automatic extension of the special construction case to the next liability period at the filed Maximum Termination Liability amount.

Issued: June 27, 1986 Effective: July 1, 1986

By R. D. BARRON, President-Missouri Division
Southwestern Bell Telephone Company
St. Louis, Missouri

No Supplement to this tariff will be issued except for the purpose of canceling this tariff.

14. SPECIAL CONSTRUCTION-(Continued)

14.4 Liabilities and Charges for Special Construction-(Continued)

14.4.4 Types of Liabilities and Charges-(Continued)

B. Maximum Termination Liability and Termination Charge-(Continued)

(MT) A Termination Charge may apply when all services using specially constructed facilities which have a Maximum Termination Liability are discontinued prior to the expiration of the liability period. The charge reflects the unamortized portion of the nonrecoverable costs at the time of termination, adjusted for net salvage and possible reuse. Administrative costs associated with the specific case of special construction and any cost for restoring a location to its original condition are also included. A Termination Charge may never exceed the Maximum Termination Liability.

(AT)

(AT) A partial termination of specially constructed facilities will be provided, at the election of the customer. The amount of the Termination Charge associated with such partial termination is determined by multiplying the termination charge which would result if all services using the specially constructed facilities were discontinued, at the time partial termination is elected, by the percentage of specially constructed facilities to be partially terminated. The customer will be informed of the remaining Maximum Termination Liability amounts and the number of specially constructed facilities the customer will remain liable for.

Example:

A customer with a Maximum Termination Liability of \$100,000 for 3600 specially constructed facilities request a partial termination of 900 facilities. The Termination Charge for all facilities, at the time of election, is \$60,000. The partial termination charge, in this example, is \$60,000 x 900/3600, or \$15,000.

(CT) C. Annual Underutilization Liability and Underutilization Charge

In certain instances, a customer may request the Telephone Company to construct facilities based upon the customer's projected future requirements. These facilities will be utilized for the provision of services over a specified period of time. Underutilization liabilities will apply when these conditions occur.

Issued: June 27, 1986

Effective: July 1, 1986

By R. D. BARRON, President-Missouri Division
Southwestern Bell Telephone Company
St. Louis, Missouri

No Supplement to this tariff will be issued except for the purpose of canceling this tariff.

ACCESS SERVICES

14. SPECIAL CONSTRUCTION-(Continued)

14.4 Liabilities and Charges for Special Construction-(Continued)

14.4.4 Types of Liabilities and Charges-(Continued)

C. Annual Underutilization Liability and Underutilization Charge (Continued)

Prior to the start of special construction, the Telephone Company and the customer will agree on (1) the quantity of facilities to be provided, and (2) the length of the planning period during which the customer expects to place the facilities in service. The planning period is hereinafter referred to as the Initial Liability Period (ILP). The ILP will have an effective and expiration date.

Underutilization occurs only if, at the expiration date of the ILP and annually thereafter, less than 70 percent of the specially constructed facilities are in service at filed tariff service rates.

An annual underutilization liability amount is filed on a per unit basis (e.g., per cable pair) for each case of special construction. This amount is equal to the annual per unit cost and includes depreciation, maintenance, administration, return, taxes and any other costs identified in the supporting documentation.

Upon the expiration of the ILP, the number of underutilized facilities, if any, are multiplied by the annual underutilization liability amount. This product is then multiplied by the number of years (including any fraction thereof) in the ILP to determine the underutilization charge.

Annually thereafter, the number of underutilized facilities, if any, existing on the anniversary of the ILP expiration date will be multiplied by the annual underutilization liability amount to determine the underutilization charge for the preceding 12-month period.

Example

A customer orders 100 services and the special construction of a 600-pair building riser cable is agreed to, based on the customer's five-year facility requirements. The ILP, in this example, would be five years. The annual underutilization liability is determined to be \$2.00 per pair. If 400 pairs were in service at the end of the ILP, there would be an underutilization of 20 pairs, i.e., $420 (70\% \text{ of } 600) - 400 = 20$. The total underutilization charge for the first 5 years would be \$200.00, or $\$2.00 \text{ per pair} \times 20 \text{ pairs} \times 5 \text{ years}$. If 420 pairs are in service at the end of the 6th year, there is no underutilization, i.e., $420 - 420 = 0$.

Issued: June 27, 1986

Effective: July 1, 1986

By R. D. BARRON, President-Missouri Division
Southwestern Bell Telephone Company
St. Louis, Missouri

No Supplement to this tariff will be issued except for the purpose of canceling this tariff.

Access Services Tariff
Section 14
1st Revised Sheet 7
Replacing Original Sheet 7

ACCESS SERVICES

14. SPECIAL CONSTRUCTION-(Continued)

14.4 Liabilities and Charges for Special Construction-(Continued)

14.4.4 Types of Liabilities and Charges-(Continued)

(RT)

D. Recurring Monthly Charges

1. Excess Capacity Charge

A recurring monthly excess capacity charge applies when more facilities are requested and subsequently specially constructed than are required to satisfy an order for service. The charge is based on the estimated cost difference between the facilities constructed and the facilities which would normally be required to meet the order for service. Charges apply until there are sufficient services to warrant the facilities which were originally constructed.

2. Charge for Route or Type Other than Normal

When special construction is requested using a route or type of facility other than that which the Telephone Company would normally use, a recurring monthly charge in addition to the monthly rates for service is applicable. The charge is equal to the difference between the recurring costs of the specially constructed facilities and the recurring costs of the facilities the Telephone Company would have normally used.

(a) When an Optional Payment Charge as set forth in Paragraph 14.4.4, A.3., preceding, has been elected, the recurring monthly charge will include specially constructed facility operating expenses only.

(AT)

Issued: June 27, 1986

Effective: July 1, 1986

By R. D. BARRON, President-Missouri Division
Southwestern Bell Telephone Company
St. Louis, Missouri

No supplement to this tariff will be issued except for the purpose of canceling this tariff.

Access Services Tariff
Section 14
Original Sheet 7

ACCESS SERVICES

DEC 29 1983

14. SPECIAL CONSTRUCTION-(Continued)

14.4 Liabilities and Charges for Special Construction-(Continued)

Public Service Commission

14.4.4 Types of Liabilities and Charges-(Continued)

C. Annual Underutilization Liability and Underutilization Charge-(Continued)

specially constructed facilities in service at filed Tariff rates. The underutilization charge applies from the date the minimum period expires and annually thereafter. For purposes of determining an underutilization charge, any facilities subject to minimum service period monthly charges are considered to be in service at filed Tariff rates.

D. Recurring Monthly Charges

1. Excess Capacity Charge

A recurring monthly excess capacity charge applies when more facilities are requested and subsequently specially constructed than are required to satisfy an order for service. The charge is based on the estimated cost difference between the facilities constructed and the facilities which would normally be required to meet the order for service. Charges apply until there are sufficient services to warrant the facilities which were originally constructed.

2. Charge for Route or Type Other than Normal

When special construction is requested using a route or type of facility other than that which the Telephone Company would normally use, a recurring monthly charge in addition to the monthly rates for service is applicable. The charge is equal to the difference between the recurring costs of the specially constructed facilities and the recurring costs of the facilities the Telephone Company would have normally used.

(a) When an Optional Payment Charge as set forth in Paragraph 14.4.4, A., preceding, has been elected, the recurring monthly charge will include specially constructed facility operating expenses only.

BY 1st R.S. 7
PUBLIC SERVICE COMMISSION
OF MISSOURI

FILED
JAN - 1 1984
83 - 253
Public Service Commission

Issued: DEC 29 1983

Effective: JAN 0 1 1984

By R. D. BARRON, Vice President-Missouri
Southwestern Bell Telephone Company
St. Louis, Missouri

No Supplement to this tariff will be issued except for the purpose of canceling this tariff.

ACCESS SERVICES

14. SPECIAL CONSTRUCTION-(Continued)

14.4 Liabilities and Charges for Special Construction-(Continued)

14.4.4 Types of Liabilities and Charges-(Continued)

D. Recurring Monthly Charges-(Continued)

2. Charge for Route or Type Other than Normal-(Continued)

(b) If the actual cost option has been elected, the recurring charge will be adjusted to reflect the actual cost of the new construction when the costs have been determined. This adjusted recurring charge is applicable from the start of service.

E. Lease Charge

This charge applies when the Telephone Company leases equipment in order to meet service requirements. The amount of the charge is equal to the net added cost to the Telephone Company caused by the lease.

F. Cancellation Charge

If a service order with which special construction is associated is cancelled prior to the start of service, a Cancellation Charge will apply. The charge will include all nonrecoverable costs incurred by the Telephone Company in association with the special construction up to and including the time of cancellation.

14.5 Deferral of Start of Service

The Telephone Company may be requested to defer the start of service which will use specially constructed facilities subject to the provisions set forth in the service tariff under which service is being provided. Requests for special construction deferral must be in writing and are subject to the following regulations:

14.5.1 Construction Has Not Begun

If the Telephone Company has not incurred any installation costs before receiving a request for deferral, the quotation charge applies. The original quotation is subject to Telephone Company review at the time of reinstatement to determine if the original charge estimates are still valid.

Issued: December 29, 1983 Effective: January 1, 1984

By R. D. BARRON, Vice President-Missouri
Southwestern Bell Telephone Company
St. Louis, Missouri

No Supplement to this tariff will be issued except for the purpose of canceling this tariff.

Access Services Tariff
Section 14
1st Revised Sheet 9
Replacing Original Sheet 9

ACCESS SERVICES

14. SPECIAL CONSTRUCTION-(Continued)

14.5 Deferral of Start of Service-(Continued)

14.5.1 Construction Has Not Begun-(Continued)

An additional quotation charge will, therefore, apply. Any change in liabilities and charges requires concurrence in writing.

14.5.2 Construction Has Begun

If the construction of facilities has begun before the Telephone Company receives a request for deferral, charges will vary as follows:

A. All Services Are Deferred

When all services which will use specially constructed facilities are deferred, a charge based on the costs incurred by the Telephone Company during each month of the deferral will apply. Those costs include the recurring costs for that portion of the facilities already completed and any other costs associated with the deferral. The quotation charge and cost of any components of the nonrecurring charge which have been completed at the time of deferral will also apply.

B. Some Services Are Deferred

When some services which will use the specially constructed facilities are deferred, the construction case will be completed and all special construction charges will apply.

14.5.3 Construction Complete

If the construction of facilities has been completed before the Telephone Company receives a request for deferral, all special construction charges will apply.

(RT)

Issued: June 27, 1986

Effective: July 1, 1986

By R. D. BARRON, President-Missouri Division
Southwestern Bell Telephone Company
St. Louis, Missouri

No supplement to this tariff will be issued except for the purpose of canceling this tariff.

Access Services Tariff
Section 14
Original Sheet 9

ACCESS SERVICES

RECEIVED

14. SPECIAL CONSTRUCTION-(Continued)

DEC 29 1983

14.5 Deferral of Start of Service-(Continued)

14.5.1 Construction Has Not Begun-(Continued)

MISSOURI

Public Service Commission

An additional quotation charge will, therefore, apply. Any change in liabilities and charges requires concurrence in writing.

14.5.2 Construction Has Begun

If the construction of facilities has begun before the Telephone Company receives a request for deferral, charges will vary as follows:

A. All Services Are Deferred

When all services which will use specially constructed facilities are deferred, a charge based on the costs incurred by the Telephone Company during each month of the deferral will apply. Those costs include the recurring costs for that portion of the facilities already completed and any other costs associated with the deferral. The quotation charge and cost of any components of the nonrecurring charge which have been completed at the time of deferral will also apply.

B. Some Services Are Deferred

When some services which will use the specially constructed facilities are deferred, the construction case will be completed and all special construction charges will apply.

14.5.3 Construction Complete

If the construction of facilities has been completed before the Telephone Company receives a request for deferral, all special construction charges will apply.

14.6 Regulations for Federal Government

Special construction provided to the Government is subject to all regulations specified in Paragraphs 14.1 through 14.5, preceding, and Paragraph 14.6, following. In lieu of filed Maximum Termination

CANCELLED
JUL 1 1986
BY R.S.9
PUBLIC SERVICE COMMISSION
OF MISSOURI

FILED
83-253
Public Service Commission

Issued: DEC 29 1983

Effective: JAN 01 1984 - 1 1984

By R. D. BARRON, Vice President-Missouri
Southwestern Bell Telephone Company
St. Louis, Missouri

No Supplement to this
tariff will be issued
except for the purpose
of canceling this tariff.

Access Services Tariff
Section 14
1st Revised Sheet 10
Replacing Original Sheet 10

ACCESS SERVICES

(RESERVED FOR FUTURE USE)

(RT)

Issued: June 27, 1986 Effective: July 1, 1986

By R. D. BARRON, President-Missouri Division
Southwestern Bell Telephone Company
St. Louis, Missouri

No supplement to this tariff will be issued except for the purpose of canceling this tariff.

Access Services Tariff
Section 14
Original Sheet 10

RECEIVED

ACCESS SERVICES

DEC 29 1983

14. SPECIAL CONSTRUCTION-(Continued)

14.6 Regulations for Federal Government-(Continued)

MISSOURI
Public Service Commission

Liability Period equal to the average account life of the specially constructed facilities, the Maximum Termination Liability will be filed at ten-year intervals for the average account life of the facilities. In the event that the average account life of the facilities is not an even multiple of ten, the last increment filed will reflect the appropriate number of years remaining (e.g., 7 years for plant with a 27-year life).

Prior to the expiration of each liability period, the Government has the option to (A) extend the use of specially constructed facilities for the new liability period or (B) terminate the special construction case and pay the appropriate charges.

The Telephone Company will notify the Government six months in advance of the expiration date that the special construction case is subject to renewal. The Government must provide the Telephone Company with written notification of termination, to be received one month prior to the expiration of the liability period. Failure to do so and payment of the next month's service charges will result in an extension of the special construction case for the next ten-year interval.

A. Continued Use of Special Construction

When the Government elects to continue the case of special construction, a revised nonrecurring charge, Maximum Termination Liability and Maximum Termination Liability Period will be filed.

B. Termination of the Use of Special Construction

When the Government elects to terminate a case of special construction at or prior to the expiration of the current liability period, Termination Charges will apply.

In order to comply with Government regulations, a quotation charge will not apply when submitting unsolicited quotes or when submitting quotes in response to a general Request for Proposal or Invitation to Bid from agencies or branches of the Government.

CANCELLED

JUL 1 1986

BY Let R S. 10
PUBLIC SERVICE COMMISSION
OF MISSOURI

Issued: DEC 29 1983

Effective: JAN 0 1 1984

FILED
1984 JAN - 1 1984
83 - 253
Public Service Commission

By R. D. BARRON, Vice President-Missouri
Southwestern Bell Telephone Company
St. Louis, Missouri

No Supplement to this tariff will be issued except for the purpose of canceling this tariff.

Access Services Tariff
Section 15
4th Revised Sheet 1
Replacing 3rd Revised Sheet 1

(RT)

(AT)

INTRALATA DIALING PARITY COST RECOVERY

(AT)

INTRALATA DIALING PARITY COST RECOVERY, Section 15 of the Access Services Tariff, P.S.C. Mo.-No. 36, has been withdrawn, in its entirety, and the contents completely removed.

Issued: March 11, 2004

Effective: April 11, 2004

By CINDY BRINKLEY, President-SBC Missouri
Southwestern Bell Telephone, L.P., d/b/a SBC Missouri
St. Louis, Missouri

No Supplement to this tariff will be issued except for the purpose of canceling this tariff.

Access Services Tariff
Section 15
3rd Revised Sheet 1
Replacing 2nd Revised Sheet 1

(AT) 15. INTRALATA DIALING PARITY COST RECOVERY

Missouri Public Service Commission

15.1 General Description

REC'D AUG 07 2000

The IntraLATA Equal Access Cost Recovery Charge is an originating per minute of use charge to recover cost that the Telephone Company incurred with the implementation of intraLATA dialing parity. The charge will be in effect until the Telephone Company recovers its intraLATA dialing parity costs pursuant to the Missouri Public Service Commission Order in Case No. TO-99-535 (In the Matter of Southwestern Bell Telephone Company's IntraLATA Long Distance Dialing Parity Plan). The charge is estimated to be in effect for a three year period.

15.2 Rate Regulations

The IntraLATA Equal Access Cost Recovery Charge is assessed to the customer based on Intrastate originating access minutes. The rate is set forth in 15.3, following.

15.3 Rates and Charges

Equal Access Cost Recovery Charge

Access rate per minute of use
- Originating

\$0.001273

(AT)

CANCELLED

APR 11 2004

By *HR* / *RS* /
Public Service Commission
MISSOURI

Missouri Public Service Commission

01-096

FILED OCT 04 2000

Issued: August 7, 2000

Effective: ~~September 6, 2000~~

By JAN NEWTON, President-Missouri
Southwestern Bell Telephone Company
St. Louis, Missouri

OCT 04 2000

No supplement to this tariff will be issued except for the purpose of canceling this tariff.

Access Services Tariff
Section 15
2nd Revised Sheet 1
Replacing 1st Revised Sheet 1

ACCESS SERVICES

RECEIVED

SEP 22 1994

MO. PUBLIC SERVICE COMM.

(RT) 15.

(RT)

CANCELLED

OCT 04 2000

By

3rd RS 1

Public Service Commission
MISSOURI

FILED

OCT - 1 1994
95 - 85

MISSOURI
Public Service Commission

Issued: SEP 22 1994

Effective: ~~OCT 01 1994~~

By HORACE WILKINS, JR., President-Missouri OCT 01 1994
Southwestern Bell Telephone Company
St. Louis, Missouri

No supplement to this tariff will be issued except for the purpose of canceling this tariff.

Access Services Tariff
Section 15
2nd Revised Sheet 1
Replacing 1st Revised Sheet 1

ACCESS SERVICES

(RT) 15.

RECEIVED

DEC 23 1993

**MISSOURI
Public Service Commission**

(RT)

CANCELLED

OCT 1 1994
BY 9500193
TR-95-85
Public Service Commission
MISSOURI

FILED

JAN 1 1994
93 - 224
MISSOURI

Issued:

DEC 23 1993

Effective:

JAN 01 1994

Public Service Commission

By M. H. SCHULTEIS, Division Manager-Regulatory & Industry Relations
Southwestern Bell Telephone Company
St. Louis, Missouri

No supplement to this tariff will be issued except for the purpose of canceling this tariff.

Access Services Tariff
Section 15
1st Revised Sheet 1
Replacing Original Sheet 1

ACCESS SERVICES

RECEIVED

MAR 29 1993

MISSOURI
Public Service Commission

15. EQUAL ACCESS RECOVERY

15.1 General Description

Equal Access Recovery Charge is a monthly charge assessed to Interexchange Customers (ICs) to recover those costs that the Telephone Company incurs in connection with equal access. Equal Access costs represent the cost of equipping switching machines to provide Feature Group D or BSA-D.

(AT)

15.2 Rate Regulations

The Equal Access Recovery Charge is based on the total number of access trunks provided to the customer. The rate applies to each Feature Group D or BSA-D trunk provided.

(AT)

(AT)

(FC)

The number of end office switching transmission paths (FGD or BSA-D trunks) provided when the customer orders busy hours minutes of capacity will be determined as set forth in Section 6, Paragraph 6.8.5., preceding.

15.3 Rates and Charges

Monthly Rate

Equal Access Recovery,
per trunk:

\$25.57

CANCELLED

OCT 01 1994

BY 2nd R.S.#1

Public Service Commission
MISSOURI

FILED

APR 11 1993

02 - 304

MO. PUBLIC SERVICE COMM.

Issued:

MAR 26 1993

Effective:

APR 11 1993

By R. D. BARRON, President-Missouri Division
Southwestern Bell Telephone Company
St. Louis, Missouri

No supplement to this tariff will be issued except for the purpose of canceling this tariff.

ACCESS SERVICES

15. EQUAL ACCESS RECOVERY

15.1 General Description

Equal Access Recovery Charge is a monthly charge assessed to Interexchange Customers (ICs) to recover those costs that the Telephone Company incurs in connection with equal access. Access Costs represent the cost of equipping switching machines to provide Feature Group D.

RECEIVED
JUN 27 1986
MISSOURI
Public Service Commission

15.2 Rate Regulations

The Equal Access Recovery Charge is based on the total number of access trunks provided to the customer. The rate applies to each Feature Group D trunk provided.

The number of end office switching transmission paths (FG D trunks) provided when the customer orders busy hours minutes of capacity will be determined as set forth in Section 6, Paragraph 6.5.5., preceding.

15.3 Rates and Charges

	<u>Monthly Rate</u>
Equal Access Recovery, per trunk:	\$25.57

CANCELLED
APR 11 1993
BY 1st R.S. #1
Public Service Commission
MISSOURI

FILED
JUN 27 1986
86-84
Public Service Commission

Issued: JUN 27 1986

Effective: JUL 1 1986

By R. D. BARRON, President-Missouri Division
Southwestern Bell Telephone Company
St. Louis, Missouri

No Supplement to this tariff will be issued except for the purpose of canceling this tariff.

Access Services Tariff
Section 16
4th Revised Sheet 1
Replacing 3rd Revised Sheet 1

ACCESS SERVICE

16. PACKET SERVICE

The following list matches the Telephone Company's Basic Service Element BSE names to the industry standard names for each BSE.

<u>Telephone Company Names</u>	<u>Generic Name of ONA Service</u>
Reports	Call Detail Recording Reports
Restricted User Group	Closed User Groups - Packet

Packet Services utilize separate data networks, comprised of switching and transmission facilities. The networks provide for the transfer of protocol oriented data. The data is separated into discrete segments for high speed transmission through the packet networks.

There is one type of Packet Service offered by Southwestern Bell Telephone Company:

(AT) MicroLink II Service⁽¹⁾

(AT) (1) This service is only available to existing MicroLink II - Packet Switching Digital Service (X.25) customers in existing quantities at existing locations. The service will be withdrawn November 30, 2002.
(AT)

Issued: November 7, 2001

Effective: December 7, 2001

By JAN NEWTON, President-Missouri
Southwestern Bell Telephone Company
St. Louis, Missouri

No Supplement to this tariff will be issued except for the purpose of canceling this tariff.

Access Services Tariff

Section 16

3rd Revised Sheet 1

Replacing 2nd Revised Sheet 1

ACCESS SERVICES

Missouri Public Service Commission

16. PACKET SERVICE

REC'D OCT 13 2000

The following list matches the Telephone Company's Basic Service Element BSE names to the industry standard names for each BSE.

Telephone Company Names

Generic Name of ONA Service

Reports

Call Detail Recording Reports

Restricted User Group

Closed User Groups - Packet

Packet Services utilize separate data networks, comprised of switching and transmission facilities. The networks provide for the transfer of protocol oriented data. The data is separated into discrete segments for high speed transmission through the packet networks.

(CT) There is one type of Packet Service offered by Southwestern Bell Telephone Company:

MicroLink II Service

(RT)

CANCELLED

DEC 07 2001

By *44RS1*
Public Service Commission
MISSOURI

Missouri Public Service Commission

FILED MAR 08 2000

Issued: October 13, 1999

Effective: December 14, 1999

By JAN NEWTON, President-Missouri
Southwestern Bell Telephone Company
St. Louis, Missouri

MAR 08 2000

No supplement for this tariff will be issued except for the purpose of canceling this tariff.

Access Services Tariff
Section 16
2nd Revised Sheet 1
Replacing 1st Revised Sheet 1

RECEIVED

ACCESS SERVICES

MAY 24 1994

(CT) 16. PACKET SERVICE

The following list matches the Telephone Company's Basic Service Element BSE names to the industry standard names for each BSE.

MISSOURI
Public Service Commission

<u>Telephone Company Names</u>	<u>Generic Name of ONA Service</u>
Reports	Call Detail Recording Reports
Restricted User Group	Closed User Groups - Packet

(AT)

Packet Services utilize separate data networks, comprised of switching and transmission facilities. The networks provide for the transfer of protocol oriented data. The data is separated into discrete segments for high speed transmission through the packet networks.

There are two types of Packet Service:

- MicroLink II Service
- Frame Relay Service (FRS)

(AT)

CANCELLED

MAR 08 2000

By 3rd RSI
Public Service Commission
MISSOURI

FILED

JUL 15 1994

MISSOURI

Issued:

MAY 24 1994

Effective:

~~JUN 24 1994~~

MISSOURI
Public Service Commission

By M. H. SCHULTEIS, Division Manager-Regulatory & Industry Relations
Southwestern Bell Telephone Company
St. Louis, Missouri

No supplement for this tariff will be issued except for the purpose of canceling this tariff.

Access Services Tariff
Section 16
1st Revised Sheet
Replacing Original Sheet 1
MAR 29 1993

ACCESS SERVICES

16. CONNECTION WITH MICROLINK IISM - PACKET SWITCHING DIGITAL SERVICE MISSOURI
Public Service Commission

The following list matches the Telephone Company's Basic Service Element BSE names to the industry standard names for each BSE.

<u>Telephone Company Names</u>	<u>Generic Name of ONA Service</u>
Reports	Call Detail Recording Reports (Packet)
Restricted User Group	Closed User Groups - Packet

(MT)

CANCELLED

JUL 15 1994
BY *J.R.S. #1*
Public Service Commission
MISSOURI

FILED

APR 11 1993
92 - 304
MO. PUBLIC SERVICE COMM.

Issued: MAR 26 1993

Effective:

APR 11 1993

By R. D. BARRON, President-Missouri Division
Southwestern Bell Telephone Company
St. Louis, Missouri

No supplement to this tariff will be issued except for the purpose of canceling this tariff.

Access Services Tariff
Section 16
Original Sheet 1

RECEIVED
JUL 11 1986
MISSOURI
Public Service Commission

ACCESS SERVICES

16. CONNECTION WITH MICROLINK IISM - PACKET SWITCHING DIGITAL SERVICE

16.1 Service Description

- A. An arrangement that allows a Voice Grade or Digital Data Access Service provided from Section 7 of this Tariff to be connected with MICROLINK II - Packet Switching Digital Service located on a Telephone Company premises. The interfaces are compatible with X.25 and X.75 packet switching protocols as defined by the Consultative Committee for International Telephone and Telegraph (CCITT). This committee establishes standards for packet switching networks to ensure compatibility.
- B. This arrangement permits a Voice Grade Service, a 9.6 Kbps or 56.0 Kbps Digital Data Service to interface with a packet switch port.
- C. Local MICROLINK II - Packet Switching Digital Service charges as specified in the Digital Link Service Tariff.

CANCELLED
APR 11 1993
BY et R.S #1
Public Service Commission
MISSOURI

16.2 Rate Regulations

Rate regulations found in this Tariff are applicable to the Voice Grade or Digital Data Special Access Service. Rate regulations for MICROLINK II - Packet Switching Digital Service may be found in the Missouri Digital Link Services Tariff.

When Special Access is provided with MICROLINK II - Packet Switching Digital Service, the applicable rate elements are a Channel Termination (CT) between the customer premises and its serving wire center and Optional Features and Functions, where applicable. When the customer's serving wire center is outside the Primary Market Area, the Channel Mileage (CM) rate element will be charged in addition to the CT and Optional Feature rate elements.

RECEIVED
NOV 17 1986
Public Service Commission

SMService Mark of Southwestern Bell Telephone Company.

Issued: JUL 15 1986 Effective: NOV 17 1986
~~JUL 15 1986~~

By R. D. BARRON, President-Missouri Division
Southwestern Bell Telephone Company
St. Louis, Missouri

No Supplement to this tariff will be issued except for the purpose of canceling this tariff.

Access Services Tariff
Section 16
2nd Revised Sheet 2
Replacing 1st Revised Sheet 2

ACCESS SERVICE

16. PACKET SERVICE-(Continued)

(AT) 16.1 MicroLink II^R Service⁽¹⁾

16.1.1 Service Description

- A. An arrangement that allows a Voice Grade or Digital Data Special Access Service provided from Section 7 of this Tariff to be connected with MICROLINK II - Packet Switching Digital Service located on a Telephone Company premises. The interfaces are compatible with X.25 and X.75 packet switching protocols as defined by the Consultative Committee for International Telephone and Telegraph (CCITT). This committee establishes standards for packet switching networks to ensure compatibility.
- B. This arrangement permits a Voice Grade Service, a 9.6 Kbps or 56.0 Kbps Digital Data Service to interface with a packet switching port.
- C. Local MICROLINK II - Packet Switching Digital Service charges are as specified in the Digital Link Service Tariff.

16.1.2 Rate Regulations

Rate regulations found in this Tariff are applicable to the Voice Grade or Digital Data Special Access Service. Rate regulations for MICROLINK II - Packet Switching Digital Service may be found in the Missouri Digital Link Services Tariff.

When Special Access is provided with MICROLINK II - Packet Switching Digital Service, the applicable rate elements are a Channel Termination between the customer premises and its serving wire center and Optional Features, BSEs and Functions, where applicable. When the customer's serving wire center is outside the Primary Market Area, the Channel Mileage (CM) rate element will be charged in addition to the CT and Optional Feature and BSE rate elements.

(AT) (1) This service is only available to existing MicroLink II - Packet Switching Digital Service (X.25) customers in existing quantities at existing locations. The service will be withdrawn November 30, 2002.
(AT)

^RRegistered Service Mark of Southwestern Bell Telephone Company

Issued: November 7, 2001

Effective: December 7, 2001

By JAN NEWTON, President-Missouri
Southwestern Bell Telephone Company
St. Louis, Missouri

No supplement for this tariff will be issued except for the purpose of canceling this tariff.

Access Services Tariff
Section 16
1st Revised Sheet 2
Replacing Original Sheet 2

ACCESS SERVICES

RECEIVED

MAY 24 1994

MISSOURI
Public Service Commission

(CT) 16. PACKET SERVICE--(Continued)

(AT) 16.1 MicroLink II^R Service

(FC) 16.1.1 Service Description

- A. An arrangement that allows a Voice Grade or Digital Data Special Access Service provided from Section 7 of this Tariff to be connected with MICROLINK II - Packet Switching Digital Service located on a Telephone Company premises. The interfaces are compatible with X.25 and X.75 packet switching protocols as defined by the Consultative Committee for International Telephone and Telegraph (CCITT). This committee establishes standards for packet switching networks to ensure compatibility.
- B. This arrangement permits a Voice Grade Service, a 9.6 Kbps or 56.0 Kbps Digital Data Service to interface with a packet switching port.
- C. Local MICROLINK II - Packet Switching Digital Service charges are as specified in the Digital Link Service Tariff.

(FC) 16.1.2 Rate Regulations

Rate regulations found in this Tariff are applicable to the Voice Grade or Digital Data Special Access Service. Rate regulations for MICROLINK II - Packet Switching Digital Service may be found in the Missouri Digital Link Services Tariff.

When Special Access is provided with MICROLINK II - Packet Switching Digital Service, the applicable rate elements are a Channel Termination (CT) between the customer premises and its serving wire center and Optional Features, BSEs and Functions, where applicable. When the customer's serving wire center is outside the Primary Market Area, the Channel Mileage (CM) rate element will be charged in addition to the CT and Optional Feature and BSE rate elements.

CANCELLED

DEC 07 2001
By *AndRS2*
Public Service Commission
MISSOURI

FILED

(CT) ^RRegistered Service Mark of Southwestern Bell Telephone Company JULY 15 1994

Issued: **MAY 24 1994** Effective: ~~MISSOURI~~ ~~Public Service Commission~~

By M. H. SCHULTEIS, Division Manager-Regulatory & Industry Relations
Southwestern Bell Telephone Company
St. Louis, Missouri

No supplement for this tariff will be issued except for the purpose of canceling this tariff.

Access Services Tariff
Section 16
Original Sheet 2

ACCESS SERVICES

RECEIVED

MAR 29 1993

MISSOURI
Public Service Commission

(MT) 16. CONNECTION WITH MICROLINK IISM - PACKET SWITCHING DIGITAL SERVICE-(Continued)

16.1 Service Description

- A. An arrangement that allows a Voice Grade or Digital Data Special Access Service provided from Section 7 of this Tariff to be connected with MICROLINK II - Packet Switching Digital Service located on a Telephone Company premises. The interfaces are compatible with X.25 and X.75 packet switching protocols as defined by the Consultative Committee for International Telephone and Telegraph (CCITT). This committee establishes standards for packet switching networks to ensure compatibility.
- B. This arrangement permits a Voice Grade Service, a 9.6 Kbps or 56.0 Kbps Digital Data Service to interface with a packet switching port.
- C. Local MICROLINK II - Packet Switching Digital Service charges are as specified in the Digital Link Service Tariff.

16.2 Rate Regulations

Rate regulations found in this Tariff are applicable to the Voice Grade or Digital Data Special Access Service. Rate regulations for MICROLINK II - Packet Switching Digital Service may be found in the Missouri Digital Link Services Tariff.

When Special Access is provided with MICROLINK II - Packet Switching Digital Service, the applicable rate elements are a Channel Termination (CT) between the customer premises and its serving wire center and Optional Features, BSEs and Functions, where applicable. When the customer's serving wire center is outside the Primary Market Area, the Channel Mileage (CM) rate element will be charged in addition to the CT and Optional Feature and BSE rate element.

(AT)

(MT)(AT)

CANCELLED
JUL 15 1994
BY 1st R.S. #2
Public Service Commission
MISSOURI

FILED

APR 11 1993
92-304
MO. PUBLIC SERVICE COMM.

SMService Mark of Southwestern Bell Telephone Company

Issued: MAR 26 1993

Effective:

APR 11 1993

By R. D. BARRON, President-Missouri Division
Southwestern Bell Telephone Company
St. Louis, Missouri

No Supplement to this tariff will be issued except for the purpose of canceling this tariff.

Access Services Tariff
Section 16
1st Revised Sheet 3
Replacing Original Sheet 3

ACCESS SERVICES

16. PACKET SERVICE-(Continued)

(RT)

(RT)

Issued: October 13, 1999

Effective: March 8, 2000

By JAN NEWTON, President-Missouri
Southwestern Bell Telephone Company
St. Louis, Missouri

CANCELLED
June 29, 2007
TO-2002-185
Missouri Public
Service Commission

FILED
Missouri Public
Service Commission

No supplement for this tariff will be issued except for the purpose of canceling this tariff.

Access Services Tariff
Section 16
Original Sheet 3

ACCESS SERVICES

RECEIVED

16. PACKET SERVICE-(Continued)

MAY 24 1994

16.2 Frame Relay Service (FRS)

MISSOURI
Public Service Commission

16.2.1 General Description

Frame Relay Service (FRS) provides the customer high speed access and throughput to and among the customer locations. Utilizing statistical multiplexing, FRS enables the customer to allocate circuit bandwidth to applications as needed, up to the maximum bandwidth purchased, rather than assigning fixed channels to specific applications.

FRS is available to customers within LATAs served by the Telephone Company and is provisioned from suitably equipped wire centers located within a Primary Market Area (PMA). A description of the PMAs for FRS may be found in 16.2.4 (Primary Market Areas). A listing of the wire centers designated for the provisioning of FRS is provided in the National Exchange Carriers Association, Inc. Tariff F.C.C. No. 4.

FRS requires the use of terminal equipment that functions as a multiplexer/bridge/router. The terminal equipment accumulates the customer data and puts it into a frame relay format suitable for transmission over the FRS network. This terminal equipment must be purchased separately from the FRS and must conform to American National Standards Institute (ANSI) and Committee Consultat de International Telegraphique et Telephonique (CCITT) standards.

16.2.2 Service Description

FRS is a transport service that facilitates the exchange of variable length information units (frames) between the customer's connections by way of assigned virtual connections. Each frame is passed to the Frame Relay Network with an address that specifies the virtual connection. Addresses are read by the network processor, and the frames are relayed to the preassigned destination.

Variable frame length capability is useful in communications between asynchronous LANs and for transport of synchronous data traffic. FRS is capable of handling the requirements of bursty data sources because of the ability of the service to allocate additional bandwidth when not in use by other sources.

CANCELLED

MAR 08 2000

By ST RS 3
Public Service Commission
MISSOURI

FILED

JUL 15 1994

Issued: MAY 24 1994

Effective: JUN 27 1994
Public Service Commission

By M. H. SCHULTEIS, Division Manager-Regulatory & Industry Relations
Southwestern Bell Telephone Company
St. Louis, Missouri

No Supplement to this tariff will be issued except for the purpose of canceling this tariff.

Access Services Tariff
Section 16
1st Revised Sheet 4
Replacing Original Sheet 4

ACCESS SERVICES

16. PACKET SERVICE-(Continued)

(RT)

(RT)

Issued: October 13, 1999

Effective: March 8, 2000

By JAN NEWTON, President-Missouri
Southwestern Bell Telephone Company
St. Louis, Missouri

CANCELLED
June 29, 2007
TO-2002-185
Missouri Public
Service Commission

FILED
Missouri Public
Service Commission

No supplement for this tariff will be issued except for the purpose of canceling this tariff.

Access Services Tariff
Section 16
Original Sheet 4

ACCESS SERVICES

RECEIVED

16. PACKET SERVICE--(Continued)

MAY 24 1994

16.2 Frame Relay Service (FRS)--(Continued)

MISSOURI
Public Service Commission

16.2.2 Service Description--(Continued)

The major components of the FRS are: 1) the Network Interface, which is the point of interconnection between the Telephone Company communications facilities and the customer terminal equipment; 2) the Access Link, which is the facility that provides access to the FRS Network via a connection from the customer's network interface; 3) the Multiplexed Services Connection, which is the ongoing connection from a Port to a Special Access Multiplexed Service multiplexer that provisions DS3-to-DS1 and DS1-to-DS0 arrangements; 4) the Port, which is the physical entry point for the Access Link or Multiplexed Services Connection into the FRS Network; 5) the Logical Link, which is the permanent virtual circuit that establishes the connection from one Access Link or Multiplexed Services Connection, and its associated Port, to another; 6) the Link Extension, which is the transmission facility between the customer's serving wire center and the nearest central office in the PMA; and 7) The Network Link, which is the ongoing connection between two PMAs within the same LATA.

The Access Link, Port, Logical Link, Link Extension and Network Link are available in three bandwidth speeds, 56 kbps, 384 kbps and 1.536 Mbps. The Multiplexed Services Connection is available for connection to 56 Kbps and 1.536 Mbps Ports only.

A detailed description of the rate elements applicable to FRS, how these rate elements are applied and nonrecurring charges are contained in 16.2.5 (Rate Regulations).

16.2.3 Service Provisioning

A. Manner of Provisioning

1. Provision of this service is subject to the availability and operational limitations of the equipment and associated facilities. FRS is provided to customers from the Telephone Company wire center locations specified in the National Exchange Carrier Association, Inc. Tariff F.C.C. No. 47-100-101.
2. FRS requires the use of customer provided equipment which must be compatible with the Telephone Company's equipment and facilities and must conform to industry standards and specifications as outlined in Southwestern Bell Telephone Company Frame Relay Interface Specifications and Service Features technical publication TP 76642.

CANCELLED

MAR 08 2000

By 151 RS 4
Public Service Commission
MISSOURI

FILED

MAY 15 1994

MISSOURI

Public Service Commission

Issued: MAY 24 1994

Effective: ~~SEP 15 1994~~

By M. H. SCHULTEIS, Division Manager-Regulatory & Industry Relations
Southwestern Bell Telephone Company
St. Louis, Missouri

No Supplement to this tariff will be issued except for the purpose of canceling this tariff.

Access Services Tariff
Section 16
1st Revised Sheet 5
Replacing Original Sheet 5

ACCESS SERVICES

16. PACKET SERVICE-(Continued)

(RT)

(RT)

Issued: October 13, 1999

Effective: March 8, 2000

By JAN NEWTON, President-Missouri
Southwestern Bell Telephone Company
St. Louis, Missouri

CANCELLED
June 29, 2007
TO-2002-185
Missouri Public
Service Commission

FILED
Missouri Public
Service Commission

No supplement for this tariff will be issued except for the purpose of canceling this tariff.

Access Services Tariff
Section 16
Original Sheet 5

RECEIVED

ACCESS SERVICES

MAY 24 1994

16. PACKET SERVICE--(Continued)

MISSOURI
Public Service Commission

16.2 Frame Relay Service (FRS)--(Continued)

16.2.3 Service Provisioning--(Continued)

A. Manner of Provisioning--(Continued)

It shall be the responsibility of the customer to ensure the continuing compatibility of the customer provided equipment that is used in conjunction with the FRS.

- 3. The Telephone Company will provision FRS up to and including the network interface. The network interface specifications are set forth in the Bellcore High Capacity Digital Service Channel Interface Specification Technical Reference TR-NPL-000055.

The placement of the network interface shall be located in a manner consistent with federal and state regulatory requirements. This location will be at each customer's premises, unless specified otherwise and agreed to by the Telephone Company.

- 4. When the customer requires the modification of standard service components not otherwise provided in this tariff, the modification may be furnished by the Telephone Company as specified in Section 12 (Specialized Service or Arrangements).
- 5. The Telephone Company undertakes the responsibility to maintain and repair the service which it furnishes. However, the customer, upon request, shall furnish such information as may be required to permit the Telephone Company to maintain the FRS and to assure that the service arrangement is in compliance with the regulations contained in this section. The customer shall be responsible for service maintenance, as specified in 13.3.1 (Miscellaneous Services), when no trouble is found in the Telephone Company facilities.

- 6. Network equipment installed by the Telephone Company on the customer's premises shall be and remain the property of the Telephone Company. The customer or user may not rearrange, disconnect, remove, attempt to repair, remote test or interface with any network equipment installed by the Telephone Company without prior written consent by the Telephone Company.

FILED

JUL 15 1994

MISSOURI
Public Service Commission

CANCELLED

MAR 08 2000
By 154 R55
Public Service Commission
MISSOURI

Issued: MAY 24 1994

Effective: ~~JUN 24 1994~~

By M. H. SCHULTEIS, Division Manager-Regulatory & Industry Relations
Southwestern Bell Telephone Company
St. Louis, Missouri

No Supplement to this tariff will be issued except for the purpose of canceling this tariff.

Access Services Tariff
Section 16
1st Revised Sheet 6
Replacing Original Sheet 6

ACCESS SERVICES

16. PACKET SERVICE-(Continued)

(RT)

(RT)

Issued: October 13, 1999

Effective: March 8, 2000

By JAN NEWTON, President-Missouri
Southwestern Bell Telephone Company
St. Louis, Missouri

CANCELLED
June 29, 2007
TO-2002-185
Missouri Public
Service Commission

FILED
Missouri Public
Service Commission

No supplement for this tariff will be issued except for the purpose of canceling this tariff.

Access Services Tariff
Section 16
Original Sheet 6

ACCESS SERVICES

RECEIVED

16. PACKET SERVICE-(Continued)

MAY 24 1994

16.2 Frame Relay Service (FRS)-(Continued)

MISSOURI
Public Service Commission

16.2.3 Service Provisioning-(Continued)

A. Manner of Provisioning-(Continued)

- 7. The customer shall be responsible for obtaining permission for the Telephone Company agents or employees to enter the premises of the customer at any reasonable hour for the purpose of installing, inspecting, repairing or, upon termination of the service, removing the service components of the Telephone Company.
- 8. Where FRS is used in connection with communications systems or equipment provided by a customer or user, the operating characteristics of such systems or equipment shall be such as not to interfere with the FRS offered by the Telephone Company. Such use is subject to the further provisions that the equipment, provided by the customer or user does not endanger the safety of the Telephone Company employees or the public; damage, harm, require change in or alteration of the equipment or other services of the Telephone Company; interfere with the proper operation of the Telephone Company equipment; or otherwise injure the public in its use of the Telephone Company services. Upon notice from the Telephone Company that the equipment provided by the customer or user is causing, or is likely to cause, such hazard or interference, the customer shall take such steps as shall be necessary to remove or prevent such hazard or interference.

B. Ordering Specifications and Provisions

- 1. The customer may access Frame Relay Service via a FRS Access Link. Where the FRS Access Link is not available the customer may utilize a MegaLink Data Service or High Capacity Service as specified in Section 7 (Special Access Service). When the customer utilizes a MegaLink Data Service or High Capacity Service to access the FRS network, the regulations, rates and charges as specified in Section 7 will apply in addition to the rates and charges associated with FRS.

When a customer utilizes a MegaLink Data Service or High Capacity Service in lieu of the FRS Access Link, the FRS Access Link nonrecurring charge or monthly rate will apply. However, all other rates and charges normally associated with the ordering, installing and provisioning of the FRS as specified in this Section will apply.

FILED

JUL 15 1994

MISSOURI
Public Service Commission

CANCELLED

MAR 08 2000

By *1st RSG*
Public Service Commission
MISSOURI

Issued: MAY 24 1994

Effective: ~~MAY 24 1994~~ 1994

By M. H. SCHULTEIS, Division Manager-Regulatory & Industry Relations
Southwestern Bell Telephone Company
St. Louis, Missouri

No Supplement to this tariff will be issued except for the purpose of canceling this tariff.

Access Services Tariff
Section 16
1st Revised Sheet 7
Replacing Original Sheet 7

ACCESS SERVICES

16. PACKET SERVICE-(Continued)

(RT)

(RT)

Issued: October 13, 1999

Effective: March 8, 2000

By JAN NEWTON, President-Missouri
Southwestern Bell Telephone Company
St. Louis, Missouri

CANCELLED
June 29, 2007
TO-2002-185
Missouri Public
Service Commission

FILED
Missouri Public
Service Commission

No supplement for this tariff will be issued except for the purpose of canceling this tariff.

Access Services Tariff
Section 16
Original Sheet 7

ACCESS SERVICES

RECEIVED

16. PACKET SERVICE-(Continued)

MAY 24 1994

16.2 Frame Relay Service (FRS)-(Continued)

16.2.3 Service Provisioning-(Continued)

MISSOURI
Public Service Commission

B. Ordering Specifications and Provisions-(Continued)

- 2. When a customer utilizes Special Access Service Multiplexed Services, the Multiplexed Services Connection is ordered in lieu of the Access Link. The nonrecurring charge or monthly rate for the Access Link will not apply; however, all other rates and charges normally associated with the ordering, installing and provisioning of the FRS, e.g., Ports and Logical Links, will be applicable.

The Multiplexed Services Connection is only available for connection to Special Access Multiplexed Services provided in wire centers located within a FRS Primary Market Area (PMA).

- 3. The Access Link or Multiplexed Services Connection must be associated with a Port.

The Access Link, Multiplexed Services Connection and the Port must all be ordered with the same bandwidth speed.

- 4. Service to a customer designated premises with a serving wire center located outside the PMA, but within the same LATA, is provisioned by the Link Extension.

The Link Extension will include distance sensitive charges based on the airline mileage using the V&H coordinates method, as set forth in the National Exchange Carrier Association, Inc. Tariff F.C.C. No. 4., from the customer's serving wire center to the nearest central office within the FRS PMA. For the 524 LATA, the customer serving wire center and the nearest central office inside the PMA must be both in the same state jurisdiction.

The Link Extension is not required were the serving wire center associated with the customer designated premises is located within the FRS PMA.

- 5. The Link Extension must be associated with an Access Link and must be ordered with the same bandwidth speed as the Access Link and the Port it supports.

FILED

JUL 15 1994

MISSOURI
Public Service Commission

CANCELLED

MAR 08 2000

157 RS 7

By
Public Service Commission
MISSOURI

Issued:

MAY 24 1994

Effective:

~~JUN 24 1994~~

No Supplement to this tariff will be issued except for the purpose of canceling this tariff.

Access Services Tariff
Section 16
1st Revised Sheet 8
Replacing Original Sheet 8

ACCESS SERVICES

16. PACKET SERVICE-(Continued)

(RT)

(RT)

Issued: October 13, 1999

Effective: March 8, 2000

By JAN NEWTON, President-Missouri
Southwestern Bell Telephone Company
St. Louis, Missouri

CANCELLED
June 29, 2007
TO-2002-185
Missouri Public
Service Commission

FILED
Missouri Public
Service Commission

No supplement for this tariff will be issued except for the purpose of canceling this tariff.

Access Services Tariff
Section 16
Original Sheet 8

ACCESS SERVICES

RECEIVED

16. PACKET SERVICE-(Continued)

MAY 24 1994

16.2 Frame Relay Service (FRS)-(Continued)

MISSOURI

16.2.3 Service Provisioning-(Continued)

Public Service Commission

B. Ordering Specifications and Provisions-(Continued)

- 6. The Logical Link must be associated with any two Access Links or Multiplexed Services Connections. The Logical Link must be ordered at a bit rate equal to the lower bit rate of the two associated Access Links or Multiplexed Services Connections.
- 7. The total bandwidth of all Logical Links associated with one FRS Port may exceed the bandwidth of that Port. This condition is referred to as oversubscription and when this occurs, there can be no guarantee that the bandwidth defined for that Logical Link will be available at any point in time.
- 8. A customer ordering an Access Link or Multiplexed Service Connection will be referred to as the Controller of the Access Link or Multiplexed Services Connection. When a customer subscribing to a Logical Link is not the Controller of both Access Links or Multiplexed Services Connections associated with it, the Telephone Company may require the permission of both Controllers in order to establish the Logical Link.

Access Links or Multiplexed Services Connections and Logical Links are ordered and billed independently and can have different customers as Controllers. A request by one customer to disconnect one component does not result in the disconnection of associated components. Only the Controller of an Access Link or a Multiplexed Services Connection may authorize a disconnect of that Access Link or Multiplexed Services Connection.

- 9. The Network Link must be associated with and ordered at the same time as the Logical Link.

The Network Link must be ordered at a bit rate equal to or greater than the lower bit rate of the Access Links or Multiplexed Services Connections it supports.

FILED

JUL 15 1994

MISSOURI
Public Service Commission

JUL 15 1994

Issued: MAY 24 1994

Effective: ~~JUN 24 1994~~

By M. H. SCHULTEIS, Division Manager-Regulatory & Industry Relations
Southwestern Bell Telephone Company
St. Louis, Missouri

CANCELLED

MAR 08 2000

By 151 R S 8
Public Service Commission
MISSOURI

No Supplement to this tariff will be issued except for the purpose of canceling this tariff.

Access Services Tariff
Section 16
1st Revised Sheet 9
Replacing Original Sheet 9

ACCESS SERVICES

16. PACKET SERVICE-(Continued)

(RT)

(RT)

Issued: October 13, 1999

Effective: March 8, 2000

By JAN NEWTON, President-Missouri
Southwestern Bell Telephone Company
St. Louis, Missouri

CANCELLED
June 29, 2007
TO-2002-185
Missouri Public
Service Commission

FILED
Missouri Public
Service Commission

No supplement for this tariff will be issued except for the purpose of canceling this tariff.

Access Services Tariff
Section 16
Original Sheet 9

ACCESS SERVICES

RECEIVED

16. PACKET SERVICE-(Continued)

MAY 24 1994

16.2 Frame Relay Service (FRS)-(Continued)

MISSOURI
Public Service Commission

16.2.3 Service Provisioning-(Continued)

B. Ordering Specifications and Provisions-(Continued)

- 10. Service furnished to one customer may be assumed by a new customer upon due notice of cancellation or abandonment, provided there is no lapse in service and the service is assumed exactly as provided to the previous customer. The new customer must assume all the obligations of the previous customer. Such transfers are subject to any applicable rates and charges as set forth in 16.2.5 (Rates Regulations).
- 11. FRS is ordered under the provisions specified in Section 5 (Ordering for Access Service). Also included in that section are charges associated with ordering FRS.

C. Limitations

- 1. The Telephone Company does not undertake to originate data, but offers the use of its service components, where facilities permit, to customers for the purpose of transporting customer originated data.
- 2. The responsibility of the Telephone Company shall be limited to furnishing network equipment suitable for FRS and to the maintenance and operation of such equipment in a manner proper for such service. Subject to this responsibility, the Telephone Company shall not be responsible for the through transmission of signals generated by the customer provided equipment or system, or for the quality of, or defects in, such transmission or the reception of signals by such equipment or systems.
- 3. The Telephone Company shall not be responsible for error correction. Error correction is the responsibility of the customer's Frame Relay compatible terminal equipment. FRS switches may discard frames with errors. They may also discard frames when the network supporting FRS is in a state of congestion. Congestion control and recovery mechanisms are as set forth in the Southwestern Bell Telephone Company Frame Relay Interface Specifications and Service Feature technical publication TP 76442.

CANCELLED

MAR 08 2000
By *ST RS 9*
Public Service Commission
MISSOURI

FILED

MISSOURI
Public Service Commission

Issued:

MAY 24 1994

Effective:

~~JUN 24 1994~~

JUL 15 1994

By M. H. SCHULTEIS, Division Manager-Regulatory & Industry Relations
Southwestern Bell Telephone Company
St. Louis, Missouri

No Supplement to this tariff will be issued except for the purpose of canceling this tariff.

Access Services Tariff
Section 16
1st Revised Sheet 10
Replacing Original Sheet 10

ACCESS SERVICES

16. PACKET SERVICE-(Continued)

(RT)

(RT)

Issued: October 13, 1999

Effective: March 8, 2000

By JAN NEWTON, President-Missouri
Southwestern Bell Telephone Company
St. Louis, Missouri

CANCELLED
June 29, 2007
TO-2002-185
Missouri Public
Service Commission

FILED
Missouri Public
Service Commission

No supplement for this tariff will be issued except for the purpose of canceling this tariff.

Access Services Tariff
Section 16
Original Sheet 10

ACCESS SERVICES

RECEIVED

16. PACKET SERVICE--(Continued)

MAY 24 1994

16.2 Frame Relay Service (FRS)--(Continued)

MISSOURI
Public Service Commission

16.2.3 Service Provisioning--(Continued)

C. Limitations--(Continued)

- 4. The Telephone Company shall not be responsible for installation, operation or maintenance of any terminal equipment, data unit or communications system provided by a customer or user. The Telephone Company is not responsible for adapting FRS to the technological requirements of any specific customer equipment.
- 5. The Telephone Company shall not be responsible to the customer or user if changes in any of the equipment, operations or procedures of the Telephone Company used in the provision of FRS render any facilities provided by the customer or user obsolete or require modification or alteration of such equipment or system or otherwise affect its use or performance, provided the Telephone Company has met any applicable information disclosure requirements otherwise required by law.

D. Allowance for Service Interruption

The Telephone Company will administer its network to insure the provision of an acceptable service levels to all users of the Telephone Company FRS. Service levels are considered acceptable when the service provides an average performance of at least 99.0 percent error free seconds up to the demarcation point (network interface) of the channel for operation at all transmission speeds offered by this tariff. When FRS is operating at an error performance level that is unsatisfactory to the customer, and the Telephone Company determines that the error performance level is below that specified above, the period of substandard performance will be considered as an interruption of service.

In the event of an interruption of service, the customer will be granted a credit allowance in conjunction with the regulations specified in 2.4.4 (Credit Allowance for Service Interruptions). Any credit allowance shall be based on the time of notice by the customer or user to the Telephone Company that an unsatisfactory performance level has occurred, provided that the customer promptly releases the services as requested by the Telephone Company to perform testing and maintenance. No credit allowance will be granted if the customer does not promptly release the services as requested by the Telephone Company to perform testing and maintenance.

CANCELLED

MAR 08 2000
By 151 RS 10
Public Service Commission
MISSOURI

FILED

JUL 13 1994

MISSOURI
Public Service Commission

Issued: MAY 24 1994

Effective: JUN 24 1994

No Supplement to this tariff will be issued except for the purpose of canceling this tariff.

Access Services Tariff
Section 16
1st Revised Sheet 11
Replacing Original Sheet 11

ACCESS SERVICES

16. PACKET SERVICE-(Continued)

(RT)

(RT)

Issued: October 13, 1999

Effective: March 8, 2000

By JAN NEWTON, President-Missouri
Southwestern Bell Telephone Company
St. Louis, Missouri

CANCELLED
June 29, 2007
TO-2002-185
Missouri Public
Service Commission

FILED
Missouri Public
Service Commission

No supplement for this tariff will be issued except for the purpose of canceling this tariff.

Access Services Tariff
Section 16
Original Sheet 11

ACCESS SERVICES

RECEIVED

16. PACKET SERVICE--(Continued)

MAY 24 1994

16.2 Frame Relay Service (FRS)--(Continued)

MISSOURI
Public Service Commission

16.2.3 Service Provisioning--(Continued)

D. Allowance for Service Interruption--(Continued)

will be made for interruption due to the negligence and/or failure of equipment provided by the customer or user. Furthermore, interruptions of service during any period in which the Telephone Company is not afforded access to the premises at which service is terminated will not receive a credit allowance.

When the Telephone Company FRS terminates at a central office multiplexer and trouble is found to be in the Telephone Company facilities associated with the Multiplex Services, a credit allowance for service interruptions to the Multiplexed Services will apply as specified in 2.4.4 (Credit Allowance for Service Interruptions).

16.2.4 Primary Market Areas

Frame Relay Service is provisioned within a Primary Market Area (PMA). A PMA is a specified area, within a LATA, established by the Telephone Company for the administration and provision of FRS. The specified areas consists of one or more wire centers suitably equipped for the provision of FRS capabilities. One or more PMAs can be located within a LATA.

A listing of the wire centers designated for the provisioning of FRS are provided in the National Exchange Carriers Association, Inc. Tariff F.C.C. No. 4.

16.2.5 Rate Regulations

This section contains the specific regulations governing the rates and charges which apply for Frame Relay Service (FRS).

There are two types of rates and charges that apply to the various rate elements for FRS. These are monthly recurring rates and nonrecurring charges.

Specific rates and charges are set forth in 16.4 (Rates and Charges). Jurisdictional reporting requirements are set forth in 2.3 (Certification of Special Access in Intrastate).

FILED

JUL 15 1994

MISSOURI
Public Service Commission

Issued: MAY 24 1994

Effective: JUN 24 1994

By M. H. SCHULTEIS, Division Manager-Regulatory & Industry Relations
Southwestern Bell Telephone Company
St. Louis, Missouri

CANCELLED

MAR 08 2000
By /st RS 11
Public Service Commission
MISSOURI

No Supplement to this tariff will be issued except for the purpose of canceling this tariff.

Access Services Tariff
Section 16
1st Revised Sheet 12
Replacing Original Sheet 12

ACCESS SERVICES

16. PACKET SERVICE-(Continued)

(RT)

(RT)

Issued: October 13, 1999

Effective: March 8, 2000

By JAN NEWTON, President-Missouri
Southwestern Bell Telephone Company
St. Louis, Missouri

CANCELLED
June 29, 2007
TO-2002-185
Missouri Public
Service Commission

FILED
Missouri Public
Service Commission

No supplement for this tariff will be issued except for the purpose of canceling this tariff.

Access Services Tariff
Section 16
Original Sheet 12

ACCESS SERVICES

- 16. PACKET SERVICE-(Continued)
- 16.2 Frame Relay Service (FRS)-(Continued)
- 16.2.5 Rate Regulations-(Continued)

RECEIVED

MAY 24 1994

MISSOURI
Public Service Commission

A. Rate Elements

The following are the various rate elements for FRS:

1. Access Link

The Access Link rate element provides the facilities from the customer's network interface to the FRS Network.

2. Multiplexed Services Connection

The Multiplexed Services Connection rate element provides for the ongoing interconnection from a Port to Special Access Multiplexed Services for DS3-to-DS1 and DS1-to-DS0 arrangements. The Multiplexed Services Connection rate element is applied in lieu of the Access Link.

3. Port

The Port rate element provides the physical entry point for the Access Link or Multiplexed Services Connection into the FRS Network.

4. Logical Link

The Logical Link rate element provides for the permanent virtual circuit, a logical channel, that establishes the two-way connection from one Access Link or Multiplexed Services Connection, and its associated Port, to another.

5. Link Extension

The Link Extension rate element provides for the transmission facilities between the serving wire center associated with the customer designated premises and the nearest central office within the PMA.

The Link Extension rate element is applied when the customer's serving wire center is located outside of an established PMA, but within the same LATA.

CANCELLED

MAR 08 2000
By 1st RS 12
Public Service Commission
MISSOURI

FILED

JUL 15 1994

MISSOURI
Public Service Commission

Issued: MAY 24 1994

Effective: JUN 24 1994

By M. H. SCHULTEIS, Division Manager-Regulatory & Industry Relations
Southwestern Bell Telephone Company
St. Louis, Missouri

No Supplement to this tariff will be issued except for the purpose of canceling this tariff.

Access Services Tariff
Section 16
1st Revised Sheet 13
Replacing Original Sheet 13

ACCESS SERVICES

16. PACKET SERVICE-(Continued)

(RT)

(RT)

Issued: October 13, 1999

Effective: March 8, 2000

By JAN NEWTON, President-Missouri
Southwestern Bell Telephone Company
St. Louis, Missouri

CANCELLED
June 29, 2007
TO-2002-185
Missouri Public
Service Commission

FILED
Missouri Public
Service Commission

No supplement for this tariff will be issued except for the purpose of canceling this tariff.

Access Services Tariff
Section 16
Original Sheet 13

ACCESS SERVICES

RECEIVED

16. PACKET SERVICE--(Continued)

MAY 24 1994

16.2 Frame Relay Service (FRS)--(Continued)

MISSOURI
Public Service Commission

16.2.5 Rate Regulations--(Continued)

6. Network Link

The Network Link rate element provides for the ongoing connection between two PMAs within the same LATA. The Network Link must be associated with a Logical Link.

B. Nonrecurring Charges

Nonrecurring charges are one-time charges that apply for a specific work activity. Nonrecurring charges are applicable for installation of the service, change to an existing service (e.g., each requested change in the transmission speed or for a new rate element at a new transmission speed) and service rearrangement.

In order to receive the benefits associated with ordering multiple Access Links or Multiplexed Services Connections, the following criteria must be met:

- Same Access Service Order
- Same Application for Service Date
- Same Due Date
- Same Billing Account Number (BAN)
- Same Customer Designated Premises

In order to receive the benefits associated with ordering multiple Logical Links, the following criteria must be met:

- Same Access Service Order
- Same Application for Service Date
- Same Due Date
- Same Billing Account Number (BAN)
- Same Controlling Access Links or Multiplexed Services Connection.

An Access Order Charge may be applicable as specified in 52 (Access Order).

FILED

JUL 15 1994

MISSOURI
Public Service Commission

CANCELLED

MAR 08 2000

By Public Service Commission
MISSOURI

Issued: MAY 24 1994

Effective: ~~MAY 24 1994~~

By M. H. SCHULTEIS, Division Manager-Regulatory & Industry Relations
Southwestern Bell Telephone Company
St. Louis, Missouri

No Supplement to this tariff will be issued except for the purpose of canceling this tariff.

Access Services Tariff
Section 16
1st Revised Sheet 14
Replacing Original Sheet 14

ACCESS SERVICES

16. PACKET SERVICE-(Continued)

(RT)

(RT)

Issued: October 13, 1999

Effective: March 8, 2000

By JAN NEWTON, President-Missouri
Southwestern Bell Telephone Company
St. Louis, Missouri

CANCELLED
June 29, 2007
TO-2002-185
Missouri Public
Service Commission

FILED
Missouri Public
Service Commission

No supplement for this tariff will be issued except for the purpose of canceling this tariff.

Access Services Tariff
Section 16
Original Sheet 14

ACCESS SERVICES

16. PACKET SERVICE-(Continued)

16.2 Frame Relay Service (FRS)-(Continued)

16.2.5 Rate Regulations-(Continued)

B. Nonrecurring Charges-(Continued)

1. Access Link

A nonrecurring charge applies for the installation of each Access Link. This charge is applied on a first and additional basis for each transmission speed ordered. If a customer orders multiple Access Links, the first Access Link is assessed the "first" charge. Each subsequent Access Link is assessed the "additional" charge.

A Port rate element must be applied with each Access Link.

2. Multiplexed Services Connection

A nonrecurring charge applies for the installation of each Multiplexed Services Connection between the central office based multiplexer and an associated Port. This charge is applied on a first and additional basis for each transmission speed ordered. If a customer orders multiple Multiplexed Services Connections, the first Multiplexed Services Connection is assessed the "first" charge. Each subsequent Multiplexed Services Connection is assessed the "additional" charge.

A Port rate element must be applied with each Multiplexed Services Connection.

3. Port

A nonrecurring charge applies for the installation of each Port that is associated with an Access Link or a Multiplexed Services Connection.

RECEIVED

MAY 24 1994

MISSOURI
Public Service Commission

CANCELLED

MAR 08 2000

By ISF RS 14
Public Service Commission
MISSOURI

FILED

JUL 15 1994

JUL MISSOURI

Issued:

MAY 24 1994

Effective:

~~JUN 2 1994~~ Public Service Commission

By M. H. SCHULTEIS, Division Manager-Regulatory & Industry Relations
Southwestern Bell Telephone Company
St. Louis, Missouri

No Supplement to this tariff will be issued except for the purpose of canceling this tariff.

Access Services Tariff
Section 16
1st Revised Sheet 15
Replacing Original Sheet 15

ACCESS SERVICES

16. PACKET SERVICE-(Continued)

(RT)

(RT)

Issued: October 13, 1999

Effective: March 8, 2000

By JAN NEWTON, President-Missouri
Southwestern Bell Telephone Company
St. Louis, Missouri

CANCELLED
June 29, 2007
TO-2002-185
Missouri Public
Service Commission

FILED
Missouri Public
Service Commission

No supplement for this tariff will be issued except for the purpose of canceling this tariff.

Access Services Tariff
Section 16
Original Sheet 15

ACCESS SERVICES

16. PACKET SERVICE--(Continued)

16.2 Frame Relay Service (FRS)--(Continued)

16.2.5 Rate Regulations--(Continued)

B. Nonrecurring Charges--(Continued)

4. Logical Link

A nonrecurring charge applies for the establishment of each Logical Link. This charge is applied on a first and additional basis for each transmission speed ordered. If a customer orders multiple Logical Links, the first Logical Link is assessed the "first" charge. Each subsequent Logical Link is assessed the "additional" charge.

5. Network Link

A nonrecurring charge applies for the installation of each Network Link connecting two PMAs within the same LATA.

6. Service Rearrangement

Service Rearrangements are changes to existing services which do not result in either (1) a change in the minimum period requirements, or (2) a change in the physical location of the point of termination at the customer's premises or the customer's end user's premises.

Changes which result in (1) the establishment of new minimum period obligations, or (2) the physical location of the point of termination are treated as a discontinuance of the existing service and an installation of a new service and all applicable nonrecurring charges will apply.

A change in the customer of record (i.e., existing FRS is provided and billed to a different entity) is considered a service rearrangement when the new customer assumes liability for all current and prior charges for the service(s) and has complied with the regulations and conditions specified in 2.2.1 (Assignment and Transfer of Facilities). An Access Order Charge will apply when a change of customer name or a change in billing data (name, address, contact name, or telephone number) is requested in conjunction with a change in the customer of record as described in 5.2.2 (Access Order Charge).

RECEIVED

MAY 24 1994

MISSOURI
Public Service Commission

CANCELLED

MAR 08 2000

By Public Service Commission
MISSOURI
15 RS 15

FILED

JUL 13 1994

MISSOURI
Public Service Commission

Issued: MAY 24 1994

Effective:

By M. H. SCHULTEIS, Division Manager-Regulatory & Industry Relations
Southwestern Bell Telephone Company
St. Louis, Missouri

No Supplement to this tariff will be issued except for the purpose of canceling this tariff.

Access Services Tariff
Section 16
1st Revised Sheet 16
Replacing Original Sheet 16

ACCESS SERVICES

16. PACKET SERVICE-(Continued)

(RT)

(RT)

Issued: October 13, 1999

Effective: March 8, 2000

By JAN NEWTON, President-Missouri
Southwestern Bell Telephone Company
St. Louis, Missouri

CANCELLED
June 29, 2007
TO-2002-185
Missouri Public
Service Commission

FILED
Missouri Public
Service Commission

No supplement for this tariff will be issued except for the purpose of canceling this tariff.

Access Services Tariff
Section 16
Original Sheet 16

ACCESS SERVICES

16. PACKET SERVICE-(Continued)

RECEIVED

16.2 Frame Relay Service (FRS)-(Continued)

MAY 24 1994

16.2.5 Rate Regulations-(Continued)

MISSOURI
Public Service Commission

B. Nonrecurring Charges-(Continued)

6. Service Rearrangement-(Continued)

Certain service rearrangements which are administrative in nature as specified in 7.3.1.B.3 (Nonrecurring Charges - Service Rearrangements) will be made without charge except as noted. Provisions for service rearrangements for which non-recurring charges will apply are also set forth in 7.3.1.B.3.

Nonrecurring charges specified in 7.4.12.2 (Miscellaneous Rates and Charges - Service Rearrangement Charge) will apply on a per link basis.

C. Monthly Rates

Monthly rates are fixed recurring rates that apply each month, or fraction thereof, that a specific rate element is provided. For billing purposes, each month is considered to have thirty (30) days.

Monthly recurring rates apply to the following rate elements.

1. Access Link

A monthly rate applies for each Access Link installed from the customer's network interface to a corresponding Port.

A Port rate element must also be applied with each Access Link.

2. Multiplexed Services Connection

A monthly rate applies for each Multiplexed Services Connection between the Telephone Company central office based multiplexer and an associated Port.

A Port rate element must also be applied with each Multiplexed Services Connection.

3. Port

A monthly rate applies for each Port that is associated with an Access Link or Multiplexed Services Connection.

FILED

JUL 15 1994

MISSOURI
Public Service Commission

JUL 15 1994

Issued: MAY 24 1994

Effective: ~~MAY 24 1994~~

By M. H. SCHULTEIS, Division Manager-Regulatory & Industry Relations
Southwestern Bell Telephone Company
St. Louis, Missouri

CANCELLED

MAR 08 2000

By
1st RSL
Public Service Commission
MISSOURI

No Supplement to this tariff will be issued except for the purpose of canceling this tariff.

Access Services Tariff
Section 16
1st Revised Sheet 17
Replacing Original Sheet 17

ACCESS SERVICES

16. PACKET SERVICE-(Continued)

(RT)

(RT)

Issued: October 13, 1999

Effective: March 8, 2000

By JAN NEWTON, President-Missouri
Southwestern Bell Telephone Company
St. Louis, Missouri

CANCELLED
June 29, 2007
TO-2002-185
Missouri Public
Service Commission

FILED
Missouri Public
Service Commission

No supplement for this tariff will be issued except for the purpose of canceling this tariff.

Access Services Tariff
Section 16
Original Sheet 17

ACCESS SERVICES

16. PACKET SERVICE--(Continued)

16.2 Frame Relay Service (FRS)--(Continued)

16.2.5 Rate Regulations--(Continued)

C. Monthly Rates--(Continued)

4. Logical Link

A monthly rate applies for each logical link that connects one Access Link or Multiplexed Services Connection, and its associated Port, to another.

5. Link Extension

There are two types of monthly rates that apply for the Link Extension. These are the fixed monthly rate and a monthly rate, per mile.

A fixed monthly rate applies for each Link Extension associated with an Access Link.

A monthly rate, per mile, applies to each airline mile between the serving wire center associated with the customer designated premises and the nearest central office within the PMA.

The Link Extension rates are in addition to the rates and charges associated with the Access Link.

6. Network Link

There are two types of monthly rates that apply for the Network Link. These are the fixed monthly rate and a monthly rate, per mile.

A fixed monthly rate applies for each Network Link connecting two PMAs within the same LATA.

A monthly rate per mile applies to each airline mile between the two closest central offices in the two PMAs that are connected.

The Network Link rates are in addition to the rates and charges associated with all other FRS rate elements.

RECEIVED

MAY 24 1994

MISSOURI
Public Service Commission

CANCELLED

MAR 08 2000
By ST R S 17
Public Service Commission
MISSOURI

FILED

JUL 15 1994

MISSOURI
Public Service Commission

Issued: MAY 24 1994

Effective: JUN 24 1994

By M. H. SCHULTEIS, Division Manager--Regulatory & Industry Relations
Southwestern Bell Telephone Company
St. Louis, Missouri

No Supplement to this tariff will be issued except for the purpose of canceling this tariff.

Access Services Tariff
Section 16
1st Revised Sheet 18
Replacing Original Sheet 18

ACCESS SERVICES

16. PACKET SERVICE-(Continued)

(RT)

(RT)

Issued: October 13, 1999

Effective: March 8, 2000

By JAN NEWTON, President-Missouri
Southwestern Bell Telephone Company
St. Louis, Missouri

CANCELLED
June 29, 2007
TO-2002-185
Missouri Public
Service Commission

FILED
Missouri Public
Service Commission

No supplement for this tariff will be issued except for the purpose of canceling this tariff.

Access Services Tariff
Section 16
Original Sheet 18

ACCESS SERVICES

16. PACKET SERVICE-(Continued)

16.2 Frame Relay Service (FRS)-(Continued)

16.2.5 Rate Regulations-(Continued)

D. Determining Mileage Measurements

The mileage to be used to determine the monthly rate, per mile, for the Link Extension and Network Link is calculated on the airline distance between the locations involved, i.e. the serving wire center associated with the customer designated premises and the nearest central office or the two central offices that are located in different PMAs. The serving wire center associated with a customer designated premises is the serving wire center from which the customer designated premises would normally obtain dial tone.

To determine the rate to be billed, first compute the mileage using the V&H coordinates method, as set forth in the National Exchange Carrier Association, Inc. Tariff F.C.C. No. 4, then apply the per mile rate as specified in 16.4.2 (Rates and Charges Frame Relay Service).

E. Minimum Period

Frame Relay Service is provided for a minimum period of one month. When service is disconnected prior to the expiration of the minimum period, monthly charges are applicable for the balance of the minimum period.

If service is disconnected after the minimum period, monthly charges will be based on the actual number of days the service is furnished. In order to determine the charges for a fractional portion of a month, every month is considered to have 30 days.

RECEIVED

MAY 24 1994

MISSOURI
Public Service Commission

CANCELLED

FILED

MAR 08 2000

JUL 15 1994

By *1st RS 18*
Public Service Commission
MISSOURI

MISSOURI
Public Service Commission

Issued: MAY 24 1994

Effective:

JUL 15 1994

~~JUN 24 1994~~

By M. H. SCHULTEIS, Division Manager-Regulatory & Industry Relations
Southwestern Bell Telephone Company
St. Louis, Missouri

No Supplement to this
tariff will be issued
except for the purpose
of canceling this tariff.

Access Services Tariff
Section 16
1st Revised Sheet 19
Replacing Original Sheet 19

ACCESS SERVICES

16. PACKET SERVICE-(Continued)

(RT)

Issued: October 13, 1999

Effective: March 8, 2000

By JAN NEWTON, President-Missouri
Southwestern Bell Telephone Company
St. Louis, Missouri

CANCELLED
June 29, 2007
TO-2002-185
Missouri Public
Service Commission

FILED
Missouri Public
Service Commission

No supplement for this tariff will be issued except for the purpose of canceling this tariff.

Access Services Tariff
Section 16
Original Sheet 19

ACCESS SERVICES

RECEIVED

16. PACKET SERVICE-(Continued)

MAY 24 1994

16.3 Reserved for Future Use

MISSOURI
Public Service Commission

CANCELLED

MAR 08 2000
By *158 R519*
Public Service Commission
MISSOURI

FILED

JUL 15 1994

MISSOURI
Public Service Commission

Issued: MAY 24 1994

Effective: ~~JUN 24 1994~~

By M. H. SCHULTEIS, Division Manager-Regulatory & Industry Relations
Southwestern Bell Telephone Company
St. Louis, Missouri

No Supplement to this tariff will be issued except for the purpose of canceling this tariff.

Access Services Tariff
Section 16
1st Revised Sheet 20
Replacing Original Sheet 20

ACCESS SERVICES

16. PACKET SERVICE-(Continued)

(RT)

(RT)

Issued: October 13, 1999

Effective: March 8, 2000

By JAN NEWTON, President-Missouri
Southwestern Bell Telephone Company
St. Louis, Missouri

CANCELLED
June 29, 2007
TO-2002-185
Missouri Public
Service Commission

FILED
Missouri Public
Service Commission

No supplement for this tariff will be issued except for the purpose of canceling this tariff.

Access Services Tariff
Section 16
Original Sheet 20

ACCESS SERVICES

16. PACKET SERVICE-(Continued)

16.4 Rates and Charges-(Continued)

16.4.1 Frame Relay Service

RECEIVED

MAY 24 1994

MISSOURI
Public Service Commission
Rate Per Month

A. Access Link

Per Access Link

56 Kbps (L7A5X) \$ 77.25
384 Kbps (L7A6X) \$165.00
1.536 Mbps (L7A7X) \$165.00

Nonrecurring Charge

56 Kbps, first \$365.00
56 Kbps, additional \$306.00

384 Kbps, first \$966.00
384 Kbps, additional \$838.00

1.536 Mbps, first \$966.00
1.536 Mbps, additional \$838.00

Rate Per Month

B. Multiplexed Services Connection

Per Connection

56 Kbps (MXQ5X) \$ 18.06
1.536 Mbps (MXQ7X) \$ 0.00

Nonrecurring Charge

56 Kbps, first \$107.00
56 Kbps, additional \$ 96.00

1.536 Mbps, first \$332.00
1.536 Mbps, additional \$280.00

FILED

JUL 15 1994

MISSOURI
Public Service Commission
JUL 15 1994

CANCELLED

MAR 08 2000
154 RS 20
By
Public Service Commission
MISSOURI

Issued: MAY 24 1994

Effective: JUN 9 1994

By M. H. SCHULTEIS, Division Manager-Regulatory & Industry Relations
Southwestern Bell Telephone Company
St. Louis, Missouri

No Supplement to this tariff will be issued except for the purpose of canceling this tariff.

Access Services Tariff
Section 16
1st Revised Sheet 21
Replacing Original Sheet 21

ACCESS SERVICES

16. PACKET SERVICE-(Continued)

(RT)

(RT)

Issued: October 13, 1999

Effective: March 8, 2000

By JAN NEWTON, President-Missouri
Southwestern Bell Telephone Company
St. Louis, Missouri

CANCELLED
June 29, 2007
TO-2002-185
Missouri Public
Service Commission

FILED
Missouri Public
Service Commission

No supplement for this tariff will be issued except for the purpose of canceling this tariff.

Access Services Tariff
Section 16
Original Sheet 21

ACCESS SERVICES

16. PACKET SERVICE-(Continued)

16.4 Rates and Charges-(Continued)

16.4.1 Frame Relay Service-(Continued)

RECEIVED

MAY 24 1994

MISSOURI
Public Service Commission

C. Port

Rate Per Month

Per Port

56 Kbps (P7E5X)	\$ 87.00
384 Kbps (P7E6X)	\$130.00
1.536 Mbps (P7E7X)	\$410.00

Nonrecurring Charge

56 Kbps	\$ 8.00
384 Kbps	\$ 46.00
1.536 Mbps	\$181.00

Rate Per Month

D. Logical Link

Per Logical Link

56 Kbps (L8G5X)	\$ 8.00
384 Kbps (L8G6X)	\$ 20.00
1.536 Mbps (L8G7X)	\$ 50.00

Nonrecurring Charge

56 Kbps, first	\$153.00
56 Kbps, additional	\$117.00
384 Kbps, first	\$163.00
384 Kbps, additional	\$127.00
1.536 Mbps, first	\$196.00
1.536 Mbps, additional	\$161.00

CANCELLED

MAR 08 2000

15 RS 21

Public Service Commission
MISSOURI

FILED

JUL 15 1994

MISSOURI
Public Service Commission

Issued: MAY 24 1994

Effective: JUL 15 1994

~~JUN 24 1994~~

By M. H. SCHULTEIS, Division Manager-Regulatory & Industry Relations
Southwestern Bell Telephone Company
St. Louis, Missouri

No Supplement to this tariff will be issued except for the purpose of canceling this tariff.

Access Services Tariff
Section 16
1st Revised Sheet 22
Replacing Original Sheet 22

ACCESS SERVICES

16. PACKET SERVICE-(Continued)

(RT)

(RT)

Issued: October 13, 1999

Effective: March 8, 2000

By JAN NEWTON, President-Missouri
Southwestern Bell Telephone Company
St. Louis, Missouri

CANCELLED
June 29, 2007
TO-2002-185
Missouri Public
Service Commission

FILED
Missouri Public
Service Commission

No supplement for this tariff will be issued except for the purpose of canceling this tariff.

Access Services Tariff
Section 16
Original Sheet 22

ACCESS SERVICES

RECEIVED

16. PACKET SERVICE--(Continued)

MAY 24 1994

16.4 Rates and Charges--(Continued)

MISSOURI
Public Service Commission

16.4.1 Frame Relay Service--(Continued)

Rate Per Month

E. Link Extension

Per Link Extension

Fixed

56 Kbps (1A5ES)	\$ 50.00
384 Kbps (1A5FS)	\$ 51.30
1.536 Mbps (1A5GS)	\$ 51.30

Per Mile

56 Kbps	\$ 0.75
384 Kbps	\$ 17.70
1.536 Mbps	\$ 17.70

F. Network Link

Per Network Link

Fixed

56 Kbps (1HWHS)	\$ 96.00
384 Kbps (1HWJS)	\$245.00
1.536 Mbps (1HWKS)	\$585.00

Per Mile

56 Kbps	\$ 0.75
384 Kbps	\$ 17.70
1.536 Mbps	\$ 17.70

Nonrecurring Charge

56 Kbps	\$ 16.00
384 Kbps	\$362.00
1.536 Mbps	\$362.00

FILED

JUL 15 1994

MISSOURI
Public Service Commission

JUL 15 1994

Issued: MAY 24 1994

Effective: ~~JUN 24 1994~~

By M. H. SCHULTEIS, Division Manager-Regulatory & Industry Relations
Southwestern Bell Telephone Company
St. Louis, Missouri

CANCELLED

MAR 08 2000

By 154 RS22
Public Service Commission
MISSOURI

No supplement for this tariff will be issued except for the purpose of canceling this tariff.

Access Services Tariff
Section 16
Original Sheet 22

ACCESS SERVICES

RECEIVED

16. PACKET SERVICE--(Continued)

MAY 24 1994

16.4 Rates and Charges--(Continued)

MISSOURI
Public Service Commission

16.4.1 Frame Relay Service--(Continued)

Rate Per Month

E. Link Extension

Per Link Extension

Fixed

56 Kbps (1A5ES)	\$ 50.00
384 Kbps (1A5FS)	\$ 51.30
1.536 Mbps (1A5GS)	\$ 51.30

Per Mile

56 Kbps	\$ 0.75
384 Kbps	\$ 17.70
1.536 Mbps	\$ 17.70

F. Network Link

Per Network Link

Fixed

56 Kbps (1HWHS)	\$ 96.00
384 Kbps (1HWJS)	\$245.00
1.536 Mbps (1HWKS)	\$585.00

Per Mile

56 Kbps	\$ 0.75
384 Kbps	\$ 17.70
1.536 Mbps	\$ 17.70

Nonrecurring Charge

56 Kbps	\$ 16.00
384 Kbps	\$362.00
1.536 Mbps	\$362.00

FILED

JUL 15 1994

MISSOURI
Public Service Commission

CANCELLED

MAR 08 2000

By 15# RS22
Public Service Commission
MISSOURI

~~JUL 15 1994~~

Issued: MAY 24 1994

Effective: ~~JUN 24 1994~~

By M. H. SCHULTEIS, Division Manager-Regulatory & Industry Relations
Southwestern Bell Telephone Company
St. Louis, Missouri

No Supplement to this tariff will be issued except for the purpose of canceling this tariff.

Access Services Tariff
Section 17
1st Revised Sheet 1
Replacing Original Sheet 1

ACCESS SERVICES

17. OPERATOR SERVICES

Operator Service is provided to customers from Telephone Company Operator Service System (OSS) locations.

17.1 Operator Call Processing

(CT) Operator Call Processing (OCP) includes the service categories of Operator Transfer and
(CT) Inward Assistance. Operator Transfer and Inward Assistance services are provided from OSS Tandems to the customer's premises in conjunction with the rules and regulations of the specified Access Services found in Sections 2, 3, 5 and 6, preceding. OCP is deployed at all Southwestern Bell Telephone Company (Telephone Company) end offices in a Local Access and Transport Area (LATA). The OSS Tandem locations are provided in Volume 4 of the Southwestern Bell Interexchange Customer Information Handbook.

(CT) 17.1.1 Operator Transfer Service Description

Operator Transfer is an originating service that provides call routing of calls requiring operator assistance to a participating customer as requested by the calling end user. An Operator Transfer call is routed to the Telephone Company's OSS when the calling party requires operator assistance for completion to a call outside the originating LATA.

If the calling end user requests the name of a specific customer, the Telephone Company operator will consult alphabetical reference information to verify service participation and transfer the call.

If the calling end user has no specific customer preference, the Telephone Company Operator will consult reference information to identify the presubscribed interexchange carrier serving the originating line and verify service participation. The calling end user will then be offered a transfer to the participating carrier presubscribed to the originating line. If the end user accepts, the operator will transfer the call. If the end user does not want to transfer to the presubscribed carrier, the operator will advise that the end user must state a preference in order to continue the call. If the end user continues to not have a preference, the operator will advise the end user to call back when the end user has determined the name of
(CT) a carrier to handle the call.

Issued: Mar. 5, 1999

Effective: Apr. 5, 1999

By PRISCILLA HILL-ARDOIN, President-Missouri
Southwestern Bell Telephone Company
St. Louis, Missouri

No supplement to this tariff will be issued except for the purpose of canceling this tariff.

Access Services Tariff
Section 17
Original Sheet 1

RECEIVED

ACCESS SERVICES

JUL 17 1990

(NR) 17. OPERATOR SERVICES

MISSOURI

Operator Service is provided to customers from Telephone Company Operator Service System (OSS) locations.

17.1 Operator Call Processing

Operator Call Processing (OCP) includes the service categories of 0- Transfer and Inward Assistance. 0- Transfer and Inward Assistance services are provided from OSS Tandems to the customer's premises in conjunction with the rules and regulations of the specified Access Services found in Sections 2, 3, 5 and 6, preceding. OCP is deployed at all Southwestern Bell Telephone Company (Telephone Company) end offices in a Local Access and Transport Area (LATA). The OSS Tandem locations are provided in Volume 4 of the Southwestern Bell Interexchange Customer Information Handbook.

17.1.1 0- Transfer Service Description

0- Transfer is an originating service that provides call routing of 0- (the digit "0" with no additional digits) calls to a participating customer as requested by the calling end user. A 0- Transfer call is routed to the Telephone Company's OSS operator for completion to a destination outside the originating LATA when the calling party dials "0" and waits for an operator to assist with the call. The Telephone Company operator will, upon request, transfer the call to the calling end user's participating customer of choice. If the calling end user has no specific customer preference, the OSS operator will consult reference information and offer to the calling party the name of a participating customer. The reference information is arranged to give all participating customers an equal opportunity of being offered to and chosen by the calling end user. After a selection is made by the calling end user, the operator will then key in the selected customer's Carrier Identification Code (CIC) and transfer the call.

CANCELLED

APR 05 1999

By *RS#1*
Public Service Commission
MISSOURI

Issued: JUL 17 1990

Effective: AUG 17 1990

FILED

By R. D. BARRON, President-Missouri Division
Southwestern Bell Telephone Company
St. Louis, Missouri

AUG 17 1990

Public Service Commission

No Supplement to this tariff will be issued except for the purpose of canceling this tariff.

Access Services Tariff
Section 17
1st Revised Sheet 2
Replacing Original Sheet 2

ACCESS SERVICES

17. OPERATOR SERVICES-(Continued)

17.1.2 Inward Assistance Service Description

Inward Assistance provides three operator service functions on inward calls received from participating customers. Inward Assistance is provided when a participating customer's operator contacts a Telephone

(C) Company OSS operator requesting line status verification with call interruption or dialing and/or routing assistance. Inward Assistance functions will be performed for only one telephone number per inward call received. The three Inward Assistance service functions available are detailed as follows:

- A. Busy Line Verification - The OSS operator will check the status of the requested telephone line to verify if there is conversation on the line and advise the requesting customer of the line status.
- B. Verification with Call Interruption - After verification of a conversation on the requested line is made, and upon request, the OSS operator will interrupt and inform the called party of the waiting call.
- C. Operator Assistance - The OSS operator will provide the customer with dialing or routing assistance such as identifying a city when given only a NPA-NXX or verifying that a specific number is a coin station. The OSS operator will provide a local emergency number and, if required, complete an emergency call to the local emergency agency number.

17.2 Manner of Provisioning

- (AT) A. Operator Call Processing trunking between the customer's premises and the OSS Tandem is provisioned as Switched Access FGC, FGD, BSA-C or
- (AT) BSA-D service and may be arranged, per the customer's request, as either one-way or two-way service. These trunk groups are established as final trunks and will be assigned data registers to obtain usage, peg count and overflow attempt information. If a trunk(s) does not currently exist between the customer's premises and
- (AT) the OSS Tandem(s), the customer must establish FGD or BSA-D service to the Telephone Company's OSS Tandem(s). The Telephone Company will provide trunk-side switching along with trunk-answer and disconnect supervisory signaling to the customer.

Issued: March 26, 1993 Effective: April 11, 1993

By R. D. BARRON, President-Missouri Division
Southwestern Bell Telephone Company
St. Louis, Missouri

No supplement to this tariff will be issued except for the purpose of canceling this tariff.

Access Services Tariff
Section 17

Original Sheet 2

RECEIVED

ACCESS SERVICES

JUL 17 1990

(NR) 17. OPERATOR SERVICES--(Continued)

MISSOURI

Public Service Commission

17.1.2 Inward Assistance Service Description

Inward Assistance provides three operator service functions on inward calls received from participating customers. Inward Assistance is provided when a participating customer's operator contacts a Telephone Company OSS operator requesting line status verification verification with call interruption or dialing and/or routing assistance. Inward Assistance functions will be performed for only one telephone number per inward call received. The three Inward Assistance service functions available are detailed as follows:

- A. Busy Line Verification - The OSS operator will check the status of the requested telephone line to verify if there is conversation on the line and advise the requesting customer of the line status.
- B. Verification with Call Interruption - After verification of a conversation on the requested line is made, and upon request, the OSS operator will interrupt and inform the called party of the waiting call.
- C. Operator Assistance - The OSS operator will provide the customer with dialing or routing assistance such as identifying a city when given only a NPA-NXX or verifying that a specific number is a coin station. The OSS operator will provide a local emergency number and, if required, complete an emergency call to the local emergency agency number.

17.2 Manner of Provisioning

- A. Operator Call Processing trunking between the customer's premises and the OSS Tandem is provisioned as either Switched Access Feature Group C or Feature Group D service and may be arranged, per the customer's request, as either one-way or two-way service. These trunk groups are established as final trunks and will be assigned data registers to obtain usage, peg count and overflow attempt information. If a trunk(s) does not currently exist between the customer's premises and the OSS Tandem(s), the customer must establish Feature Group D service to the Telephone Company's OSS Tandem(s). The Telephone Company will provide trunk-side switching along with trunk-answer and disconnect supervisory signaling to the customer.

CANCELLED

APR 11 1993

BY lat R.S. #1

Public Service Commission

MISSOURI

Issued: JUL 17 1990

Effective: AUG 17 1990

FILED

By R. D. BARRON, President-Missouri Division
Southwestern Bell Telephone Company
St. Louis, Missouri

AUG 17 1990

Public Service Commission

No Supplement to this tariff will be issued except for the purpose of canceling this tariff.

Access Services Tariff
Section 17
2nd Revised Sheet 3
Replacing 1st Revised Sheet 3

ACCESS SERVICES

17. OPERATOR SERVICES-(Continued)

17.2 Manner of Provisioning-(Continued)

(CT) B. When the OSS Tandem also functions as the Message Toll Service (MTS) Access Tandem, the customer may combine OCP traffic with its MTS Switched Access traffic between the OSS Tandem and the customer's premises provided the trunk group has the same signaling and routing requirements as specified for Operator Transfer or Inward Assistance. However, OCP traffic may not be combined with MTS Switched Access traffic if the customer provides operator functionality or coin station control.

(CT) 17.2.1 Operator Transfer

(FC) (AT) A. The customer must order or assign a separate trunk group and have a unique CIC for each name it uses for Operator Transfer Calls. The sharing of one customer's Switched Access trunk groups with one or more Switched Access customers is prohibited with Operator Transfer Service.
(AT)

(FC) B. The customer is required to handle requests from all end offices in the LATA. Accordingly, the customer must order sufficient capacity between the OSS Tandem(s) and the customer's premises to serve Operator Transfer traffic originating from those end offices. The Telephone Company OSS Tandems send 10-digit ANI (NPA + 7-digit telephone number) for FGD or BSA-D trunk groups with Equal Access Signaling or Operator Services Address Signaling and FGC or BSA-C trunk groups with Traditional Signaling. However, the Telephone Company OSS Tandems send 7-digit ANI for FGC or BSA-C trunk groups with Operator Services Signaling. Therefore, if the customer requires Operator Transfer calls separately identified by the originating NPA for the FGC or BSA-C trunk group with Operator Services Signaling, the customer must utilize a separate and final trunk group from the OSS Tandem to the customer's premises for each NPA served by that OSS Tandem.

(FC) C. In order for the customer to provide operator functionality (e.g., Operator Recall, Sequence Dialing, Time and Charge Quotation and Emergency Ring-Back) or coin station control, the customer must order Operator Trunk - Coin, Non-Coin, or Combined Coin and Non-Coin for FGC or BSA-C service or Operator Trunk - Full Feature for FGD or BSA-D service, as set forth in Section 6, Paragraph 6.3.2, preceding. In addition, when ordering coin station control, the customer must establish a separate and final trunk group for each type of end office operator/coin station signaling (i.e., inband, expanded inband, and multiwink) existing in the end offices served by the OSS Tandem.

(RT)
(RT)

Issued: Mar. 5, 1999

Effective: Apr. 5, 1999

By PRISCILLA HILL-ARDOIN, President-Missouri
Southwestern Bell Telephone Company
St. Louis, Missouri

No supplement to this tariff will be issued except for the purpose of canceling this tariff.

Access Services Tariff
Section 17
1st Revised Sheet 3
Replacing Original Sheet 3

RECEIVED

ACCESS SERVICES

MAR 29 1993

17. OPERATOR SERVICES--(Continued)

MISSOURI
Public Service Commission

17.2 Manner of Provisioning--(Continued)

B. When the OSS Tandem also functions as the Message Toll Service (MTS) Access Tandem, the customer may combine OCP traffic with its MTS Switched Access traffic between the OSS Tandem and the customer's premises provided the trunk group has the same signaling and routing requirements as specified for 0- Transfer or Inward Assistance. However, OCP traffic may not be combined with MTS Switched Access traffic if the customer provides operator functionality or coin station control.

17.2.1 0- Transfer

A. The customer is required to handle requests from all end offices in the LATA. Accordingly, the customer must order sufficient capacity between the OSS Tandem(s) and the customer's premises to serve 0- Transfer traffic originating from those end offices. The Telephone Company OSS Tandems send 10-digit ANI (NPA + 7-digit telephone number) for FGD or BSA-D trunk groups with Equal Access Signaling or Operator Services Address Signaling and FGC or BSA-C trunk groups with Traditional Signaling. However, the Telephone Company OSS Tandems send 7-digit ANI for FGC or BSA-C trunk groups with Operator Services Signaling. Therefore, if the customer requires 0- Transfer calls separately identified by the originating NPA for the FGC or BSA-C trunk group with Operator Services Signaling, the customer must utilize a separate and final trunk group from the OSS Tandem to the customer's premises for each NPA served by that OSS Tandem.

(AT)

(AT)

(AT)

(AT)

B. In order for the customer to provide operator functionality (e.g., Operator Recall, Sequence Dialing, Time and Charge Quotation and Emergency Ring-Back) or coin station control, the customer must order Operator Trunk - Coin, Non-Coin, or Combined Coin and Non-Coin for FGC or BSA-C service or Operator Trunk - Full Feature for FGD or BSA-D service, as set forth in Section 6, Paragraph 6.3.2, preceding. In addition, when ordering coin station control, the customer must establish a separate and final trunk group for each type of end office operator/coin station signaling (i.e., inband, expanded inband, and multiwink) existing in the end offices served by the OSS Tandem. 0- Transfer is not available for coin sent-paid traffic.

(AT)

(AT)

CANCELLED

FILED

APR 05 1999
By 2nd RS #3
Public Service Commission
MISSOURI

APR 11 1993
92-304

Issued:

Effective:

MO. PUBLIC SERVICE COM. APR 11 1993

MAR 26 1993

By R. D. BARRON, President-Missouri Division
Southwestern Bell Telephone Company
St. Louis, Missouri

No supplement to this tariff will be issued except for the purpose of canceling this tariff.

Access Services Tariff
Section 17
Original Sheet 3

RECEIVED

JUL 17 1990

ACCESS SERVICES

(NR) 17. OPERATOR SERVICES-(Continued)

MISSOURI
Public Service Commission

17.2 Manner of Provisioning-(Continued)

B. When the OSS Tandem also functions as the Message Toll Service (MTS) Access Tandem, the customer may combine OCP traffic with its MTS Switched Access traffic between the OSS Tandem and the customer's premises provided the trunk group has the same signaling and routing requirements as specified for O- Transfer or Inward Assistance. However, OCP traffic may not be combined with MTS Switched Access traffic if the customer provides operator functionality or coin station control.

17.2.1 O- Transfer

- A. The customer is required to handle requests from all end offices in the LATA. Accordingly, the customer must order sufficient capacity between the OSS Tandem(s) and the customer's premises to serve O- Transfer traffic originating from those end offices. The Telephone Company OSS Tandems send 10-digit ANI (NPA + 7-digit telephone number) for Feature Group D trunk groups with Equal Access Signaling or Operator Services Address Signaling and Feature Group C trunk groups with Traditional Signaling. However, the Telephone Company OSS Tandems send 7-digit ANI for Feature Group C trunk groups with Operator Services Signaling. Therefore, if the customer requires O- Transfer calls separately identified by the originating NPA for the Feature Group C trunk group with Operator Services Signaling, the customer must utilize a separate and final trunk group from the OSS Tandem to the customer's premises for each NPA served by that OSS Tandem.
- B. In order for the customer to provide operator functionality (e.g., Operator Recall, Sequence Dialing, Time and Charge Quotation and Emergency Ring-Back) or coin station control, the customer must order Operator Trunk - Coin, Non-Coin, or Combined Coin and Non-Coin for Feature Group C service or Operator Trunk - Full Feature for Feature Group D service, as set forth in Section 6, Paragraph 6.3.2, preceding. In addition, when ordering coin station control, the customer must establish a separate and final trunk group for each type of end office operator/coin station signaling (i.e., inband, expanded inband, and multiwink) existing in the end offices served by the OSS Tandem. O- Transfer is not available for coin sent-paid traffic.

CANCELLED
APR 11 1993

BY J. R. S. #3
Public Service Commission
MISSOURI

Issued: JUL 17 1990

Effective: AUG 17 1990

FILED

By R. D. BARRON, President-Missouri Division
Southwestern Bell Telephone Company
St. Louis, Missouri

AUG 17 1990

Public Service Commission

No Supplement to this tariff will be issued except for the purpose of canceling this tariff.

Access Services Tariff
Section 17
2nd Revised Sheet 4
Replacing 1st Revised Sheet 4

ACCESS SERVICES

17. OPERATOR SERVICES-(Continued)

17.2 Manner of Provisioning-(Continued)

17.2.2 Signaling

- (CT)
- A. For Operator Transfer, the Telephone Company will provide Traditional Signaling for FGC or BSA-C service or Equal Access Signaling for FGD or BSA-D service. Customers providing operator functionality for operator traffic or coin station control for coin station traffic will be provided with Operator Services Signaling for FGC or BSA-C or Operator Services Address Signaling for FGD or BSA-D service.
 - B. For Inward Assistance, the Telephone Company will provide Traditional Signaling for FGC or BSA-C service or Equal Access Signaling for FGD or BSA-D service.
 - C. Signaling specifications for OCP Service are set forth in Technical Reference TR-TSY-*000271.

17.2.3 Design Layout Report

Upon request, the Telephone Company will provide to the customer the make-up of facilities and services provided from the customer's premises to the OSS Tandem. This information will be provided in the form of a Design Layout Report. The Design Layout Report will be provided at no charge and will be reissued or updated whenever the facilities provided for the customer's use are materially changed.

17.2.4 Design Blocking

Trunks between the customer's premises and the OSS Tandems will follow the normal FGC, FGD, BSA-C or BSA-D blocking criteria as set forth in Section 6, Paragraph 6.8.7, preceding. The Telephone Company will perform routine measurement functions to inform the customer that an adequate number of transmission paths are in service to meet the normal FGC, FGD, BSA-C or BSA-D design blocking levels.

17.2.5 Acceptance Testing

Acceptance testing for OCP will be provided as set forth in Section 6, Paragraph 6.1.4, preceding. Testing capabilities for FGC, FGD, BSA-C or BSA-D services utilized in conjunction with OCP will be provided as set forth in Section 6, Paragraph 6.2.3, D. and 6.2.4, D., preceding.

Issued: Mar. 5, 1999

Effective: Apr. 5, 1999

By PRISCILLA HILL-ARDOIN, President-Missouri
Southwestern Bell Telephone Company
St. Louis, Missouri

No supplement to this tariff will be issued except for the purpose of canceling this tariff.

Access Services Tariff
Section 17
1st Revised Sheet 4
Replacing Original Sheet 4

ACCESS SERVICES

RECEIVED

17. OPERATOR SERVICES--(Continued)

MAR 29 1993

17.2 Manner of Provisioning--(Continued)

MISSOURI
Public Service Commission

17.2.2 Signaling

(AT)
(AT)
(AT)
(AT)

A. For O- Transfer, the Telephone Company will provide Traditional Signaling for FGC or BSA-C service or Equal Access Signaling for FGD or BSA-D service. Customers providing operator functionality for operator traffic or coin station control for coin station traffic will be provided with Operator Services Signaling for FGC or BSA-C or Operator Services Address Signaling for FGD or BSA-D service.

(AT)
(AT)

B. For Inward Assistance, the Telephone Company will provide Traditional Signaling for FGC or BSA-C service or Equal Access Signaling for FGD or BSA-D service.

CANCELLED

C. Signaling specifications for OCP Service are set forth in Technical Reference TR-TSY-*000271.

APR 05 1993

17.2.3 Design Layout Report

By 2nd RS #4
Public Service Commission
MISSOURI

Upon request, the Telephone Company will provide to the customer the make-up of facilities and services provided from the customer's premises to the OSS Tandem. This information will be provided in the form of a Design Layout Report. The Design Layout Report will be provided at no charge and will be reissued or updated whenever the facilities provided for the customer's use are materially changed.

17.2.4 Design Blocking

(AT)
(FC)
(AT)

Trunks between the customer's premises and the OSS Tandems will follow the normal FGC, FGD, BSA-C or BSA-D blocking criteria as set forth in Section 6, Paragraph 6.8.7, preceding. The Telephone Company will perform routine measurement functions to inform the customer that an adequate number of transmission paths are in service to meet the normal FGC, FGD, BSA-C or BSA-D design blocking levels.

17.2.5 Acceptance Testing

(AT)

Acceptance testing for OCP will be provided as set forth in Section 6, Paragraph 6.1.4, preceding. Testing capabilities for FGC, FGD, BSA-C or BSA-D services utilized in conjunction with OCP will be provided as set forth in Section 6, Paragraph 6.2.3, D. and 6.2.4, D., preceding.

Issued: MAR 26 1993

Effective:

By R. D. BARRON, President-Missouri Division
Southwestern Bell Telephone Company
St. Louis, Missouri

APR 11 1993
FILED

APR 11 1993
92 - 304
MO. PUBLIC SERVICE COMM.

No supplement to this tariff will be issued except for the purpose of canceling this tariff.

Access Services Tariff
Section 17
Original Sheet 4

ACCESS SERVICES

RECEIVED

(NR) 17. OPERATOR SERVICES-(Continued)

JUL 17 1990

17.2 Manner of Provisioning-(Continued)

MISSOURI

17.2.2 Signaling

Public Service Commission

- A. For O- Transfer, the Telephone Company will provide Traditional Signaling for Feature Group C service or Equal Access Signaling for Feature Group D service. Customers providing operator functionality for operator traffic or coin station control for coin station traffic will be provided with Operator Services Signaling for Feature Group C or Operator Services Address Signaling for Feature Group D service.
- B. For Inward Assistance, the Telephone Company will provide Traditional Signaling for Feature Group C service or Equal Access Signaling for Feature Group D service.
- C. Signaling specifications for OCP Service are set forth in Technical Reference TR-TSY-*000271.

CANCELLED

APR 11 1993

by let R.S. #4

17.2.3 Design Layout Report

Upon request, the Telephone Company will provide to the customer's premises make-up of facilities and services provided from the customer's premises to the OSS Tandem. This information will be provided in the form of a Design Layout Report. The Design Layout Report will be provided at no charge and will be reissued or updated whenever the facilities provided for the customer's use are materially changed.

Public Service Commission
MISSOURI

17.2.4 Design Blocking

Trunks between the customer's premises and the OSS Tandems will follow the normal Feature Group C or D blocking criteria as set forth in Section 6, Paragraph 6.5.7, preceding. The Telephone Company will perform routine measurement functions to inform the customer that an adequate number of transmission paths are in service to meet the normal Feature Group C or D design blocking levels.

17.2.5 Acceptance Testing

Acceptance testing for OCP will be provided as set forth in Section 6, Paragraph 6.1.4, preceding. Testing capabilities for Feature Group C and Feature Group D services utilized in conjunction with OCP will be provided as set forth in Section 6, Paragraph 6.2.3, D. and 6.2.4, D., preceding.

Issued:

JUL 17 1990

Effective: AUG 17 1990

FILED

By R. D. BARRON, President-Missouri Division
Southwestern Bell Telephone Company
St. Louis, Missouri

AUG 17 1990

Public Service Commission

No Supplement to this tariff will be issued except for the purpose of canceling this tariff.

ACCESS SERVICES

(NR) 17. OPERATOR SERVICES-(Continued)

17.2 Manner of Provisioning-(Continued)

17.2.6 Interface and Transmission Parameters

Operator Call Processing will utilize the same interface groups and transmission specifications as specified in Section 6, Paragraphs 6.2.3, C. and 6.2.4, C., preceding.

17.2.7 Ordering Options and Conditions

Operator Call Processing is ordered under the Access Order provisions as set forth in Section 5, preceding. The Access Order Charge applicable for Switched Access will apply per Access Order for the installation, addition, change or rearrangement of OCP service. In addition, other Access Order Charges (i.e., Service Date Change Charges, Cancellation Charges, etc.) may apply.

17.3 Liability of the Telephone Company

In addition to the liability statements as set forth in Section 2, preceding, the following also applies.

- A. The Telephone Company's liability, if any, for its gross negligence or willful misconduct is not limited by this Tariff. With respect to any other claim or suit, by a customer or any others, for damages arising out of negligent mistakes, omissions, interruptions, delays or errors, defects in transmission, omission from or defects in the applicable list of customers or transfers to customers occurring in the course of furnishing service hereunder, the Telephone Company's liability, if any, shall not exceed an amount equivalent to the proportionate charge to the customer for the period of time during which such mistake, omission, interruptions, delays, errors, defects in transmission or service, omission from or defects in the applicable list of customers or transfers to customers continues. However, any such mistakes, omissions, interruptions, delays, errors, or defects in transmission or service, omission from or defects in the applicable list of customers or transfers to customers which are caused by or contributed to by the negligent omission or willful act of the customer-provided facilities or equipment shall not result in the imposition of any liability whatsoever upon the Telephone Company.

Issued: July 17, 1990

Effective: August 17, 1990

By R. D. BARRON, President-Missouri Division
Southwestern Bell Telephone Company
St. Louis, Missouri

No Supplement to this tariff will be issued except for the purpose of canceling this tariff.

ACCESS SERVICES

(NR) 17. OPERATOR SERVICES-(Continued)

17.3 Liability of the Telephone Company-(Continued)

A. (Continued)

The Telephone Company expressly disclaims any express or implied warranty for the aforesaid service or offering including no warranty of merchantability or warranty of fitness for any particular purpose. It is expressly acknowledged by all subscribers to the aforesaid service that errors, mistakes and omissions can and will occur and that the Telephone Company neither warrants nor guarantees faultless or perfect service or transmission.

B. The customer indemnifies and saves the Telephone Company harmless against claims for libel, slander or infringement of copyright and trademark arising from the information transmitted over facilities furnished hereunder and against all other claims arising out of any act or omission of the customer in connection with facilities provided by the Telephone Company.

C. The customer indemnifies and saves the Telephone Company harmless against claims or suits for damages arising where the connection between the calling end user and a local emergency agency is in some way faulty or impaired, due in whole or in part to the negligent mistake or delay of the Telephone Company. Examples of this may include, but are not limited to, instances in which the Telephone Company, through negligent mistake or delay, may provide an incorrect local emergency agency number, delay in locating a local emergency agency number or disconnect an in-progress call between a calling end user and a local emergency agency.

17.4 Obligations of the Customer

In addition to the general regulations as set forth in Section 2, preceding, the following also applies.

A. The customer shall provide the necessary on-hook, off-hook, answer supervision and disconnect supervision at the customer's premises.

B. Jurisdictional reporting will apply as required in Section 2, Paragraph 2.3.13, for determining the Percent Interstate Usage (PIU).

Issued: July 17, 1990

Effective: August 17, 1990

By R. D. BARRON, President-Missouri Division
Southwestern Bell Telephone Company
St. Louis, Missouri

No Supplement to this tariff will be issued except for the purpose of canceling this tariff.

Access Services Tariff
Section 17
2nd Revised Sheet 7
Replacing 1st Revised Sheet 7

ACCESS SERVICES

17. OPERATOR SERVICES-(Continued)

17.5 Rate Regulation

17.5.1 Description and Application of Rates and Charges

(CT) A. Operator Transfer

(CT) The Operator Transfer charge is a flat-rate charge applicable per call transferred.

(CT) In addition to the Operator Transfer charge, recurring Switched Access premium rates apply as set forth in Section 6, Paragraph 6.11, preceding, for usage originating from all end offices served by the OSS Tandem. Carrier Common Line (CCL) charges as set forth in Section 3, Paragraph 3.8, preceding, also will apply for originating

(CT) Operator Transfer usage.

Nonrecurring Switched Access charges are applicable as specified in Section 6, Paragraphs 6.10 and 6.11, preceding.

B. Inward Assistance

The Inward Assistance flat-rate charges are specific to the operator function performed and are applied per attempt. In addition to including all operator work time and equipment necessary to perform the requested operator function, these charges also include the recurring traffic-sensitive usage costs associated with premium Switched Access Service. The specific charges for Inward Assistance are shown below:

- (1) Busy Line Verification - applicable per busy line verify attempt.
- (2) Call Interrupt with Verification - applicable per busy line verify/call interrupt attempt.
- (3) Operator Assistance - applicable per Operator Assistance attempt.

Recurring Switched Access rates including CCL charges are not applicable for Inward Assistance. Nonrecurring Switched Access charges are applicable as specified in Section 6, Paragraphs 6.10 and 6.11, preceding.

Issued: Mar. 5, 1999

Effective: Apr. 5, 1999

By PRISCILLA HILL-ARDOIN, President-Missouri
Southwestern Bell Telephone Company
St. Louis, Missouri

No supplement to this tariff will be issued except for the purpose of canceling this tariff.

Access Services Tariff
Section 17
1st Revised Sheet 7
Replacing Original Sheet 7

ACCESS SERVICES

17. OPERATOR SERVICES--(Continued)

17.5 Rate Regulation

17.5.1 Description and Application of Rates and Charges

A. 0- Transfer

RECEIVED

MAR 29 1993

MISSOURI
Public Service Commission

The 0- Transfer charge is a flat-rate charge applicable per call transferred.

(FC)

In addition to the 0- Transfer charge, recurring Switched Access premium rates apply as set forth in Section 6, Paragraph 6.11, preceding, for usage originating from all end offices served by the OSS Tandem. Carrier Common Line (CCL) charges as set forth in Section 3, Paragraph 3.8, preceding, also will apply for originating 0- Transfer usage.

(FC)

Nonrecurring Switched Access charges are applicable as specified in Section 6, Paragraphs 6.10 and 6.11, preceding.

B. Inward Assistance

The Inward Assistance flat-rate charges are specific to the operator function performed and are applied per attempt. In addition to including all operator work time and equipment necessary to perform the requested operator function, these charges also include the recurring traffic-sensitive usage costs associated with premium Switched Access Service. The specific charges for Inward Assistance are shown below:

- (1) Busy Line Verification - applicable per busy line verify attempt.
- (2) Call Interrupt with Verification - applicable per busy line verify/call interrupt attempt.
- (3) Operator Assistance - applicable per Operator Assistance attempt.

(FC)

(FC)

Recurring Switched Access rates including CCL charges are not applicable for Inward Assistance. Nonrecurring Switched Access charges are applicable as specified in Section 6, Paragraphs 6.10 and 6.11, preceding.

FILED

APR 11 1993

92 - 304

MO. PUBLIC SERVICE COM. APR 11 1993

Issued: MAR 26 1993

Effective:

By R. D. BARRON, President-Missouri Division
Southwestern Bell Telephone Company
St. Louis, Missouri

CANCELLED
APR 05 1999
By 2nd RS # 7
Public Service Commission
MISSOURI

No supplement to this tariff will be issued except for the purpose of canceling this tariff.

Access Services Tariff
Section 17
Original Sheet 7

ACCESS SERVICES

RECEIVED

(NR) 17. OPERATOR SERVICES--(Continued)

JUL 17 1990

17.5 Rate Regulation

MISSOURI

17.5.1 Description and Application of Rates and Charges

Public Service Commission

A. 0- Transfer

The 0- Transfer charge is a flat-rate charge applicable per call transferred.

In addition to the 0- Transfer charge, recurring Switched Access premium rates apply as set forth in Section 6, Paragraph 6.8, preceding for usage originating from all end offices served by the OSS Tandem. Carrier Common Line (CCL) charges asset forth in Section 3, Paragraph 3.8, preceding, also will apply for originating 0- Transfer usage.

Nonrecurring Switched Access charges are applicable as specified in Section 6, Paragraphs 6.7 and 6.8, preceding.

B. Inward Assistance

The Inward Assistance flat-rate charges are specified to the operator function performed and are applied per attempt. In addition to including all operator work time and equipment necessary to perform the requested operator function, these charges also include the recurring traffic-sensitive usage costs associated with premium Switched Access Service. The specific charges for Inward Assistance are shown below:

- (1) Busy Line Verification - applicable per busy line verify attempt.
- (2) Call Interrupt with Verification - applicable per busy line verify/call interrupt attempt.
- (3) Operator Assistance - applicable per Operator Assistance attempt.

Recurring Switched Access rates including CCL charges are not applicable for Inward Assistance. Nonrecurring Switched Access charges are applicable as specified in Section 6, Paragraphs 6.7 and 6.8, preceding.

CANCELLED

APR 11 1993

BY let R.S. #1

Public Service Commission
MISSOURI

Issued: JUL 17 1990

Effective: AUG 17 1990

By R. D. BARRON, President-Missouri Division
Southwestern Bell Telephone Company
St. Louis, Missouri

FILED

AUG 17 1990

Public Service Commission

No Supplement to this tariff will be issued except for the purpose of canceling this tariff.

Access Services Tariff
Section 17
1st Revised Sheet 8
Replacing Original Sheet 8

ACCESS SERVICES

17. OPERATOR SERVICES-(Continued)

17.5 Rate Regulation-(Continued)

17.5.2 Rates and Charges

		<u>USOC</u>	<u>Recurring Rate</u>
(CT)	(A) Operator Transfer per call transferred(1)	ZZUOP	\$0.30
	(B) Inward Assistance Per Attempt		
	(1) Busy Line Verification	ZZUBV	\$0.75
	(2) Verification with Call Interrupt	ZZUBN	\$1.50
	(3) Operator Assistance	ZZUOH	\$0.22

(1) In addition, Switched Access charges are applicable as detailed in Section 17, Paragraph 17.5.1, preceding.

Issued: Mar. 5, 1999

Effective: Apr. 5, 1999

By PRISCILLA HILL-ARDOIN, President-Missouri
Southwestern Bell Telephone Company
St. Louis, Missouri

No supplement to this tariff will be issued except for the purpose of canceling this tariff.

Access Services Tariff
Section 17
Original Sheet 8

ACCESS SERVICES

RECEIVED

JUL 17 1990

MISSOURI
Public Service Commission

(NR) 17. OPERATOR SERVICES-(Continued)

17.5 Rate Regulation-(Continued)

17.5.2 Rates and Charges

	<u>USOC</u>	<u>Recurring Rate</u>
(A) 0- Transfer per call transferred(1)	ZZUOP	\$0.30
(B) Inward Assistance Per Attempt		
(1) Busy Line Verification	ZZUBV	\$0.75
(2) Verification with Call Interrupt	ZZUBN	\$1.50
(3) Operator Assistance	ZZUOH	\$0.22

CANCELLED

APR 05 1999
By *ls 25 #8*
Public Service Commission
MISSOURI

(1) In addition, Switched Access charges are applicable as detailed in Section 17, Paragraph 17.5.1, preceding.

Issued: JUL 17 1990

Effective: AUG 17 1990

By R. D. BARRON, President-Missouri Division
Southwestern Bell Telephone Company
St. Louis, Missouri

FILED

AUG 17 1990

Public Service Commission

No Supplement to this tariff will be issued except for the purpose of canceling this tariff.

Access Services Tariff
Section 18
2nd Revised Sheet 1
Replacing 1st Revised Sheet 1

ACCESS SERVICES

18. DIRECTLINE-CUSTOMsm

The Telephone Company will provide DirectLine-Custom service to ICs and end users from the DirectLine-Custom database location.

18.1 General Description

The Telephone Company will provision DirectLine-Custom to allow direct on-line electronic access to the Telephone Company's directory database without a directory assistance operator being involved.

(AT) The DirectLine-Custom database is accessed through the Telephone Company's
| MicroLink II packet network utilizing the X.25 protocol or through a direct dial-up
| access utilizing either a Microsoft\ Windows~*
(AT) based software package or the customer's communication software.

The database provided will include listing details when a name search is initiated. The detail for both residential and business published listings includes the name, address, and telephone number.

The capability to make additions, deletions, modifications, or to enhance the listing information within the DirectLine-Custom database will not be provided.

The DirectLine-Custom database compilation is and shall remain the sole property of Southwestern Bell Telephone Company. Nothing in this tariff nor in the offering of this service shall grant a license or other property interest in use of this database.

18.2 Undertaking of the Telephone Company

A. The Telephone Company will provide a directory database that will be updated daily.

(AT) B. When access to the DirectLine-Custom database is via the Telephone
(AT) Company's MicroLink II\ Service, the MICROLINK II\ packet network software will be provided to make the X.25 logical connections to the host computer.

C. The host computer software will provide the capability to obtain detailed listing information when a name search is initiated.

sm Service Mark of Southwestern Bell Telephone Company

®Registered Service Mark of Southwestern Bell Telephone Company

(AT) *Microsoft is a registered trademark and Windows is a trademark of Microsoft
(AT) Corporation.

Issued: January 13, 1995

Effective: February 13, 1995

By HORACE WILKINS, JR., President-Missouri
Southwestern Bell Telephone Company
St. Louis, Missouri

No supplement to this tariff will be issued except for the purpose of canceling this tariff.

Access Services Tariff
Section 18
1st Revised Sheet
Replacing Original Sheet 1

RECEIVED

JUN 26 1991

ACCESS SERVICES

MISSOURI
Public Service Commission

18. DIRECTLINE-CUSTOMSM

(CP)

The Telephone Company will provide DirectLine-CustomSM service to ICs and end users from the DirectLine-Custom database location.

18.1 General Description

The Telephone Company will provision DirectLine-Custom to allow direct on-line electronic access to the Telephone Company's directory database without a directory assistance operator being involved.

The database provided will include listing details when a name search is initiated. The detail for both residential and business published listings includes the name, address, and telephone number.

The capability to make additions, deletions, modifications, or to enhance the listing information within the DirectLine-Custom database will not be provided.

The DirectLine-Custom database compilation is and shall remain the sole property of Southwestern Bell Telephone Company. Nothing in this tariff nor in the offering of this service shall grant a license or other property interest in use of this database.

18.2 Undertaking of the Telephone Company

- A. The Telephone Company will provide a directory database that will be updated daily.
- B. The MICROLINK II[®] packet network software will be provided to make the X.25 logical connections to the host computer.
- C. The host computer software will provide the capability to obtain detailed listing information when a name search is initiated.

CANCELLED

FEB 13 1995
BY *[Signature]*
Public Service Commission
MISSOURI

FILED

JUL 29 1991

SM Service Mark of Southwestern Bell Telephone Company
[®] Registered Service Mark of Southwestern Bell Telephone Company

Public Service Commission

Issued:

JUN 27 1991

Effective:

JUL 29 1991

By R. D. BARRON, President-Missouri Division
Southwestern Bell Telephone Company
St. Louis, Missouri

No supplement to this tariff will be issued except for the purpose of canceling this tariff.

Access Services Tariff
Section 18
Original Sheet 1

RECEIVED

ACCESS SERVICES

JUL 6 1990

MISSOURI

Public Service Commission

(NR) 18. DIRECTLINE-CUSTOMSM

The Telephone Company will provide DirectLine-Custom service to a customer from the DirectLine-Custom host computer database location.

18.1 General Description

The Telephone Company will provision DirectLine-Custom to allow direct on-line electronic access to the Telephone Company's directory database without a directory assistance operator being involved.

The database provided will include listing details when a name search is initiated. The detail for both residential and business published listings includes the name, address, and telephone number.

The capability to make additions, deletions, modifications, or to enhance the listing information within the DirectLine-Custom database will not be provided.

The DirectLine-Custom database compilation is and shall remain the sole property of Southwestern Bell Telephone Company. Nothing in this tariff nor in the offering of this service shall grant a license or other property interest in use of this database.

18.2 Undertaking of the Telephone Company

- A. The Telephone Company will provide a directory database that will be updated daily.
- B. The MICROLINK II[®] packet network software will be provided to make the X.25 logical connections to the host computer.
- C. The host computer software will provide the capability to obtain detailed listing information when a name search is initiated.

CANCELLED

FILED

JUL 29 1991

AUG 17 1990

BY 1st RS #1

Public Service Commission

SM Service Mark of Southwestern Bell Telephone Company
^R Registered Service Mark of Southwestern Bell Telephone Company
MISSOURI

Issued: JUL 17 1990

Effective: AUG 17 1990

By R. D. BARRON, President-Missouri Division
Southwestern Bell Telephone Company
St. Louis, Missouri

No supplement to this tariff will be issued except for the purpose of canceling this tariff.

Access Services Tariff
Section 18
1st Revised Sheet 2
Replacing Original Sheet 2

RECEIVED

MAR 6 1991

ACCESS SERVICES

18. DIRECTLINE-CUSTOM-(Continued)

18.2 Undertaking of the Telephone Company-(Continued)

MISSOURI
Public Service Commission

(RT)

- D. The Telephone Company will provide the customer with access to all Numbering Plan Areas (NPAs) within the Telephone Company's territory.
- E. The Telephone Company's host computer will validate the user ID to determine which NPAs are authorized for access.
- F. Telephone numbers which are not listed in the Directory Assistance operator's records will not be available.
- G. DirectLine-Custom host computer access will be provisioned through the Telephone Company's MICROLINK II packet network with an X.25 protocol.
- H. A circuit connection will be established between the DirectLine-Custom database and the Telephone Company MICROLINK II packet network.
- I. The Telephone Company will provide the circuit connection termination hardware at the Telephone Company's MICROLINK II packet network and at the DirectLine-Custom host computer.
- J. The Telephone Company will provide a host computer that consists of a communication interface processor, central processor unit, and mass storage units.
- K. The DirectLine-Custom host computer software will collect billing data which can be compiled into two reports; a summary report of all DirectLine-Custom activity that occurred during a specified period, and a full detailed report for each user ID activity during the same period.
- L. The Telephone Company will provide the following DirectLine-Custom user support functions to ensure host database integrity and coordinate customer billing:
 1. Establish initial user ID on the host computer and change the user ID at the customer's request.
 2. Add/Remove users through individual account maintenance records.

CANCELLED

FEB 15 1995

FILED

APR 8 1991

BY 2nd R.S. # 2
Public Service Commission
MISSOURI

Public Service Commission

Issued: MAR 0 8 1991

Effective: APR 0 8 1991

By R. D. BARRON, President-Missouri Division
Southwestern Bell Telephone Company
St. Louis, Missouri

No supplement to this tariff will be issued except for the purpose of canceling this tariff.

Access Services Tariff
Section 18
Original Sheet 2

RECEIVED

ACCESS SERVICES

JUL 6 1990

(NR) 18. DIRECTLINE-CUSTOM-(Continued)

MISSOURI
Public Service Commission

18.2 Undertaking of the Telephone Company-(Continued)

- D. The Telephone Company will provide the customer with access to all Numbering Plan Areas (NPAs) within the Telephone Company's territory except for home NPAs for users with Identification Numbers (IDs) that correspond to that home NPA.
- E. The Telephone Company's host computer will validate the user ID to determine which NPAs are authorized for access.
- F. Telephone numbers which are not listed in the Directory Assistance operator's records will not be available.
- G. DirectLine-Custom host computer access will be provisioned through the Telephone Company's MICROLINK II packet network with an X.25 protocol.
- H. A circuit connection will be established between the DirectLine-Custom database and the Telephone Company MICROLINK II packet network.
- I. The Telephone Company will provide the circuit connection termination hardware at the Telephone Company's MICROLINK II packet network and at the DirectLine-Custom host computer.
- J. The Telephone Company will provide a host computer that consists of a communication interface processor, central processor unit, and mass storage units.
- K. The DirectLine-Custom host computer software will collect billing data which can be compiled into two reports; a summary report of all DirectLine-Custom activity that occurred during a specified period, and a full detailed report for each user ID activity during the same period.
- L. The Telephone Company will provide the following DirectLine-Custom user support functions to ensure host database integrity and coordinate customer billing:
 - 1. Establish initial user ID on the host computer and change the user ID at the customer's request.
 - 2. Add/Remove users through individual account maintenance records.

CANCELLED

APR 8 1991

FILED

Issued: JUL 17 1990

BY phr s #2

Effective: AUG 17 1990

Public Service Commission
By R. D. BARRON, President
Southwestern Bell Telephone Company
St. Louis, Missouri
Public Service Commission

No Supplement to this tariff will be issued except for the purpose of canceling this tariff.

Access Services Tariff
Section 18
2nd Revised Sheet 3
Replacing 1st Revised Sheet 3

ACCESS SERVICES

18. DIRECTLINE-CUSTOMsm-(Continued)

18.2 Undertaking of the Telephone Company-(Continued)

(FC) I. (Continued)

3. Maintain files on the host computer system, including modification of ID and passwords as necessary.
4. Perform daily backup of customer accounting files, and backup (i.e. daily, weekly) of the entire disc system.
5. Deliver user names and passwords to the DirectLine-Custom customer.

(FC) J. The Telephone Company will provide the MICROLINK II packet network to establish the link between the customer's network and the DirectLine-Custom host computer.

18.3 Obligations of the Customer

In addition to the regulations as set forth in Paragraph 18.2, preceding, the customer has certain specific obligations pertaining to the use of DirectLine-Custom service. These obligations are as follows:

- (AT) A. When the customer chooses access to the DirectLine-Custom database
(AT) through the Telephone Company's MicroLink II packet network, the customer
(CT) must order MICROLINK II service as set forth in Section 16, preceding, of this tariff.
- (CT) B. The customer's equipment must be compatible with the Telephone Company's serving arrangement and utilize X.25 capability when accessing the DirectLine-Custom database through the MICROLINK II packet network.
- (AT) C. The use of a standard packet network numbering plan name is required when
(AT) the customer utilizes the Telephone Company's MicroLink II Service.
- (AT) D. A user ID and a password will be required to make the final connection to the DirectLine-Custom database at the DirectLine-Custom host computer when the customer utilizes the Telephone Company's MicroLink II Service.
- E. The customer shall provide to the Telephone Company a DirectLine-Custom Percent Interstate Usage (PIU) Report in accordance with the provisions specified in Paragraph 18.4 of this tariff.

Issued: January 13, 1995

Effective: February 13, 1995

By HORACE WILKINS, JR., President-Missouri
Southwestern Bell Telephone Company
St. Louis, Missouri

No supplement to this tariff will be issued except for the purpose of canceling this tariff.

Access Services Tariff
Section 18
1st Revised Sheet 3
Replacing Original Sheet 3

ACCESS SERVICES

RECEIVED

18. DIRECTLINE-CUSTOM-(Continued)

MAR 6 1991

18.2 Undertaking of the Telephone Company-(Continued)

MISSOURI

L. (Continued)

Public Service Commission

- 3. Maintain files on the host computer system, including modification of ID and passwords as necessary.
- 4. Perform daily backup of customer accounting files, and backup (i.e. daily, weekly) of the entire disc system.
- 5. Deliver user names and passwords to the DirectLine-Custom customer.

M. The Telephone Company will provide the MICROLINK II packet network to establish the link between the customer's network and the DirectLine-Custom host computer.

18.3 Obligations of the Customer

In addition to the regulations as set forth in Paragraph 18.2, preceding, the customer has certain specific obligations pertaining to the use of DirectLine-Custom service. These obligations are as follows:

- A. The customer will order MICROLINK II service as set forth in Section 16, preceding, of this tariff.
- B. The customer's equipment must be compatible with the Telephone Company's serving arrangement and utilize X.25 capability to access the DirectLine-Custom database through the MICROLINK II packet network.
- C. The use of a standard packet network numbering plan name is required.
- D. A user ID and a password will be required to make the final connection to the DirectLine-Custom database at the DirectLine-Custom host computer.
- E. The customer shall provide to the Telephone Company a DirectLine-Custom Percent Interstate Usage (PIU) Report in accordance with the provisions specified in Paragraph 18.4 of this tariff.

CANCELLED
FEB 13 1995
BY 2nd RS #3
Public Service Commission
MISSOURI

FILED

APR 8 1991

Public Service Commission

Issued: MAR 0 8 1991

Effective: APR 0 8 1991

By R. D. BARRON, President-Missouri Division
Southwestern Bell Telephone Company
St. Louis, Missouri

(CT)
|
(CT)

No supplement to this tariff will be issued except for the purpose of canceling this tariff.

Access Services Tariff
Section 18
Original Sheet 3

ACCESS SERVICES

RECEIVED

JUL 6 1990

(NR) 18. DIRECTLINE-CUSTOM-(Continued)

18.2 Undertaking of the Telephone Company-(Continued)

MISSOURI
Public Service Commission

L. (Continued)

- 3. Maintain files on the host computer system, including modification of ID and passwords as necessary.
 - 4. Perform daily backup of customer accounting files, and backup (i.e. daily, weekly) of the entire disc system.
 - 5. Deliver user names and passwords to the DirectLine-Custom customer.
- M. The Telephone Company will provide the MICROLINK II packet network to establish the link between the customer's network and the DirectLine-Custom host computer.

18.3 Obligations of the Customer

In addition to the regulations as set forth in Paragraph 18.2, preceding, the customer has certain specific obligations pertaining to the use of DirectLine-Custom service. These obligations are as follows:

- A. The customer will order MICROLINK II service as set forth in Section 16, preceding, of this tariff.
- B. The customer's equipment must be compatible with the Telephone Company's serving arrangement and utilize X.25 capability to access the DirectLine-Custom database through the MICROLINK II packet network.
- C. The use of a standard packet network numbering plan name is required.
- D. A user ID and a password will be required to make the final connection to the DirectLine-Custom database at the DirectLine-Custom host computer.
- E. The customer shall provide Jurisdictional Reports as specified in Paragraph 18.4 of this tariff.

CANCELLED

FILED

APR 8 1991

AUG 17 1990

BY PHRS #3

Public Service Commission

Public Service Commission
MISSOURI

Issued: JUL 17 1990

Effective: AUG 17 1990

By R. D. BARRON, President-Missouri Division
Southwestern Bell Telephone Company
St. Louis, Missouri

No Supplement to this tariff will be issued except for the purpose of canceling this tariff.

Access Services Tariff
Section 18
2nd Revised Sheet 4
Replacing 1st Revised Sheet 4

ACCESS SERVICES

18. DIRECTLINE-CUSTOM-(Continued)

18.4 Jurisdictional Report Requirements

(FC) When a customer orders DirectLine-Custom service or Directory Assistance service, the customer shall, when it places the order, provide the projected interstate percentage for terminating use in a whole number (a number of 0 through 100) for DirectLine-Custom service or for each Directory Access Service group ordered. (A method the customer may wish to adopt could be to use its terminating traffic from its premises to the involved Directory Assistance location and calculate the projected interstate percentage as set forth in Section 2, Paragraph 2.3.13). The Telephone Company will designate the number obtained by subtracting the projected interstate percentage furnished by the customer from 100 (100 - customer percentage = intrastate percentage) as the projected intrastate percentage of use.

In determining the interstate percentage of use, the customer should consider a DirectLine-Custom query for an NPA listing that is from the same NPA as the originator, home NPA, or a foreign NPA listing within the originator's state, as an intrastate query.

18.5 Optional Features

The customer has the option of receiving formatted or unformatted data.

A. Formatted Data

Data transmitted to the customer from the host computer which includes screen formatting characters which control the display of host computer prompt and response information.

B. Unformatted Data

Data transmitted to the customer from the host computer which does not include screen-formatting characters. The customer provides the software interface program to format the host computer information received by the customer.

Issued: March 26, 1993

Effective: April 11, 1993

By R.D. BARRON, President-Missouri Division
Southwestern Bell Telephone Company
St. Louis, Missouri

No supplement to this tariff will be issued except for the purpose of canceling this tariff.

Access Services Tariff
Section 18
1st Revised Sheet 4
Replacing Original Sheet 4

RECEIVED

MAR 6 1991

ACCESS SERVICES

18. DIRECTLINE-CUSTOM-(Continued)

18.4 Jurisdictional Report Requirements

MISSOURI
Public Service Commission

When a customer orders DirectLine-Custom service or Directory Assistance service the customer shall, when it places the order, provide the projected interstate percentage for terminating use in a whole number (a number of 0 through 100) for DirectLine-Custom service or for each Directory Access Service group ordered. (A method the customer may wish to adopt could be to use its terminating traffic from its premises to the involved Directory Assistance location and calculate the projected interstate percentage as set forth in Section 2, Paragraph 2.3.13, A.) The Telephone Company will designate the number obtained by subtracting the projected interstate percentage furnished by the customer from 100 (100 - customer percentage - intrastate percentage) as the projected intrastate percentage of use.

(AT)
|
(AT)

In determining the interstate percentage of use, the customer should consider a DirectLine-Custom query for a NPA listing that is from the same NPA as the originator, home NPA, or a foreign NPA listing within the originator's state, as an intrastate query.

18.5 Optional Features

The customer has the option of receiving formatted or unformatted data.

A. Formatted Data

Data transmitted to the customer from the host computer from the host computer which includes screen formatting characters which control the display of host computer prompt and response information.

B. Unformatted Data

Data transmitted to the customer from the host computer which does not include screen-formatting characters. The customer provides the software interface program to format the host computer information received by the customer.

CANCELLED
APR 11 1991
BY 2nd R.S. #4
Public Service Commission
MISSOURI

FILED

APR 8 1991

Public Service Commission

Issued: MAR 0 8 1991

Effective: APR 0 8 1991

By R. D. BARRON, President-Missouri Division
Southwestern Bell Telephone Company
St. Louis, Missouri

No supplement to this tariff will be issued except for the purpose of canceling this tariff.

Access Services Tariff
Section 18
Original Sheet 4

RECEIVED

ACCESS SERVICES

JUL 6 1990

(NR) 18. DIRECTLINE-CUSTOM-(Continued)

18.4 Jurisdictional Report Requirements

MISSOURI
Public Service Commission

When a customer orders DirectLine-Custom service or Directory Assistance service the customer shall, when it places the order, provide the projected interstate percentage for terminating use in a whole number (a number of 0 through 100) for DirectLine-Custom service or for each Directory Access Service group ordered. (A method the customer may wish to adopt could be to use its terminating traffic from its premises to the involved Directory Assistance location and calculate the projected interstate percentage as set forth in Section 2, Paragraph 2.3.13, A.) The Telephone Company will designate the number obtained by subtracting the projected interstate percentage furnished by the customer from 100 (100 - customer percentage = intrastate percentage) as the projected intrastate percentage of use.

18.5 Optional Features

The customer has the option of receiving formatted or unformatted data.

A. Formatted Data

Data transmitted to the customer from the host computer which includes screen formatting characters which control the display of host computer prompt and response information.

B. Unformatted Data

Data transmitted to the customer from the host computer which does not include screen-formatting characters. The customer provides the software interface program to format the host computer information received by the customer.

CANCELLED

APR 8 1991
BY RS.#4
Public Service Commission
MISSOURI

FILED

AUG 17 1990

Public Service Commission

Issued: JUL 17 1990

Effective: AUG 17 1990

By R. D. BARRON, President-Missouri Division
Southwestern Bell Telephone Company
St. Louis, Missouri

No Supplement to this tariff will be issued except for the purpose of canceling this tariff.

Access Services Tariff
Section 18
1st Revised Sheet 5
Replacing Original Sheet 5

ACCESS SERVICES

18. DIRECTLINE-CUSTOMsm-(Continued)

18.6 Minimum Period

(RT)(CP)
| |
| |
(RT)(CP)

DirectLine-Custom Service is provided for a minimum period of one month. When service is disconnected prior to or after the minimum period, the applicable charges will be the total of the actual usage charges incurred.

18.7 Credit Allowance for Service Interruptions

Credit allowance application provisions as specified in Section 2, Paragraph 2.4.4, B. and C., preceding, will also apply for DirectLine-Custom.

Issued: January 13, 1995

Effective: February 13, 1995

By HORACE WILKINS, JR., President-Missouri
Southwestern Bell Telephone Company
St. Louis, Missouri

No supplement to this tariff will be issued except for the purpose of canceling this tariff.

Access Services Tariff
Section 18
Original Sheet 5

RECEIVED

JUL 6 1990

ACCESS SERVICES

(NR) 18. DIRECTLINE-CUSTOM (Continued)

MISSOURI
Public Service Commission

18.6 Minimum Period

The minimum period for which DirectLine-Custom is provided and for which charges apply is six months. A minimum period of six months applies for each additional period of service ordered or extended.

If DirectLine-Custom service is discontinued prior to the end of each six month period, the charges that apply for the remaining months are the nonrecoverable costs. Such costs include the nonrecoverable cost of equipment and material ordered, provided or used, plus the nonrecoverable cost of installation and removal including the cost of engineering, labor, supervision, transportation, rights-of-way, and other associated costs less estimated net salvage.

18.7 Credit Allowance for Service Interruptions

Credit allowance application provisions as specified in Section 2, Paragraph 2.4.4, B. and C., preceding, will also apply for DirectLine-Custom.

CANCELLED

FEB 18 1995
BY let P.S. #5
Public Service Commission
MISSOURI

FILED

AUG 17 1990

Public Service Commission

Issued: JUL 17 1990

Effective: AUG 17 1990

By R. D. BARRON, President-Missouri Division
Southwestern Bell Telephone Company
St. Louis, Missouri

No Supplement to this tariff will be issued except for the purpose of canceling this tariff.

Access Services Tariff
Section 18
1st Revised Sheet 6
Replacing Original Sheet 6

ACCESS SERVICES

18. DIRECTLINE-CUSTOMsm-(Continued)

18.8 Rate Regulations

(RT) This section contains the specific regulations governing the rates and charges that apply for DirectLine-Custom.

(FC)(RT) In addition, when the customer utilizes the Telephone Company's MicroLink II packet network, the recurring and nonrecurring rates and charges for
(RT) MICROLINK II as set forth in Section 16, preceding, will apply.

(FC) A. DirectLine-Custom Rates and Charges

There are two types of rates and charges for DirectLine-Custom that will apply. These are recurring and nonrecurring charges.

1. Nonrecurring

These are one time charges specifically applicable to DirectLine-Custom:

The Service Establishment Charge, Initial Subsequent User ID Charge, and Subsequent User ID Charge.

Issued: January 13, 1995

Effective: February 13, 1995

By HORACE WILKINS, JR., President-Missouri
Southwestern Bell Telephone Company
St. Louis, Missouri

No supplement to this tariff will be issued except for the purpose

Access Services Tariff
Section 18
Original Sheet 6

ACCESS SERVICES

RECEIVED

JUL 6 1990

(NR) 18. DIRECTLINE-CUSTOM (Continued)

MISSOURI
Public Service Commission

18.8 Rate Regulations

This section contains the specific regulations governing the rates and charges that apply for DirectLine-Custom. The two types of rates and charges that apply to this service are MICROLINK II and DirectLine-Custom specific.

A. MICROLINK II Rates and Charges

The recurring and nonrecurring rates and charges for MICROLINK II as set forth in Section 16, preceding, will apply for the provision of DirectLine-Custom.

B. DirectLine-Custom Rates and Charges

There are two types of rates and charges for DirectLine-Custom that will apply. These are recurring and nonrecurring charges.

1. Nonrecurring

These are one time charges specifically applicable to DirectLine-Custom:

The Service Establishment Charge, Initial Subsequent User ID Charge, and Subsequent User ID Charge.

CANCELLED

FEB 13 1995
BY *1st R.S. #6*
Public Service Commission
MISSOURI

FILED

AUG 17 1990

Public Service Commission

Issued: JUL 17 1990

Effective: AUG 17 1990

R. D. BARRON, President-Missouri Division
Southwestern Bell Telephone Company
St. Louis, Missouri

No Supplement to this tariff will be issued except for the purpose of canceling this tariff.

ACCESS SERVICES

(NR) 18. DIRECTLINE-CUSTOM (Continued)

18.8 Rate Regulations (Continued)

B. DirectLine-Custom Rates and Charges (Continued)

1. Nonrecurring (Continued)

A. Service Establishment Charge

This charge applies per request for the service. The rate element includes the activities associated with establishing the circuits to the database. This element also includes the establishment of the initial User ID. If the customer requires multiple User IDs with the establishment of service, an "additional" User ID charge applies to each additional User ID.

B. User ID Charge

A User ID charge is applicable on a first and additional User ID basis. If a customer orders multiple User IDs on a single request, the first User ID is assessed the "first" User ID charge (except at the time service is initially established, as specified in A., preceding) and each additional User ID is assessed the "additional" User ID charge.

Issued: July 17, 1990

Effective: August 17, 1990

By HORACE WILKINS, JR., President-Missouri
Southwestern Bell Telephone Company
St. Louis, Missouri

No Supplement to this tariff will be issued except for the purpose of canceling this tariff.

ACCESS SERVICES

(NR) 18. DIRECTLINE-CUSTOM (Continued)

18.8 Rate Regulations (Continued)

1. Nonrecurring (Continued)

The following are examples of the Service Establishment Charge and the User ID Charge applications.

Example 1:

If a customer requires only one User ID at the time service is established, the following charges apply:

- One Service Establishment Charge (includes initial User ID)

Example 2:

If a customer requires two User IDs at the time service is established, the following charges apply:

- One Service Establishment Charge (includes initial User ID)
- One "Additional" User ID Charge

Example 3:

If a customer requires three User IDs at the time service is established, the following charges apply:

- One Service Establishment Charge (includes initial User ID)
- Two "Additional" User ID Charges

If the same customer requires three additional User IDs after his service is established, the following charges apply:

- One "First" User ID Charge
- Two "Additional" User ID Charges

Issued: July 17, 1990

Effective: August 17, 1990

By HORACE WILKINS, JR., President-Missouri
Southwestern Bell Telephone Company
St. Louis, Missouri

No Supplement to this tariff will be issued except for the purpose of canceling this tariff.

Access Services Tariff
Section 18
1st Revised Sheet 9
Replacing Original Sheet 9

ACCESS SERVICES

18. DIRECTLINE-CUSTOMsm-(Continued)

18.8 Rate Regulations (Continued)

2. Recurring

This charge applies specifically to the DirectLine-Custom service.

A. Screen Charge

This charge is applied per screen requested by the customer. A screen contains 1 to 11 detail listing records; i.e. name, address (when available), and telephone number or major business/government heading or sub-heading records. A screen charge applies whether or not the requested listing information was found.

(RT)(AT)
| |
(RT)(AT)
(AT)

18.9 Rates and Charges

(RT)
|
(RT)

(FC) A. DirectLine-Custom Specific

1. <u>Service Establishment Charge</u>	Nonrecurring <u>Charge</u>	
- Initial Charge	(CR) \$ 205.00	
2. <u>User ID Charge</u>	First <u>User ID</u>	Additional <u>User ID</u>
- Per User ID	\$ 8.80	\$.30
3. <u>Screen Charge</u>	Recurring <u>Charge</u>	
- Per Screen	(CR) \$.15	

Issued: January 13, 1995

Effective: February 13, 1995

By HORACE WILKINS, JR., President-Missouri
Southwestern Bell Telephone Company
St. Louis, Missouri

No supplement to this tariff will be issued except for the purpose of canceling this tariff.

Access Services Tariff
Section 18
Original Sheet 9

ACCESS SERVICES

RECEIVED

JUL 6 1990

(NR) 18. DIRECTLINE-CUSTOM (Continued)

MISSOURI
Public Service Commission

18.8 Rate Regulations (Continued)

2. Recurring

This charge applies specifically to the DirectLine-Custom service.

A. Screen Charge

This charge is applied per screen requested by the customer. A screen contains from 1 to 11 lines of listing information including name, address, and telephone number. However, a screen charge applies whether or not the requested listing information was found.

18.9 Rates and Charges

A. Packet Access

MICROLINK II rates and charges will apply for DirectLine-Custom as set forth in Section 16, preceding.

B. DirectLine-Custom Specific

1. Service Establishment Charge

Nonrecurring
Charge

- Initial Charge

\$ 4,152.45

2. User ID Charge

First
User ID

Additional
User ID

- Per User ID

\$ 8.80

\$.30

3. Screen Charge

Recurring
Charge

- Per Screen

\$.13

CANCELLED

FEB 10 1995

BY let R.S. 9
Public Service Commission
MISSOURI

FILED

AUG 17 1990

Public Service Commission

Issued: JUL 17 1990

Effective: AUG 17 1990

By: R. D. BARRON, President-Missouri Division
Southwestern Bell Telephone Company
St. Louis, Missouri

No Supplement to this tariff will be issued except for the purpose of canceling this tariff.

Access Services Tariff
Section 19
2nd Revised Sheet 1
Replacing 1st Revised Sheet 1

ACCESS SERVICES

(CT) 19. NETWORK MANAGEMENT SERVICES

The following list matches the Telephone Company's Basic Service Element (BSE) names to the industry standard names for each BSE.

Telephone Company Names

Generic Name of ONA Service

Network Reconfiguration

Network Reconfiguration

Issued: August 26, 1994

Effective: September 26, 1994

By M. H. SCHULTEIS, Executive Director-External Affairs
Southwestern Bell Telephone
St. Louis, Missouri

No supplement to this tariff will be issued except for the purpose of canceling this tariff.

Access Services Tariff
Section 19
1st Revised Sheet 1
Replacing Original Sheet 1

ACCESS SERVICES

MAR 29 1993

(C) 19. NETWORK RECONFIGURATION SERVICE

(AT)

The following list matches the Telephone Company's Basic Service Element (BSE) names to the industry standard names for each BSE.

(AT)

Telephone Company Names

Generic Name of ONA Service

(MT)

Network Reconfiguration

Network Reconfiguration

CANCELLED

SEP 26 1994
BY 2nd R.S. #1
Public Service Commission
MISSOURI

FILED

APR 11 1993
92-304

MO. PUBLIC SERVICE COM.

Issued: MAR 26 1993

Effective: APR 11 1993

By R. D. BARRON, President-Missouri Division
Southwestern Bell Telephone Company
St. Louis, Missouri

No supplement to this tariff will be issued except for the purpose of canceling this tariff.

Access Services Tariff
Section 19
Original Sheet 1
RECEIVED

ACCESS SERVICES

MAY 29 1991

19. NETWORK CONFIGURATION SERVICE

19.1 General Description

MISSOURI
Public Service Commission

Network Reconfiguration Service permits customers to access a database maintained by the Telephone Company to reconfigure their Special Access network. Customers gain database access through the use of a terminal on their premises without going through normal service order procedures.

19.2 Service Description

Network Reconfiguration Service allows customers direct access to, and control of, their DS1 channels and subtending channels without going through normal service order procedures. Network Reconfiguration utilizes a central office cross-connect system for the remote reconfiguration of these channels. The cross-connect devices currently utilized by the Telephone Company for Network Reconfiguration Service are Digital Cross-Connect Systems, (DCSs) which interface only with the DS1 (1.544 Mbps) signal and switch internally at the DS0 rate. Customers can reconfigure their Special Access Service network from their premises, or they can have the Telephone Company perform the reconfigurations.

Customers will access Network Reconfiguration Service by using a terminal on their premises in conjunction with dedicated lines provided for in Sections 7 and 16, preceding, a private line circuit provided for in P.S.C. Mo.-No. 29, Private Line Service Tariff, Digital Link Services Tariff, P.S.C. Mo.-No. 38, Section 3, or in conjunction with a local telephone line with a seven-digit telephone number.

Network Reconfiguration Service is available at those Hubs where Telephone Company cross-connect systems are located. Network Reconfiguration Hub designations are found in the National Exchange Carrier Association, Inc. Tariff filed with the F.C.C.

CANCELLED
APR 11 1993
BY let R.S. #1
Public Service Commission
MISSOURI

Issued: JUN 04 1991

Effective: AUG 05 1991

By R. D. BARRON, President-Missouri Division
Southwestern Bell Telephone Company
St. Louis, Missouri

FILED
AUG 5 1991

Public Service Commission

No Supplement to this tariff will be issued except for the purpose of canceling this tariff.

Access Services Tariff
Section 19
1st Revised Sheet 1.01
Replacing Original Sheet 1.01

ACCESS SERVICES

(AT) 19. NETWORK MANAGEMENT SERVICES-(Continued)

(FC) 19.1 Network Reconfiguration Service-(Continued)

(FC) 19.1.1 General Description

(CT) Network Reconfiguration Service is a BSE that permits customers to access a database maintained by the Telephone Company to reconfigure their dedicated network. Customers gain database access through the use of a terminal on their premises without going through normal service order procedures.

(RT)

(AT) Network Reconfiguration Service allows customers direct access to, and control of, their DS3 channels, DS1 channels, subtending channels and Internodal Facilities (the facilities that connect a Digital Cross-Connect System (DCS) in one central office with a Digital Cross-Connect System in another Central Office) without going through normal service order procedures. Network Reconfiguration utilizes a central office cross-connect system for the remote reconfiguration of these channels.

(RT)(CT) Customers can reconfigure their dedicated service network from their premises, or they can have the Telephone Company perform the reconfigurations.

Customers will access Network Reconfiguration Service by using a terminal on their premises in conjunction with dedicated lines provided for in Sections 7 and 16, preceding, a private line circuit provided for in P.S.C. Mo.-No. 29, Private Line Service Tariff, Digital Link Services Tariff, P.S.C. Mo.-No. 38, Section 3, or in conjunction with a local telephone line with a seven-digit telephone number.

Network Reconfiguration Service is available at those Hubs where Telephone Company cross-connect systems are located. Network Reconfiguration Hub designations are found in the National Exchange Carrier Association, Inc. Tariff filed with the F.C.C.

Issued: August 26, 1994

Effective: September 26, 1994

By M. H. SCHULTEIS, Executive Director-External Affairs
Southwestern Bell Telephone
St. Louis, Missouri

No supplement to this tariff will be issued except for the purpose of canceling this tariff.

Access Services Tariff
Section 19
Original Sheet 1.01

RECEIVED

MAR 29 1993

MISSOURI
Public Service Commission

ACCESS SERVICES

(MT) 19. NETWORK RECONFIGURATION SERVICE--(Continued)

19.1 General Description

(AT) Network Reconfiguration Service is a BSE that permits customers to access a database maintained by the Telephone Company to reconfigure their Special Access network. Customers gain database access through the use of a terminal on their premises without going through normal service order procedures.

19.2 Service Description

Network Reconfiguration Service allows customers direct access to, and control of, their DS1 channels and subtending channels without going through normal service order procedures. Network Reconfiguration utilizes a central office cross-connect system for the remote reconfiguration of these channels. The cross-connect devices currently utilized by the Telephone Company for Network Reconfiguration Service are Digital Cross-Connect Systems, (DCSs) which interface only with the DS1 (1.544 Mbps) signal and switch internally at the DSO rate. Customers can reconfigure their Special Access Service network from their premises, or they can have the Telephone Company perform the reconfigurations.

Customers will access Network Reconfiguration Service by using a terminal on their premises in conjunction with dedicated lines provided for in Sections 7 and 16, preceding, a private line circuit provided for in P.S.C. Mo.-No. 29, Private Line Service Tariff, Digital Link Services Tariff, P.S.C. Mo.-No. 38, Section 3, or in conjunction with a local telephone line with a seven-digit telephone number.

Network Reconfiguration Service is available at those Hubs where Telephone Company cross-connect systems are located. Network Reconfiguration Hub designations are found in the National Exchange Carrier Association, Inc. Tariff filed with the F.C.C.

(MT)

CANCELLED

SEP 26 1994
BY lot R.S. 1.01
Public Service Commission
MISSOURI

FILED

APR 11 1993
92-30
MO. PUBLIC SERVICE COM. MA.

Issued: MAR 26 1993

Effective:

APR 11 1993

By R. D. BARRON, President-Missouri Division
Southwestern Bell Telephone Company
St. Louis, Missouri

No Supplement to this tariff will be issued except for the purpose of canceling this tariff.

Access Services Tariff
Section 19
2nd Revised Sheet 2
Replacing 1st Revised Sheet 2

ACCESS SERVICES

(AT) 19. NETWORK MANAGEMENT SERVICES-(Continued)

(FC) 19.1 Network Reconfiguration Service-(Continued)

(RT)

(FC) 19.1.2 Network Reconfiguration Options

Two network reconfiguration options are available to Network Reconfiguration customers:

- On-demand
- Reservation

The on-demand option will make immediate changes to the network, while the reservation option will be executed at a specified time designated by the customer. Both types of reconfigurations are available whether the customer performs the reconfigurations or requests the Telephone Company to perform them.

(FC) 19.1.3 Network Reconfiguration Functions

Network Reconfiguration Services provides the following functions:

(AT) A. Routing/Rerouting

(CT) The routing feature allows customers to select the routes that will be used to connect their circuits between DCSs. The route selection process can be controlled by various parameters according to the customer's needs. Rerouting of circuits off of a failed internodal facility to a working one is also available.

(CT)

B. Renaming

Renaming permits customers to rename their network locations, circuits and facilities.

C. Special Day Definition

Special day definition gives customers the capability to specify circuit reconfiguration on special dates, e.g., payday, holidays.

D. Resource Verification

Resource verification allows customers to verify the resource availability for the reservation period in their reconfiguration request prior to the system's confirmation or denial of the request.

Issued: August 26, 1994 Effective: September 26, 1994
 By M. H. SCHULTEIS, Executive Director-External Affairs
 Southwestern Bell Telephone
 St. Louis, Missouri

No supplement to this tariff will be issued except for the purpose of canceling this tariff.

Access Services Tariff
Section 19
1st Revised Sheet 2
Replacing Original Sheet 2

ACCESS SERVICES

19. NETWORK RECONFIGURATION SERVICE-(Continued)

19.2 Service Description-(Continued)

19.2.1 Network Reconfiguration Options

Two network reconfiguration options are available to Network Reconfiguration customers:

- On-demand
- Reservation

The on-demand option will make immediate changes to the network, while the reservation option will be executed at a specified time designated by the customer. Both types of reconfigurations are available whether the customer performs the reconfigurations or requests the Telephone Company to perform them.

(CT) 19.2.2 Network Reconfiguration Functions

(CT) Network Reconfiguration Services provides the following functions:

(RT) A. Routing

(RT) Routing allows customers to reroute dedicated circuits to different locations at DS0 or DS1 bandwidth.

(RT) B. Renaming

(RT) Renaming permits customers to rename their network locations, circuits and facilities.

(RT) C. Special Day Definition

(RT) Special day definition gives customers the capability to specify circuit reconfiguration on special dates, e.g., payday, holidays.

(RT) D. Resource Verification

(RT) Resource verification allows customers to verify the resource availability for the reservation period in their reconfiguration request prior to the system's confirmation or denial of the request.

RECEIVED

MAR 29 1993

MISSOURI
Public Service Commission

CANCELLED

SEP 26 1994

BY 2nd R.S. #2
Public Service Commission
MISSOURI

FILED

APR 11 1993
92-304

Issued: MAR 26 1993

Effective: MO. PUBLIC SERVICE COM. APR 1 1993

By R. D. BARRON, President-Missouri Division
Southwestern Bell Telephone Company
St. Louis, Missouri

No supplement to this tariff will be issued except for the purpose of canceling this tariff.

Access Services Tariff
Section 19
Original Sheet 2

ACCESS SERVICES

RECEIVED

19. NETWORK RECONFIGURATION SERVICE-(Continued)

MAY 29 1991

19.2 Service Description-(Continued)

MISSOURI

19.2.1 Network Reconfiguration Options

Public Service Commission

Two network reconfiguration options are available to Network Reconfiguration customers:

- On-demand
- Reservation

The on-demand option will make immediate changes to the network, while the reservation option will be executed at a specified time designated by the customer. Both types of reconfigurations are available whether the customer performs the reconfigurations or requests the Telephone Company to perform them.

19.2.2 Network Reconfiguration Features

Network Reconfiguration Services provides the following features:

A. Routing Feature

The routing feature allows customers to reroute dedicated circuits to different locations at DS0 or DS1 bandwidth.

B. Renaming Feature

The renaming feature permits customers to rename their network locations, circuits and facilities.

C. Special Day Definition Feature

The special day definition feature gives customers the capability to specify circuit reconfiguration on special dates, e.g., payday, holidays.

D. Resource Verification Feature

The resource verification feature allows customers to verify the resource availability for the reservation period in their reconfiguration request prior to the system's confirmation or denial of the request.

CANCELLED

APR 11 1993
BY *let R.S. #2*

Public Service Commission
MISSOURI

Issued: JUN 04 1991

Effective: AUG 05 1991

By R. D. BARRON, President-Missouri Division
Southwestern Bell Telephone Company
St. Louis, Missouri

FILED

AUG 5 1991

Public Service Commission

No Supplement to this tariff will be issued except for the purpose of canceling this tariff.

Access Services Tariff
Section 19
2nd Revised Sheet 3
Replacing 1st Revised Sheet 3

ACCESS SERVICES

(AT) 19. NETWORK MANAGEMENT SERVICES-(Continued)

(FC) 19.1 Network Reconfiguration Service-(Continued)

(RT)

(FC) 19.1.3 Network Reconfiguration Functions-(Continued)

E. Transaction Log

Transaction log provides customers a data base log that contains every transaction involving reconfigurations.

F. Multilevel Security

Multilevel security eliminates the outside entry into a customer's circuit network arrangement inventory.

G. Compatibility Table

Compatibility table permits customers to view the allowable access line combinations that can be used with Network Reconfiguration Service.

H. Path Priority

Path priority gives customers the ability to arrange their circuit paths in order of priority when multiple routes exist.

I. Reservation Summary Screen

Reservation summary screen allows customers to view the status of their reconfiguration reservations.

J. Simple Commands and Screens

Simple commands and screens permits customers to use simple commands on screens with easy to use menus.

K. MACRO Command/Network Modeling

MACRO command/network modeling gives customers the ability to initiate with one command, multiple two-point cross-connections. Customers can build separate network models, such as daytime models, nighttime models, and disaster recovery models and invoke their activation or switch from one to the other.

Issued: August 26, 1994

Effective: September 26, 1994

By M. H. SCHULTEIS, Executive Director-External Affairs
Southwestern Bell Telephone
St. Louis, Missouri

No supplement to this tariff will be issued except for the purpose of canceling this tariff.

Access Services Tariff
Section 19
1st Revised Sheet 3
Replacing Original Sheet 3

ACCESS SERVICES

19. NETWORK RECONFIGURATION SERVICE-(Continued)

RECEIVED

19.2 Service Description-(Continued)

MAR 29 1993

(CT) 19.2.2 Network Reconfiguration Functions-(Continued)

MISSOURI
Public Service Commission

(RT) E. Transaction Log

(RT) Transaction log provides customers a data base log that contains every transaction involving reconfigurations.

(RT) F. Multilevel Security

(RT) Multilevel security eliminates the outside entry into a customer's circuit network arrangement inventory.

(RT) G. Compatibility Table

(RT) Compatibility table permits customers to view the allowable access line combinations that can be used with Network Reconfiguration Service.

(RT) H. Path Priority

(RT) Path priority gives customers the ability to arrange their circuit paths in order of priority when multiple routes exist.

CANCELLED

(RT) I. Reservation Summary Screen

(RT) Reservation summary screen allows customers to view the reconfiguration reservations.

SEP 26 1994
BY 2nd R. Steif
Public Service Commission
MISSOURI

(RT) J. Simple Commands and Screens

(RT) Simple commands and screens permits customers to use simple commands on screens with easy to use menus.

(RT) K. MACRO Command/Network Modeling

(RT) MACRO command/network modeling gives customers the ability to initiate with one command, multiple two-point cross-connections. Customers can build separate network models, such as daytime models, nighttime models, and disaster recovery models and invoke their activation or switch from one to the other.

FILED

APR 11 1993

92-304

Issued: MAR 26 1993

MO. PUBLIC SERVICE COM. APR 11 1993

By R. D. BARRON, President-Missouri Division
Southwestern Bell Telephone Company
St. Louis, Missouri

No supplement to this tariff will be issued except for the purpose of canceling this tariff.

Access Services Tariff
Section 19
Original Sheet 3

ACCESS SERVICES

19. NETWORK RECONFIGURATION SERVICE--(Continued)

RECEIVED

19.2 Service Description--(Continued)

MAY 29 1991

19.2.2 Network Reconfiguration Features--(Continued)

MISSOURI
Public Service Commission

E. Transaction Log Feature

The transaction log feature provides customers a data base log that contains every transaction involving reconfigurations.

F. Multilevel Security Feature

The multilevel security feature eliminates the outside entry into a customer's circuit network arrangement inventory.

G. Compatibility Table Feature

The compatibility table feature permits customers to view the allowable access line combinations that can be used with Network Reconfiguration Service.

H. Path Priority Feature

The path priority feature gives customers the ability to arrange their circuit paths in order of priority when multiple routes exist.

CANCELLED
APR 11 1993
BY *[Signature]*
Public Service Commission
MISSOURI

I. Reservation Summary Screen Feature

The reservation summary screen feature allows customers to view the status of their reconfiguration reservations.

J. Simple Commands and Screens Feature

The simple commands and screens feature permits customers to use simple commands on screens with easy to use menus.

K. MACRO Command/Network Modeling Feature

The MACRO command/network modeling feature gives customers the ability to initiate with one command, multiple two-point cross-connections. Customers can build separate network models, such as daytime models, nighttime models, and disaster recovery models and invoke their activation or switch from one to the other.

Issued: JUN 04 1991

Effective: AUG 05 1991

By R. D. BARRON, President-Missouri Division
Southwestern Bell Telephone Company
St. Louis, Missouri

FILED

AUG 5 1991

Public Service Commission

No Supplement to this tariff will be issued except for the purpose of canceling this tariff.

Access Services Tariff
Section 19
2nd Revised Sheet 4
Replacing 1st Revised Sheet 4

ACCESS SERVICES

(AT) 19. NETWORK MANAGEMENT SERVICES-(Continued)

(FC) 19.1 Network Reconfiguration Service-(Continued)

(RT)

(FC) 19.1.3 Network Reconfiguration Functions-(Continued)

L. Variable Bandwidth

Variable bandwidth supports scheduled reconfiguration which allows for the interchangeable use of a DS1 as either a full DS1 or one or more subtending channels.

(FC) 19.1.4 Technical Specifications

Services that are cross-connected by Network Reconfiguration Service must have identical technical characteristics to ensure compatibility and proper operation, e.g., Data-to-Data, Voice-to-Voice.

Network Reconfiguration Service specifications are delineated in Technical Reference TR-TSY-000366.

(FC) 19.1.5 Rate Regulations

This section contains a description of the rate elements applicable to Network Reconfiguration Service. Rate applications specific to this service are also included.

(FC) A. Rate Element Descriptions

(FC) 1. Service Establishment

The Service Establishment charge applies per customer database setup. The customer database setup is a grid, built by the Telephone Company, that contains all the circuits the customer will be able to control and reconfigure. Security, as well as circuit inventory, is built into the grid, permitting the customer control of its own circuits. Also included is the provisioning of customer training. This charge includes the connection of the initial circuits.

(AT)

(AT)

Issued: August 26, 1994

Effective: September 26, 1994

By M. H. SCHULTEIS, Executive Director-External Affairs
Southwestern Bell Telephone
St. Louis, Missouri

No supplement to this tariff will be issued except for the purpose of canceling this tariff.

Access Services Tariff
Section 19
1st Revised Sheet 4
Replacing Original Sheet 4

ACCESS SERVICES

19. NETWORK RECONFIGURATION SERVICE-(Continued)

19.2 Service Description-(Continued)

(CT) 19.2.2 Network Reconfiguration Functions-(Continued)

(RT) L. Variable Bandwidth

(RT) Variable bandwidth supports scheduled reconfiguration which allows for the interchangeable use of a DS1 as either a full DS1 or one or more subtending channels.

19.3 Technical Specifications

Services that are cross-connected by Network Reconfiguration Service must have identical technical characteristics to ensure compatibility and proper operation, e.g., Data-to-Data, Voice-to-Voice.

Network Reconfiguration Service specifications are delineated in Technical Reference TR-TSY-000366.

19.4 Rate Regulations

This section contains a description of the rate elements applicable to Network Reconfiguration Service. Rate applications specific to this service are also included.

19.4.1. Rate Element Descriptions

A. Service Establishment

The Service Establishment charge applies per customer database setup. The customer database setup is a grid, built by the Telephone Company, that contains all the circuits the customer will be able to control and reconfigure. Security, as well as circuit inventory, is built into the grid, permitting the customer control of its own circuits. Also included is the provisioning of customer training.

RECEIVED

MAR 29 1993

MISSOURI
Public Service Commission

CANCELLED

SEP 26 1994
BY 2nd R.S.F.
Public Service Commission

FILED

APR 11 1993

92 - 304

MO. PUBLIC SERVICE COM. MA.

Issued: MAR 26 1993

Effective:

APR 11 1993

By R. D. BARRON, President-Missouri Division
Southwestern Bell Telephone Company
St. Louis, Missouri

No supplement to this tariff will be issued except for the purpose of canceling this tariff.

Access Services Tariff
Section 19
Original Sheet 4

ACCESS SERVICES

19. NETWORK RECONFIGURATION SERVICE-(Continued)

RECEIVED

19.2 Service Description-(Continued)

MAY 29 1991

19.2.2 Network Reconfiguration Features-(Continued)

MISSOURI
Public Service Commission

L. Variable Bandwidth Feature

The variable bandwidth feature supports scheduled reconfiguration which allows for the interchangeable use of a DS1 as either a full DS1 or one or more subtending channels.

19.3 Technical Specifications

Services that are cross-connected by Network Reconfiguration Service must have identical technical characteristics to ensure compatibility and proper operation, e.g., Data-to-Data, Voice-to-Voice.

Network Reconfiguration Service specifications are delineated in Technical Reference TR-TSY-000366.

19.4 Rate Regulations

This section contains a description of the rate elements applicable to Network Reconfiguration Service. Rate applications specific to this service are also included.

19.4.1. Rate Element Descriptions

A. Service Establishment

The Service Establishment charge applies per customer database setup. The customer database setup is a grid, built by the Telephone Company, that contains all the circuits the customer will be able to control and reconfigure. Security, as well as circuit inventory, is built into the grid, permitting the customer control of its own circuits. Also included is the provisioning of customer training.

CANCELLED
APR 11 1993
BY *lat R.S. #4*
Public Service Commission
MISSOURI

Issued: JUN 0 1 1991

Effective: AUG 0 5 1991

By R. D. BARRON, President-Missouri Division
Southwestern Bell Telephone Company
St. Louis, Missouri

FILED

AUG 5 1991

Public Service Commission

No Supplement to this tariff will be issued except for the purpose of canceling this tariff.

Access Services Tariff
Section 19
1st Revised Sheet 5
Replacing Original Sheet 5

ACCESS SERVICES

(AT) 19. NETWORK MANAGEMENT SERVICES-(Continued)

(FC) 19.1 Network Reconfiguration Service-(Continued)

(FC) 19.1.5 Rate Regulations-(Continued)

(FC) A. Rate Element Descriptions-(Continued)

(FC) 2. Database Modification

This charge applies (per customer contact, or request) each time the customer requests a subsequent modification of its database grid. A modification can be an addition or deletion of circuits terminating on the cross-connect system, or a rearrangement of the database grid, e.g., an outside move, the rearrangement of the customer's routing priority, or change in application of a DS1 (from all data to all voice).

(FC) 3. Port Charges

Port Charges apply per port termination on the cross-connect system. There are three types of charges:

(CT) - DSO Port Charge - applies per channel port termination for all Special Access Services (other than High Capacity Service or DS3 Service) per circuit on the cross-connect system.

(AT) - DS1 Port Charge - applies for 1.544 Mbps channel port termination per circuit on the cross-connect system.

(AT) - DS3 Port Charge - applies for 45 Mbps channel port termination per circuit on the cross-connect system.

(FC) 4. Reconfiguration Charges

(AT) Full DS3 or DS1 bandwidth, sub DS3 or DS1 bandwidth, contiguous DS0 groupings (up to and including all 24 DS0s within a DS1), contiguous DS1 groupings (up to and including all 28 DS1s within a DS3), or individual DS0 or DS1 arrangements are as specified by the customer at the time NRS service is established. This specification limits the parameters within which the service can be reconfigured and defines how the reconfiguration charges will apply. If reconfiguration is at the DS0, DS1, or DS3 level, one reconfiguration charges applies per DS0, DS1, or DS3 circuit reconfigured; if reconfiguration is for a previously defined contiguous group of DS0s, one reconfiguration charges applies per group of DS0s reconfigured; etc.

Issued: August 26, 1994 Effective: September 26, 1994
By M. H. SCHULTEIS, Executive Director-External Affairs

Southwestern Bell Telephone
St. Louis, Missouri

No supplement to this tariff will be issued except for the purpose of canceling this tariff.

Access Services Tariff
Section 19
Original Sheet 5

ACCESS SERVICES

19. NETWORK RECONFIGURATION SERVICE-(Continued)

RECEIVED

19.4 Rate Regulations-(Continued)

MAY 29 1991

19.4.1 Rate Element Descriptions-(Continued)

MISSOURI

B. Database Modification

Public Service Commission

This charge applies (per customer contact, or request) each time the customer requests a subsequent modification of its database grid. A modification can be an addition or deletion of circuits terminating on the cross-connect system, or a rearrangement of the database grid, e.g., an outside move, the rearrangement of the customer's routing priority, or change in application of a DS1 (from all data to all voice).

C. Port Charges

Port Charges apply per port termination on the cross-connect system. There are two types of charges:

- Channel Port Charge - channel port termination for all Special Access Services other than High Capacity Service
- DS1 Port Charge - 1.544 Mbps channel port termination

D. Reconfiguration Charges

A reconfiguration charge applies per cross-connect and/or disconnect successfully completed in a DCS per request. There are two types of reconfiguration charges:

- For individual reservation or demand requests performed by the customer, or for each segment of a model request performed by the customer or Telephone Company.
- For individual reservation or demand requests performed by the Telephone Company at the customer's request.

CANCELLED

SEP 26 1994
BY let R. S. #5
Public Service Commission
MISSOURI

Issued: JUN 04 1991

Effective: AUG 05 1991

By R. D. BARRON, President-Missouri Division
Southwestern Bell Telephone Company
St. Louis, Missouri

FILED

AUG 5 1991

Public Service Commission

No Supplement to this tariff will be issued except for the purpose of canceling this tariff.

ACCESS SERVICES

(AT) 19. NETWORK MANAGEMENT SERVICES-(Continued)

19.1 Network Reconfiguration Service-(Continued)

19.1.5 Rate Regulations-(Continued)

(AT) 4. Reconfiguration Charges-(Continued)

(MT) One reconfiguration charge applies per cross-connect and/or disconnect successfully completed in a DCS per request. There are two types of reconfiguration charges:

- For individual reservation or demand requests performed by the customer, or for each segment of a model request performed by the customer or Telephone Company.

(MT) - For individual reservation or demand requests performed by the Telephone Company at the customer's request.

(AT) For example, if a customer wishes to reconfigure a circuit that is routed through two NRS Hub offices (the existing circuit being routed between customer premises A through the two NRS Hub offices to customer premises B, and the customer wishes to reconfigure the circuit to be rerouted between customer premises A through the two NRS Hub offices to customer premises C), two transactions would occur: one transaction to disconnect the circuit between premises A and B, and one transaction to reconnect the circuit between premises A and C. The customer would be billed four NRS charges: two for disconnecting the circuit (one for each disconnect at each NRS Hub), and two for reconnecting the circuit (one for each reconnect at each NRS Hub).

Issued: August 26, 1994

Effective: September 26, 1994

By M. H. SCHULTEIS, Executive Director-External Affairs
Southwestern Bell Telephone
St. Louis, Missouri

No Supplement to this tariff will be issued except for the purpose of canceling this tariff.

Access Services Tariff
Section 19
1st Revised Sheet 6
Replacing Original Sheet 6

ACCESS SERVICES

(AT) 19. NETWORK MANAGEMENT SERVICES-(Continued)

(FC) 19.1 Network Reconfiguration Service-(Continued)

(FC) 19.1.5 Rate Regulations-(Continued)

(FC) B. Rate Applications

When Network Reconfiguration Service is used in conjunction with Special Access Services, the applicable rate elements per circuit are set forth in Section 7, Paragraph 7.5, preceding:

- One Channel Termination (CT) applies between the customer premises and service wire center.
- Channel Mileage, if applicable, applies between the serving wire center and the Telephone Company Network Reconfiguration Hub, or between two Network Reconfiguration Hubs.

(RT)

Nonrecurring charges, as set forth in Section 7, Paragraph 7.4.1, preceding, are also applicable when existing channels must be reterminated in a Network Reconfiguration Port to provide Network Reconfiguration Service.

(RT)

|
|

(RT)

(RT)

Issued: August 26, 1994

Effective: September 26, 1994

By M. H. SCHULTEIS, Executive Director-External Affairs
Southwestern Bell Telephone
St. Louis, Missouri

No supplement to this tariff will be issued except for the purpose of canceling this tariff.

Access Services Tariff
Section 19
Original Sheet 6

ACCESS SERVICES

RECEIVED

19. NETWORK RECONFIGURATION SERVICE-(Continued)

MAY 29 1991

19.4 State Regulations-(Continued)

MISSOURI

19.4.2 Rate Applications

Public Service Commission

When Network Reconfiguration Service is used in conjunction with Special Access Services, the applicable rate elements per circuit are set forth in Section 7, Paragraph 7.5, preceding:

- One Channel Termination (CT) applies between the customer premises and service wire center.
- Channel Mileage, if applicable, applies between the serving wire center and the Telephone Company Network Reconfiguration Hub, or between two Network Reconfiguration Hubs.(1)

Nonrecurring charges, as set forth in Section 7, Paragraph 7.4.1, preceding, are also applicable when existing channels must be reterminated in a Network Reconfiguration Port to provide Network Reconfiguration Service.

One Network Reconfiguration Port Charge applies per circuit at the Network Reconfiguration Hub. In addition, two Port Charges apply per DS1 circuit connecting the Hubs, one port charge at each termination of the DS1.

CANCELLED

SEP 26 1994
BY *124 R.S. #6*
Public Service Commission
MISSOURI

(1) The Channel Mileage between two Network Reconfiguration Hubs must be at 1.544 Mbps.

Issued: JUN 04 1991

Effective: AUG 05 1991

FILED

By R. D. BARRON, President-Missouri Division
Southwestern Bell Telephone Company
St. Louis, Missouri

AUG 5 1991

Public Service Commission

No Supplement to this tariff will be issued except for the purpose of canceling this tariff.

Access Services Tariff
Section 19
1st Revised Sheet 7
Replacing Original Sheet 7

ACCESS SERVICES

(AT) 19. NETWORK MANAGEMENT SERVICES-(Continued)

(FC) 19.1 Network Reconfiguration Service-(Continued)

(FC) 19.1.5 Rate Regulations-(Continued)

(FC) C. Service Configurations

The following diagram depicts a typical Network Reconfiguration Network with its applicable rate elements:

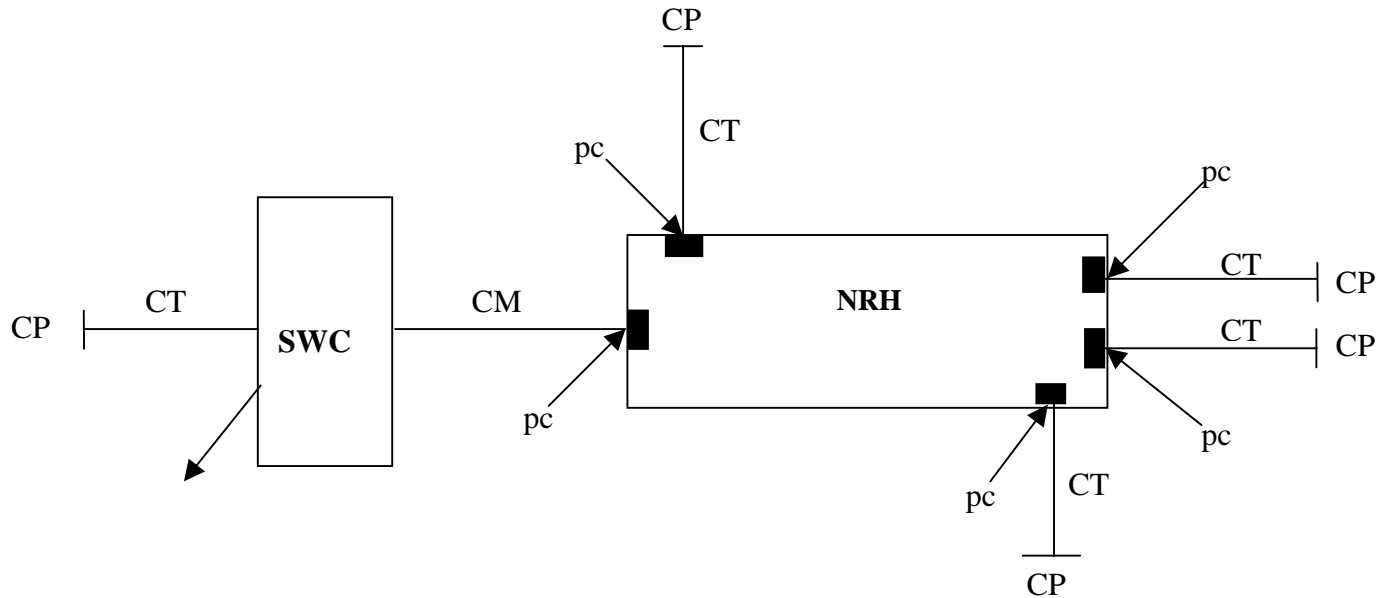

- CM = Channel Mileage
- CP = Customer Premises
- CT = Channel Termination
- NRH = Network Reconfiguration Hub
- PC = Port Charge
- SWC = Serving Wire Center

Issued: August 26, 1994

Effective: September 26, 1994

By M. H. SCHULTEIS, Executive Director-External Affairs
Southwestern Bell Telephone
St. Louis, Missouri

No supplement to this tariff will be issued except for the purpose of canceling this tariff.

Access Services Tariff
Section 19
Original Sheet 7

ACCESS SERVICES

19. NETWORK RECONFIGURATION SERVICE-(Continued)

RECEIVED

19.4 Rate Regulations-(Continued)

MAY 29 1991

19.4.3 Service Configurations

MISSOURI
Public Service Commission

The following diagram depicts a typical Network Reconfiguration Network with its applicable rate elements:

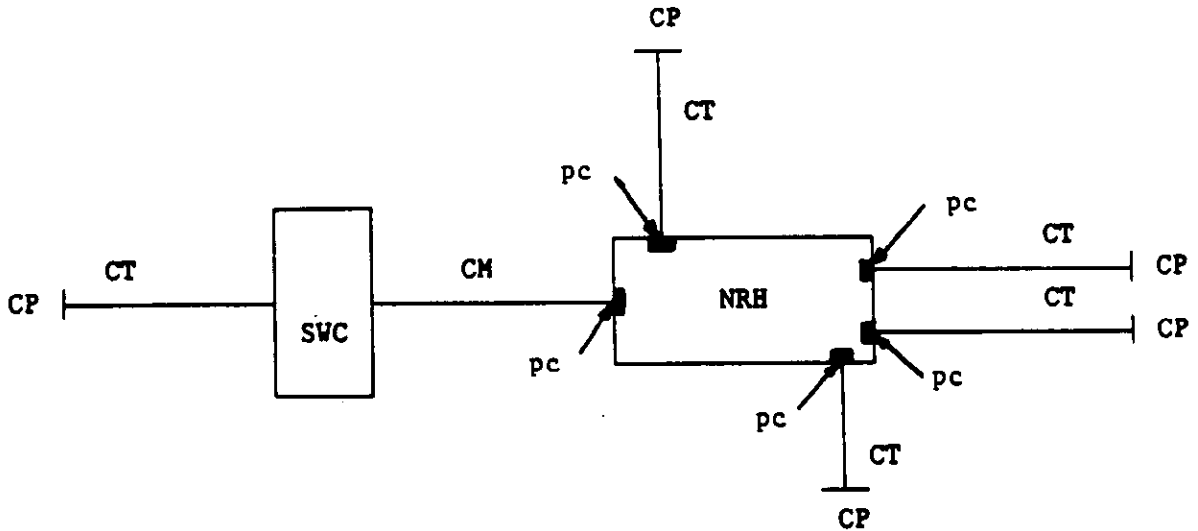

- CM = Channel Mileage
- CP = Customer Premises
- CT = Channel Termination
- NRH = Network Reconfiguration Hub
- PC = Port Charge
- SWC = Serving Wire Center

CANCELLED

SEP 26 1994
BY 1st R.S. #7
Public Service Commission
MISSOURI

Issued: JUN 0 4 1991

Effective: AUG 0 5 1991

By R. D. BARRON, President-Missouri Division
Southwestern Bell Telephone Company
St. Louis, Missouri

FILED

AUG 5 1991

Public Service Commission

No Supplement to this tariff will be issued except for the purpose of canceling this tariff.

Access Services Tariff
Section 19
1st Revised Sheet 8
Replacing Original Sheet 8

ACCESS SERVICES

(AT) 19. NETWORK MANAGEMENT SERVICES-(Continued)

(FC) 19.1 Network Reconfiguration Service-(Continued)

(FC) 19.1.5 Rate Regulations-(Continued)

(FC) C. Service Configurations

The following diagram depicts a Network Reconfiguration Network utilizing two Network Reconfiguration Hubs:

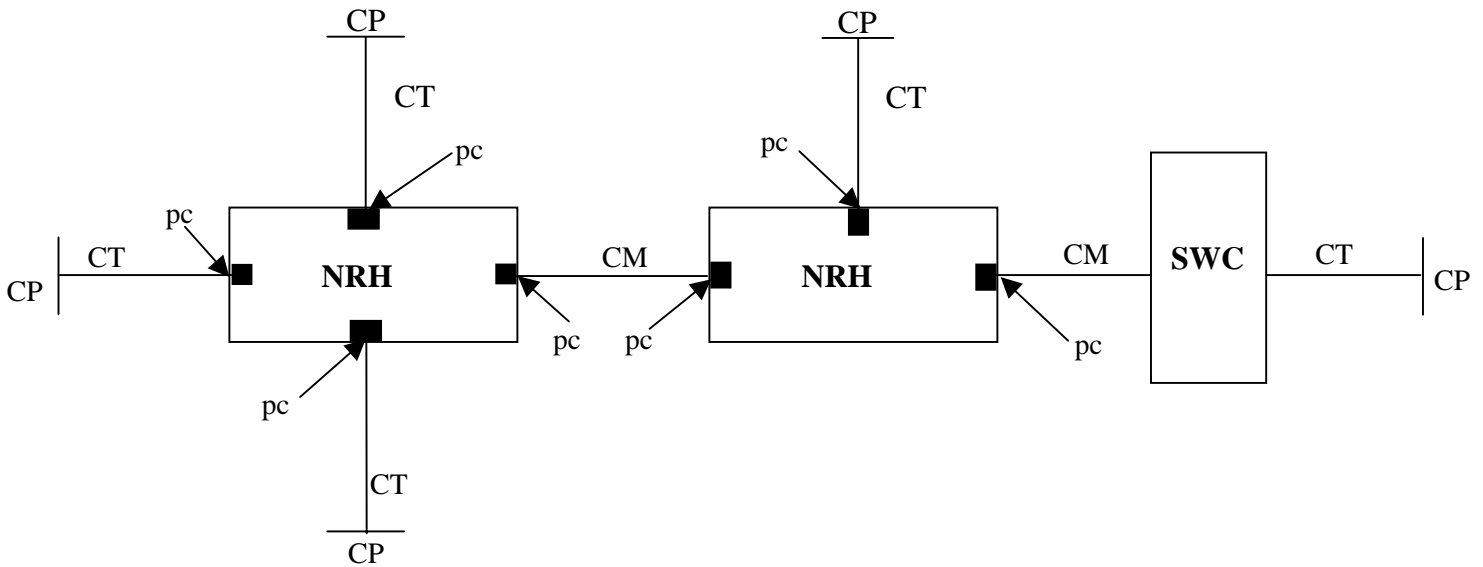

- CM = Channel Mileage
- CP = Customer Premises
- CT = Channel Termination
- NRH = Network Reconfiguration Hub
- PC = Port Charge
- SWC = Serving Wire Center

Issued: August 26, 1994

Effective: September 26, 1994

By M. H. SCHULTEIS, Executive Director-External Affairs
Southwestern Bell Telephone
St. Louis, Missouri

No supplement to this tariff will be issued except for the purpose of canceling this tariff.

Access Services Tariff
Section 19
Original Sheet 8

ACCESS SERVICES

19. NETWORK RECONFIGURATION SERVICE--(Continued)

RECEIVED

19.4 Rate Regulations--(Continued)

MAY 29 1991

19.4.3 Service Configurations--(Continued)

MISSOURI

The following diagram depicts a Network Reconfiguration Network utilizing two Network Reconfiguration Hubs:

Public Service Commission

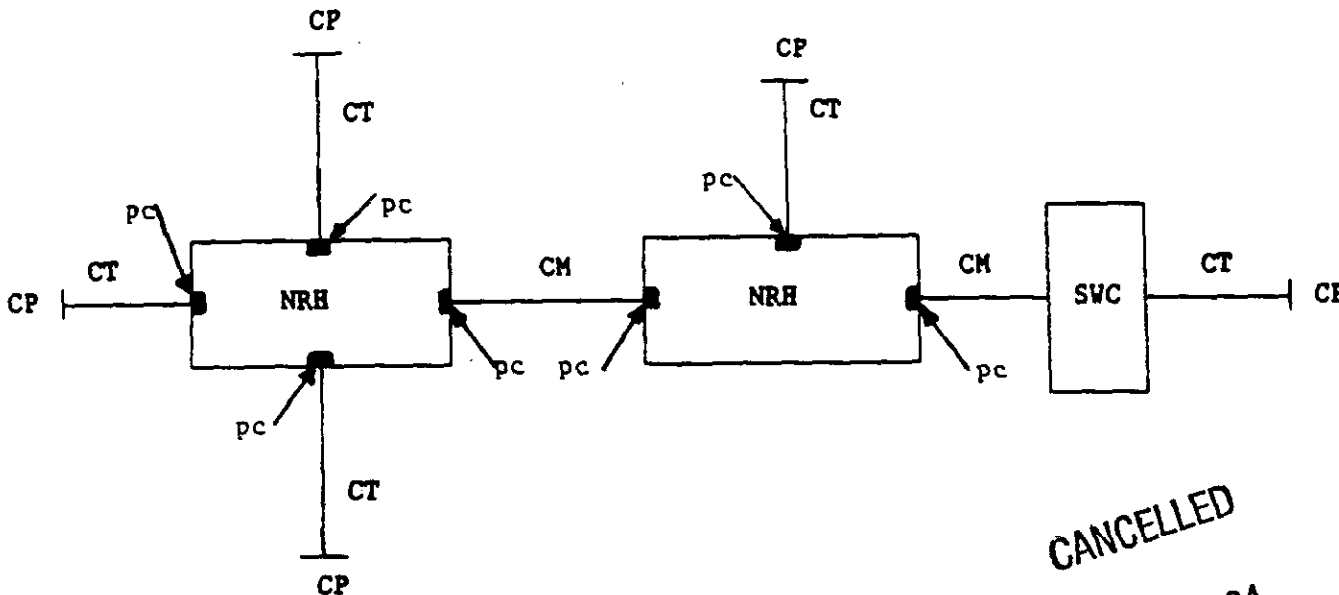

- CM = Channel Mileage
- CP = Customer Premises
- CT = Channel Termination
- NRH = Network Reconfiguration Hub
- PC = Port Charge
- SWC = Serving Wire Center

CANCELLED

SEP 26 1994
BY *let R.S. #8*
Public Service Commission
MISSOURI

Issued: JUN 04 1991

Effective: AUG 05 1991

By R. D. BARRON, President-Missouri Division
Southwestern Bell Telephone Company
St. Louis, Missouri

FILED

AUG 5 1991

Public Service Commission

No Supplement to this tariff will be issued except for the purpose of canceling this tariff.

Access Services Tariff
Section 19
1st Revised Sheet 9
Replacing Original Sheet 9

ACCESS SERVICES

(AT) 19. NETWORK MANAGEMENT SERVICES-(Continued)

(FC) 19.1 Network Reconfiguration Service-(Continued)

(FC) 19.1.6 Rates and Charges

(RT)

	<u>USOC</u>	<u>Monthly Rates</u>	<u>Nonrecurring Charges</u>
--	-------------	----------------------	-----------------------------

A. Service Establishment

(AT)	- Per Database Setup	FN6DD	None	(CR)\$1,722.00
------	----------------------	-------	------	----------------

(AT)	B. Database Modification, - per request	FN6DC	None	(CR)\$ 80.00
------	--	-------	------	--------------

C. Port Charges

(CT)(AT)	- DS0 Port	PT5	(CR)\$ 11.03	(CR)\$ 20.00
----------	------------	-----	--------------	--------------

(AT)	- DS1 Port	PT6	(CR)\$ 45.14	(CR)\$ 43.00
------	------------	-----	--------------	--------------

(AT)	- DS3 Port	D3D	(NR)\$500.00	(NR)\$ 32.00
------	------------	-----	--------------	--------------

D. Reconfiguration Charges

(AT)	Per Cross-Connect and/or Disconnect Successfully Completed
------	--

(AT)	- Per Reconfiguration Performed by Customer; or Each Segment of a Model Request Performed by Customer or Telephone Company		None	(CR)\$ 1.25
------	--	--	------	-------------

(AT)	- Per Reconfiguration Performed by the Telephone Company at Customer Request		None	(CR)\$ 8.00
------	--	--	------	-------------

Issued: August 26, 1994	Effective: September 26, 1994
-------------------------	-------------------------------

By M. H. SCHULTEIS, Executive Director-External Affairs
Southwestern Bell Telephone
St. Louis, Missouri

No supplement to this tariff will be issued except for the purpose of canceling this tariff.

Access Services Tariff
Section 19
Original Sheet 9

ACCESS SERVICES

RECEIVED

19. NETWORK RECONFIGURATION SERVICE-(Continued)

MAY 29 1991

19.5 Rates and Charges

MISSOURI

19.5.1 Network Reconfiguration Service Rate Elements Public Service Commission

	<u>USOC</u>	<u>Monthly Rates</u>	<u>Nonrecurring Charges</u>
A. Service Establishment			
- Per Database Setup		None	\$1,851.00
B. Database Modification, - per request		None	\$ 64.00
C. Port Charges			
- Channel Port		\$ 7.55	\$ 8.00
- DS1 Port		\$33.25	\$ 26.00
D. Reconfiguration Charges			
- Per Reconfiguration Performed by Customer		None	\$ 2.00
- Per Reconfiguration Performed by the Telephone Company at Customer Request		None	\$ 5.00

CANCELLED

SEP 26 1994
BY 1st R.S. #9
Public Service Commission
MISSOURI

Issued: JUN 04 1991

Effective: AUG 05 1991

By R. D. BARRON, President-Missouri Division
Southwestern Bell Telephone Company
St. Louis, Missouri

FILED

AUG 5 1991

Public Service Commission

No Supplement to this tariff will be issued except for the purpose of canceling this tariff.

Access Services Tariff
Section 19
2nd Revised Sheet 10
Replacing 1st Revised Sheet 10

ACCESS SERVICES

19. NETWORK MANAGEMENT SERVICES (cont'd)

(RT)

(RT)

Issued: January 3, 2003

Effective: February 2, 2003

By CINDY BRINKLEY, President-Missouri
Southwestern Bell Telephone, L.P., d/b/a SBC Missouri
St. Louis, Missouri

No supplement to this tariff will be issued except for the purpose of canceling this tariff.

Access Services Tariff
Section 19
1st Revised Sheet 10
Replacing Original Sheet 10

RECEIVED

ACCESS SERVICES

JAN 10 1997

**MISSOURI
Public Service Commission**

19. NETWORK MANAGEMENT SERVICES-(Continued)

19.2 Transport Resource Management (TRM) Service

19.2.1 General

(RT)

Transport Resource Management (TRM) is a bandwidth management service that provides integrated data, voice, and video multiplexing with subrate multiplexing, voice compression, voice and data bridging, fault tolerance, and advanced customer network management capability. TRM interfaces with the following access services: Voice Grade, MegaLink Data and High Capacity. These access services are found in Section 7 of this tariff.

Customers may elect to manage their TRM service via a workstation on their premises, or may order Network Modifications from the Telephone Company.

TRM is provided at those TRM Service Hub designations listed in the National Exchange Carrier Association, Inc. Tariff F.C.C. No. 4.

19.2.2 Standard Features

A. Intelligent Bandwidth Management

TRM manages bandwidth at 44.764 Mbps (DS3), 1.544 Mbps (DS1), NX64 kbps and 64 kbps (DS0). Subrate multiplexing is an optional feature and is available as set forth in Section 19.2.3(A). Integrated voice, data and video multiplexing are provided with drop, insert and bypass multiplexing capabilities. Circuit level switching is supported between all interfacing services at the DS0 level with very low transit delay. Non-contiguous bandwidth can be allocated in support of transmission rates above DS0.

B. Fault Tolerance

TRM monitors network occurrences and provides recovery from service-affecting network faults. In the event of a network disruption between TRM Service Hubs, TRM isolates the fault to the lowest network element possible and automatically reroutes traffic around any failed network elements.

CANCELLED

FEB 02 2003
BY *Andersia*
Public Service Commission
MISSOURI

FILED

FEB 10 1997

Issued: JAN 10 1997

Effective:

MO PUBLIC SERVICE COMM

By KAREN E. JENNINGS, President-Missouri
Southwestern Bell Telephone
St. Louis, Missouri

No supplement to this tariff will be issued except for the purpose of canceling this tariff.

Access Services Tariff
Section 19
Original Sheet 10

RECEIVED

ACCESS SERVICES

AUG 26 1994

19. NETWORK MANAGEMENT SERVICES-(Continued)

MO. PUBLIC SERVICE COMM.

19.2 Transport Resource Management (TRM) Service

19.2.1 General

Transport Resource Management (TRM) is a bandwidth management service that provides integrated data, voice, and video multiplexing with subrate multiplexing, voice compression, voice and data bridging, fault tolerance, and advanced customer network management capability. TRM interfaces with the following access services: Voice Grade, MegaLink Data, Business Video I, Business Video II and High Capacity. These access services are found in Section 7 of this tariff.

Customers may elect to manage their TRM service via a workstation on their premises, or may order Network Modifications from the Telephone Company.

TRM is provided at those TRM Service Hub designations listed in the National Exchange Carrier Association, Inc. Tariff F.C.C. No. 4.

19.2.2 Standard Features

A. Intelligent Bandwidth Management

TRM manages bandwidth at 44.764 Mbps (DS3), 1.544 Mbps (DS1), 64 kbps and 64 kbps (DS0). Subrate multiplexing is an optional feature and is available as set forth in Section 19.2.3(A). Integrated voice, data and video multiplexing are provided with drop, insert and bypass multiplexing capabilities. Circuit level switching is supported between all interfacing services at the DS0 level with very low transit delay. Non-contiguous bandwidth can be allocated in support of transmission rates above DS0.

B. Fault Tolerance

TRM monitors network occurrences and provides recovery from service-affecting network faults. In the event of a network disruption between TRM Service Hubs, TRM isolates the fault to the lowest network element possible and automatically reroutes traffic around any failed network elements.

CANCELLED
FEB 10 1997
BY: let R.S. # 10
Public Service Commission
MISSOURI

FILED

SEP 26 1994

Issued: AUG 26 1994

Effective: SEP 26 1994

By M. H. SCHULTEIS, Executive Director-External Affairs
Southwestern Bell Telephone
St. Louis, Missouri
MISSOURI
Public Service Commission

No Supplement to this tariff will be issued except for the purpose of canceling this tariff.

Access Services Tariff
Section 19
1st Revised Sheet 11
Replacing Original Sheet 11

ACCESS SERVICES

19. NETWORK MANAGEMENT SERVICES (cont'd)

(RT)

(RT)

Issued: January 3, 2003

Effective: February 2, 2003

By CINDY BRINKLEY, President-Missouri
Southwestern Bell Telephone, L.P., d/b/a SBC Missouri
St. Louis, Missouri

No supplement to this tariff will be issued except for the purpose of canceling this tariff.

Access Services Tariff
Section 19
Original Sheet 11

ACCESS SERVICES

RECEIVED

19. NETWORK MANAGEMENT SERVICES--(Continued)

AUG 26 1994

19.2 Transport Resource Management (TRM) Service--(Continued)

MO. PUBLIC SERVICE COMM.

19.2.2 Standard Features--(Continued)

B. Fault Tolerance--(Continued)

Services may be rerouted along a customer predefined alternate path, or may be automatically rerouted based upon service priorities and routing attributes associated with the individual services. Service priority and routing attributes are established by the customer. Service priority controls the order in which services are re-established. Routing attributes allow services to be biased toward or away from specific alternate paths.

C. Customer Network Management

TRM customer network management enables the customer to configure, operate, and monitor their TRM network. Specific management capabilities include reconfiguration of routing and bandwidth, view of the customer's traffic data, time-of-day event handling, alarms and trouble isolation.

Customers may elect to manage TRM services via a workstation on their premises. An extensive graphical user interface is available to simplify the network management process for the customer.

Customers must allocate a DS0 channel between TRM Service Hubs in support of these network management capabilities.

19.2.3 Optional Features

A. Subrate Multiplexing

Subrate multiplexing permits customers to switch digital data services in increments below DS0. Full multiplexing flexibility, including drop and insertion, is provided for 2.4, 4.8, and 9.6 kbps MegaLink Data services and other data rates such as 14.4 and 19.2 kbps (1). Subrate multiplexing of Analog/Voice Grade data services is not supported. Non-contiguous bandwidth can be assigned to individual subrate channels for maximum bandwidth usage.

(1) For data rates not supported in Section 7 of this tariff, those data rates must be transported via a non-channelized DS1.

FILED

Issued:

AUG 26 1994

Effective:

SEP 28 1994

SEP 26 1994

By M. H. SCHULTEIS, Executive Director-External Affairs
Southwestern Bell Telephone
St. Louis, Missouri

MISSOURI
Public Service Commission

CANCELLED

FEB 02 2003

by STS/11
Public Service Commission
MISSOURI

No Supplement to this tariff will be issued except for the purpose of canceling this tariff.

Access Services Tariff
Section 19
1st Revised Sheet 12
Replacing Original Sheet 12

ACCESS SERVICES

19. NETWORK MANAGEMENT SERVICES (cont'd)

(RT)

(RT)

Issued: January 3, 2003

Effective: February 2, 2003

By CINDY BRINKLEY, President-Missouri
Southwestern Bell Telephone, L.P., d/b/a SBC Missouri
St. Louis, Missouri

No supplement to this tariff will be issued except for the purpose of canceling this tariff.

Access Services Tariff
Section 19
Original Sheet 12

ACCESS SERVICES

RECEIVED

19. NETWORK MANAGEMENT SERVICES-(Continued)

19.2 Transport Resource Management (TRM) Service-(Continued)

AUG 26 1994

19.2.3 Optional Features-(Continued)

MO. PUBLIC SERVICE COMM.

B. Voice Compression

Adaptive Differential Pulse Code Modulation (ADPCM) provides a two-to-one (2:1) compression of voice channels with minimal reduction in voice quality. Based on the customer's network configuration, up to 44 compressed voice channels can be accommodated on a single DS1 channel across the transport network.

C. Voice and Data Bridging

Voice and data bridging supports voice conference bridging, multipoint bridging of Analog/Voice Grade data services, and multidrop data bridging of digital data services. Voice and data bridging permits many services to share the same transport bandwidth.

D. Frame Relay

With the Frame Relay option, TRM provides frame routing, dynamic bandwidth allocation, congestion control and frame error checking for up to 30 Frame Relay-compatible data streams. DS1, NX64 kbps and DS0 Frame Relay data channels can be accommodated.

19.2.4 Rate Regulations

This section contains information related to the rate elements applicable to TRM. Rates and charges associated with the rate elements are listed in 19.2.5.

A. Rate Element Description

1. Service Arrangement Charge

A Service Arrangement Charge applies at each TRM Service Hub where service is requested. Service Arrangements are provided on a month-to-month basis or for fixed service periods of 1, 3 or 5 years. Fixed service period agreements allow the customer to order TRM service with the assurance that during the fixed service period, the monthly rates for the service will not exceed the levels in effect at the time the service was established.

FILED

SEP 26 1994

CANCELLED

FEB 02 2003
BY SHASL2
Public Service Commission
MISSOURI

Issued: **AUG 26 1994**

Effective: **SEP 26 1994**

MISSOURI

By M. H. SCHULTEIS, Executive Director-External Affairs, Missouri Public Service Commission
Southwestern Bell Telephone
St. Louis, Missouri

No Supplement to this tariff will be issued except for the purpose of canceling this tariff.

Access Services Tariff
Section 19
1st Revised Sheet 13
Replacing Original Sheet 13

ACCESS SERVICES

19. NETWORK MANAGEMENT SERVICES (cont'd)

(RT)

(RT)

Issued: January 3, 2003

Effective: February 2, 2003

By CINDY BRINKLEY, President-Missouri
Southwestern Bell Telephone, L.P., d/b/a SBC Missouri
St. Louis, Missouri

No supplement to this tariff will be issued except for the purpose of canceling this tariff.

Access Services Tariff
Section 19
Original Sheet 13

ACCESS SERVICES

RECEIVED

19. NETWORK MANAGEMENT SERVICES-(Continued)

19.2 Transport Resource Management (TRM) Service-(Continued)

AUG 26 1994

19.2.4 Rate Regulations-(Continued)

MO. PUBLIC SERVICE COMM.

A. Rate Element Description-(Continued)

1. Service Arrangement Charge-(Continued)

A customer's initial order for a Service Arrangement must be for a 1, 3 or 5 year fixed service period. At the end of the fixed service period, the customer may elect to continue service under the month-to-month option, contract for another 1, 3 or 5 year period, or terminate the service.

Each Service Arrangement has the capacity to manage a fixed number of access services. If a customer exceeds the capacity of a Service Arrangement, additional Services Arrangements may be ordered, up to a maximum of eight (8) Service Arrangements per TRM Service Hub. These Service Arrangements will interoperate as a single higher capacity Service Arrangement. No interworking or switching restrictions will be encountered between Service Arrangements at the same TRM Service Hub.

There are two types of Service Arrangements available as described below:

(a) Standard Arrangement

The Standard Arrangement supports up to 30 DS1 access services, or up to 720 DS0 access services, or any combination of these access services that do not together exceed the capacity of the arrangement.

Use of subrate multiplexing, voice and data bridging or frame relay optional features (as set forth in 19.2.4(A)(4)) each consume resources of the Standard Arrangement, thereby reducing the capacity for access services. Each optional feature reduces the Standard Arrangement capacity by 2 DS1 access services or 48 DS0 access services.

CANCELLED

FEB 02 2003
By STARS/13
Public Service Commission
MISSOURI

FILED

SEP 26 1994

Issued: AUG 26 1994

Effective: SEP 26 1994

By M. H. SCHULTEIS, Executive Director-External Affairs
Southwestern Bell Telephone
St. Louis, Missouri

MISSOURI
Public Service Commission

No Supplement to this tariff will be issued except for the purpose of canceling this tariff.

Access Services Tariff
Section 19
2nd Revised Sheet 14
Replacing 1st Revised Sheet 14

ACCESS SERVICES

19. NETWORK MANAGEMENT SERVICES (cont'd)

(RT)

(RT)

Issued: January 3, 2003

Effective: February 2, 2003

By CINDY BRINKLEY, President-Missouri
Southwestern Bell Telephone, L.P., d/b/a SBC Missouri
St. Louis, Missouri

No supplement to this tariff will be issued except for the purpose of canceling this tariff.

Access Services Tariff
Section 19
1st Revised Sheet 14
Replacing Original Sheet 14

ACCESS SERVICES

RECEIVED

19. NETWORK MANAGEMENT SERVICES-(Continued)

JAN 1 0 1997

19.2 Transport Resource Management (TRM) Service-(Continued)

CANCELLED

19.2.4 Rate Regulations-(Continued)

**MISSOURI
Public Service Commission**

A. Rate Element Description-(Continued)

FEB 0 2 2003
by *WDRS14*
**MISSOURI
Public Service Commission**

I. Service Arrangement Charge-(Continued)

b. DS3 Arrangement

A DS3 Arrangement supports a single 44.736 Mbps High Capacity (DS3) access service interface. The DS3 Arrangement interfaces to the Standard Arrangement for use with DS1, DS0 and subrate access services.

2. Network Modification Charge

This charge applies each time the customer requests the Telephone Company to modify their service.

This charge is not applicable if the customer makes changes directly through their TRM network management workstation.

3. Service Interface Charges

A Service Interface Charge applies per access service interfaced at a TRM Service Hub. There are separate rate elements for DS1 (High Capacity), DS0 (MegaLink Data and Voice Grade services), and Network Management as set forth in 19.2.5(C). The Service Interface Charge is provided on a month-to-month basis only.

(RT)

a. DS1 Service Interface

A DS1 Service Interface Charge is applied for each High Capacity (DS1) access service that is interfaced to a TRM Standard Arrangement.

(RT)

b. DS0 Service Interface

A DS0 Service Interface Charge is applied for each MegaLink Data or Voice Grade access service interfaced to a TRM Standard Arrangement.

FILED

FEB 10 1997

MO. PUBLIC SERVICE COMM

Issued: JAN 1 0 1997

Effective: FEB 1 0 1997

By KAREN E. JENNINGS, President-Missouri
Southwestern Bell Telephone
St. Louis, Missouri

No supplement to this tariff will be issued except for the purpose of canceling this tariff.

Access Services Tariff
Section 19
Original Sheet 14

ACCESS SERVICES

RECEIVED

19. NETWORK MANAGEMENT SERVICES--(Continued)

19.2 Transport Resource Management (TRM) Service--(Continued)

AUG 26 1994

19.2.4 Rate Regulations--(Continued)

MO. PUBLIC SERVICE COMM.

A. Rate Element Description--(Continued)

1. Service Arrangement Charge--(Continued)

b. DS3 Arrangement

A DS3 Arrangement supports a single 44.736 Mbps High Capacity (DS3) access service interface. The DS3 Arrangement interfaces to the Standard Arrangement for use with DS1, DS0 and subrate access services.

2. Network Modification Charge

This charge applies each time the customer requests the Company to modify their service.

This charge is not applicable if the customer makes changes directly through their TRM network management workstation.

3. Service Interface Charges

A Service Interface Charge applies per access service interfaced at a TRM Service Hub. There are separate rate elements for DS1 (High Capacity, Business Video I and Business Video II services), DS0 (MegaLink Data and Voice Grade services), and Network Management as set forth in 19.2.5(C). The Service Interface Charge is provided on a month-to-month basis only.

a. DS1 Service Interface

A DS1 Service Interface Charge is applied for each High Capacity (DS1), Business Video I, or Business Video II access service that is interfaced to a TRM Standard Arrangement.

b. DS0 Service Interface

A DS0 Service Interface Charge is applied for each MegaLink Data or Voice Grade access service interfaced to a TRM Standard Arrangement.

FILED

SEP 26 1994

Issued: ~~AUG 26 1994~~

Effective: ~~SEP 26 1994~~ MISSOURI Public Service Commission

By M. H. SCHULTEIS, Executive Director-External Affairs
Southwestern Bell Telephone
St. Louis, Missouri

No Supplement to this tariff will be issued except for the purpose of canceling this tariff.

Access Services Tariff
Section 19
1st Revised Sheet 15
Replacing Original Sheet 15

ACCESS SERVICES

19. NETWORK MANAGEMENT SERVICES (cont'd)

(RT)

(RT)

Issued: January 3, 2003

Effective: February 2, 2003

By CINDY BRINKLEY, President-Missouri
Southwestern Bell Telephone, L.P., d/b/a SBC Missouri
St. Louis, Missouri

No supplement to this tariff will be issued except for the purpose of canceling this tariff.

Access Services Tariff
Section 19
Original Sheet 15

ACCESS SERVICES

RECEIVED

19. NETWORK MANAGEMENT SERVICES--(Continued)

AUG 26 1994

19.2 Transport Resource Management (TRM) Service--(Continued)

19.2.4 Rate Regulations--(Continued)

MO. PUBLIC SERVICE COMM.

A. Rate Element Description--(Continued)

3. Service Interface Charges--(Continued)

c. Network Management Service Interface

The Network Management Service Interface Charge supports a TRM network management interface to the customer's premises for use in managing the customer's TRM network. Provisioning of a network management interface permits the customer to have control of its TRM network, and to make configuration changes without incurring the TRM Network Modification Charge. The customer is responsible for providing a 56 kbps Channel Service Unit (CSU), and a workstation at its premises.

4. Optional Features

Customers may purchase optional features for Subrate Multiplexing, Voice Compression, Voice and Data Bridging, or Frame Relay services. Optional feature rate elements are applied at each TRM Service Hub where the feature is requested. Multiple optional features may be ordered at a single TRM Service Hub.

Each optional feature, with the exception of Voice Compression, reduces the capacity of the Standard Arrangement by 2 DS1 access services or 48 DS0 access services.

a. Subrate Multiplexing

Each Subrate Multiplexing optional feature supports subrate multiplexing of up to 40 subrate channels at a single TRM Service Hub.

CANCELLED

FILED

FEB 02 2003

SEP 26 1994

By *LSRS/JS*
Public Service Commission
MISSOURI

MISSOURI
Public Service Commission

Issued: **AUG 26 1994**

Effective: **SEP 26 1994**

By M. H. SCHULTEIS, Executive Director-External Affairs
Southwestern Bell Telephone
St. Louis, Missouri

No Supplement to this tariff will be issued except for the purpose of canceling this tariff.

Access Services Tariff
Section 19
1st Revised Sheet 16
Replacing Original Sheet 16

ACCESS SERVICES

19. NETWORK MANAGEMENT SERVICES (cont'd)

(RT)

(RT)

Issued: January 3, 2003

Effective: February 2, 2003

By CINDY BRINKLEY, President-Missouri
Southwestern Bell Telephone, L.P., d/b/a SBC Missouri
St. Louis, Missouri

No supplement to this tariff will be issued except for the purpose of canceling this tariff.

Access Services Tariff
Section 19
Original Sheet 16

RECEIVED

ACCESS SERVICES

AUG 26 1994

19. NETWORK MANAGEMENT SERVICES--(Continued)

19.2 Transport Resource Management (TRM) Service--(Continued)

MO. PUBLIC SERVICE COMM.

19.2.4 Rate Regulations--(Continued)

4. Optional Features--(continued)

b. Voice Compression

Each Voice Compression optional feature supports, based on the customer's network configuration, ADPCM 2:1 voice compression on up to two (2) High Capacity (DS1) access services, or a group of up to 48 Voice Grade (DS0) access services, or a single High Capacity (DS1) access service and a group of up to 24 Voice Grade access services at a TRM Service Hub.

c. Voice and Data Bridging

Each Voice and Data Bridging optional feature supports voice conferencing of up to 48 conferees on up to 24 conference bridges, or analog data bridging of up to 48 data services on up to 12 bridged circuits, or digital data bridging of up to 18 digital data services on up to 18 bridged circuits, or any combination of voice, digital data and analog data bridging that does not exceed the capacity of the feature, at a single TRM Service Hub.

d. Frame Relay

Each Frame Relay optional feature supports Frame Relay switching of up to 30 Frame Relay data streams or up to 1.9 Mbps of total Frame Relay switched bandwidth at a single TRM Service Hub.

CANCELLED

FEB 02 2003

by *STAR 5/6*
Public Service Commission
MISSOURI

FILED

SEP 26 1994

**MISSOURI
Public Service Commission**

Issued: **SEP 26 1994**

Effective: **SEP 26 1994**

By M. H. SCHULTEIS, Executive Director-External Affairs
Southwestern Bell Telephone
St. Louis, Missouri

No Supplement to this tariff will be issued except for the purpose of canceling this tariff.

Access Services Tariff
Section 19
2nd Revised Sheet 17
Replacing 1st Revised Sheet 17

ACCESS SERVICES

19. NETWORK MANAGEMENT SERVICES (cont'd)

(RT)

(RT)

Issued: January 3, 2003

Effective: February 2, 2003

By CINDY BRINKLEY, President-Missouri
Southwestern Bell Telephone, L.P., d/b/a SBC Missouri
St. Louis, Missouri

No supplement to this tariff will be issued except for the purpose of canceling this tariff.

Access Services Tariff
Section 19
1st Revised Sheet 17
Replacing Original Sheet 17

ACCESS SERVICES

RECEIVED

19. NETWORK MANAGEMENT SERVICES-(Continued)

JAN 10 1997

19.2 Transport Resource Management (TRM) Service-(Continued)

19.2.4 Rate Regulations-(Continued)

**MISSOURI
Public Service Commission**

B. Nonrecurring Charges

Nonrecurring Charges for Service Arrangements, Service Interfaces and Optional Features will be applied on a First and Additional basis. The First Nonrecurring Charge will be applied to the first service ordered on an access order; the Additional Nonrecurring Charge will be applied to additional services ordered on the same access order. In order to receive the benefits associated with ordering multiple services, the following criteria must be met:

- Same Access Service Order
- Same Application for Service Date
- Same Due Date
- Identical Services
- Same Billing Account Number (BAN)
- Same TRM Service Hub.

Nonrecurring Charges, as set forth in Section 7, are also applicable when existing access services must be reterminated at a TRM Service Hub.

C. Rate Application

(RT)

When TRM is used in conjunction with Voice Grade, MegaLink Data or High Capacity services, the appropriate regulations, rates and charges as set forth in Section 7 will apply in addition to charges as set forth in 19.2.5:

- One Channel Termination (CT) applies between the customer designated premises and serving wire center.
- Channel Mileage, if applicable, applies between the serving wire center and the Telephone Company TRM Hub, or between the CO Multiplexing Hub and the TRM Service Hub, or between the NRS HUB and the TRM Service Hub, or between two TRM Service Hubs.

CANCELLED

FILED

FEB 02 2003

FEB 10 1997

by *andrs17*
Public Service Commission
MISSOURI

MO.PUBLICSERVICECOMM

Issued: JAN 10 1997

Effective: FEB 10 1997

By KAREN E. JENNINGS, President-Missouri
Southwestern Bell Telephone
St. Louis, Missouri

No supplement to this tariff will be issued except for the purpose of canceling this tariff.

Access Services Tariff
Section 19
Original Sheet 17

ACCESS SERVICES

RECEIVED

19. NETWORK MANAGEMENT SERVICES-(Continued)

AUG 26 1994

19.2 Transport Resource Management (TRM) Service-(Continued)

MO. PUBLIC SERVICE COMM.

19.2.4 Rate Regulations-(Continued)

B. Nonrecurring Charges

Nonrecurring Charges for Service Arrangements, Service Interfaces and Optional Features will be applied on a First and Additional basis. The First Nonrecurring Charge will be applied to the first service ordered on an access order; the Additional Nonrecurring Charge will be applied to additional services ordered on the same access order. In order to receive the benefits associated with ordering multiple services, the following criteria must be met:

~~CANCELLED~~

- Same Access Service Order
- Same Application for Service Date
- Same Due Date
- Identical Services
- Same Billing Account Number (BAN)
- Same TRM Service Hub.

FEB 10 1997
BY 1st R.S. # 17
Public Service Commission
MISSOURI

Nonrecurring Charges, as set forth in Section 7, are also applicable when existing access services must be reterminated at a TRM Service Hub.

C. Rate Application

When TRM is used in conjunction with Voice Grade, MegaLink Data, Business Video I, Business Video II or High Capacity services, the appropriate regulations, rates and charges as set forth in Section 7 will apply in addition to charges as set forth in 19.2.5:

- One Channel Termination (CT) applies between the customer designated premises and serving wire center.
- Channel Mileage, if applicable, applies between the serving wire center and the Telephone Company TRM Hub, or between the CO Multiplexing Hub and the TRM Service Hub, or between the NRS HUB and the TRM Service Hub, or between two TRM Service Hubs.

FILED

SEP 26 1994

Issued: AUG 26 1994

Effective: SEP 26 1994

MISSOURI
Public Service Commission

By M. H. SCHULTEIS, Executive Director-External Affairs
Southwestern Bell Telephone
St. Louis, Missouri

No Supplement to this tariff will be issued except for the purpose of canceling this tariff.

Access Services Tariff
Section 19
1st Revised Sheet 18
Replacing Original Sheet 18

ACCESS SERVICES

19. NETWORK MANAGEMENT SERVICES (cont'd)

(RT)

(RT)

Issued: January 3, 2003

Effective: February 2, 2003

By CINDY BRINKLEY, President-Missouri
Southwestern Bell Telephone, L.P., d/b/a SBC Missouri
St. Louis, Missouri

No supplement to this tariff will be issued except for the purpose of canceling this tariff.

Access Services Tariff
Section 19
Original Sheet 18

RECEIVED

ACCESS SERVICES

AUG 26 1994

19. NETWORK MANAGEMENT SERVICES-(Continued)

19.2 Transport Resource Management (TRM) Service-(Continued) MO. PUBLIC SERVICE COMM.

19.2.4 Rate Regulations-(Continued)

D. Termination of Service

Customers requesting the termination of a Service Arrangement prior to the expiration of the 1 year, 3 year or 5 year fixed service period agreement will be charged as indicated below:

<u>Number of Years in Arrangement</u>	<u>Termination Percentage</u>
1, 3 or 5 years	60%

The termination charge will be calculated as follows:

Service Arrangement	Months	Termination
billed monthly rate	X remaining in	X Percentage.
	Arrangement	

Example: A customer with a 3 year Service Arrangement decides to terminate service after 12 months. The Service Arrangement billed monthly rate is \$1,800.00. The termination charge applied will be as follows:

$\$1,800.00 \times 24 \times .60 = \$25,920.00.$

CANCELLED

FEB 02 2003
by *ISHS/18*
Public Service Commission
MISSOURI

FILED

SEP 26 1994

MISSOURI
Public Service Commission

Issued: AUG 26 1994

Effective: SEP 26 1994

By M. H. SCHULTEIS, Executive Director-External Affairs
Southwestern Bell Telephone
St. Louis, Missouri

No Supplement to this tariff will be issued except for the purpose of canceling this tariff.

Access Services Tariff
Section 19
1st Revised Sheet 19
Replacing Original Sheet 19

ACCESS SERVICES

19. NETWORK MANAGEMENT SERVICES (cont'd)

(RT)

(RT)

Issued: January 3, 2003

Effective: February 2, 2003

By CINDY BRINKLEY, President-Missouri
Southwestern Bell Telephone, L.P., d/b/a SBC Missouri
St. Louis, Missouri

No supplement to this tariff will be issued except for the purpose of canceling this tariff.

Access Services Tariff
Section 19
Original Sheet 19

ACCESS SERVICES

RECEIVED

19. NETWORK MANAGEMENT SERVICES--(Continued)

AUG 26 1994

19.2 Transport Resource Management (TRM) Service--(Continued)

19.2.4 Rate Regulations--(Continued)

MO. PUBLIC SERVICE COMM.

E. Service Configuration

The following diagram depicts a typical TRM Network with its applicable rate elements:

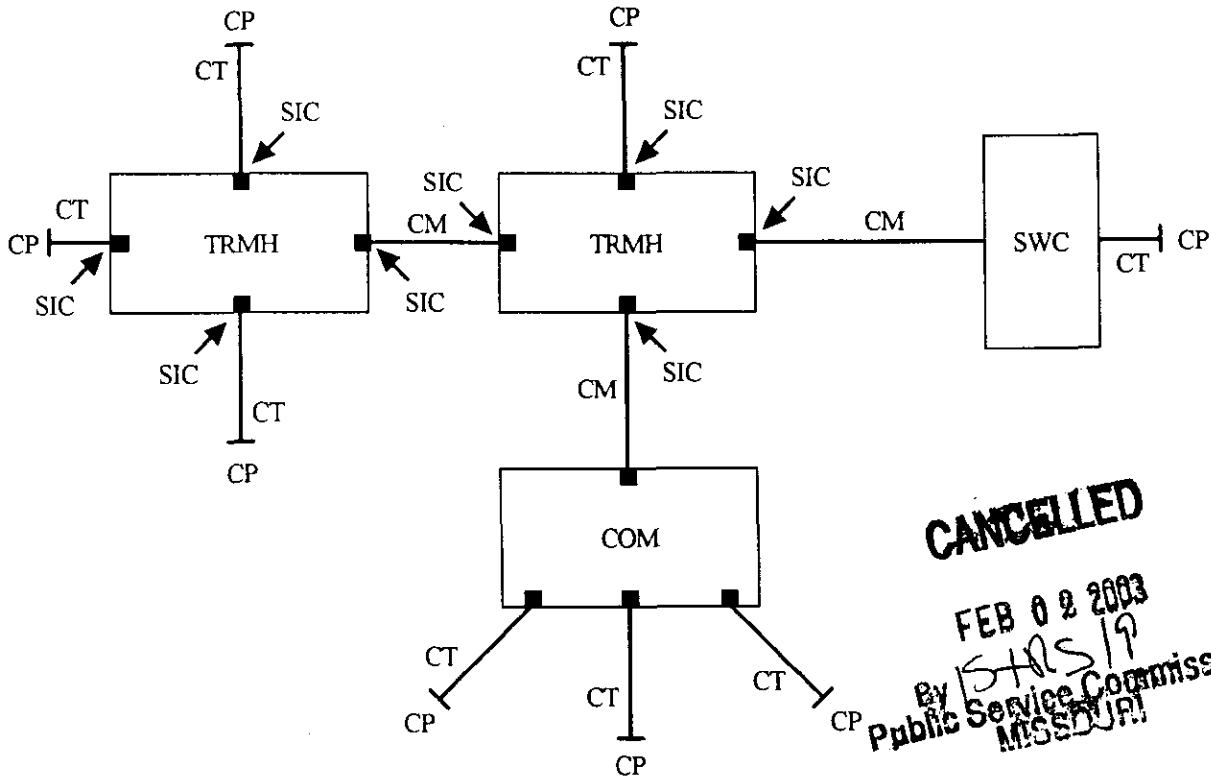

CANCELLED
FEB 02 2003
By *SHS/19*
Public Service Commission
MISSOURI

- CM = Channel Mileage
- COM = Central Office Multiplexing Hub
- CP = Customer Premises
- CT = Channel Termination
- SIC = Service Interface Charge
- SWC = Serving Wire Center
- TRMH = Transport Resource Management Service Hub

FILED

SEP 26 1994

MISSOURI
Public Service Commission

Issued: **AUG 26 1994**

Effective: **SEP 26 1994**

By M. H. SCHULTEIS, Executive Director-External Affairs
Southwestern Bell Telephone
St. Louis, Missouri

No Supplement to this tariff will be issued except for the purpose of canceling this tariff.

Access Services Tariff
Section 19
1st Revised Sheet 20
Replacing Original Sheet 20

ACCESS SERVICES

19. NETWORK MANAGEMENT SERVICES (cont'd)

(RT)

(RT)

Issued: January 3, 2003

Effective: February 2, 2003

By CINDY BRINKLEY, President-Missouri
Southwestern Bell Telephone, L.P., d/b/a SBC Missouri
St. Louis, Missouri

No supplement to this tariff will be issued except for the purpose of canceling this tariff.

Access Services Tariff
Section 19
Original Sheet 20

ACCESS SERVICES

RECEIVED

19. NETWORK MANAGEMENT SERVICES-(Continued)

AUG 26 1994

19.2 Transport Resource Management (TRM) Service-(Continued)

MO. PUBLIC SERVICE COMM.

19.2.5 Rates and Charges

A. Service Arrangement Charges

	Month-to -Month Rate	1 Year Monthly Rate	3 Year Monthly Rate	5 Year Monthly Rate	Nonrecurring Charges	
					1st Arr	Addl Arr
1. Standard Arrangement (BWMSX)	\$1,900.00	\$1,810.00	\$1,650.00	\$1,600.00	\$303.00	\$63.00
2. DS3 Arrangement (BWM3X)	\$2,250.00	\$2,050.00	\$1,950.00	\$1,860.00	\$ 98.00	\$45.00

B. Network Modification Charge (NRBNM)

Per request per access service Nonrecurring Charge
\$4.00

C. Service Interface Charges

	Monthly Rate	Nonrecurring 1st Svc	Nonrecurring Charges
			Addl Svc
1. DS1 Service Interface (BW11X)	\$45.00	\$48.00	\$45.00
2. DS0 Service Interface			
- MegaLink Data (BW10P)	12.00	61.00	53.00
- Voice Grade (BW10V)	12.00	61.00	53.00
3. Network Management Service Interface (BW1NX)	210.00	332.00	271.00

CANCELLED

FEB 02 2003

Missouri Public Service Commission
1500 State Street
St. Louis, MO 63103

FILED

SEP 26 1994

**MISSOURI
Public Service Commission**

Issued: **AUG 26 1994**

Effective: **SEP 26 1994**

By M. H. SCHULTEIS, Executive Director-External Affairs
Southwestern Bell Telephone
St. Louis, Missouri

No Supplement to this tariff will be issued except for the purpose of canceling this tariff.

Access Services Tariff
Section 19
1st Revised Sheet 21
Replacing Original Sheet 21

ACCESS SERVICES

19. NETWORK MANAGEMENT SERVICES (cont'd)

(RT)

(RT)

Issued: January 3, 2003

Effective: February 2, 2003

By CINDY BRINKLEY, President-Missouri
Southwestern Bell Telephone, L.P., d/b/a SBC Missouri
St. Louis, Missouri

No supplement to this tariff will be issued except for the purpose of canceling this tariff.

Access Services Tariff
Section 19
Original Sheet 21

ACCESS SERVICES

RECEIVED

19. NETWORK MANAGEMENT SERVICES--(Continued)

AUG 26 1994

19.2 Transport Resource Management (TRM) Service--(Continued)

19.2.5 Rates and Charges--(Continued)

MO. PUBLIC SERVICE COMM.

	<u>Monthly Rate</u>	<u>Nonrecurring 1st Svc</u>	<u>Charges Addl Svc</u>
D. Optional Features			
1. Subrate Multiplexing (BWFSX)	\$132.00	\$48.00	\$48.00
2. Voice Compression (BWFVX)	96.00	39.00	39.00
3. Voice and Data Bridging (BWFBX)	133.00	51.00	51.00
4. Frame Relay (BWFFX)	215.00	76.00	76.00

CANCELLED

FEB 02 2003

ISTR 21
Public Service Commission
MISSOURI

FILED

SEP 26 1994

MISSOURI
Public Service Commission

Issued: **AUG 26 1994**

Effective: **SEP 26 1994**

By M. H. SCHULTEIS, Executive Director-External Affairs
Southwestern Bell Telephone
St. Louis, Missouri

No Supplement to this tariff will be issued except for the purpose of canceling this tariff.

Access Services Tariff
Section 20
2nd Revised Sheet 1
Replacing 1st Revised Sheet 1

ACCESS SERVICES

20. COMMON CHANNEL SIGNALING/SIGNALING SYSTEM 7 (CCS/SS7)
INTERCONNECTION SERVICE

20.1 General

20.1.1 General Description

Common Channel Signaling/Signaling System 7 (CCS/SS7) Interconnection Service, provides a dedicated two-way signaling path between the customer-designated premises and a Telephone Company interconnecting Signal Transfer Point (STP). The customer's designated premises and the Telephone Company's STP must be in the same LATA. CCS/SS7 Interconnection Service provides interconnection with the Telephone Company's CCS/SS7 network and can be used to access Telephone Company services as they become available and as facilities permit.

CCS/SS7 Interconnection Service utilizes an STP Access Connection, an STP Access Link and an STP Port Termination. The STP Access Connection provides for the DS1 (1.544 Mbps) transmission facility between the serving wire center of the customer designated premises and the Telephone Company hub, where multiplexing from 1.544 Mbps to 56 kbps will occur. The STP Access Link provides for the 56 kbps digital transmission facility between the Telephone Company hub and the Telephone Company STP. The STP Port Termination provides for the physical termination of the customer's 56 kbps circuit into the telephone Company STP, where access to the Telephone Company's CCS/SS7 network will occur.

(AT) This service is competitively classified.

Issued: February 20, 2002

Effective: March 29, 2002

By JAN NEWTON, President-Missouri
Southwestern Bell Telephone, L.P., d/b/a Southwestern Bell Telephone Company
St. Louis, Missouri

No supplement to this tariff will be issued except for the purpose of canceling this tariff.

Access Services Tariff
Section 20
1st Revised Sheet 1
Replacing Original Sheet 1

ACCESS SERVICES

20. COMMON CHANNEL SIGNALING/SIGNALING SYSTEM 7 (CCS/SS7) INTERCONNECTION SERVICE

RECEIVED

20.1 General

MAR 07 1994

(CT) 20.1.1 General Description

**MISSOURI
Public Service Commission**

Common Channel Signaling/Signaling System 7 (CCS/SS7) Interconnection Service, provides a dedicated two-way signaling path between the customer-designated premises and a Telephone Company interconnecting Signal Transfer Point (STP). The customer's designated premises and the Telephone Company's STP must be in the same LATA. CCS/SS7 Interconnection Service provides interconnection with the Telephone Company's CCS/SS7 network and can be used to access Telephone Company services as they become available and as facilities permit.

(AT)

CCS/SS7 Interconnection Service utilizes an STP Access Connection, an STP Access Link and an STP Port Termination. The STP Access Connection provides for the DS1 (1.544 Mbps) transmission facility between the serving wire center of the customer designated premises and the Telephone Company hub, where multiplexing from 1.544 Mbps to 56 kbps will occur. The STP Access Link provides for the 56 kbps digital transmission facility between the Telephone Company hub and the Telephone Company STP. The STP Port Termination provides for the physical termination of the customer's 56 kbps circuit into the telephone Company STP, where access to the Telephone Company's CCS/SS7 network will occur.

(AT)

CANCELLED

MAR 29 2002
John R. S1
**Public Service Commission
MISSOURI**

FILED

APR 7 1994

**MISSOURI
Public Service Commission**

Issued: MAR 07 1994

Effective: APR 07 1994

By M. H. SCHULTEIS, Division Manager-Regulatory & Industry Relations
Southwestern Bell Telephone Company
St. Louis, Missouri

No supplement to this tariff will be issued except for the purpose of canceling this tariff.

Access Services Tariff
Section 20
Original Sheet 1

ACCESS SERVICES

RECEIVED

20. COMMON CHANNEL SIGNALING/SIGNALING SYSTEM 7 (CCS/SS7) INTERCONNECTION SERVICE

MAY 11 1992

20.1 General

MO. PUBLIC SERVICE COMM

20.1.1 Service Description

Common Channel Signaling/Signaling System 7 (CCS/SS7) Interconnection Service, provides a dedicated two-way signaling path between the customer-designated premises and a Telephone Company interconnecting Signal Transfer Point (STP). The customer's designated premises and the Telephone Company's STP must be in the same LATA. CCS/SS7 Interconnection Service provides interconnection with the Telephone Company's CCS/SS7 network and can be used to access Telephone Company services as they become available and as facilities permit.

CANCELLED

APR 7 1994

BY Jet R. S. #1

Public Service Commission
MISSOURI

FILED

NOV 16 1992

MO. PUBLIC SERVICE COMM.

Issued:

MAY 13 1992

Effective:

~~OCT 9 9 1992~~

NOV 16 1992

By A. D. ROBERTSON, Assistant Vice President-External Affairs
Southwestern Bell Telephone Company
St. Louis, Missouri

No Supplement to this tariff will be issued except for the purpose of canceling this tariff.

Access Services Tariff
Section 20
1st Revised Sheet 2
Replacing Original Sheet 2

ACCESS SERVICES

20. COMMON CHANNEL SIGNALING/SIGNALING SYSTEM 7 (CCS/SS7)
INTERCONNECTION SERVICE-(Continued)

20.1 General-(Continued)

20.1.2 Manner of Provisioning

The customer may utilize an existing DS1 (1.544 Mbps) facility for CCS/SS7 Interconnection Service. If the customer does not have existing DS1 facilities available for use with CCS/SS7 Interconnection Service, and does not want to order a DS1 Channel, the Telephone Company will provide an STP Access Connection between

(AT) the serving wire center of the customer-designated premises and the Telephone Company Hub. When a DS1 Channel or an STP Access Connection is utilized by the customer, multiplexing from 1.544 Mbps

(AT) to 56 kbps will occur at the designated Telephone Company Hub. A Customer Signaling Point Code will also be installed at the Telephone Company interconnecting STP. STP locations are set forth

(AT) in the National Exchange Carrier Association, Inc. Tariff F.C.C. No. 4.

One STP Port Termination is required for each 56 kbps access link utilized for CCS/SS7 Interconnection Service and will be installed at

(AT) the Telephone Company interconnecting STP. A customer signaling point code will also be translated at the Telephone Company

(AT) interconnecting STP. STP locations are set forth in the National Exchange Carrier Association, Inc. Tariff F.C.C. No. 4.

(AT) CCS/SS7 Interconnection Service is provisioned in A-Link pairs (multiples of 2) or B/D Link Quads (multiples of 4). Either of two architecture configurations may be used:

A Links connect a customer's Signaling Point with a Telephone Company mated Signaling Transfer Point pair per LATA.

B/D Links connect a customer's mated STP pair to a Telephone Company mated STP pair per LATA.

(AT)

Issued: March 7, 1994

Effective: April 7, 1994

By M. H. SCHULTEIS, Division Manager-Regulatory & Industry Relations
Southwestern Bell Telephone Company
St. Louis, Missouri

No supplement to this tariff will be issued except for the purpose of canceling this tariff.

Access Services Tariff
Section 20
Original Sheet 2

ACCESS SERVICES

20. COMMON CHANNEL SIGNALING/SIGNALING SYSTEM 7 (CCS/SS7) INTERCONNECTION SERVICE-(Continued)

RECEIVED
MAY 11 1992

20.1 General-(Continued)

MO. PUBLIC SERVICE COMM.

20.1.2 Manner of Provisioning

The customer may utilize an existing DS1 (1.544 Mbps) facility for CCS/SS7 Interconnection Service. If the customer does not have existing DS1 facilities available for use with CCS/SS7 Interconnection Service, and does not want to order a DS1 Channel, the Telephone Company will provide an STP Access Connection between the customer-designated premises and the Telephone Company Hub. When a DS1 Channel or an STP Access Connection is utilized by the customer, multiplexing from 1.544 Mbps to 56 kbps will occur at the designated Telephone Company Hub.

One STP Port Termination is required for each 56 kbps access link utilized for CCS/SS7 Interconnection Service and will be installed at the Telephone Company interconnecting STP. STP locations are set forth in the National Exchange Carrier Association, Inc. Tariff F.C.C. No. 4.

CANCELLED

APR 7 1994
BY *1st R.S. #2*
Public Service Commission
MISSOURI

FILED

NOV 16 1992

MO. PUBLIC SERVICE COMM.

Issued: **MAY 13 1992**

Effective: ~~OCT 22 1992~~ **NOV 16 1992**

By A. D. ROBERTSON, Assistant Vice President-External Affairs
Southwestern Bell Telephone Company
St. Louis, Missouri

No Supplement to this tariff will be issued except for the purpose of canceling this tariff.

Access Services Tariff
Section 20
1st Revised Sheet 3
Replacing Original Sheet 3

ACCESS SERVICES

20. COMMON CHANNEL SIGNALING/SIGNALING SYSTEM 7 (CCS/SS7)
INTERCONNECTION SERVICE-(Continued)

20.1 General-(Continued)

20.1.3 Rate Elements

The following Switched Access rate elements apply to CCS/SS7 Interconnection Service:

A. STP Access Connection

The STP Access Connection rate element provides the transmission facilities between the customer-designated premises and the Telephone Company Hub.

The STP Access Connection charges are calculated according to mileage band. There are two rates that may apply per band, i.e., a fixed monthly rate per mileage band and a monthly rate per mile.

A nonrecurring charge also applies per STP Access Connection. This charge applies on a first and additional basis.

B. STP Access Mileage

The STP Access Mileage rate element provides the 56 kbps transmission facilities between a designated Telephone Company Hub and the Telephone Company interconnecting STP.

STP Access Mileage is calculated according to mileage band. There are two rates that apply per band, i.e., a fixed monthly rate per mileage band and a monthly rate per mile.

C. STP Port Termination

The STP Port Termination rate element provides for the termination of the customer's 56 kbps circuit. One STP Port Termination must be installed at the Telephone Company interconnecting STP for each 56 kbps circuit.

There are two charges that apply to the STP Port Termination, i.e., a fixed recurring monthly rate per port termination and a nonrecurring installation charge per port.

(AT) D. Customer Signaling Point Code

|
|
|
(AT) The Customer Signaling Point Code rate element provides for the installation of the customer's CCS network signaling point (address) code. A nonrecurring charge applies per Customer Signaling Point Code.

Issued: March 7, 1994

Effective: April 7, 1994

By M. H. SCHULTEIS, Division Manager-Regulatory & Industry Relations
Southwestern Bell Telephone Company
St. Louis, Missouri

No supplement to this tariff will be issued except for the purpose of canceling this tariff.

ACCESS SERVICES

RECEIVED

MAY 11 1992

20. COMMON CHANNEL SIGNALING/SIGNALING SYSTEM 7 (CCS/SS7) INTERCONNECTION SERVICE-(Continued)

20.1 General-(Continued)

MO. PUBLIC SERVICE COMM.

20.1.3 Rate Elements

The following Switched Access rate elements apply to CCS/SS7 Interconnection Service: **CANCELLED**

A. STP Access Connection

APR 7 1994

The STP Access Connection rate element provides the transmission facilities between the customer-designated premises and the Telephone Company Hub. *for R.S. #3*

The STP Access Connection charges are calculated according to mileage band. There are two rates that may apply per band, i.e., a fixed monthly rate per mileage band and a monthly rate per mile.

A nonrecurring charge also applies per STP Access Connection. This charge applies on a first and additional basis.

B. STP Access Mileage

The STP Access Mileage rate element provides the 56 kbps transmission facilities between a designated Telephone Company Hub and the Telephone Company interconnecting STP.

STP Access Mileage is calculated according to mileage band. There are two rates that apply per band, i.e., a fixed monthly rate per mileage band and a monthly rate per mile.

C. STP Port Termination

The STP Port Termination rate element provides for the termination of the customer's 56 kbps circuit. One STP Port Termination must be installed at the Telephone Company interconnecting STP for each 56 kbps circuit.

There are two charges that apply to the STP Port Termination, i.e., a fixed recurring monthly rate per port termination and a nonrecurring installation charge per port.

FILED

NOV 16 1992

MO. PUBLIC SERVICE COMM.

Issued: **MAY 13 1992**

Effective: ~~007-0-2-1992~~ **NOV 16 1992**

By A. D. ROBERTSON, Assistant Vice President-External Affairs
Southwestern Bell Telephone Company
St. Louis, Missouri

No Supplement to this tariff will be issued except for the purpose of canceling this tariff.

ACCESS SERVICES

20. COMMON CHANNEL SIGNALING/SIGNALING SYSTEM 7 (CCS/SS7)
INTERCONNECTION SERVICE-(Continued)

20.1 General-(Continued)

20.1.4 Ordering Options and Conditions

CCS/SS7 Interconnection Service is ordered under the Access Order provisions set forth in Section 5. The Access Order Charge applicable for Switched Access will apply per Access Order for the installation, addition, change or rearrangement of CCS/SS7 Interconnection Service. Other charges associated with the ordering of CCS/SS7 Interconnection Service are applicable as specified in Section 5.

20.2 Transmission Specifications

The Telephone Company will maintain existing transmission specifications on functioning service configurations installed prior to the effective date of this tariff except that service configurations having performance specifications exceeding the standards listed in this provision will be maintained at performance levels specified in the appropriate Technical Reference Publication.

20.3 Acceptance Testing

At the customer's request, the Telephone Company will, at no additional charge, cooperatively test at the time of installation.

Issued: May 13, 1992

Effective: November 16, 1992

By A. D. ROBERTSON, Assistant Vice President-External Affairs
Southwestern Bell Telephone Company
St. Louis, Missouri

No Supplement to this tariff will be issued except for the purpose of canceling this tariff.

ACCESS SERVICES

20. COMMON CHANNEL SIGNALING/SIGNALING SYSTEM 7 (CCS/SS7) INTERCONNECTION SERVICE-(Continued)

20.4 Obligations of the Telephone Company

In addition to the obligations of the Telephone Company set forth in Section 2, the Telephone Company has certain other obligations pertaining to the provision of CCS/SS7 Interconnection Service. These obligations are as follows:

20.4.1 Network Management

The Telephone Company will administer its network to ensure the provision of acceptable service levels to all telecommunication users of the Telephone Company's network services. The Telephone Company maintains the right to apply protective controls which would generally be applied as a result of occurrences such as failure or overload of Telephone Company or customer facilities, natural disasters, mass calling or national security demands. In the event that the protective controls applied by the Telephone Company result in the complete loss of service by the customer, the customer will be granted a Credit Allowance for Service Interruption as set forth in Section 2.

20.4.2 Provision of Service Performance Data

Subject to availability, end-to-end service performance data available to the Telephone Company through its own service evaluation routines, may be made available to the customer. This data provides information on STP Port availability. This data does not include service performance data which is provided under other tariff sections, e.g., testing service results. If the data is to be provided in other than paper format, the charges for such exchange will be determined on an individual case basis.

Issued: May 13, 1992

Effective: November 16, 1992

By A. D. ROBERTSON, Assistant Vice President-External Affairs
Southwestern Bell Telephone Company
St. Louis, Missouri

No Supplement to this tariff will be issued except for the purpose of canceling this tariff.

ACCESS SERVICES

20. COMMON CHANNEL SIGNALING/SIGNALING SYSTEM 7 (CCS/SS7)
INTERCONNECTION SERVICE-(Continued)

20.5 Obligations of the Customer

In addition to the obligations of the customer set forth in Section 2, the customer has certain other obligations pertaining to the use of CCS/SS7 Interconnection Service. These obligations are as follows:

20.5.1 Forecast Report

The customer shall furnish to the Telephone Company, at the time CCS/SS7 Interconnection is ordered and annually thereafter, an updated three-year forecast of usage for the STP Access Connection, the STP Access Link and the STP Port Termination. The forecast shall include total annual volume and busy hour busy month volume. The Telephone Company will utilize the forecast in its own efforts to project further facility requirements.

Issued: May 13, 1992

Effective: November 16, 1992

By A. D. ROBERTSON, Assistant Vice President-External Affairs
Southwestern Bell Telephone Company
St. Louis, Missouri

No Supplement to this tariff will be issued except for the purpose of canceling this tariff.

ACCESS SERVICES

20. COMMON CHANNEL SIGNALING/SIGNALING SYSTEM 7 (CCS/SS7)
INTERCONNECTION SERVICE-(Continued)

20.6 Rate Regulations

This section contains specific regulations governing the rates and charges that apply for CCS/SS7 Interconnection Service.

20.6.1 Description of Rates and Charges

There are two types of rates and charges which apply to CCS/SS7 Interconnection Service. They are monthly recurring rates and nonrecurring charges. These rates and charges are applied differently to the various rate elements as set forth below. For billing purposes, each month is considered to have 30 days.

A. Monthly Rates

Monthly rates are fixed recurring rates that apply each month, or fraction thereof, that a specific rate element is provided.

B. Nonrecurring Charges

Nonrecurring charges are one-time charges that apply for a specific work activity (i.e., installation of a service or rearrangement of an existing service.)

Charges for the rearrangement of CCS/SS7 Interconnection Service are set forth in Section 6.

Issued: May 13, 1992

Effective: November 16, 1992

By A. D. ROBERTSON, Assistant Vice President-External Affairs
Southwestern Bell Telephone Company
St. Louis, Missouri

No Supplement to this tariff will be issued except for the purpose of canceling this tariff.

Access Services Tariff
Section 20
1st Revised Sheet 8
Replacing Original Sheet 8

ACCESS SERVICES

20. COMMON CHANNEL SIGNALING/SIGNALING SYSTEM 7 (CCS/SS7)
INTERCONNECTION SERVICE-(Continued)

20.6 Rate Regulations-(Continued)

20.6.2 Application of Rates and Charges

STP Access Mileage and the STP Access Connection are Local Transport monthly rated Switched Access Service rate elements are not subject to the usage (i.e., Local Transport, Local Switching and Carrier Common Line) rate categories as set forth in Sections 3 and 6.

(CT) Rates and charges for the STP Access Connection, STP Access Link, STP
(CT) Port Termination and the Customer Signaling Point Code apply as follows:

A. STP Access Connection

A fixed monthly rate applies for each STP Access Connection between the Telephone Company Hub and the customer-designated premises.

A monthly rate per mile applies to each airline mile between the Telephone Company Hub and the Serving Wire Center of the customer-designated premises.

A nonrecurring charge applies for the installation of each STP Access Connection. This charge is applied on a first and additional basis.

(CT) B. STP Access Link

A fixed monthly rate applies, per mileage band, for each 56 kbps access link between the Telephone Company Hub, where multiplexing from DS1 (1.544 Mbps) to a 56 kbps circuit occurs, and the Telephone Company interconnecting STP.

A monthly rate per mile applies to each airline mile between the Telephone Company Hub, where multiplexing from DS1 (1.544 Mbps) to a 56 kbps circuit occurs, and the Telephone Company interconnecting STP.

C. STP Port Termination

A monthly rate applies for each STP Port Termination installed at the Telephone Company interconnecting STP.

A nonrecurring charge applies for the installation of each STP Port Termination at the Telephone Company interconnecting STP.

Issued: March 7, 1994

Effective: April 7, 1994

By M. H. SCHULTEIS, Division Manager-Regulatory & Industry Relations
Southwestern Bell Telephone Company
St. Louis, Missouri

No supplement to this tariff will be issued except for the purpose of canceling this tariff.

Access Services Tariff
Section 20
Original Sheet 8

ACCESS SERVICES

RECEIVED

20. COMMON CHANNEL SIGNALING/SIGNALING SYSTEM 7 (CCS/SS7) INTERCONNECTION SERVICE-(Continued)

MAY 11 1992

20.6 Rate Regulations-(Continued)

MO. PUBLIC SERVICE COMM.

20.6.2 Application of Rates and Charges

STP Access Mileage and the STP Access Connection are Local Transport monthly rated Switched Access Service rate elements are are not subject to the usage (i.e., Local Transport, Local Switching and Carrier Common Line) rate categories as set forth in Sections 3 and 6.

Rates and charges for STP Access Mileage, the STP Access Connection and STP Port Termination apply as follows:

CANCELLED

APR 7 1994

A. STP Access Connection

A fixed monthly rate applies for each STP Access Connection between the Telephone Company Hub and the customer-designated premises.

A monthly rate per mile applies to each airline mile between the Telephone Company Hub and the Serving Wire Center of the customer-designated premises.

A nonrecurring charge applies for the installation of each STP Access Connection. This charge is applied on a first and additional basis.

B. STP Access Mileage

A fixed monthly rate applies, per mileage band, for each 56 kbps access link between the Telephone Company Hub, where multiplexing from DS1 (1.544 Mbps) to a 56 kbps circuit occurs, and the Telephone Company interconnecting STP.

A monthly rate per mile applies to each airline mile between the Telephone Company Hub, where multiplexing from DS1 (1.544 Mbps) to a 56 kbps circuit occurs, and the Telephone Company interconnecting STP.

C. STP Port Termination

A monthly rate applies for each STP Port Termination installed at the Telephone Company interconnecting STP.

A nonrecurring charge applies for the installation of each STP Port Termination at the Telephone Company interconnecting STP.

FILED

NOV 16 1992

MO. PUBLIC SERVICE COMM.

Issued: MAY 13 1992

Effective: ~~OCT 9 1992~~ NOV 16 1992

By A. D. ROBERTSON, Assistant Vice President-External Affairs
Southwestern Bell Telephone Company
St. Louis, Missouri

No Supplement to this tariff will be issued except for the purpose of canceling this tariff.

ACCESS SERVICES

20. COMMON CHANNEL SIGNALING/SIGNALING SYSTEM 7 (CCS/SS7)
INTERCONNECTION SERVICE-(Continued)

20.6 Rate Regulations-(Continued)

20.6.2 Application of Rates and Charges-(Continued)

(AT) D. Customer Signaling Point Code

|
|
|
(AT) A nonrecurring charge applies for the installation of each Customer Signaling Point Code installed at the Telephone Company interconnecting STP.

Issued: March 7, 1994

Effective: April 7, 1994

By M. H. SCHULTEIS, Division Manager-Regulatory & Industry Relations
Southwestern Bell Telephone Company
St. Louis, Missouri

No Supplement to this tariff will be issued except for the purpose of canceling this tariff.

ACCESS SERVICES

20. COMMON CHANNEL SIGNALING/SIGNALING SYSTEM 7 (CCS/SS7) INTERCONNECTION SERVICE-(Continued)

20.6 Rate Regulations-(Continued)

20.6.3 Minimum Period

CCS/SS7 Interconnection Service is provided for a minimum period of one month. When service is disconnected prior to the expiration of the minimum period, monthly charges are applicable for the balance of the minimum period. If service is disconnected after the minimum period, monthly charges will be based on the actual number of days the service is furnished, as set forth following. For the purpose of administering this regulation, with respect to the determination of charges for a fractional part of a month, every month is considered to have 30 days.

20.6.4 Moves

The regulations for moves and application of charges are set forth in Section 6.

20.6.5 Mileage Measurement

The mileage to be used to determine the monthly rate for the STP Access Connection and the STP Access Mileage is calculated on the airline distance between the locations involved, i.e., the Telephone Company Hub and the customer-designated premises, or the Telephone Company Hub and the Telephone Company interconnecting STP.

Mileage is shown in Paragraph 20.7, in terms of mileage bands. To determine the rate to be billed, first compute the mileage using the V&H coordinates method, as set forth in the National Exchange Carrier Association, Inc. Tariff F.C.C. No. 4, then find the band into which the computed mileage falls and apply the rate shown for that band. When the calculation results in a fraction of a mile, always round up to the next whole mile before determining the mileage band and applying the rates.

Issued: May 13, 1992

Effective: November 16, 1992

By A. D. ROBERTSON, Assistant Vice President-External Affairs
Southwestern Bell Telephone Company
St. Louis, Missouri

No Supplement to this tariff will be issued except for the purpose of canceling this tariff.

Access Services Tariff
Section 20
1st Revised Sheet 10
Replacing Original Sheet 10

ACCESS SERVICES

20. COMMON CHANNEL SIGNALING/SIGNALING SYSTEM 7 (CCS/SS7)
INTERCONNECTION SERVICE-(Continued)

20.7 Rates and Charges

A. <u>STP Access Connection</u>	<u>USOC</u>	<u>Monthly Rate</u>	
		<u>Fixed</u>	<u>Per Mile</u>
<u>Mileage Bands</u>			
0	CCAX8	\$340.54	---
Over 0 to 4	CCAX8	403.73	\$26.45
Over 4 to 8	CCAX8	403.73	26.45
Over 8 to 25	CCAX8	403.73	26.45
Over 50	CCAX8	403.73	26.45

	<u>USOC</u>	<u>Nonrecurring Charge</u>	
		<u>First</u>	<u>Additional</u>
Per STP Access Connection	NRBSB	\$569.00	\$368.00

(CT) (RT)	B. <u>STP Access Link</u>	<u>USOC</u>	<u>Monthly Rate</u>	
			<u>Fixed</u>	<u>Per Mile</u>

<u>Mileage Bands</u>			
0	1J5FX	---	---
Over 0 to 4	1J5FX	\$100.16	\$.91
Over 4 to 8	1J5FX	\$100.16	.91
Over 8 to 25	1J5FX	\$100.16	.91
Over 25 to 50	1J5FX	\$100.16	.91
Over 50	1J5FX	\$100.16	.91

C. <u>STP Port Termination</u>	<u>USOC</u>	<u>Monthly Rate</u>	<u>Nonrecurring Charge</u>
Per Port Termination	PT8SX	\$318.87	\$214.00

(AT)	D. <u>Customer Signaling Point Code</u>	NRBSF	NA	(NR)	\$ 41.00
------	---	-------	----	------	----------

Issued: March 7, 1994

Effective: April 7, 1994

By M. H. SCHULTEIS, Division Manager-Regulatory & Industry Relations
Southwestern Bell Telephone Company
St. Louis, Missouri

No supplement to this tariff will be issued except for the purpose of canceling this tariff.

Access Services Tariff
Section 20
Original Sheet 10

ACCESS SERVICES

RECEIVED

20. COMMON CHANNEL SIGNALING/SIGNALING SYSTEM 7 (CCS/SS7) INTERCONNECTION SERVICE--(Continued)

MAY 11 1992

20.7 Rates and Charges

MO. PUBLIC SERVICE COMM.

A. <u>STP Access Connection</u>	USOC	Monthly Rate	
		Fixed	Per Mile
<u>Mileage Bands</u>			
0	CCAX8 (NR)	\$340.54	---
Over 0 to 4	CCAX8	403.73	(NR)\$26.45
Over 4 to 8	CCAX8	403.73	26.45
Over 8 to 25	CCAX8	403.73	26.45
Over 25 to 50	CCAX8	403.73	26.45
Over 50	CCAX8 (NR)	403.73	(NR) 26.45
		<u>Nonrecurring Charge</u>	
	USOC	First	Additional
Per STP Access Connection	NRBSB (NR)	\$569.00	(NR)\$368.00

CANCELLED

B. <u>STP Access Mileage</u>	USOC	Monthly Rate	
		Fixed	Per Mile
56 kbps Access Link			
<u>Mileage Bands</u>			
Over 0 to 4	1J5FX	(NR)\$100.16	(NR)\$.91
Over 4 to 8	1J5FX	100.16	.91
Over 8 to 25	1J5FX	100.16	.91
Over 25 to 50	1J5FX	100.16	.91
Over 50	1J5FX	(NR) 100.16	(NR) .91
		Monthly	Nonrecurring
C. <u>STP Port Termination</u>	USOC	Rate	Charge
Per Port Termination	PT8SX (NR)	\$318.87	(NR)\$214.00

APR 7 1994
BY J.R.S. #10
Public Service Commission
MISSOURI

FILED

NOV 16 1992

Issued: **MAY 13 1992**

Effective: ~~NOV 16 1992~~ MO. PUBLIC SERVICE COMM.
NOV 16 1992

By A. D. ROBERTSON, Assistant Vice President-External Affairs
Southwestern Bell Telephone Company
St. Louis, Missouri

No Supplement to this tariff will be issued except for the purpose of canceling this tariff.

Access Services Tariff
Section 21
1st Revised Sheet 1
Replacing Original Sheet 1

ACCESS SERVICES

21. LINE INFORMATION DATA BASE (LIDB) VALIDATION SERVICE

21.1 General Description

Line Information Data Base (LIDB) Validation Service provides the customer the ability to query billing validation data contained in the Telephone Company's LIDB. Access to the Telephone Company's LIDB provides customers with potential toll fraud detection by validating calling card and toll billing exception data and performing public telephone checks.

The Telephone Company's LIDB is accessed through the Telephone Company's Common Channel Signaling/Signaling System 7 (CCS/SS7) Interconnection Service which utilizes American National Standards Institute (ANSI) signaling protocol. LIDB Validation Service customers must arrange for the Telephone Company's CCS/SS7 Interconnection Service, as specified in Section 20, for themselves or through another CCS/SS7 signaling transport service provider.

There is one rate category, LIDB Query, that applies to LIDB Validation Service. The LIDB Query rate category consists of two rate elements; LIDB Query Transport and LIDB Validation Query. The LIDB Query Transport provides for the transport of the LIDB query from the Signaling Transfer Points (STPs) to the Service Control Point (SCP) and back. The LIDB Validation Query provides for the actual validation of the LIDB information. In addition, other service specific charges and nonrecurring charges may apply as specified in Section 6, Paragraphs 6.7 and 6.8.

(AT) This service is competitively classified.

Issued: February 20, 2002

Effective: March 29, 2002

By JAN NEWTON, President-Missouri
Southwestern Bell Telephone, L.P., d/b/a Southwestern Bell Telephone Company
St. Louis, Missouri

No supplement to this tariff will be issued except for the purpose of canceling this tariff.

Access Services Tariff
Section 21
Original Sheet 1

RECEIVED

ACCESS SERVICES

AUG 18 1993

21. LINE INFORMATION DATA BASE (LIDB) VALIDATION SERVICE

**MISSOURI
Public Service Commission**

21.1 General Description

Line Information Data Base (LIDB) Validation Service provides the customer the ability to query billing validation data contained in the Telephone Company's LIDB. Access to the Telephone Company's LIDB provides customers with potential toll fraud detection by validating calling card and toll billing exception data and performing public telephone checks. This service is a non-competitive service.

The Telephone Company's LIDB is accessed through the Telephone Company's Common Channel Signaling/Signaling System 7 (CCS/SS7) Interconnection Service which utilizes American National Standards Institute (ANSI) signaling protocol. LIDB Validation Service customers must arrange for the Telephone Company's CCS/SS7 Interconnection Service, as specified in Section 20, for themselves or through another CCS/SS7 signaling transport service provider.

There is one rate category, LIDB Query, that applies to LIDB Validation Service. The LIDB Query rate category consists of two rate elements; LIDB Query Transport and LIDB Validation Query. The LIDB Query Transport provides for the transport of the LIDB query from the Signaling Transfer Points (STPs) to the Service Control Point (SCP) and back. The LIDB Validation Query provides for the actual validation of the LIDB information. In addition, other service specific charges and nonrecurring charges may apply as specified in Section 6, Paragraphs 6.7 and 6.8.

CANCELLED

MAR 29 2002

by *LSR*
Public Service Commission
MISSOURI

FILED

SEP 20 1993

**MISSOURI
Public Service Commission**

Issued: **AUG 18 1993**

Effective: **SEP 20 1993**

By A. D. ROBERTSON, Assistant Vice President-External Affairs
Southwestern Bell Telephone Company
St. Louis, Missouri

No Supplement to this tariff will be issued except for the purpose of canceling this tariff.

ACCESS SERVICES

21. LINE INFORMATION DATA BASE (LIDB) VALIDATION SERVICE-(Continued)

21.2 Service Description

LIDB Validation Service is provided by the Telephone Company to its customers in support of alternate billing services. LIDB Validation Service provides access to billing validation data which resides in the Telephone Company data base for use with alternate billing services. Alternate billing services allow customers' end users the ability to bill calls to an account not necessarily associated with the originating line. LIDB Validation Service supports alternate billing services such as Calling Card, Collect Calls, and Third Number Billing.

Customers participating in LIDB Validation Service, for purposes of obtaining billing validation data that resides in the Telephone Company data base, originate queries to the LIDB from an Operator Services System (OSS) identified by an originating point code (OPC). The LIDB query is routed through one of two Telephone Company interconnecting STPs, as designated by the Telephone Company, to the Telephone Company Regional SCP where the LIDB resides. The requested billing validation data, in the form of signaling information, is passed back via either one of the two Telephone Company interconnecting STPs to the customer's designated OSS where the LIDB query was originated. The STPs locations are provided in the National Exchange Carriers Association, Inc. Tariff F.C.C. No. 4.

The Telephone Company LIDB will receive and respond to all Calling Card Service and Billed Number Screening queries, including the Telephone Company's queries. These procedures will be applied uniformly to all users of the Telephone Company's LIDB Validation Service.

LIDB Validation Service will provide the following functions on a per query basis:

- Validation of a telecommunications calling card account number stored in LIDB.
- Determination of whether the billed line has decided in advance to reject certain calls billed as collect or to a third number.
- Determination of billed line as a public (including those classified as semi-public) or nonworking telephone number.

Issued: August 18, 1993

Effective: September 20, 1993

By A. D. ROBERTSON, Assistant Vice President-External Affairs
Southwestern Bell Telephone Company
St. Louis, Missouri

No Supplement to this tariff will be issued except for the purpose of canceling this tariff.

ACCESS SERVICES

21. LINE INFORMATION DATA BASE (LIDB) VALIDATION SERVICE-(Continued)

21.3 Service Provisioning

21.3.1 Manner of Provisioning

- A. All access to the Telephone Company's LIDB will occur through two Telephone Company interconnecting STPs as designated by the Telephone Company. The Telephone Company will provide customer interconnection to the Telephone Company interconnecting STPs through its CCS/SS7 Interconnection Service provided in Section 20. LIDB Validation Service customers must arrange for the Telephone Company's CCS/SS7 Interconnection Service for themselves or through another CCS/SS7 signaling transport service provider.
- B. LIDB Validation Service is ordered under the provisions specified in Section 5. Also included in that section, are other charges which may be associated with ordering LIDB Validation Service (e.g., Service Date Change Charge).

21.3.2 Limitations

Unless expressly authorized in writing by the customer and the Telephone Company, LIDB Validation Service is not to be used for purposes other than those LIDB functions described in Section 21, Paragraph 21.2, preceding. LIDB Validation Service is used for those functions only on a call-by-call basis or for limited purpose of validating billing information by a Billing Clearing House. Data accessed on LIDB may not be stored elsewhere for future use.

Proprietary information residing in the Telephone Company LIDB is protected from unauthorized access and may not be stored in a customer's data base for any reason. All information related to alternate billing services is proprietary. Examples of proprietary information are as follows:

- Billed (Line/Regional Accounting Office (RAO)) Number (resides in the Telephone Company LIDB)
- PIN Number(s) (resides in the Telephone Company LIDB)
 - Billed Number Screening (BNS) indicators (resides in the Telephone Company LIDB)
- Class of Service (resides in the Telephone Company LIDB)
- Reports on LIDB usage
- Information related to billing for LIDB usage
- LIDB usage statistics

Issued: August 18, 1993

Effective: September 20, 1993

By A. D. ROBERTSON, Assistant Vice President-External Affairs
Southwestern Bell Telephone Company
St. Louis, Missouri

No Supplement to this tariff will be issued except for the purpose of canceling this tariff.

ACCESS SERVICES

21. LINE INFORMATION DATA BASE (LIDB) VALIDATION SERVICE-(Continued)

21.3 Service Provisioning-(Continued)

21.3.3 LIDB Data Specifications

The Telephone Company's LIDB will contain a record for every working line number and Billed Number Group. Other exchange carriers who may store their data in the Telephone Company LIDB are requested to provide this data as well.

The Telephone Company will update the LIDB information; e.g., add, delete, and modify customer accounts as customers move, become delinquent on their account, or order new service, on a daily basis.

The Telephone Company has procedures in place to deactivate billing validation data in the event that it is being used fraudulently. Calling cards identified or suspected of being fraudulently used will be updated 7 days a week, 21 hours a day.

21.3.4 Provision Against Fraudulent Use of Service

End user information, pertinent to the investigation, may be shared with LIDB Validation Service customers when validation queries for the specific customer reaches the Telephone Company established fraud threshold level. This fraud threshold level will be applied uniformly to all customers.

Issued: August 18, 1993

Effective: September 20, 1993

By A. D. ROBERTSON, Assistant Vice President-External Affairs
Southwestern Bell Telephone Company
St. Louis, Missouri

No Supplement to this tariff will be issued except for the purpose of canceling this tariff.

ACCESS SERVICES

21. LINE INFORMATION DATA BASE (LIDB) VALIDATION SERVICE-(Continued)

21.3 Service Provisioning-(Continued)

21.3.5 Provision of Billing Information

When a LIDB query is received at the Telephone Company's SCP, a search is performed for the requested validation data. The Telephone Company SCP formulates a response and tallies the LIDB query for billing.

The LIDB queries are accumulated and records are generated identifying the number of queries routed to and from the SCP and processed by the OPC of the customer's OSS location. This information is delivered to the accounting office via tape or by teleprocessing for processing and billing. The query charges will be accumulated per OPC and billed to the LIDB Validation Service customer each month.

The Telephone Company will provide sufficient information with the bill to enable the customer to determine how the billed amount was calculated. Other reports may be provided as mutually agreed upon. Such agreements may involve additional charges or conditions which will be filed on an individual case basis as specified in Section 12.

21.3.6 Testing

The Telephone Company will perform testing of the LIDB Validation Service in conjunction with CCS/SS7 Interconnection Service.

21.3.7 CCS/SS7 Network Performance

The Telephone Company supports the performance standards as defined in Section 7 of TR-TSV-000905. The overall end-to-end CCS/SS7 network objective is less than ten minutes unavailability per year from any Signal Point (SP) to any other SP. The performance objective for any single SP, including an SCP, is less than three minutes unavailability per year. The combined link set from the SCP to the STP has a performance objective of less than two minutes unavailability per year.

Issued: August 18, 1993

Effective: September 20, 1993

By A. D. ROBERTSON, Assistant Vice President-External Affairs
Southwestern Bell Telephone Company
St. Louis, Missouri

No Supplement to this tariff will be issued except for the purpose of canceling this tariff.

ACCESS SERVICES

21. LINE INFORMATION DATA BASE (LIDB) VALIDATION SERVICE-(Continued)

21.3 Service Provisioning-(Continued)

21.3.8 LIDB Validation System Performance

LIDB Validation Service system downtime will be less than twelve hours per year. The LIDB validation system is capable of processing up to 100 queries per second. The response time for a query, from switch transmission to reception, should not exceed one second for 99 percent of all queries.

21.3.9 LIDB System Management

The Telephone Company will administer its LIDB to ensure the provision of acceptable service levels to all customers of the Telephone Company's LIDB Validation Service. During periods of LIDB Validation Service system congestion, an automatic call gapping procedure will be utilized to control such congestion. The automatic call gapping procedure will tell the switch the gap (how long the switch should wait before sending another query) and the duration (how long the switch should continue to perform gapping). For example, during an overload condition, the automatic call gapping procedure will tell the LIDB when to begin to drop one out of three of the queries received. This call gapping procedure will be applied uniformly to all users of the Telephone Company's LIDB Validation Service.

The Telephone Company maintains the right to invoke manual intervention of the automatic call gapping procedure to preserve the integrity of the network.

Issued: August 18, 1993

Effective: September 20, 1993

By A. D. ROBERTSON, Assistant Vice President-External Affairs
Southwestern Bell Telephone Company
St. Louis, Missouri

No Supplement to this tariff will be issued except for the purpose of canceling this tariff.

ACCESS SERVICES

21. LINE INFORMATION DATA BASE (LIDB) VALIDATION SERVICE-(Continued)

21.4 Rate Regulations

This section contains the specific regulations governing the rates and charges that apply for LIDB Validation Service.

There are two types of rates and charges which apply to LIDB Validation Service. These are usage rates and nonrecurring charges.

Specific rates and charges are set forth in Section 21, Paragraph, 21.5, following. Jurisdictional report requirements are set forth in Section 2, Paragraph 2.3.13, A.

21.4.1 Rate Elements

The following rate elements apply to LIDB Validation Service:

- LIDB Query Transport (described in (A) following)
- LIDB Validation Query (described in (B) following)

A. LIDB Query Transport

The LIDB Query Transport rate element provides for the routing of the LIDB query through one of two Telephone Company interconnecting STPs, as designated by the Telephone Company, to the Telephone Company Regional SCP where the LIDB resides, and back. The SCP and STPs locations are provided in the National Exchange Carriers Association, Inc. Tariff F.C.C. No 4.

B. LIDB Validation Query

The LIDB Validation Query rate element provides for the validation of calling card and toll billing exception data and performance of public telephone checks; i.e., determining if a billed line is a public (including those classified as semi- public) telephone number. For these validation purposes, LIDB Validation Service customers will query the LIDB located in the Telephone Company SCP via the Telephone Company CCS/SS7 network. The LIDB will respond with a verification signal message back to the LIDB Validation Service customer via the Telephone Company CCS/SS7 network.

Issued: August 18, 1993

Effective: September 20, 1993

By A. D. ROBERTSON, Assistant Vice President-External Affairs
Southwestern Bell Telephone Company
St. Louis, Missouri

No Supplement to this tariff will be issued except for the purpose of canceling this tariff.

ACCESS SERVICES

21. LINE INFORMATION DATA BASE (LIDB) VALIDATION SERVICE-(Continued)

21.4 Rate Regulations-(Continued)

21.4.2 Nonrecurring Charges

Nonrecurring charges are one-time charges that apply for a specific work activity (i.e., installation or change to an existing service). Nonrecurring charges are applicable for the establishment of LIDB Validation Service and service rearrangements. In addition, an Access Order Charge may be applicable as specified in Section 5, Paragraph 5.2.

A. Nonrecurring Charge for Establishment of Service

A nonrecurring charge applies for each request for establishment or change of existing LIDB Validation Service. The LIDB Validation Service Establishment Charge applies per OPC per request.

The nonrecurring charge for the establishment of LIDB Validation Service is set forth in Section 21, Paragraph 21.5, following.

B. Nonrecurring Charges for Service Rearrangements

Service Rearrangements are changes to existing services which do not result in changes to previously established OPCs.

Changes in previously established OPCs are treated as a discontinuance of the existing service and establishment of a new service and all applicable nonrecurring charges will apply.

Certain service rearrangements which are administrative in nature as specified in Section 6, Paragraph 6.7 will be made without charge except as noted. Provisions for service rearrangements for which nonrecurring charges will apply are also set forth in Section 6, Paragraph 6.7.

Nonrecurring charges specified in Section 6, Paragraph 6.8 will apply on a per service order basis.

Issued: August 18, 1993

Effective: September 20, 1993

By A. D. ROBERTSON, Assistant Vice President-External Affairs
Southwestern Bell Telephone Company
St. Louis, Missouri

No Supplement to this tariff will be issued except for the purpose of canceling this tariff.

ACCESS SERVICES

21. LINE INFORMATION DATA BASE (LIDB) VALIDATION SERVICE-(Continued)

21.4 Rate Regulations-(Continued)

21.4.3 Usage Rates

Usage rates are rates that apply on a per unit basis, e.g., per query, when a specific rate element is used. Usage charges are accumulated over a monthly period. For billing purposes, each month is considered to have thirty (30) days.

A. LIDB Query Transport

A LIDB Query Transport usage rate applies to each LIDB query that is routed through one of two Telephone Company's interconnecting STPs to the Telephone Company's Regional SCP where the LIDB resides and back. LIDB Query Transport charges are accumulated for each LIDB query and billed to the customer on a monthly basis.

B. LIDB Validation Query

A LIDB Validation Query usage rate applies to each LIDB query received at the Telephone Company's SCP. Query charges are accumulated for each OPC and billed to the customer on a monthly basis.

21.5 Rates and Charges

21.5.1 LIDB Query

Rate Per Query

A. Per LIDB Query Transport \$.0045

B. Per LIDB Validation Query0260

- Billed Number Screening

- Calling Card Count

21.5.2 Service Establishment Charge

Nonrecurring Charge

Per Originating Point Code (OPC)
(NRBLA) \$ 11.00

Issued: August 18, 1993

Effective: September 20, 1993

By A. D. ROBERTSON, Assistant Vice President-External Affairs
Southwestern Bell Telephone Company
St. Louis, Missouri

No Supplement to this tariff will be issued except for the purpose of canceling this tariff.

ACCESS SERVICES

22. COIN SERVICES

22.1 General Description

This section provides rules and regulations pertaining to equal access for handling 1+ interLATA sent-paid traffic from the Telephone Company's public pay telephones.

The Telephone Company will provide, in conjunction with Switched Access Service as set forth in Section 6 of this tariff, originating communications from its public pay telephone stations where end users pay the appropriate charges by inserting coins into the coin station equipment (i.e., sent-paid).

Easy Access Dialing from these coin stations will be provided as set forth in Section 13.

22.2 Service Description

22.2.1 1+ InterLATA Routing

1+ interLATA sent-paid access provides the customer with three options for the routing of interLATA 1+ sent-paid calls. The customer is solely responsible for all 0+ and 1+ interLATA calls originating from the Telephone Company pay telephone station when it utilizes either Option (1) or (2).

- Option 1: To have both 0+ and 1+ interLATA calls directly routed to the customer (i.e., the presubscribed Interexchange Carrier).
- Option 2: To receive the 0+ interLATA calls directly and select one secondary service provider per LATA to receive the 1+ interLATA sent-paid traffic. The Telephone Company must receive written authorization from the customer prior to initiating such routing.
- Option 3: To receive the 0+ interLATA calls directly and continue to default the 1+ interLATA sent-paid calls. This default option will expire when the default carrier ceases to accept such traffic or when the provider is able to handle traffic as set forth in either Option 1 or 2 preceding, whichever comes first.

Issued: June 24, 1994

Effective: August 17, 1994

By M. H. SCHULTEIS, Executive Director-External Affairs
Southwestern Bell Telephone
St. Louis, Missouri

No supplement to this tariff will be issued except for the purpose of canceling this tariff.

Access Services Tariff
Section 22
1st Revised Sheet 2
Replacing Original Sheet 2

ACCESS SERVICES

22. COIN SERVICES-(Continued)

22.2 Service Description

22.2.1 1+ InterLATA Routing-(Continued)

Option 3: Default carrier denotes the provider of MTS and WATS which will provide for interLATA originating sent-paid coin calls from the Telephone Company's public pay telephones until the presubscribed "0+" carrier assumes this responsibility.

(CT) 22.2.2 101XXXX Routing

(CT) When the customer participates in handling 1+ interLATA sent-paid calls in an equal access end office (EAEO), the Telephone Company will route 101XXXX 1+ interLATA sent-paid traffic as set forth in paragraph 22.2.1.

(CT) When the customer does not participate in the handling of such calls, the Telephone Company will route such 101XXXX calls in accordance with the customer's routing instructions.

22.3 Service Provisioning

22.3.1 Call Set Up Signaling

The Telephone Company will provide, where available, two types of call set up signaling from its pay telephones.

- A. Modified Operator Services Signaling (MOSS), as described in Bellcore's Operator Service System Generic Requirements (OSSGR), Document No. TR-NWT-001-144.
- B. Exchange Access Operator Services Signaling (EAOSS), as described in Bellcore's LATA Switching System Generic Requirements (LSSGR), Document No. TR-NWT-000-692.

22.3.2 Equal Access End Office (EAEO) Provisioning

The Telephone Company will provide 1+ interLATA sent-paid access from EAEOs to the customer's Point of Presence (POP) or its designated secondary service provider's POP via one of the following methods:

- A. Via direct routed trunks from the EAEO. The customer will be required to order Operator Trunk Functionality with coin control signaling (i.e., In Band or Expanded In Band)

Issued: September 21, 1998

Effective: October 21, 1998

By PRISCILLA HILL-ARDOIN, President-Missouri
Southwestern Bell Telephone Company
St. Louis, Missouri

No supplement to this tariff will be issued except for the purpose of canceling this tariff.

Access Services Tariff
Section 22
Original Sheet 2

ACCESS SERVICES

RECEIVED

22. COIN SERVICES-(Continued)

JUN 23 1994

22.2 Service Description

**MISSOURI
Public Service Commission**

22.2.1 1+ InterLATA Routing-(Continued)

Option 3: Default carrier denotes the provider of MTS and WATS which will provide for interLATA originating sent-paid coin calls from the Telephone Company's public pay telephones until the presubscribed "0+" carrier assumes this responsibility.

22.2.2 10XXX Routing

When the customer participates in handling 1+ interLATA sent-paid calls in an equal access end office (EAE0), the Telephone Company will route 10XXX 1+ interLATA sent-paid traffic as set forth in paragraph 22.2.1.

When the customer does not participate in the handling of such calls, the Telephone Company will route such 10XXX calls in accordance with the customer's routing instructions.

CANCELLED

22.3 Service Provisioning

22.3.1 Call Set Up Signaling

The Telephone Company will provide, where available, set up signaling from its pay telephones.

**OCT 21 1998
By ISFRS#2
Public Service Commission
MISSOURI**

A. Modified Operator Services Signaling (MOSS), as described in Bellcore's Operator Service System Generic Requirements (OSSGR), Document No. TR-NWT-001-144.

B. Exchange Access Operator Services Signaling (EAOSS), as described in Bellcore's LATA Switching System Generic Requirements (LSSGR), Document No. TR-NWT-000-692.

22.3.2 Equal Access End Office (EAE0) Provisioning

The Telephone Company will provide 1+ interLATA sent-paid access from EAE0s to the customer's Point of Presence (POP) or its designated secondary service provider's POP via one of the following methods:

A. Via direct routed trunks from the EAE0. The customer will be required to order Operator Trunk Functionality with coin control signaling (i.e., In Band or Expanded In Band)

Issued:

JUN 24 1994

By M. H. SCHULTEIS, Executive Director-External Affairs
Southwestern Bell Telephone
St. Louis, Missouri

AUG 17 1994

Effective:

~~JUN 24 1994~~

AUG 17 1994

FILED

MO. PUBLIC SERVICE COMM.

No Supplement to this tariff will be issued except for the purpose of canceling this tariff.

ACCESS SERVICES

22. COIN SERVICES-(Continued)

22.3 Service Provisioning-(Continued)

22.3.2 Equal Access End Office (EAEO) Provisioning-(Continued)

If the EAEO is equipped with MOSS functionality, only MOSS will be provided.

If the EAEO is equipped with EAOSS functionality, either MOSS or EAOSS can be provided at the customer's option.

B. Via the Traffic Operator Position System (TOPS) tandems.

When ordering MOSS between a TOPS tandem and the customer's POP, the customer must order a separate and final trunk group for each Numbering Plan Area (NPA) within a LATA in order to identify the coin originating NPA.

For access from the TOPS tandem to the customer's POP, the customer must order a separate trunk group for each type of coin control signaling that is utilized among the EAEOs subtending a TOPS tandem.

22.3.3 Testing

The Telephone Company will perform normal acceptance testing for Coin Services as set forth in Section 6. In addition, the Telephone Company will perform testing for coin control and operator functionality features (i.e., coin collect, coin return, 1+ person-to-person, operator recall, overtime, international direct distance dialing and information calls).

The Telephone Company will provide optional testing, at the request of the customer, as set forth in Section 13.

22.3.4 Ordering

Service ordering or modification provisions will apply as set forth in Section 5.

Issued: June 24, 1994

Effective: August 17, 1994

By M. H. SCHULTEIS, Executive Director-External Affairs
Southwestern Bell Telephone Company
St. Louis, Missouri

No Supplement to this tariff will be issued except for the purpose of canceling this tariff.

Access Services Tariff
Section 22
Original Sheet 4

ACCESS SERVICES

22. COIN SERVICES-(Continued)

22.4 Rate Regulations

For customers who choose Option 1 (i.e., receives both 0+ and 1+ interLATA calls directly) or Option 2 (i.e., receives 0+ interLATA calls directly and a secondary service provider receives 1+ interLATA sent-paid traffic), all applicable Switched Access rates and charges in Section 6 and the appropriate Carrier Common Line Access charges in Section 3 will be billed to the customer, whether incurred by the customer or by the secondary service provider on behalf of the customer.

For customers who choose Option 3 (i.e., receives 0+ interLATA calls directly and defaults 1+ interLATA sent-paid traffic), the following charges will be applicable:

The customer will be billed all appropriate Switched Access rates and charges in Section 6 and the Carrier Common Line Access charges as set forth in Section 3 for the 0+ interLATA calls.

The default carrier will be billed all appropriate Switched Access rates and charges as set forth in Section 6 and Carrier Common Line Access charges as set forth in Section 3 for the 1+ interLATA sent-paid traffic.

22.4.1 Liability

Where a customer selects Option 2 (i.e., to receive 0+ interLATA calls directly and a secondary service provider receives 1+ interLATA sent-paid traffic), it shall be the sole duty and obligation of the customer to make any and all arrangements for access billing and settlement with the secondary service provider.

The Telephone Company shall be indemnified, defended and held harmless by the customer and the secondary service provider for any and all claims arising out of any act or omission of the customer and/or secondary service provider relating to access billing, settlement of arrangements and any other issue concerning the relationship between the customer and its authorized secondary service provider.

Issued: June 24, 1994

Effective: August 17, 1994

By M. H. SCHULTEIS, Executive Director-External Affairs
Southwestern Bell Telephone Company
St. Louis, Missouri

No Supplement to this tariff will be issued except for the purpose of canceling this tariff.

Access Services Tariff
Section 22
Original Sheet 5

ACCESS SERVICES

22. COIN SERVICES-(Continued)

22.4 Rate Regulations-(Continued)

22.4.2 Provision of Message Call Detail Concerning Station Monies

Where Operator Trunk-Coin or Combined Coin and Non-Coin or Operator Trunk-Full Feature Optional Features for sent-paid pay telephone access is utilized by the customer or default carrier and the customer or default carrier wishes to receive the monies it is due from the monies collected by the Telephone Company from its pay telephone stations, the customer or default carrier shall furnish to the Telephone Company, at a location specified by the Telephone Company, message call detail for the sent-paid pay telephone calls by the customer, selected secondary service provider or default carrier.

The customer, selected secondary service provider or the default carrier will be required to provide call detail messages in accordance with the industry standard Exchange Message Interface (EMI) format guidelines. If a change to the industry standard format is required, the Telephone Company will provide notification to the involved customer or default carrier six months prior to the change. The message call detail records must be submitted to the Telephone Company on a daily or weekly basis, but in no case, later than 30 days from the message date.

22.4.3 Payment of Sent-Paid Monies

The Telephone Company will collect the monies from coin pay telephone stations and will determine and remit amounts due to a customer or default carrier which is provided Operator Trunk-Coin or Combined Coin and Non-Coin or Operator Trunk-Full Feature Optional Features for sent-paid telephone access as set forth in Section 6 as follows:

A. Bill Period Coin Revenue

The Telephone Company will establish a collection schedule for each of its coin pay telephone stations and will collect the monies from the coin pay stations. The Telephone Company will use trending techniques to develop the optimum coin collection schedule associated with each public telephone account. The Telephone Company's collection schedule may vary for each public telephone account. The monies collected during each bill period established by the Telephone Company will be identified by coin pay telephone station and used to develop Bill Period Coin Revenue for each coin record day (the day a record is prepared and dated to show the amount due the customer or default carrier).

Issued: June 24, 1994

Effective: August 17, 1994

By M. H. SCHULTEIS, Executive Director-External Affairs
Southwestern Bell Telephone Company
St. Louis, Missouri

No Supplement to this tariff will be issued except for the purpose of canceling this tariff.

ACCESS SERVICES

22. COIN SERVICES-(Continued)

22.4 Rate Regulations-(Continued)

22.4.3 Payment of Sent-Paid Monies-(Continued)

B. Total Customer or Default Carrier Coin Revenue

The total customer or default carrier coin revenue will be determined by the Telephone Company based on:

1. The message call detail records received from the customer, its selected secondary service provider or default carrier, as set forth in 22.4.2 for each bill period, and
2. The Telephone Company collection process associated with each public telephone account for sent-paid coin calls.

C. Recourse Adjustments

For each coin record day, the Telephone Company will subtract from the Total Customer or Default Carrier Coin Revenue an amount for coin station shortages. Coin station shortages are amounts resulting from unauthorized calling at coin pay telephone stations, use of unauthorized coins (e.g., foreign coins, slugs and improper use of U.S. pennies), unauthorized removal of coins from coin pay telephone stations and coin refunds beyond the Telephone Company's control.

Such amount for coin station shortages will be developed by the Telephone Company by multiplying the Total Customer or Default Carrier Coin Revenue for each coin record day by a shortage factor. Such amount will be rounded to the nearest penny. The shortage factor will be determined by dividing the yearly total coin shortage amount by the yearly total coin revenue amount (i.e., total coin revenue equals the coin revenue collected under exchange tariffs, state toll tariffs, and interstate toll tariffs). The total coin shortage amount and the total revenue amount will be determined by the Telephone Company through an annual study.

Issued: June 24, 1994

Effective: August 17, 1994

By M. H. SCHULTEIS, Executive Director-External Affairs
Southwestern Bell Telephone Company
St. Louis, Missouri

No Supplement to this tariff will be issued except for the purpose of canceling this tariff.

ACCESS SERVICES

22. COIN SERVICES-(Continued)

22.4 Rate Regulations-(Continued)

22.4.3 Payment of Sent-Paid Monies-(Continued)

D. Payment of Net Customer or Default Carrier Coin Revenue

The Telephone Company will determine the Net Customer or Default Carrier Coin Revenue for each coin record day by subtracting the amount for coin station shortages determined as set forth in C preceding from the Total Customer or Default Carrier Coin Revenue determined as set forth in B preceding.

E. Refund of Monies from Coin Pay Telephone Stations

When the customer does not choose to receive the 1+ interLATA sent-paid traffic, the secondary service provider or the default carrier will be responsible for processing coin refunds to its end user customers.

22.4.4 Audit Provisions

Upon 30-day written notice by the Telephone Company, the customer or the default carrier shall have the right to audit and examine all records and accounts, as may be deemed necessary under recognized accounting practices, which contain information relevant to the determination of the jurisdiction of monies associated with the pay telephones. It shall be the sole responsibility of the customer to obtain all such necessary information from its selected secondary service provider. The Telephone Company, the customer and the default carrier shall have the following audit rights for Coin Services:

- A. The Telephone Company or its authorized representative may, once per year during normal business hours, audit the call message detail records, including any supporting documentation, of the customer, its selected secondary service provider or the default carrier.
- B. The customer, the default carrier or their authorized representative, may once per year during normal business hours, audit the Telephone Company's records and accounts, including any supporting documentation, to determine the amounts payable to the customer or the default carrier.

Issued: June 24, 1994

Effective: August 17, 1994

By M. H. SCHULTEIS, Executive Director-External Affairs
Southwestern Bell Telephone Company
St. Louis, Missouri

No Supplement to this tariff will be issued except for the purpose of canceling this tariff.

ACCESS SERVICES

22. COIN SERVICES-(Continued)

22.4 Rate Regulations-(Continued)

22.4.4 Audit Provisions-(Continued)

- C. If the parties involved mutually agree upon an independent auditor, the Telephone Company and the customer or the default carrier shall agree upon the audit period and make available documentation as set forth in A and B preceding during normal business hours at an agreed upon location.
- D. Adjustment shall be made by the proper party to compensate for any errors or omissions disclosed by such examination or audit. Neither such right to examine and audit nor the right to receive such adjustment shall be affected by any statement to the contrary, appearing on checks or otherwise, unless such statement expressly waiving such right appears in a letter signed by the authorized representative of the party having such right and delivered to the other party.
- E. All information received or reviewed by the Telephone Company, the customer, the default carrier or their authorized representative is to be considered confidential and is not to be distributed, provided or disclosed in any form to any party not involved in the audit, nor is such information to be used for any other purpose.

Issued: June 24, 1994

Effective: August 17, 1994

By M. H. SCHULTEIS, Executive Director-External Affairs
Southwestern Bell Telephone Company
St. Louis, Missouri