

UNITED TELEPHONE COMPANY  
OF MISSOURI d/b/a SPRINT

First Revised Page 101  
Cancels Original Page 101  
**RECEIVED**

ACCESS SERVICE

JAN 15 1997

- 3. Carrier Common Line Access Service (Cont'd)

MISSOURI  
Public Service Commission (D)

(D)

**FILED**

APR 15 1997

**NO PUBLIC EFFECTIVE**

APR 15 1997

ISSUED:  
January 15, 1997

BY: John L. Roe  
VP - Carrier and Regulatory Services  
5454 West 110th Street  
Overland Park, Kansas 66211

UNITED TELEPHONE COMPANY  
OF MISSOURI

Original Page 101

RECEIVED

SEP 17 1992

ACCESS

3. Carrier Common Line Access Service (Cont'd)

MISSOURI  
Public Service Commission

3.6 Payment of Coin Sent-Paid Monies (Cont'd)

(C) Recourse Adjustments

For each coin record day, the Telephone Company will subtract from the Total IC Coin Revenue an amount for coin station shortages. Coin station shortages are amounts resulting from unauthorized calling at coin pay telephone stations, use of unauthorized coins (i.e., foreign coins, slugs, and improper use of U.S. pennies), unauthorized removal of coins from coin pay telephone stations, and coin refunds beyond the Telephone Company's control. Such amount for coin station shortages will be developed by the Telephone Company by multiplying the Total IC Coin Revenue for each coin record day by a shortage factor. Such amount will be rounded to the nearest penny. The shortage factor will be determined by dividing the yearly total coin shortage amount by the yearly total coin revenue amount (i.e. total coin revenue equals the coin revenue due under exchange tariffs, state toll tariffs, and intrastate toll tariffs). The total coin shortage amount and the total revenue amount will be determined by the Telephone Company through an annual special study.

(D) Payment of Net IC Coin Revenue

The Telephone Company will determine the Net IC Coin Revenue for each coin record day by subtracting from the Total IC Coin Revenue, determined as set forth in (B) preceding, the amount for coin station shortages determined as set forth in (C) preceding. On the date (payment date) determined by adding 45 days to the coin record day, the Telephone Company will remit payment to the IC for the Net IC Coin Revenue.

CANCELLED

APR 15 1997  
BY John L. Roe #  
Public Service Commission  
MISSOURI

FILED

NOV 7 1992

MO. PUBLIC SERVICE COMM.  
EFFECTIVE:

~~October 17, 1992~~

NOV 7 1992

ISSUED:  
September 17, 1992

BY: John L. Roe  
Vice President Administration  
5454 West 110th Street  
Overland Park, Kansas, 66211

UNITED TELEPHONE COMPANY  
OF MISSOURI d/b/a SPRINT

First Revised Page 102  
Cancels Original Page 102

ACCESS SERVICE

JAN 13 1997

3. Carrier Common Line Access Service (Cont'd)

MISSOURI  
Public Service Commission (D)

(D)

3.7 Rate Regulations

(A) Access minutes will be accumulated using call detail recorded by Telephone Company equipment and Feature Group C operator and TSPS call detail such as pay telephone sent-paid, operator-DDD, operator-person, collect, credit-card, third number and/or other like calls recorded by the customer. The Telephone company measuring and recording equipment will be associated with end office or local tandem switching equipment and will record each originating and terminating access minute where answer supervision is received. The accumulated access minutes will be summed on a line by line basis, by line group or by end office, whichever type of account is used by the Telephone Company, for each customer and then rounded to the nearest minute.

FILED

APR 15 1997

MO. PUBLIC SERVICE COMMISSION

ISSUED:  
January 15, 1997

BY: John L. Roe  
VP - Carrier and Regulatory Services  
5454 West 110th Street  
Overland Park, Kansas 66211

EFFECTIVE:  
APR 15 1997

UNITED TELEPHONE COMPANY  
OF MISSOURI

Original Page 102

ACCESS

RECEIVED

3. Carrier Common Line Access Service (Cont'd)

SEP 17 1992

3.6 Payment of Coin Sent-Paid Monies (Cont'd)

MISSOURI  
Public Service Commission

(E) Audit Provisions

Upon reasonable written notice by the customer to the Telephone Company, the customer shall have the right, through its authorized representative, to examine and audit, during normal business hours and at reasonable intervals as determined by the Telephone Company, all such records and accounts as may under recognized accounting practices contain information bearing upon the determination of the amount payable to the customer. Adjustment shall be made by the proper party to compensate for any errors or omissions disclosed by such examination or audit. Neither such right to examine and audit nor the right to receive such adjustment shall be affected by any statement to the contrary, appearing on checks or otherwise, unless such statement expressly waiving such right appears in a letter signed by the authorized representative of the party having such right and delivered to the other party.

All information received or reviewed by the customer or its authorized representative is to be considered confidential and is not to be distributed, provided or disclosed in any form to anyone not involved in the audit, nor is such information to be used for any other purpose.

3.7 Rate Regulations

(A) Access minutes will be accumulated using call detail recorded by Telephone Company equipment and Feature Group C operator and TSPS call detail such as pay telephone sent-paid, operator-DDD, operator-person, collect, credit-card, third number and/or other like calls recorded by the customer. The Telephone company measuring and recording equipment will be associated with end office or local tandem switching equipment and will record each originating and terminating access minute where answer supervision is received. The accumulated access minutes will be summed on a line by line basis, by line group or by end office, whichever type of account is used by the Telephone Company, for each customer and then rounded to the nearest minute.

CANCELLED

APR 15 1997  
BY Let P.S. # 102  
Public Service Commission  
MISSOURI

FILED

NOV 7 1992

MO. PUBLIC SERVICE COMMISSION

ISSUED:  
September 17, 1992

BY: John L. Roe  
Vice President Administration  
5454 West 110th Street  
Overland Park, Kansas, 66211

EFFECTIVE:

~~October 1, 1992~~

NOV 7 1992



ACCESS SERVICE

3. Carrier Common Line Access Service (Cont'd)

MAR 27 1996

3.7 Rate Regulations (Cont'd)

- (B) When an access group has usage that originates from and/or terminates at both end offices that have been converted to equal access and end offices that have not been converted, premium access charge per minute rate as set forth in 3.8 following will apply. The minutes billed Carrier Common Line Access Service charges will be the terminating intrastate access minutes plus the originating intrastate access minutes for such access groups.
- (C) When the MTS and/or MTS-type usage is shown in hours, the number of hours shall be multiplied by 60 to develop the associated MTS and/or MTS-type minutes of use. If the MTS and/or MTS-type usage is shown in a unit that does not show hours or minutes, the customer shall provide a factor to convert the shown units to minutes.
- (D) When the customer reports interstate and intrastate interLATA and intrastate intraLATA use of Switched Access Service, the Carrier Common Line Access Charges in this tariff will be billed only to intrastate interLATA and intrastate intraLATA Switched Access Service access minutes based on the data reported by the customer as set forth in 2.3.14 preceding. The intrastate interLATA and intrastate intraLATA Switched Access Service access minutes will be used to determine Carrier Common Line Charges as set forth in (E) following.
- (E) The access minutes for all premium rated Switched Access Service subject to Carrier Common Line charges will be multiplied by the Premium Access per minute rate as set forth in 3.8 following to determine the charges.

Terminating Access, per minute charges(s) apply to all terminating access minutes of use.

Terminating Access, per minute charge(s) apply to all originating access minutes of use associated with calls placed to 700, TFC and 900 numbers, less those originating access minutes of use associated with calls placed to 700, TFC and 900 numbers for which the customer furnishes for each month a report of either the number of calls or minutes, or a report of the percent of calls or minutes that terminate in a Switched Access Service that is assessed Carrier Common Line charges. (T)

Originating Access per minute charge(s) apply to all originating access minutes of use. (T)

Originating Access, per minute charge(s) apply less all originating access minutes of use associated with calls placed to 700, TFC and 900 numbers; plus all originating access minutes of use associated with calls placed to 700, TFC and 900 numbers for which the customer furnishes for each month a report of either the number of calls or minutes, or a report of the percent of calls or minutes that terminate (T)

MAR 27 1996

MAR 27 1996

ISSUED:  
March 27, 1996

BY: John L. Roe  
Vice President - Carrier and Regulatory Services  
5454 West 110th Street  
Overland Park, Kansas 66211

EFFECTIVE:  
April 29, 1996

ACCESS SERVICE

NOV 2 1993

3. Carrier Common Line Access Service (Cont'd)

3.7 Rate Regulations (Cont'd)

MO. PUBLIC SERVICE COMM.

(B) When an access group has usage that originates from and/or terminates at both end offices that have been converted to equal access and end offices that have not been converted, premium access charge per minute rate as set forth in 3.8 following will apply. The minutes billed Carrier Common Line Access Service charges will be the terminating intrastate access minutes plus the originating intrastate access minutes for such access groups.

(C) When the MTS and/or MTS-type usage is shown in hours, the number of hours shall be multiplied by 60 to develop the associated MTS and/or MTS-type minutes of use. If the MTS and/or MTS-type usage is shown in a unit that does not show hours or minutes, the customer shall provide a factor to convert the shown units to minutes.

(D) When the customer reports interstate and intrastate interLATA and intrastate intraLATA use of Switched Access Service, the Carrier Common Line Access Charges in this tariff will be billed only to intrastate interLATA and intrastate intraLATA Switched Access Service access minutes based on the data reported by the customer as set forth in 2.3.14 preceding. The intrastate interLATA and intrastate intraLATA Switched Access Service access minutes will be used to determine Carrier Common Line Charges as set forth in (E) following.

(E) The access minutes for all premium rated Switched Access Service subject to Carrier Common Line charges will be multiplied by the Premium Access per minute rate as set forth in 3.8 following to determine the charges.

Terminating Access, per minute charges(s) apply to all terminating access minutes of use.

Terminating Access, per minute charge(s) apply to all originating access minutes of use associated with calls placed to 700, 800 and 900 numbers, less those originating access minutes of use associated with calls placed to 700, 800 and 900 numbers for which the customer furnishes for each month a report of either the number of calls or minutes, or a report of the percent of calls or minutes that terminate in a Switched Access Service that is assessed Carrier Common Line charges.

Originating Access per minute charge(s) apply to all originating access minutes of use.

Originating Access, per minute charge(s) apply less all originating access minutes of use associated with calls placed to 700, 800 and 900 numbers; plus all originating access minutes of use associated with calls placed to 700, 800 and 900 numbers for which the customer furnishes for each month a report of either the number of calls or minutes, or a report of the percent of calls or minutes that terminate

**CANCELLED**  
APR 29 1996  
BY 2  
Public Service Commission  
MISSOURI

**FILED**

ISSUED:  
November 3, 1993

BY: John L. Roe  
Vice President - Administration  
5454 West 110th Street  
Overland Park, Kansas 66211

NOV 7 1993  
93 - 181

EFFECTIVE:  
November 7, 1993

MO. PUBLIC SERVICE COMM.

UNITED TELEPHONE COMPANY  
OF MISSOURI

Original Page 103

RECEIVED

SEP 17 1992

ACCESS

3. Carrier Common Line Access Service (Cont'd)

3.7 Rate Regulations (Cont'd)

MISSOURI  
Public Service Commission

- (B) When an access group has usage that originates from and/or terminates at both end offices that have been converted to equal access and end offices that have not been converted, premium access charge per minute rate as set forth in 3.8 following will apply. The minutes billed Carrier Common Line Access Service charges will be the terminating intrastate access minutes plus the originating intrastate access minutes for such access groups.
- (C) When the MTS and/or MTS-type usage is shown in hours, the number of hours shall be multiplied by 60 to develop the associated MTS and/or MTS-type minutes of use. If the MTS and/or MTS-type usage is shown in a unit that does not show hours or minutes, the customer shall provide a factor to convert the shown units to minutes.
- (D) When the customer reports interstate and intrastate interLATA and intrastate intraLATA use of Switched Access Service, the Carrier Common Line Access Charges in this tariff will be billed only to intrastate interLATA and intrastate intraLATA Switched Access Service access minutes based on the data reported by the customer as set forth in 2.3.14 preceding. The intrastate interLATA and intrastate intraLATA Switched Access Service access minutes will be used to determine Carrier Common Line Charges as set forth in (E) following.
- (E) The access minutes for all premium rated Switched Access Service subject to Carrier Common Line charges will be multiplied by the Premium Access per minute rate as set forth in 3.8 following to determine the charges.

The terminating Premium Access, per minute charges(s) apply to all terminating access minutes of use.

The originating Premium Access per minute charge(s) apply to all originating access minutes of use.

CANCELLED

NOV 7 1993  
BY *let R. S. #103*  
Public Service Commission  
MISSOURI

FILED

NOV 7 1992

NO. PUBLIC SERVICE COMM.  
EFFECTIVE:

~~October 1, 1992~~

NOV 7 1992

ISSUED:  
September 17, 1992

BY: John L. Roe  
Vice President Administration  
5454 West 110th Street  
Overland Park, Kansas, 66211



ACCESS SERVICE

3. Carrier Common Line Access Service (Cont'd)

NOV 2 1993

3.7 Rate Regulations (Cont'd)

in a Switched Access Service that is assessed Carrier Common Line charges, and for which a corresponding reduction in the number of terminating access minutes of use has been made. (N)  
|  
(N)

- (F) When the customer orders a combined access group to be used in conjunction with the resale of MTS/WATS and/or MTS/WATS-type services as set forth in 3.3 preceding, subject to the limitations as set forth in 3.2, preceding, and the Telephone Company receives the usage information required to calculate the proration as set forth in 3.4. F., preceding, the customer will be billed as set forth in 3.7(F)(1) following. When more than one combined access group is provided in a LATA, the Telephone Company will apportion the resold MTS/WATS and/or MTS/WATS-type services and originating minutes of use among the combined access groups. Such apportionment will be based on the relationship of the originating usage for each combined access groups in the LATA. The involved resold minutes shall be only intrastate outward MTS, MTS-type, WATS and WATS-type minutes and shall not include collect, third number, credit card or interstate minutes of use.

In order for the rate regulations to apply as set forth following, the combined access group and the resold MTS/WATS and/or MTS/WATS-type services must be provided in the same state in the same LATA, provided by the same Telephone Company and connected directly or indirectly. For those LATAs that have more than one state, the customer shall report the information by state within the LATA.

Each of the combined access groups arranged in a multiline hunt group used by the customer in association with the resold MTS/WATS and/or MTS/WATS-type services must be connected either directly or indirectly to the customers' designated premises at which the resold MTS/WATS and/or MTS/WATS-type services are terminated. Direct connections are those arrangements where the combined access groups and resold MTS/WATS and/or MTS/WATS-type services are terminated at the same customers' designated premises. Indirect connections are those arrangements where the combined access groups and resold MTS/WATS and/or MTS/WATS-type are terminated at different customer designated premises in the same LATA. Such different customer designated premises are connecting by facilities that permit a call to flow from combined access groups to resold MTS/WATS and/or MTS/WATS-type services.

FILED

NOV 7 1993  
93 - 181  
MO. PUBLIC SERVICE COMM.

ISSUED:  
November 3, 1993

BY: John L. Roe  
Vice President - Administration  
5454 West 110th Street  
Overland Park, Kansas 66211

EFFECTIVE:  
November 7, 1993

Cancelled

UNITED TELEPHONE COMPANY  
OF MISSOURI

Original Page 104

RECEIVED

SEP 17 1992

ACCESS

3. Carrier Common Line Access Service (Cont'd)

MISSOURI  
Public Service Commission

3.7 Rate Regulations (Cont'd)

(F) When the customer orders a combined access group to be used in conjunction with the resale of MTS/WATS and/or MTS/WATS-type services as set forth in 3.3 preceding, subject to the limitations as set forth in 3.2, preceding, and the Telephone Company receives the usage information required to calculate the proration as set forth in 3.4. F., preceding, the customer will be billed as set forth in 3.7(F)(1) following. When more than one combined access group is provided in a LATA, the Telephone Company will apportion the resold MTS/WATS and/or MTS/WATS-type services and originating minutes of use among the combined access groups. Such apportionment will be based on the relationship of the originating usage for each combined access groups in the LATA. The involved resold minutes shall be only intrastate outward MTS, MTS-type, WATS and WATS-type minutes and shall not include collect, third number, credit card or interstate minutes of use.

In order for the rate regulations to apply as set forth following, the combined access group and the resold MTS/WATS and/or MTS/WATS-type services must be provided in the same state in the same LATA, provided by the same Telephone Company and connected directly or indirectly. For those LATAs that have more than one state, the customer shall report the information by state within the LATA.

Each of the combined access groups arranged in a multiline hunt group used by the customer in association with the resold MTS/WATS and/or MTS/WATS-type services must be connected either directly or indirectly to the customers' designated premises at which the resold MTS/WATS and/or MTS/WATS-type services are terminated. Direct connections are those arrangements where the combined access groups and resold MTS/WATS and/or MTS/WATS-type services are terminated at the same customers' designated premises. Indirect connections are those arrangements where the combined access groups and resold MTS/WATS and/or MTS/WATS-type are terminated at different customer designated premises in the same LATA. Such different customer designated premises are connecting by facilities that permit a call to flow from combined access groups to resold MTS/WATS and/or MTS/WATS-type services.

CANCELLED

NOV 7 1992  
BY 1st R.S. #104  
Public Service Commission  
MISSOURI

FILED

NOV 7 1992

MO. PUBLIC SERVICE COMMISSION  
EFFECTIVE:  
~~October 17, 1992~~  
NOV 7 1992

ISSUED:  
September 17, 1992

BY: John L. Roe  
Vice President Administration  
5454 West 110th Street  
Overland Park, Kansas, 66211

UNITED TELEPHONE COMPANY  
OF MISSOURI

Original Page 105

ACCESS SERVICE

RECEIVED

3. Carrier Common Line Access Service (Cont'd)

SEP 17 1992

3.7 Rate Regulations (Cont'd)

MISSOURI  
PUBLIC SERVICE COMMISSION

(F) (Cont'd)

The adjustments as set forth following will be computed separately for each combined access group.

(1) Combined Access Groups

When combined access groups are provided in a LATA, the following regulations apply:

- (a) One intrastate MTS/WATS-type Feature Group A Switched Access Service for each resold intrastate WATS and WATS-type service reported as set forth in 3.4.(F).. preceding, and c.d. and e., following, will be billed local business exchange service rates. The exchange involved shall be the exchange in which the service provided.
- (b) For MTS/WATS-type Feature Group A provided in a combined access group, the minutes billed will be all the terminating intrastate access minutes and any adjusted originating intrastate access minutes for such combined access groups. The adjusted originated minutes billed will be the originating intrastate access minutes less the reported resold service(s) originating minutes of use.
- (c) The number of line side Switched Access Services billed at local business exchange service rates shall not exceed the number of line side connections provided in line side combined access groups in service in a LATA.
- (d) No local Measured Service minutes are billed for terminating usage because all the terminating access minutes are billed Switched Access Service access minutes.

ISSUED:  
September 17, 1992

BY: John L. Roe  
Vice President Administration  
5454 West 110th Street  
Overland Park, Kansas, 66211

FILED  
NOV 7 1992  
MISSOURI  
PUBLIC SERVICE COMMISSION  
EFFECTIVE:  
~~September 17, 1992~~  
NOV 7 1992



ACCESS

3. Carrier Common Line Access Service (Cont'd)

3.7 Rate Regulations (Cont'd)

(F) (Cont'd)

(1) Combined Access Groups-(Cont'd)

(e) For the first month a combined access group is in service each associated resold WATS and WATS-type service will be assumed to have 2500 or more originating intrastate minutes of use. After the first month that both the combined access group and the associated resold WATS and WATS-type services are in service, each resold WATS and Wats-type service shall have 2500 or more originating intrastate minutes of use per month on average. If the average originating intrastate usage per service for each resold WATS and WATS-type service group does not equal 2500 originating minutes of use in any month, then for combined access billing purposes, the number of WATS and WATS-type services for which local business exchange service rates will be applicable will be reduced until the average originating intrastate usage per month for the remaining services equals or exceeds 2500 originating intrastate minutes. The number of originating minutes per month per resold WATS and WATS-type services will be developed by adding the resold outward MTS and MTS-type minutes to the resold originating WATS and WATS-type minutes and dividing the resulting sum per service group by the number of services in the group.

(2) Any adjustment will be made to the involved customer account no later than either the next bill date, or the one subsequent to that, depending on when the usage report is obtained.

(3) When the resold service(s) usage is shown in hours, the number of hours shall be multiplied by 60 to develop the associated WATS-type and WATS minutes of use. If the resold service(s) usage is shown in a unit that does not show hours or minutes, the customer shall provide a factor to convert the shown units to minutes.

(4) The adjusted originating intrastate access minutes for Carrier Common Line Access, that are billed to a customer in a monthly period, shall not be less than zero.

RECEIVED

SEP 17 1992

MISSOURI  
Public Service Commission

ISSUED:  
September 17, 1992

BY: John L. Roe  
Vice President Administration  
5454 West 110th Street  
Overland Park, Kansas, 66211

FILED  
NOV 7 1992  
EFFECTIVE:  
~~October 17, 1992~~  
NOV 7 1992



ACCESS SERVICE

3. Carrier Common Line Access Service (Cont'd)

3.7 Rate Regulations (Cont'd)

(F) (Cont'd)

(5) If the required documentation is not received by the Telephone Company, as described in 3.4.F. preceding, for any subsequent month, no adjustment or credit will be made until the required documentation is delivered to the Telephone company by the customer.

(G) When the customer reports interstate and intrastate use of Switched Access Service, the intrastate Switched Access Service access minutes will be billed interLATA or intraLATA Carrier Common Line Charges based on the date reported by the customer as set forth in 2.3.14 (A) and 2.3.15. The appropriate intrastate Switched Access Service access minutes will, after adjustment as set forth in 3.7.F preceding, when necessary, be used to determine the Carrier Common Line Charges.

3.8 Rates and Charges

The rate for interLATA Carrier Common Line Access is:

	Rate Per Access Minute	
- Terminating	\$0.000000 (R)	(C)
- Originating	\$0.029494	

The rate for intraLATA Carrier Common Line Access is:

	Rate Per Access Minute	
- Terminating	\$0.000000 (R)	(C)
- Originating	\$0.029494	

ISSUED:  
May 1, 2013

Gary L. Kepley  
Director - Regulatory Operations  
5454 W. 110th Street  
Overland Park, Kansas 66211

EFFECTIVE:  
July 2, 2013

ACCESS SERVICE

3. Carrier Common Line Access Service (Cont'd)

3.7 Rate Regulations (Cont'd)

(F) (Cont'd)

(5) If the required documentation is not received by the Telephone Company, as described in 3.4.F. preceding, for any subsequent month, no adjustment or credit will be made until the required documentation is delivered to the Telephone company by the customer.

(G) When the customer reports interstate and intrastate use of Switched Access Service, the intrastate Switched Access Service access minutes will be billed interLATA or intraLATA Carrier Common Line Charges based on the date reported by the customer as set forth in 2.3.14 (A) and 2.3.15. The appropriate intrastate Switched Access Service access minutes will, after adjustment as set forth in 3.7.F preceding, when necessary, be used to determine the Carrier Common Line Charges.

3.8 Rates and Charges

The rate for interLATA Carrier Common Line Access is:

	Rate Per Access Minute
- Terminating	\$0.006790 (R)
- Originating	\$0.029494

The rate for intraLATA Carrier Common Line Access is:

	Rate Per Access Minute
- Terminating	\$0.006790 (R)
- Originating	\$0.029494

ISSUED:  
May 1, 2012

Gary L. Kepley  
Director – Regulatory Systems  
5454 W. 110th Street  
Overland Park, Kansas 66211

EFFECTIVE:  
July 3, 2012

**FILED**  
**Missouri Public**  
**Service Commission**  
**TT-2012-0317, YI-2012-0635**

ACCESS SERVICE

3. Carrier Common Line Access Service (Cont'd)

3.7 Rate Regulations (Cont'd)

(F) (Cont'd)

(5) If the required documentation is not received by the Telephone Company, as described in 3.4.F. preceding, for any subsequent month, no adjustment or credit will be made until the required documentation is delivered to the Telephone company by the customer.

(G) When the customer reports interstate and intrastate use of Switched Access Service, the intrastate Switched Access Service access minutes will be billed interLATA or intraLATA Carrier Common Line Charges based on the date reported by the customer as set forth in 2.3.14 (A) and 2.3.15. The appropriate intrastate Switched Access Service access minutes will, after adjustment as set forth in 3.7.F preceding, when necessary, be used to determine the Carrier Common Line Charges.

3.8 Rates and Charges

The rate for interLATA Carrier Common Line Access is:

	Rate Per Access Minute
- Terminating	\$0.035603 (R)
- Originating	\$0.029494

The rate for intraLATA Carrier Common Line Access is:

	Rate Per Access Minute
- Terminating	\$0.035603 (R)
- Originating	\$0.029494

ISSUED:  
February 15, 2012

Gary L. Kepley  
Director – Regulatory Systems  
5454 W. 110th Street  
Overland Park, Kansas 66211

EFFECTIVE:  
March 1, 2012

CANCELED  
July 1, 2012  
Missouri Public  
Service Commission  
TT-2012-0317, YI-2012-0635

FILED  
Missouri Public  
Service Commission  
JI-2012-0384

ACCESS SERVICE

3. Carrier Common Line Access Service (Cont'd)

3.7 Rate Regulations (Cont'd)

(F) (Cont'd)

(5) If the required documentation is not received by the Telephone Company, as described in 3.4.F. preceding, for any subsequent month, no adjustment or credit will be made until the required documentation is delivered to the Telephone company by the customer.

(G) When the customer reports interstate and intrastate use of Switched Access Service, the intrastate Switched Access Service access minutes will be billed interLATA or intraLATA Carrier Common Line Charges based on the date reported by the customer as set forth in 2.3.14 (A) and 2.3.15. The appropriate intrastate Switched Access Service access minutes will, after adjustment as set forth in 3.7.F preceding, when necessary, be used to determine the Carrier Common Line Charges.

3.8 Rates and Charges

The rate for interLATA Carrier Common Line Access is:

	Rate Per Access Minute
- Terminating	\$0.044458 (R)
- Originating	\$0.029494 (R)

The rate for intraLATA Carrier Common Line Access is:

	Rate Per Access Minute
- Terminating	\$0.044458 (R)
- Originating	\$0.029494 (R)

ISSUED:  
February 16, 2011

**CANCELED**  
March 1, 2012  
Missouri Public  
Service Commission  
JI-2012-0384

Gary L. Kepley  
Director – Regulatory Systems  
5454 W. 110th Street  
Overland Park, Kansas 66211

EFFECTIVE: (C)  
March 1, 2011 (C)

**Filed**  
Missouri Public  
Service Commission  
JI-2011-0415

ACCESS SERVICE

3. Carrier Common Line Access Service (Cont'd)

3.7 Rate Regulations (Cont'd)

(F) (Cont'd)

(5) If the required documentation is not received by the Telephone Company, as described in 3.4.F. preceding, for any subsequent month, no adjustment or credit will be made until the required documentation is delivered to the Telephone company by the customer.

(G) When the customer reports interstate and intrastate use of Switched Access Service, the intrastate Switched Access Service access minutes will be billed interLATA or intraLATA Carrier Common Line Charges based on the date reported by the customer as set forth in 2.3.14 (A) and 2.3.15. The appropriate intrastate Switched Access Service access minutes will, after adjustment as set forth in 3.7.F preceding, when necessary, be used to determine the Carrier Common Line Charges.

3.8 Rates and Charges

The rate for interLATA Carrier Common Line Access is:

	Rate Per Access Minute
- Terminating	\$0.049583
- Originating	\$0.032894

The rate for intraLATA Carrier Common Line Access is:

	Rate Per Access Minute
- Terminating	\$0.049583
- Originating	\$0.032894

ISSUED:  
March 30, 2007

Mark D. Harper  
Director - State Regulatory  
5454 W. 110th Street  
Overland Park, Kansas 66211

EFFECTIVE:  
April 30, 2007

CANCELLED  
March 1, 2011  
Missouri Public  
Service Commission  
JI-2011-0415

**Filed**  
Missouri Public  
Service Commission

SPRINT MISSOURI INC.  
d/b/a SPRINT

Eleventh Revised Page 107  
Cancels Tenth Revised Page 107

ACCESS SERVICE

3. Carrier Common Line Access Service (Cont'd)

3.7 Rate Regulations (Cont'd)

(F) (Cont'd)

(5) If the required documentation is not received by the Telephone Company, as described in 3.4.F. preceding, for any subsequent month, no adjustment or credit will be made until the required documentation is delivered to the Telephone company by the customer.

(G) When the customer reports interstate and intrastate use of Switched Access Service, the intrastate Switched Access Service access minutes will be billed interLATA or intraLATA Carrier Common Line Charges based on the date reported by the customer as set forth in 2.3.14 (A) and 2.3.15. The appropriate intrastate Switched Access Service access minutes will, after adjustment as set forth in 3.7.F preceding, when necessary, be used to determine the Carrier Common Line Charges.

3.8 Rates and Charges

The rate for interLATA Carrier Common Line Access is:

		Rate Per Access Minute	
-	Terminating	<b>\$0.049583</b>	(R)
-	Originating	<b>\$0.032894</b>	(R)

The rate for intraLATA Carrier Common Line Access is:

		Rate Per Access Minute	
-	Terminating	<b>\$0.049583</b>	(R)
-	Originating	<b>\$0.032894</b>	(R)

ISSUED:  
December 2, 2005

Richard D. Lawson  
State Executive, External Affairs  
319 Madison  
Jefferson City, MO 65101

EFFECTIVE:  
January 18, 2006

**FILED**  
**MO PSC**

Cancelled

ACCESS SERVICE

3. Carrier Common Line Access Service (Cont'd)

3.7 Rate Regulations (Cont'd)

(F) (Cont'd)

(5) If the required documentation is not received by the Telephone Company, as described in 3.4.F. preceding, for any subsequent month, no adjustment or credit will be made until the required documentation is delivered to the Telephone company by the customer.

(G) When the customer reports interstate and intrastate use of Switched Access Service, the intrastate Switched Access Service access minutes will be billed interLATA or intraLATA Carrier Common Line Charges based on the date reported by the customer as set forth in 2.3.14 (A) and 2.3.15. The appropriate intrastate Switched Access Service access minutes will, after adjustment as set forth in 3.7.F preceding, when necessary, be used to determine the Carrier Common Line Charges.

3.8 Rates and Charges

The rate for interLATA Carrier Common Line Access is:

	Rate Per Access Minute	
- Terminating	<b>\$0.051457</b>	(R)
- Originating	<b>\$0.034150</b>	(R)

The rate for intraLATA Carrier Common Line Access is:

	Rate Per Access Minute	
- Terminating	<b>\$0.051457</b>	(R)
- Originating	<b>\$0.034150</b>	(R)

ISSUED:  
December 3, 2004

Richard D. Lawson  
State Executive, External Affairs  
319 Madison  
Jefferson City, MO 65101

EFFECTIVE:  
January 18, 2005



SPRINT MISSOURI INC.  
d/b/a SPRINT

Ninth Revised Page 107  
Cancels Eighth Revised Page 107

**Missouri Public**

ACCESS SERVICE

REC'D OCT 31 2003

3. Carrier Common Line Access Service (Cont'd)

Service Commission

3.7 Rate Regulations (Cont'd)

(F) (Cont'd)

(5) If the required documentation is not received by the Telephone Company, as described in 3.4.F. preceding, for any subsequent month, no adjustment or credit will be made until the required documentation is delivered to the Telephone company by the customer.

(G) When the customer reports interstate and intrastate use of Switched Access Service, the intrastate Switched Access Service access minutes will be billed interLATA or intraLATA Carrier Common Line Charges based on the date reported by the customer as set forth in 2.3.14 (A) and 2.3.15. The appropriate intrastate Switched Access Service access minutes will, after adjustment as set forth in 3.7.F preceding, when necessary, be used to determine the Carrier Common Line Charges.

3.8 Rates and Charges

The rate for interLATA Carrier Common Line Access is:

		Rate Per Access Minute	
-	Terminating	\$ 0.054065	(R)
-	Originating	\$ 0.035917	

The rate for intraLATA Carrier Common Line Access is:

		Rate Per Access Minute	
-	Terminating	\$ 0.054065	(R)
-	Originating	\$ 0.035917	

**CANCELLED**

JAN 18 2005  
By *10425107*  
Public Service Commission  
MISSOURI

ISSUED:  
October 31, 2003

Richard D. Lawson  
State Executive, External Affairs  
319 Madison  
Jefferson City, MO 65101

EFFECTIVE:  
~~December 18, 2003~~

JAN 17 2004

Missouri Public  
Service Commission

IT-2004-0229  
FILED JAN 17 2004

SPRINT MISSOURI INC.  
d/b/a SPRINT

Eighth Revised Page 107  
Cancels Seventh Revised Page 107

ACCESS SERVICE

**Missouri Public**

3. Carrier Common Line Access Service (Cont'd)

REC'D SEP 02 2003

3.7 Rate Regulations (Cont'd)

Service Commission

(F) (Cont'd)

(5) If the required documentation is not received by the Telephone Company, as described in 3.4.F. preceding, for any subsequent month, no adjustment or credit will be made until the required documentation is delivered to the Telephone company by the customer.

(G) When the customer reports interstate and intrastate use of Switched Access Service, the intrastate Switched Access Service access minutes will be billed interLATA or intraLATA Carrier Common Line Charges based on the date reported by the customer as set forth in 2.3.14 (A) and 2.3.15. The appropriate intrastate Switched Access Service access minutes will, after adjustment as set forth in 3.7.F preceding, when necessary, be used to determine the Carrier Common Line Charges.

3.8 Rates and Charges

The rate for interLATA Carrier Common Line Access is:

	Rate Per Access Minute	
- Terminating	\$ 0.054133	(R)
- Originating	\$ 0.035917	(R)

The rate for intraLATA Carrier Common Line Access is:

	Rate Per Access Minute	
- Terminating	\$ 0.054133	(R)
- Originating	\$ 0.035917	(R)

**CANCELLED**  
JAN 17 2004  
By 94hrs/167  
Public Service Commission  
MISSOURI

ISSUED:  
August 29, 2003

Richard D. Lawson  
State Executive, External Affairs  
319 Madison  
Jefferson City, MO 65101

EFFECTIVE:  
December 18, 2003

Missouri Public  
Service Commission  
IT-04-134  
FILED DEC 18 2003

SPRINT MISSOURI INC.  
d/b/a SPRINT

Seventh Revised Page 107  
Cancels Sixth Revised Page 107

ACCESS SERVICE

Missouri Public  
Service Commission

3. Carrier Common Line Access Service (Cont'd)

REC'D OCT 25 2002

3.7 Rate Regulations (Cont'd)

(F) (Cont'd)

(5) If the required documentation is not received by the Telephone Company, as described in 3.4.F. preceding, for any subsequent month, no adjustment or credit will be made until the required documentation is delivered to the Telephone company by the customer.

(G) When the customer reports interstate and intrastate use of Switched Access Service, the intrastate Switched Access Service access minutes will be billed interLATA or intraLATA Carrier Common Line Charges based on the date reported by the customer as set forth in 2.3.14 (A) and 2.3.15. The appropriate intrastate Switched Access Service access minutes will, after adjustment as set forth in 3.7.F preceding, when necessary, be used to determine the Carrier Common Line Charges.

3.8 Rates and Charges

The rate for interLATA Carrier Common Line Access is:

		Rate Per Access Minute	
-	Terminating	\$ 0.060373	(R)
-	Originating	\$ 0.040059	

The rate for intraLATA Carrier Common Line Access is:

		Rate Per Access Minute	
-	Terminating	\$ 0.060373	(R)
-	Originating	\$ 0.040059	

CANCELLED

DEC 18 2003

By *8th RS 107*  
Public Service Commission  
MISSOURI

ISSUED:  
October 25, 2002

Richard D. Lawson  
State Executive, External Affairs  
319 Madison  
Jefferson City, MO 65101

EFFECTIVE:  
December 11, 2002

Missouri Public  
Service Commission  
*IT-2003-0176*  
FILED DEC 11 2002

SPRINT MISSOURI INC.  
d/b/a SPRINT

Sixth Revised Page 107  
Cancels Fifth Revised Page 107

ACCESS SERVICE

Missouri Public

3. Carrier Common Line Access Service (Cont'd)

REC'D OCT 26 2001

3.7 Rate Regulations (Cont'd)

Service Commission

(F) (Cont'd)

(5) If the required documentation is not received by the Telephone Company, as described in 3.4.F. preceding, for any subsequent month, no adjustment or credit will be made until the required documentation is delivered to the Telephone company by the customer.

(G) When the customer reports interstate and intrastate use of Switched Access Service, the intrastate Switched Access Service access minutes will be billed interLATA or intraLATA Carrier Common Line Charges based on the date reported by the customer as set forth in 2.3.14 (A) and 2.3.15. The appropriate intrastate Switched Access Service access minutes will, after adjustment as set forth in 3.7.F preceding, when necessary, be used to determine the Carrier Common Line Charges.

3.8 Rates and Charges

The rate for interLATA Carrier Common Line Access is:

	Rate Per Access Minute
- Terminating	\$ 0.067785 (R)
- Originating	\$ 0.040059

The rate for intraLATA Carrier Common Line Access is:

	Rate Per Access Minute
- Terminating	\$ 0.067785 (R)
- Originating	\$ 0.040059 (R)

CANCELLED

DEC 11 2002

THRS 107  
Public Service Commission  
MISSOURI

ISSUED:  
October 26, 2001

Richard D. Lawson  
State Executive, External Affairs  
319 Madison  
Jefferson City, MO 65101

Missouri Public  
EFFECTIVE:  
December 11, 2001  
FILED DEC 11 2001  
02-251  
Service Commission

SPRINT MISSOURI INC.  
d/b/a SPRINT

Fifth Revised Page 107  
Cancels Fourth Revised Page 107

ACCESS SERVICE

Missouri Public  
Service Commission

3. Carrier Common Line Access Service (Cont'd)

REC'D OCT 27 2000

3.7 Rate Regulations (Cont'd)

(F) (Cont'd)

(5) If the required documentation is not received by the Telephone Company, as described in 3.4.F. preceding, for any subsequent month, no adjustment or credit will be made until the required documentation is delivered to the Telephone company by the customer. (T)

(G) When the customer reports interstate and intrastate use of Switched Access Service, the intrastate Switched Access Service access minutes will be billed interLATA or intraLATA Carrier Common Line Charges based on the date reported by the customer as set forth in 2.3.14 (A) and 2.3.15. The appropriate intrastate Switched Access Service access minutes will, after adjustment as set forth in 3.7.F preceding, when necessary, be used to determine the Carrier Common Line Charges. (T)

3.8 Rates and Charges

The rate for interLATA Carrier Common Line Access is:

	Rate Per Access Minute	
- Terminating	\$ 0.075830	(R)
- Originating	\$ 0.040059	(R)

The rate for intraLATA Carrier Common Line Access is:

	Rate Per Access Minute	
- Terminating	\$ 0.076480	(R)
- Originating	\$ 0.042511	(R)

CANCELLED  
DEC 11 2001  
By WHP 107  
Public Service Commission  
MISSOURI

Missouri Public  
Service Commission

FILED DEC 11 2000

ISSUED:  
October 27, 2000

Richard D. Lawson  
State Executive, External Affairs  
319 Madison  
Jefferson City, MO 65101

EFFECTIVE:  
December 11, 2000

UNITED TELEPHONE COMPANY  
OF MISSOURI d/b/a SPRINT

Fourth Revised Page 107  
Cancels Third Revised Page 107

ACCESS SERVICE

3. Carrier Common Line Access Service (Cont'd)

Missouri Public  
Service Commission

REC'D SEP 05 2000

3.7 Rate Regulations (Cont'd)

(F) (Cont'd)

(5) If the required documentation is not received by the Telephone Company, as described in 3.4.F., preceding for any subsequent month, no adjustment or credit will be made until the required documentation is delivered to the Telephone company by the customer.

(G) When the customer report interstate and intrastate use of Switched Access Service, the intrastate Switched Access Service access minutes will be billed interLATA or intraLATA Carrier Common Line Charges based on the date reported by the customer as set forth in 2.3.14 (A) and 2.3.15. The appropriate intrastate Switched Access Service access minutes will, after adjustment as set forth in 3.7.F preceding, when necessary, be used to determine the Carrier Common Line Charges.

(D)

**CANCELLED**

DEC 11 2000

By 5<sup>th</sup> RP 107  
Public Service Commission  
MISSOURI

(D)

3.8 Rates and Charges

The rate for interLATA Carrier Common Line Access is:

		Rate Per Access Minute	
-	Terminating	\$.083479	
-	Originating	\$.044100	(R)

The rate for intraLATA Carrier Common Line Access is:

		Rate Per Access Minute	
-	Terminating	\$.084194	
-	Originating	\$.046800	(R)

Missouri Public  
Service Commission

FILED OCT 05 2000

ISSUED:  
September 5, 2000

EFFECTIVE:  
October 5, 2000

Richard D. Lawson  
State Executive, External Affairs  
319 Madison  
Jefferson City, MO 65101

UNITED TELEPHONE COMPANY  
OF MISSOURI d/b/a SPRINT

Third Revised Page 107  
Cancels Second Revised Page 107

ACCESS SERVICE

RECEIVED

3. Carrier Common Line Access Service (Cont'd)

MAY 29 1997

3.7 Rate Regulations (Cont'd)

MISSOURI  
Public Service Commission

(F) (Cont'd)

(5) If the required documentation is not received by the Telephone Company, as described in 3.4.F., preceding for any subsequent month, no adjustment or credit will be made until the required documentation is delivered to the Telephone company by the customer.

(G) When the customer report interstate and intrastate use of Switched Access Service, the intrastate Switched Access Service access minutes will be billed interLATA or intraLATA Carrier Common Line Charges based on the date reported by the customer as set forth in 2.3.14 (A) and 2.3.15. The appropriate intrastate Switched Access Service access minutes will, after adjustment as set forth in 3.7.F preceding, when necessary, be used to determine the Carrier Common Line Charges.

(H) A 1+ IntraLATA Equal Access Recovery Charge of \$.000591 will be included in the Carrier Common Line rates to recover those costs that the Telephone Company incurs solely in connection with the implementation of intraLATA equal access. This charge will be in effect for 3 years from the date of the first exchange implementation and recovers costs associated with network reconfigurations and system and switch upgrades required to provide 1+ IntraLATA equal access.

The 1+ IntraLATA Equal Access Recovery Charge is assessed to the customer based on the total number of intrastate access minutes. The rates are set forth in 3.8, following:

3.8 Rates and Charges

The rate for interLATA Carrier Common Line Access is:

	Rate Per Access Minute
- Terminating	\$.083479
- Originating	\$.044691

The rate for intraLATA Carrier Common Line Access is:

	Rate Per Access Minute
- Terminating	\$.084194
- Originating	\$.047391

(N)

(N)

(I)

(I)

CANCELLED

OCT 05 2000  
BY 4/11/98 #107  
Public Service Commission  
MISSOURI

ISSUED:  
May 29, 1997

BY: John L. Roe  
VP - Carrier and Regulatory Services  
5454 West 110th Street  
Overland Park, Kansas 66211

FILED

EFFECTIVE:  
June 30, 1997

JUN 30 1997  
97-253  
MO. PUBLIC SERVICE COM



ACCESS SERVICE

RECEIVED

3. Carrier Common Line Access Service (Cont'd)

JAN 15 1997

3.7 Rate Regulations (Cont'd)

(F) (Cont'd)

MISSOURI

(5) If the required documentation is ~~Public Service Commission~~ Telephone Company, as described in 3.4.F., preceding for any subsequent month, no adjustment or credit will be made until the required documentation is delivered to the Telephone company by the customer.

(G) When the customer report interstate and intrastate use of Switched Access Service, the intrastate Switched Access Service access minutes will be billed interLATA or intraLATA Carrier Common Line Charges based on the date reported by the customer as set forth in 2.3.14 (A) and 2.3.15. The appropriate intrastate Switched Access Service access minutes will, after adjustment as set forth in 3.7.F preceding, when necessary, be used to determine the Carrier Common Line Charges.

3.8 Rates and Charges

The rate for interLATA Carrier Common Line Access is:

	Rate Per Access Minute	
- Terminating	\$.083479	(R)
- Originating	\$.044100	

The rate for intraLATA Carrier Common Line Access is:

	Rate Per Access Minute	
- Terminating	\$.084194	(R)
- Originating	\$.046800	

CANCELLED

JUN 30 1997  
By 3rd P.S. #107  
Public Service Commission  
MISSOURI

FILED

APR 15 1997

ISSUED:  
January 15, 1997

BY: John L. Roe  
VP - Carrier and Regulatory Services  
5454 West 110th Street  
Overland Park, Kansas 66211

MISSOURI PUBLIC SERVICE COMMISSION  
APR 15 1997

RECEIVED

ACCESS SERVICE

NOV 2 1993

3. Carrier Common Line Access Service

MO. PUBLIC SERVICE COMM.

3.7 Rate Regulations (Cont'd)

(F) (Cont'd)

(5) If the required documentation is not received by the Telephone Company, as described in 3.4.F. preceding, for any subsequent month, no adjustment or credit will be made until the required documentation is delivered to the Telephone company by the customer. (Z)

(G) When the customer reports interstate and intrastate use of Switched Access Service, the intrastate Switched Access Service access minutes will be billed interLATA or intraLATA Carrier Common Line Charges based on the data reported by the customer as set forth in 2.3.14 (A) and 2.3.15. The appropriate intrastate Switched Access Service access minutes will, after adjustment as set forth in 3.7.F preceding, when necessary, be used to determine the Carrier Common Line Charges. (Z)

3.8 Rates and Charges

The rate for interLATA Carrier Common Line Access is:

	Rate Per Access Minute	
-Terminating	\$.085000	(R)
-Originating	\$.044100	(R)

The rate for intraLATA Carrier Common Line Access is:

	Rate Per Access Minute	
-Terminating	\$.085715	(R)
-Originating	\$.046800	(R)

CANCELLED

APR 15 1997  
BY 2nd R.S. # 107  
Public Service Commission  
MISSOURI

FILED

NOV 7 1993  
93 - 181  
MO. PUBLIC SERVICE COMM.

ISSUED:  
November 3, 1993

BY: John L. Roe  
Vice President - Administration  
5454 West 110th Street  
Overland Park, Kansas 66211

EFFECTIVE:  
November 7, 1993

UNITED TELEPHONE COMPANY  
OF MISSOURI

Original Page 107

RECEIVED

SEP 17 1992

MISSOURI  
Public Service Commission

ACCESS SERVICE

3. Carrier Common Line Access Service (Cont'd)

3.7 Rate Regulations (Cont'd)

(F) (Cont'd)

(5) If the required documentation is not received by the Telephone Company, as described in 3.4.F., preceding for any subsequent month, no adjustment or credit will be made until the required documentation is delivered to the Telephone company by the customer.

(G) When the customer report interstate and intrastate use of Switched Access Service, the intrastate Switched Access Service access minutes will be billed interLATA or intraLATA Carrier Common Line Charges based on the date reported by the customer as set forth in 2.3.14 (A) and 2.3.15. The appropriate intrastate Switched Access Service access minutes will, after adjustment as set forth in 3.7.F preceding, when necessary, be used to determine the Carrier Common Line Charges.

3.8 Rates and Charges

The rate for interLATA Carrier Common Line Access is:

Premium Access, per minute

-Terminating	\$ .0900
-Originating	\$ .0547

The rate for intraLATA Carrier Common Line Access is:

Premium Access, per minute

-Terminating	\$ .085715
-Originating	\$ .052095

CANCELLED

NOV 7 1993  
BY *lat R.S. #109*  
Public Service Commission  
MISSOURI

FILED

NOV 7 1992

MO. PUBLIC SERVICE COMM.  
EFFECTIVE:

~~October 17, 1992~~

NOV 7 1992

ISSUED:  
September 17, 1992

BY: John L. Roe  
Vice President Administration  
5454 West 110th Street  
Overland Park, Kansas, 66211

UNITED TELEPHONE  
OF MISSOURI

Original Page 108

ACCESS SERVICE

RECEIVED

4. Reserved For Future Use

SEP 17 1992

MISSOURI  
PUBLIC SERVICE COMMISSION

ISSUED:  
September 17, 1992

BY: John L. Roe  
Vice President - Administration  
5454 West 110th Street  
Overland Park, Kansas 66211

FILED

NOV 7 1992

MO. PUBLIC SERVICE COMMISSION  
EFFECTIVE:

~~October 17, 1992~~

NOV 7 1992

## ACCESS SERVICE

### 5. Ordering Options for Switched and Special Access Service

#### 5.1 General

This section sets forth the regulations and order related charges for Access Orders for Switched and Special Access Services. These charges are in addition to other applicable charges as set forth in other sections of this tariff.

An Access Order is an order to provide the customer with Switched Access Service or Special Access Service or to provide changes to existing services.

#### 5.1.1 Ordering Conditions

A customer may order any number of services of the same type and between the same premises on a single Access Order. All details for services for a particular order must be identical except for those for multipoint service.

The customer shall provide all information necessary for the Telephone Company to provide and bill for the requested service. In addition to the order information required in 5.2 following, the customer must also provide:

- Customer name and premises address(es).
- Billing name and address (when different from customer name and address).
- Customer's contact name(s) and telephone number(s) for the following provisioning activities: order negotiation, order confirmation, interactive design, installation and billing.

Orders for Feature Group A Switched Access Service shall be in lines.

Orders for Feature Group B Switched Access Service shall be in trunks.

ISSUED:  
March 30, 2007

Mark D. Harper  
Director - State Regulatory  
5454 W. 110th Street  
Overland Park, Kansas 66211

EFFECTIVE:  
April 30, 2007

CANCELED  
July 1, 2012  
Missouri Public  
Service Commission  
TT-2012-0317, YI-2012-0635

**Filed**  
Missouri Public  
Service Commission

RECEIVED

SEP 17 1992

ACCESS SERVICE

5. Ordering Options for Switched and Special Access Service

5.1 General

This section sets forth the regulations and order related charges for Access Orders for Switched and Special Access Services. These charges are in addition to other applicable charges as set forth in other sections of this tariff.

An Access Order is an order to provide the customer with Switched Access Service or Special Access Service or to provide changes to existing services.

5.1.1 Ordering Conditions

A customer may order any number of services of the same type and between the same premises on a single Access Order. All details for services for a particular order must be identical except for those for multipoint service.

The customer shall provide all information necessary for the Telephone Company to provide and bill for the requested service. In addition to the order information required in 5.2 following, the customer must also provide:

- Customer name and premises address(es).
- Billing name and address (when different from customer name and address).
- Customer's contact name(s) and telephone number(s) for the following provisioning activities: order negotiation, order confirmation, interactive design, installation and billing.

Orders for Feature Group A Switched Access Service shall be in lines.

Orders for Feature Group B Switched Access Service shall be in trunks.

ISSUED:  
September 17, 1992

BY: John L. Roe  
Vice President - Administration  
5454 West 110th Street  
Overland Park, Kansas 66211

EFFECTIVE:

NOV 7 1992

Cancelled  
April 30, 2007  
Missouri Public  
Service Commission



UNITED TELEPHONE COMPANY  
OF MISSOURI

Original Page 110

RECEIVED

SEP 17 1992

## ACCESS SERVICE

5. Ordering Options for Switched and Special Access Service (Cont'd)

5.1 General (Cont'd)

5.1.1 Ordering Conditions (Cont'd)

The order date, which is known as the Application Date, is the date on which the Telephone Company receives a firm commitment and sufficient information from the customer to allow processing of the Access Order. The customer is advised of the Application Date at the time the Telephone Company gives the customer a firm order confirmation.

5.1.2 Provision of Other Services

- (A) Testing Service, Additional Labor, Restoration Priority and Special Facilities Routing may be ordered with an Access Order or as set forth in (B) following. The rates and charges for these services, as set forth in other sections of this tariff, will apply in addition to the ordering charges set forth in this section and the rates and charges for the Access Service with which they are associated.
- (B) With the agreement of the Telephone Company, the items listed in (A) preceding may subsequently be added to the order at any time, up to and including the service date for an Access Service. When added subsequently, charges for a design change as set forth in 5.2.2(C) following will apply when an engineering review is required.
- (C) Additional Engineering is not an ordering option, but will be applied to an Access Order when the Telephone Company determines that Additional Engineering is necessary to accommodate a customer request. Additional Engineering will only be required as set forth in 13.1 following. When it is required, the customer will be so notified and will be furnished with a written statement setting forth the justification for the Additional Engineering as well as an estimate of the charges. If the customer agrees to the Additional Engineering, a firm order will be established. If the customer does not want the service or facilities after being notified that Additional Engineering

ISSUED:  
September 17, 1992

BY: John L. Roe  
Vice President - Administration  
5454 West 110th Street  
Overland Park, Kansas 66211

EFFECTIVE:

~~October 17, 1992~~

NOV 7 1992

Cancelled

April 30, 2007  
Missouri Public  
Service Commission



ACCESS SERVICE

5. Ordering Options for Switched and Special Access Service (Cont'd)

5.1 General (Cont'd)

5.1.2 Provision of Other Services (Cont'd)

(C) (Cont'd)

of Telephone Company facilities is required, the order will be withdrawn and no charges will apply. Once a firm order has been established, the total charge to the customer for the Additional Engineering may not exceed the estimated amount by more than 10%.

The regulations, rates and charges for Additional Engineering are as set forth in 13.1 following and are in addition to the regulations, rates and charges specified in this section.

5.1.3 Special Construction

The regulations, rates and charges for special construction are set forth in Section 14. following, and are in addition to the regulations, rates and charges specified in this section.

5.2 Access Order

An Access Order is used by the Telephone Company to provide a customer Access Service as follows:

- Switched Access Services as set forth in 6. following,
- Special Access Services as set forth in 7. following, and
- Other Services as set forth in 5.1.2 preceding.

When placing an order for Access Service, the customer shall provide, at a minimum, the following information:

- For Feature Group A Switched Access Service, the customer shall specify the number of lines and the first point of switching (i.e., dial tone office), the directionality of the service and the Local Transport and Local Switching options desired. In addition, the customer shall also specify which lines are to be arranged in multiline hunt group arrangements and which lines are to be provided as single lines.

ISSUED:  
March 30, 2007

Mark D. Harper  
Director - State Regulatory  
5454 W. 110th Street  
Overland Park, Kansas 66211

EFFECTIVE:  
April 30, 2007

CANCELED  
July 1, 2012  
Missouri Public  
Service Commission  
TT-2012-0317, YI-2012-0635

**Filed**  
Missouri Public  
Service Commission

RECEIVED

SEP 17 1992

ACCESS SERVICE

5. Ordering Options for Switched and Special Access Service (Cont'd)

5.1 General (Cont'd)

5.1.2 Provision of Other Services (Cont'd)

(C) (Cont'd)

of Telephone Company facilities is required, the order will be withdrawn and no charges will apply. Once a firm order has been established, the total charge to the customer for the Additional Engineering may not exceed the estimated amount by more than 10%.

The regulations, rates and charges for Additional Engineering are as set forth in 13.1 following and are in addition to the regulations, rates and charges specified in this section.

5.1.3 Special Construction

The regulations, rates and charges for special construction are set forth in Section 14. following, and are in addition to the regulations, rates and charges specified in this section.

5.2 Access Order

An Access Order is used by the Telephone Company to provide a customer Access Service as follows:

- Switched Access Services as set forth in 6. following,
- Special Access Services as set forth in 7. following, and
- Other Services as set forth in 5.1.2 preceding.

When placing an order for Access Service, the customer shall provide, at a minimum, the following information:

- For Feature Group A Switched Access Service, the customer shall specify the number of lines and the first point of switching (i.e., dial tone office), the directionality of the service and the Local Transport and Local Switching options desired. In addition, the customer shall also specify which lines are to be arranged in multiline hunt group arrangements and which lines are to be provided as single lines.

NOV 7 1992

ISSUED:  
September 17, 1992

BY: John L. Roe  
Vice President - Administration  
5454 West 110th Street  
Overland Park, Kansas 66211

EFFECTIVE:  
~~October 1, 1992~~  
NOV 7 1992

ACCESS SERVICE

5. Ordering Options for Switched and Special Access Service (Cont'd)

5.2 Access Order (Cont'd)

The customer shall also specify that the Feature Group A is to be provided with an extension to a different exchange, if applicable. When such an extension is specified on the order, the customer must also specify the customer's premises in the different exchange with the Switched Access Feature Group A, at which the FGA extension is to be terminated.

- For Feature Group B Switched Access Service, the customer shall specify the number of trunks and the end office when direct routing to the end office is desired or the access tandem switch when routing is desired via an access tandem switch and Local Transport options and Local Switching options desired. When ordering FGB trunks to an access tandem, the customer must also provide the Telephone Company an estimate of the amount of traffic it will generate to and/or from each end office subtending the access tandem to assist the Telephone Company in its own efforts to project further facility requirements. In addition, the customer shall also specify for terminating only access minutes whether the trunks are to be arranged in trunk group arrangements or provided as single trunks. The traffic type must also be specified using the same categories as described in 6.1.1(E) following, to enable efficient provisioning and billing functions.
- For Feature Group C and D Switched Access Service, the customer shall specify the number of trunks and the end office when direct routing to the end office is desired or the access tandem switch when routing is desired via an access tandem switch and the Local Transport and Local Switching options desired. When ordering FGC or FGD trunks to an access tandem, the customer must also provide the Telephone Company an estimate of the amount of traffic by type it will generate to and/or from each end office subtending the access tandem to assist the Telephone Company in its own efforts to project further facility requirements. The basic traffic type must also be specified using the same categories as described in 6.1.1(E) following, to enable efficient provisioning and billing functions. When a customer orders FGD, the customer is responsible to assure that sufficient access facilities have been ordered to handle its traffic.

ISSUED:  
March 30, 2007

Mark D. Harper  
Director - State Regulatory  
5454 W. 110th Street  
Overland Park, Kansas 66211

EFFECTIVE:  
April 30, 2007

CANCELED  
July 1, 2012  
Missouri Public  
Service Commission  
TT-2012-0317, YI-2012-0635

**Filed**  
Missouri Public  
Service Commission



SPRINT MISSOURI, INC.  
d/b/a SPRINT

First Revised Page 112  
Cancels Original Page 112  
Missouri Public

ACCESS SERVICE

5. Ordering Options for Switched and Special Access Service (Cont'd)

REC'D JAN 07 2002

5.2 Access Order (Cont'd)

Service Commission

The customer shall also specify that the Feature Group A is to be provided with an extension to a different exchange, if applicable. When such an extension is specified on the order, the customer must also specify the customer's premises in the different exchange with the Switched Access Feature Group A, at which the FGA extension is to be terminated.

For Feature Group B Switched Access Service, the customer shall specify the number of trunks and the end office when direct routing to the end office is desired or the access tandem switch when routing is desired via an access tandem switch and Local Transport options and Local Switching options desired. When ordering FGB trunks to an access tandem, the customer must also provide the Telephone Company an estimate of the amount of traffic it will generate to and/or from each end office subtending the access tandem to assist the Telephone Company in its own efforts to project further facility requirements. In addition, the customer shall also specify for terminating only access minutes whether the trunks are to be arranged in trunk group arrangements or provided as single trunks. The traffic type must also be specified using the same categories as described in 6.1.1(E) following, to enable efficient provisioning and billing functions.

For Feature Group C and D Switched Access Service, the customer shall specify the number **of trunks and the end office when direct routing to the end office is desired or the access tandem switch when routing is desired via an access tandem switch and the Local Transport and Local Switching options desired. When ordering FGC or FGD trunks to an access tandem, the customer must also provide the Telephone Company an estimate of the amount of traffic by type it will generate to and/or from each end office subtending the access tandem to assist the Telephone Company in its own efforts to project further facility requirements. The basic traffic type must also be specified using the same categories as described in 6.1.1(E) following, to enable efficient provisioning and billing functions. When a customer orders FGD, the customer is responsible to assure that sufficient access facilities have been ordered to handle its traffic.**

(C)

(C)

(D)

(D)

Missouri Public

FILED FEB 07 2002

Service Commission

ISSUED:  
January 7, 2002

Richard D. Lawson  
State Executive, External Affairs  
319 Madison  
Jefferson City, MO 65101

EFFECTIVE:  
February 7, 2002

Cancelled

April 30, 2007  
Missouri Public  
Service Commission

UNITED TELEPHONE COMPANY  
OF MISSOURI

Original Page 112

RECEIVED

SEP 17 1992

ACCESS SERVICE

5. Ordering Options for Switched and Special Access Service (Cont'd)

MISSOURI  
Public Service Commission

5.2 Access Order (Cont'd)

The customer shall also specify that the Feature Group A is to be provided with an extension to a different exchange, if applicable. When such an extension is specified on the order, the customer must also specify the customer's premises in the different exchange with the Switched Access Feature Group A, at which the FGA extension is to be terminated.

- For Feature Group B Switched Access Service, the customer shall specify the number of trunks and the end office when direct routing to the end office is desired or the access tandem switch when routing is desired via an access tandem switch and Local Transport options and Local Switching options desired. When ordering FGB trunks to an access tandem, the customer must also provide the Telephone Company an estimate of the amount of traffic it will generate to and/or from each end office subtending the access tandem to assist the Telephone Company in its own efforts to project further facility requirements. In addition, the customer shall also specify for terminating only access minutes whether the trunks are to be arranged in trunk group arrangements or provided as single trunks. The traffic type must also be specified using the same categories as described in 6.1.1(E) following, to enable efficient provisioning and billing functions.

- For Feature Group C and D Switched Access Service, the customer shall specify the number of busy hour minutes of capacity (BHMC) from the customer's premises to the end office by Feature Group and traffic type. This information is used to determine the number of transmission paths as set forth in 6.5.5 following. The customer shall also specify the Local Transport and Local Switching options.

CANCELLED

FEB 07 2002 -

15/RP/112

Public Service Commission  
MISSOURI

Customers other than AT&T may, at their option, order FGD by specifying the number of trunks and the end office when direct routing to the end office is desired or the access tandem switch when routing is desired via an access tandem and the Local Transport and Local Switching Options desired. When ordering by trunk quantities rather than BHMC quantities to an access tandem, the customer must also provide the Telephone Company an estimate of the amount of traffic by type it will generate to and/or from each end office subtending the access tandem to assist the Telephone Company in its own efforts to project further facility requirements. The basic type must be specified using:

NOV 7 1992

NO. PUBLIC SERVICE COMMISSION

ISSUED:  
September 17, 1992

BY: John L. Roe  
Vice President - Administration  
5454 West 110th Street  
Overland Park, Kansas 66211

EFFECTIVE:  
~~September 17, 1992~~  
NOV 7 1992

ACCESS SERVICE

5. Ordering Options for Switched and Special Access Service (Cont'd)

5.2 Access Order (Cont'd)

- the same categories as described in 6.1.1(E) following, to enable efficient provisioning and billing functions. When a customer orders FGD, the customer is responsible to assure that sufficient access facilities have been ordered to handle its traffic.
  
- For all Special Access Services, the customer must specify the customer designated premises or Hubs involved, the type of service (e.g., Video, Voice Grade, High Capacity, etc.), the channel interface, technical specification package and options desired. For multipoint services, the channel interface at each premises may, at the request of the customer, be different but all such interfaces shall be compatible.

ISSUED:  
March 30, 2007

Mark D. Harper  
Director - State Regulatory  
5454 W. 110th Street  
Overland Park, Kansas 66211

EFFECTIVE:  
April 30, 2007

CANCELED  
July 1, 2012  
Missouri Public  
Service Commission  
TT-2012-0317, YI-2012-0635

SPRINT MISSOURI, INC.  
d/b/a SPRINT

First Revised Page 113  
Cancels Original Page 113  
Missouri Public

ACCESS SERVICE

REC'D JAN 07 2002

5. Ordering Options for Switched and Special Access Service (Cont'd)

Service Commission

5.2 Access Order (Cont'd)

- the same categories as described in 6.1.1(E) following, to enable efficient provisioning and billing functions. When a customer orders **FGD**, the customer is responsible to assure that sufficient access facilities have been ordered to handle its traffic.

(C)

(D)

(D)

For all Special Access Services, the customer must specify the customer designated premises or Hubs involved, the type of service (e.g., Video, Voice Grade, High Capacity, etc.), the channel interface, technical specification package and options desired. For multipoint services, the channel interface at each premises may, at the request of the customer, be different but all such interfaces shall be compatible.

Missouri Public

FILED FEB 07 2002

Service Commission

ISSUED:  
January 7, 2002

Richard D. Lawson  
State Executive, External Affairs  
319 Madison  
Jefferson City, MO 65101

EFFECTIVE:  
February 7, 2002

UNITED TELEPHONE COMPANY  
OF MISSOURI

RECEIVED

SEP 17 1992

ACCESS SERVICE

5. Ordering Options for Switched and Special Access Service (Cont'd)

MISSOURI  
Public Service Commission

5.2 Access Order (Cont'd)

- the same categories as described in 6.1.1(E) following, to enable efficient provisioning and billing functions.

When a customer orders FGD in trunks, the customer is responsible to assure that sufficient access facilities have been ordered to handle its traffic. When a customer orders in BHMC quantities, the Telephone Company assumes the traffic engineering responsibility and will determine the facilities required to meet the customers BHMC requirement. Since only one party can carry out the requisite engineering, a customer cannot order some FGD Access in BHMCs and other FGD Access in trunks in the same exchange. If a customer wishes to convert its ordering basis in the exchange from trunks to BHMCs or BHMCs to trunks, the Telephone Company will work cooperatively with the customer to make the conversion.

- For all Special Access Services, the customer must specify the customer designated premises or Hubs involved, the type of service (e.g., Video, Voice Grade, High Capacity, etc.), the channel interface, technical specification package and options desired. For multipoint services, the channel interface at each premises may, at the request of the customer, be different but all such interfaces shall be compatible.

CANCELLED

FEB 07 2002

By 157 RP 113  
Public Service Commission  
MISSOURI

FILED

NOV 7 1992

MO. PUBLIC SERVICE COMMISSION

EFFECTIVE:

~~September 7, 1992~~

NOV 7 1992

ISSUED:  
September 17, 1992

BY: John L. Roe  
Vice President - Administration  
5454 West 110th Street  
Overland Park, Kansas 66211



SPRINT MISSOURI, INC.  
d/b/a SPRINT

Third Revised Page 114  
Cancels Second Revised Page 114

Missouri Public

ACCESS SERVICE

REC'D JAN 07 2002

5. Ordering Options for Switched and Special Access Service (Cont'd)

Service Commission

5.2 Access Order (Cont'd)

- When a customer desires Switched Access Service to an end office that is a remote switching office, the customer must order to the host office which controls the remote switching office since all traffic to and/or from a remote switching office must be routed through the host office.
- For WATS Access Line Service the customer must also specify the type of calling (i.e., originating only or terminating only) for which the service is to be provided, the type of WAL (i.e., interLATA only or jointly provisioned WAL), the TFC telephone number the customer has assigned to the terminating WATS Access Line Service, the type of address signaling and the type of supervisory signaling. When WATS Access Line Service is ordered for use in terminating TFC Access Service traffic, the customer shall specify the Switched Access Feature Group that will carry this terminating traffic. When Feature Group A (FGA) access is used in conjunction with WATS Access Line Service, the customer must also identify the FGA seven digit local telephone number used to complete the TFC Access Service calls. Additionally, when the necessary screening functions are not provided at the wire center which serves the customer's originating or terminating premises, the Telephone Company will provide the service to the nearest wire center where capacity exists. In these circumstances, the customer will be so notified and the order will be changed to designate the appropriate premises. No charge will apply for the change. In addition, the customer must specify that the WATS Access Line is to be provided with an extension in the same or a different LATA, if applicable. When such an extension is specified, the customer must provide either (1) the end user premises (for an intraLATA extension) or (2) the customer-designated premises (for an extension in a different LATA) to which the extension is to be provided.
- For **Toll Free Code (TFC)** Access Service, the customer shall order in the same manner which is set forth preceding for ordering Feature Group D, except that customers may request direct connections to only those end offices and access tandems equipped with TFC Service Switching Point (TFC SSP) functionality. All TFC traffic originating from end offices not equipped with the TFC SSP function must be routed via an access tandem at which the function is available and the TFC Access Service must be ordered accordingly. TFC SSP locations are identified in the National Exchange Carrier Association, Inc. Tariff F.C.C. No. 4. The TFC Access Service customer must advise its Responsible Organization or the TFC Service Management System (TFC SMS) whether the TFC to Local Exchange Number Translation optional (T)

Missouri Public

FILED FEB 07 2002

Service Commission

ISSUED:  
January 7, 2002

Richard D. Lawson  
State Executive, External Affairs  
319 Madison  
Jefferson City, MO 65101

EFFECTIVE:  
February 7, 2002

Cancelled

April 30, 2007

Missouri Public

Service Commission

UNITED TELEPHONE COMPANY  
OF MISSOURI

Second Revised Page 114  
Cancels First Revised Page 114

RECEIVED

ACCESS SERVICE

MAR 27 1996

5. Ordering Options for Switched and Special Access Service (Cont'd)

MISSOURI  
Public Service Commission

5.2 Access Order (Cont'd)

- When a customer desires Switched Access Service to an end office that is a remote switching office, the customer must order to the host office which controls the remote switching office since all traffic to and/or from a remote switching office must be routed through the host office.
- For WATS Access Line Service the customer must also specify the type of calling (i.e., originating only or terminating only) for which the service is to be provided, the type of WAL (i.e., interLATA only or jointly provisioned WAL), the TFC telephone number the customer has assigned to the terminating WATS Access Line Service, the type of address signaling and the type of supervisory signaling. When WATS Access Line Service is ordered for use in terminating TFC Access Service traffic, the customer shall specify the Switched Access Feature Group that will carry this terminating traffic. When Feature Group A (FGA) access is used in conjunction with WATS Access Line Service, the customer must also identify the FGA seven digit local telephone number used to complete the TFC Access Service calls. Additionally, when the necessary screening functions are not provided at the wire center which serves the customer's originating or terminating premises, the Telephone Company will provide the service to the nearest wire center where capacity exists. In these circumstances, the customer will be so notified and the order will be changed to designate the appropriate premises. No charge will apply for the change. In addition, the customer must specify that the WATS Access Line is to be provided with an extension in the same or a different LATA, if applicable. When such an extension is specified, the customer must provide either (1) the end user premises (for an intraLATA extension) or (2) the customer-designated premises (for an extension in a different LATA) to which the extension is to be provided. (T)
- For TFC Access Service, the customer shall order in the same manner which is set forth preceding for ordering Feature Group D, except that customers may request direct connections to only those end offices and access tandems equipped with TFC Service Switching Point (TFC SSP) functionality. All TFC traffic originating from end offices not equipped with the TFC SSP function must be routed via an access tandem at which the function is available and the TFC Access Service must be ordered accordingly. TFC SSP locations are identified in the National Exchange Carrier Association Tariff F.C.C. No. 4. The TFC Access Service customer must advise its Responsible Organization or the TFC Service Management System (TFC SMS) whether the TFC to Local Exchange Number Translation optional (T)

CANCELLED

FEB 07 2002

3M R P 114

Public Service Commission  
MISSOURI

APR 29 1996

MO. PUBLIC SERVICE COMM.

ISSUED:  
March 27, 1996

BY: John L. Roe  
Vice President - Carrier and Regulatory Services  
5454 West 110th Street  
Overland Park, Kansas 66211

EFFECTIVE:  
April 29, 1996

ACCESS SERVICE

5. Ordering Options for Switched and Special Access Service (Cont'd)

RECEIVED

MAR 31 1993

5.2 Access Order (Cont'd)

- When a customer desires Switched Access Service to an end office that is a remote switching office, the customer must order to the host office which controls the remote switching office since all traffic to and/or from a remote switching office must be routed through the host office.
- For WATS Access Line Service the customer must also specify the type of calling (i.e., originating only or terminating only) for which the service is to be provided, the type of WAL (i.e., interLATA only or jointly provisioned WAL), the 800 telephone number the customer has assigned to the terminating WATS Access Line Service, the type of address signaling and the type of supervisory signaling. When WATS Access Line Service is ordered for use in terminating 800 Access Service traffic, the customer shall specify the Switched Access Feature Group that will carry this terminating traffic. When Feature Group A (FGA) access is used in conjunction with WATS Access Line Service, the customer must also identify the FGA seven digit local telephone number used to complete the 800 Access Service calls. Additionally, when the necessary screening functions are not provided at the wire center which serves the customer's originating or terminating premises, the Telephone Company will provide the service to the nearest wire center where capacity exists. In these circumstances, the customer will be so notified and the order will be changed to designate the appropriate premises. No charge will apply for the change. In addition, the customer must specify that the WATS Access Line is to be provided with an extension in a different LATA, if applicable. When such an extension is specified, the customer must provide either (1) the end user premises (for an intraLATA extension) or (2) the customer designated premises (for an extension in a different LATA) to which the extension is to be provided.
- For 800 Access Service, the customer shall order in the manner which is set forth preceding for ordering Feature Group D, except that customers may request direct connections to only those end offices and access tandems equipped with 800 Service Switching Point (800 SSP) functionality. All 800 traffic originating from end offices not equipped with the 800 SSP function must be routed via an access tandem at which the function is available and the 800 Access Service must be ordered accordingly. 800 SSP locations are identified in the National Exchange Carrier Association Tariff F.C.C. No. 4. The 800 Access Service customer must advise its Responsible Organization or the 800 Service Management System (800 SMS) whether the 800 to Local Exchange Number Translation optional

CANCELLED

APR 29 1996  
BY 2nd R.S #114  
Public Service Commission  
MISSOURI

MAY 01 1993

ISSUED:  
March 31, 1993

BY: John L. Roe  
Vice President - Administration  
5454 West 110th Street  
Overland Park, Kansas 66211

MO. PUBLIC SERVICE COMMISSION  
EFFECTIVE:  
May 1, 1993

UNITED TELEPHONE COMPANY  
OF MISSOURI

Original Page 114

RECEIVED

SEP 17 1992

ACCESS SERVICE

5. Ordering Options for Switched and Special Access Service (Cont'd)

MISSOURI  
Public Service Commission

5.2 Access Order (Cont'd)

- When a customer desires Switched Access Service to an end office that is a remote switching office, the customer must order to the host office which controls the remote switching office since all traffic to and/or from a remote switching office must be routed through the host office.
- For WATS Access Line Service the customer must also specify the type of calling (i.e., originating only or terminating only) for which the service is to be provided, the type of WAL (i.e., interLATA only or jointly provisioned WAL), the 800 telephone number the customer has assigned to the terminating WATS Access Line Service, the type of address signaling and the type of supervisory signaling. When WATS Access Line Service is ordered for use in terminating 800 Access Service traffic, the customer shall specify the Switched Access Feature Group that will carry this terminating traffic. When Feature Group A (FGA) access is used in conjunction with WATS Access Line Service, the customer must also identify the FGA seven digit local telephone number used to complete the 800 Access Service calls. Additionally, when the necessary screening functions are not provided at the wire center which serves the customer's originating or terminating premises, the Telephone Company will provide the service to the nearest wire center where capacity exists. In these circumstances, the customer will be so notified and the order will be changed to designate the appropriate premises. No charge will apply for the change. In addition, the customer must specify that the WATS Access Line is to be provided with an extension in the same or a different LATA, if applicable. When such an extension is specified, the customer must provide either (1) the end user premises (for an intraLATA extension) or (2) the customer-designated premises (for an extension in a different LATA) to which the extension is to be provided.

CANCELLED

MAY 1 1993  
BY lat R.S #114  
Public Service Commission  
MISSOURI

FILED

NOV 7 1992

MO. PUBLIC SERVICE COMMISSION

ISSUED:  
September 17, 1992

BY: John L. Roe  
Vice President - Administration  
5454 West 110th Street  
Overland Park, Kansas 66211

EFFECTIVE:

~~September 17, 1992~~

NOV 7 1992



SPRINT MISSOURI, INC  
d/b/a SPRINT

Fourth Revised Page 115  
Cancels Third Revised Page 115

Missouri Public

ACCESS SERVICE

5. Ordering Options for Switched and Special Access Service (Cont'd)

REC'D JAN 07 2002

5.2 Access Order (Cont'd)

Service Commission

feature set forth in Section 6.2.5 following is desired. When the TFC to Local Exchange Number Translation feature is to be delivered to the customer, the customer must provide, via the TFC record in the TFC SMS, the ten digit local exchange number (NPA-NXX-XXXX) to be associated with the translated TFC number. If the TFC to Local Exchange Number Translation optional feature is used, the customer will be unable to determine that such calls originated as 1+TFC-NXX-XXXX dialed calls unless the customer also orders the Flexible Automatic Number Identification (Flex ANI) optional feature.

In addition, when a local exchange number is to be delivered to the TFC Access Service customer, the customer must provide to its Responsible Organization or to the TFC Service Management System (TFC SMS), the ten digit local exchange number to be associated with the translated TFC number.

If the customer desires any of the TFC Data Base Optional Service Features described in Section 6.2.5, the customer must enter this information into the TFC SMS or provide the information to its Responsible Organization for handling. Optional features are not available to customers of interexchange carriers for use in connection with interLATA TFC services.

For Interim 500 or 900 Access Service, the customer shall order in the same manner which is set forth preceding for ordering Feature Group D, except that customers may request direct connections to only those end offices designated by the Telephone Company as Interim 500 or 900 Access Service screening offices. Additionally, when new NXX(s) are to be opened in the state, for exchanges served by the Telephone Company, or when existing NXX(s) are to be deleted, and such change is to occur coincident with the service date established for the order, the customer shall provide such information when placing the order for service. If the change is to occur absent the requirement for additional capacity (i.e., quantities of trunks), the customer shall notify the Telephone Company of the change as set forth in 6.6.1(C) and 6.6.1(D) following. All 500 or 900 number assignments and administration shall be in accordance with the North American Numbering Plan (NANP).

Missouri Public

FILED FEB 07 2002

Service Commission

When Switched Access Service is ordered in trunks, the trunks may be determined by the customer in the following manner. For each day the customer shall determine the highest number of trunks in use for a single hour. The customer shall, for the same hour period (i.e., busy hour), pick the twenty consecutive business days in a

ISSUED:  
January 7, 2002

Richard D. Lawson  
State Executive, External Affairs  
319 Madison  
Jefferson City, MO 65101

EFFECTIVE:  
February 7, 2002

Cancelled

April 30, 2007  
Missouri Public  
Service Commission

(D)  
|  
(D)

ACCESS SERVICE

RECEIVED

5. Ordering Options for Switched and Special Access Service (Cont'd)

5.2 Access Order (Cont'd)

MAR 27 1996

feature set forth in Section 6.2.5 following is desired. When the TFC to Local Exchange Number Translation feature is delivered to the customer, the customer must have a record in the TFC SMS, the ten digit local exchange number (NPA-NXX-XXXX) to be associated with the translated TFC number. If the TFC to Local Exchange Number Translation optional feature is used, the customer will be unable to determine that such calls originated as 1+TFC-NXX-XXXX dialed calls unless the customer also orders the Flexible Automatic Number Identification (Flex ANI) optional feature.

(T)  
|  
(T)  
(T)

In addition, when a local exchange number is to be delivered to the TFC Access Service customer, the customer must provide to its Responsible Organization or to the TFC Service Management System (TFC SMS), the ten digit local exchange number to be associated with the translated TFC number.

(T)  
|  
(T)

If the customer desires any of the TFC Data Base Optional Service Features described in Section 6.2.5, the customer must enter this information into the TFC SMS or provide the information to its Responsible Organization for handling. Optional features are not available to customers of interexchange carriers for use in connection with interLATA TFC services.

(T)  
(T)  
(T)

For Interim 500 or 900 Access Service, the customer shall order in the same manner which is set forth preceding for ordering Feature Group D, except that customers may request direct connections to only those end offices designated by the Telephone Company as Interim 500 or 900 Access Service screening offices. Additionally, when new NXX(s) are to be opened in the state, for exchanges served by the Telephone Company, or when existing NXX(s) are to be deleted, and such change is to occur coincident with the service date established for the order, the customer shall provide such information when placing the order for service. If the change is to occur absent the requirement for additional capacity (i.e., quantities of trunks), the customer shall notify the Telephone Company of the change as set forth in 6.6.1(C) and 6.6.1(D) following. All 500 or 900 number assignments and administration shall be in accordance with the North American Numbering Plan (NANP).

When Switched Access Service is ordered in BHMC, the BHMC may be determined by the customer in the following manner. For each day, the customer shall determine the highest number of minutes of use for a single hour (e.g., 55 minutes in the 10-11 AM hour). The customer shall, for the same hour period (i.e., busy hour), pick the twenty consecutive business days in a calendar year which add up to the largest number of minutes of use. Both originating and terminating minutes shall be included on two way groups. The customer shall then determine the average busy hour minutes of capacity (i.e., BHMC) by dividing the largest number of minutes of use figure for the same hour period for the consecutive twenty business day period by 20. This computation shall be performed for each end office the customer wishes to serve. When Switched Access Service is ordered in trunks, the trunks may be determined by the customer in the following manner. For each day the customer shall determine the highest number of trunks in use for a single hour. The customer shall, for the same hour period (i.e., busy hour), pick the twenty consecutive business days in a

CANCELLED

FEB 07 2002

11 44 R P 115  
Public Service Commission  
MISSOURI

ISSUED:  
March 27, 1996

BY: John L. Roe  
Vice President - Carrier and Regulatory Services  
5454 West 110th Street  
Overland Park, Kansas 66211

EFFECTIVE:  
April 29, 1996

ACCESS SERVICE

5. Ordering Options for Switched and Special Access Service RECEIVED

5.2 Access Order (Cont'd)

feature set forth in Section 6.2.5 following is desired. 1/11/85  
800 to Local Exchange Number Translation feature is to be  
delivered to the customer, the customer must provide, via the 800  
record in the 800 SMS, the ten digit local exchange number (NPA-  
NXX-XXXX) to be associated with the translated 800 number. If the  
800 to Local Exchange Number Translation optional feature is used,  
the customer will be unable to determine that such calls  
originated as 1+800-NXX-XXXX dialed calls unless the customer also  
orders the Flexible Automatic Number Identification (Flex ANI)  
optional feature.

In addition, when a local exchange number is to be delivered to  
the 800 Access Service customer, the customer must provide to its  
Responsible Organization or to the 800 Service Management System  
(800 SMS), the ten digit local exchange number to be associated  
with the translated 800 number.

If the customer desires any of the 800 Data Base Optional Service  
Features described in Section 6.2.5, the customer must enter this  
information into the 800 SMS or provide the information to its  
Responsible Organization for handling. Optional features are not  
available to customers of interexchange carriers for use in  
connection with interLATA 800 services.

For Interim 500 or 900 Access Service, the customer shall order in  
the same manner which is set forth preceding for ordering Feature  
Group D, except that customers may request direct connections to  
only those end offices designated by the Telephone Company as  
Interim 500 or 900 Access Service screening offices.  
Additionally, when new NXX(s) are to be opened in the state, for  
exchanges served by the Telephone Company, or when existing NXX(s)  
are to be deleted, and such change is to occur coincident with the  
service date established for the order, the customer shall provide  
such information when placing the order for service. CANCELLED  
change is to occur absent the requirement for additional capacity  
(i.e., quantities of trunks), the customer shall notify the  
Telephone Company of the change as set forth in 6.6.1(C) and  
6.6.1(D) following. All 500 or 900 number assignments  
administration shall be in accordance with the North American  
Numbering Plan (NANP).

When Switched Access Service is ordered in BHMC, the BHMC shall be  
determined by the customer in the following manner. For each day  
the customer shall determine the highest number of minutes of use  
for a single hour (e.g., 55 minutes in the 10-11 AM hour). The  
customer shall, for the same hour period (i.e., busy hour), pick  
the twenty consecutive business days in a calendar year which add  
up to the largest number of minutes of use. Both originating and  
terminating minutes shall be included on two way groups. The  
customer shall then determine the average busy hour minutes of  
capacity (i.e., BHMC) by dividing the largest number of minutes of  
use figure for the same hour period for the consecutive twenty  
business day period by 20. This computation shall be performed  
for each end office the customer wishes to serve. When Switched  
Access Service is ordered in trunks, the trunks may be determined  
by the customer in the following manner. For each day the  
customer shall determine the highest number of trunks in use for a  
single hour. The customer shall, for the same hour period (i.e.,  
busy hour), pick the twenty consecutive business days in a

FEB 11 1995

ISSUED:  
January 11, 1995

BY: John L. Roe  
Vice President - Carrier and Regulatory Services  
5454 West 110th Street  
Overland Park, Kansas 66211

EFFECTIVE:  
February 11, 1995  
Missouri Public Service Commission

ACCESS SERVICE

MAR 31 1993

5. Ordering Options for Switched and Special Access Service (Cont'd)

MO. PUBLIC SERVICE COM. (N)

5.2 Access Order (Cont'd)

feature set forth in Section 6.2.5 following is desired. When the 800 to Local Exchange Number Translation feature is to be delivered to the customer, the customer must provide, via the 800 record in the 800 SMS, the ten digit local exchange number (NPA-NXX-XXXX) to be associated with the translated 800 number. If the 800 to Local Exchange Number Translation optional feature is used, the customer will be unable to determine that such calls originated as 1+800-NXX-XXXX dialed calls unless the customer also orders the Flexible Automatic Number Identification (Flex ANI) optional feature.

In addition, when a local exchange number is to be delivered to the 800 Access Service customer, the customer must provide to its Responsible Organization or to the 800 Service Management System (800 SMS), the ten digit local exchange number to be associated with the translated 800 number.

If the customer desires any of the 800 Data Base Optional Service Features described in Section 6.2.5, the customer must enter this information into the 800 SMS or provide the information to its Responsible Organization for handling. Optional features are not available to customers of interexchange carriers for use in connection with interLATA 800 services. (N)

When Switched Access Service is ordered in BHMC, the BHMC may be determined by the customer in the following manner. For each day, the customer shall determine the highest number of minutes of use for a single hour (e.g., 55 minutes in the 10-11 AM hour). The customer shall, for the same hour period (i.e., busy hour), pick the twenty consecutive business days in a calendar year which add up to the largest number of minutes of use. Both originating and terminating minutes shall be included on two way groups. The customer shall then determine the average busy hour minutes of capacity (i.e., BHMC) by dividing the largest number of minutes of use figure for the same hour period for the consecutive twenty business day period by 20. This computation shall be performed for each end office the customer wishes to serve. When Switched Access Service is ordered in trunks, the trunks may be determined by the customer in the following manner. For each day the customer shall determine the highest number of trunks in use for a single hour. The customer shall, for the same hour period (i.e, busy hour), pick the twenty consecutive business days in a calendar year which add up to the largest number of trunks in use. The customer shall then determine the average busy hour trunks by dividing the largest number of trunks in use figure, for the same hour period, for the consecutive twenty business day period. This computation shall be performed for each end office and/or access tandem the customer wishes to serve.

CANCELLED

FEB 11 1995

MAY 01 1993

ISSUED:  
March 31, 1993

BY: John L. Boe  
Vice President - Administration  
5454 West 110th Street  
Overland Park, Kansas 66211

MO. PUBLIC SERVICE COM. EFFECTIVE  
May 1, 1993



UNITED TELEPHONE COMPANY  
OF MISSOURI

Original Page 115

RECEIVED

ACCESS SERVICE

SEP 17 1992

5. Ordering Options for Switched and Special Access Service (Cont'd)

MISSOURI  
Public Service Commission

5.2 Access Order (Cont'd)

When Switched Access Service is ordered in BHMC, the BHMC may be determined by the customer in the following manner. For each day, the customer shall determine the highest number of minutes of use for a single hour (e.g., 55 minutes in the 10-11 AM hour). The customer shall, for the same hour period (i.e., busy hour), pick the twenty consecutive business days in a calendar year which add up to the largest number of minutes of use. Both originating and terminating minutes shall be included on two way groups. The customer shall then determine the average busy hour minutes of capacity (i.e., BHMC) by dividing the largest number of minutes of use figure for the same hour period for the consecutive twenty business day period by 20. This computation shall be performed for each end office the customer wishes to serve. When Switched Access Service is ordered in trunks, the trunks may be determined by the customer in the following manner. For each day the customer shall determine the highest number of trunks in use for a single hour. The customer shall, for the same hour period (i.e., busy hour), pick the twenty consecutive business days in a calendar year which add up to the largest number of trunks in use. The customer shall then determine the average busy hour trunks by dividing the largest number of trunks in use figure, for the same hour period, for the consecutive twenty business day period by 20. This computation shall be performed for each end office and/or access tandem the customer wishes to serve.

Where the Special Access Service is exempt from the Special Access Surcharge as set forth in 7.4.2 following, the customer shall furnish with the order the certification as set forth in that section.

CANCELLED

MAY 1 1993  
BY lat R.S. #115  
Public Service Commission  
MISSOURI

FILED

NOV 7 1992

MO. PUBLIC SERVICE COMMISSION

EFFECTIVE:

~~October 17, 1992~~

NOV 7 1992

ISSUED:  
September 17, 1992

BY: John L. Roe  
Vice President - Administration  
5454 West 110th Street  
Overland Park, Kansas 66211

UNITED TELEPHONE COMPANY  
OF MISSOURI

Second Revised Page 116  
Cancels First Revised Page 116

ACCESS SERVICE

5. Ordering Options for Switched and Special Access Service (Cont'd)

RECEIVED

5.2 Access Order (Cont'd)

calendar year which add up to the largest number of trunks in use. The customer shall then determine the average busy hour trunks by dividing the largest number of trunks in use figure, for the same hour period, for the consecutive twenty business day period by 20. This computation shall be performed for each end office and/or access tandem the customer wishes to serve.

MO. PUBLIC SERVICE COMMISSION

(M)  
(M)

Where the Special Access Service is exempt from the Special Access Surcharge as set forth in 7.4.2 following, the customer shall furnish with the order the certification as set forth in that section.

5.2.1 Access Order Service Date Intervals

Access Service is provided with one of the following Service Date Intervals:

- Standard Interval
- Negotiated Interval

To the extent the Access Service can be made available with reasonable effort, the Telephone Company will provide the Access Service in accordance with the customer's requested interval, subject to the following conditions:

(A) Standard Interval

A schedule of Standard Intervals applicable for Switched and Special Access Services is included in 5.6 following. The schedule specifies the services and quantities that can be provided within Standard Intervals.

Access Services provided with a standard interval will be installed during Telephone Company business day. If a customer requests that installation be done outside of normally scheduled working hours, and the Telephone Company agrees to this request, the customer will be subject to applicable Additional Labor Charges as set forth in 13.2.6 following.

(B) Negotiated Interval

The Telephone Company will negotiate a service date interval with the customer when:

- (1) There is no Standard Interval for the service,
- (2) The quantity of Access Services ordered exceeds the quantities specified in the standard intervals in 5.6, or
- (3) The customer requests a service date beyond the applicable Standard Interval service date.

FEB 11 1995

MISSOURI  
Public Service Commission  
EFFECTIVE:

ISSUED:  
January 11, 1995

BY: John L. Roe  
February 11, 1995  
Vice President - Carrier and Regulatory Services  
5454 West 110th Street  
Overland Park, Kansas 66211

Cancelled  
April 30, 2007  
Missouri Public  
Service Commission

ACCESS SERVICE

RECEIVED

5. Ordering Options for Switched and Special Access Service (Cont'd) MAR 31 1993

5.2 Access Order (Cont'd)

MO. PUBLIC SERVICE COMM.

Where the Special Access Service is exempt from the Special Access Surcharge as set forth in 7.4.2 following, the customer shall furnish with the order the certification as set forth in that section.

(M)  
(M)

5.2.1 Access Order Service Date Intervals

Access Service is provided with one of the following Service Date Intervals:

CANCELLED

- Standard Interval
- Negotiated Interval

FEB 11 1995

To the extent the Access Service can be made available with reasonable effort, the Telephone Company will provide Access Service in accordance with the customer's requested interval, subject to the following conditions:

BY 2nd R.S. # 116  
Public Service Commission  
MISSOURI

(A) Standard Interval

A schedule of Standard Intervals applicable for Switched and Special Access Services is included in 5.6 following. The schedule specifies the services and quantities that can be provided within Standard Intervals.

Access Services provided with a standard interval will be installed during Telephone Company business day. If a customer requests that installation be done outside of normally scheduled working hours, and the Telephone Company agrees to this request, the customer will be subject to applicable Additional Labor Charges as set forth in 13.2.6 following.

(B) Negotiated Interval

The Telephone Company will negotiate a service date interval with the customer when:

- (1) There is no Standard Interval for the service,
- (2) The quantity of Access Services ordered exceeds the quantities specified in the standard intervals in 5.6, or
- (3) The customer requests a service date beyond the applicable Standard Interval service date.

MAY 01 1993

MO. PUBLIC SERVICE COMM.

ISSUED:  
March 31, 1993

BY: John L. Roe  
Vice President - Administration  
5454 West 110th Street  
Overland Park, Kansas 66211

EFFECTIVE:  
May 1, 1993

ACCESS SERVICE

RECEIVED

SEP 17 1992

5. Ordering Options for Switched and Special Access Service (Cont'd)

MISSOURI  
Public Service Commission

5.2 Access Order (Cont'd)

5.2.1 Access Order Service Date Intervals

Access Service is provided with one of the following Service Date Intervals:

- Standard Interval
- Negotiated Interval

To the extent the Access Service can be made available with reasonable effort, the Telephone Company will provide the Access Service in accordance with the customer's requested interval, subject to the following conditions:

(A) Standard Interval

A schedule of Standard Intervals applicable for Switched and Special Access Services is included in 5.6 following. The schedule specifies the services and quantities that can be provided within Standard Intervals.

Access Services provided with a standard interval will be installed during Telephone Company business day. If a customer requests that installation be done outside of normally scheduled working hours, and the Telephone Company agrees to this request, the customer will be subject to applicable Additional Labor Charges as set forth in 5.6 following.

CANCELLED

(B) Negotiated Interval

The Telephone Company will negotiate a service date with the customer when:

MAY 1 1993  
BY John L. Roe #116  
Public Service Commission  
MISSOURI

- (1) There is no Standard Interval for the service,
- (2) The quantity of Access Services ordered exceeds the quantities specified in the standard intervals in 5.6, or
- (3) The customer requests a service date beyond the applicable Standard Interval service date.

FILED

NOV 7 1992

MO. PUBLIC SERVICE COMMISSION

ISSUED:  
September 17, 1992

BY: John L. Roe  
Vice President - Administration  
5454 West 110th Street  
Overland Park, Kansas 66211

EFFECTIVE:  
~~October 17, 1992~~  
NOV 7 1992

SPRINT MISSOURI, INC.  
d/b/a SPRINT

Second Revised Page 117  
Cancels First Revised Page 117  
**Missouri Public**

ACCESS SERVICE

5. Ordering Options for Switched and Special Access Service (Cont'd)

REC'D JUL 02 2002

5.2 Access Order (Cont'd)

Service Commission

5.2.1 Access Order Service Date Intervals (Cont'd)

(B) Negotiated Interval (Cont'd)

The Telephone Company will offer a service date based on the type and quantity of Access Services the customer has requested. The Negotiated Interval may not exceed by more than six months the Standard Interval Service date, or, when there is no Standard Interval, the Telephone Company offered service date.

(D)  
|  
(D)

All services for which rates are applied on an individual case basis are provided with a Negotiated Interval.

5.2.2 Access Order Modifications

The customer may request a modification of its Access Order at any time prior to notification by the Telephone Company that service is available for the customer's use. The Telephone Company will make every effort to accommodate a requested modification when it is able to do so with the normal work force assigned to complete such an order within normal business hours. If the modification cannot be made with the normal work force during normal business hours, the Telephone Company will notify the customer. If the customer still desires the Access Order modification, the Telephone Company will schedule a new service date. All charges for Access Order modifications will apply on a per access order basis.

**Missouri Public**

FILED AUG 12 2002

Service Commission

ISSUED:  
July 2, 2002

Richard D. Lawson  
State Executive, External Affairs  
319 Madison  
Jefferson City, MO 65101

EFFECTIVE:

**AUG 12 2002**



UNITED TELEPHONE COMPANY  
OF MISSOURI

First Revised Page 117  
Cancels Original Page 117

**RECEIVED**

ACCESS SERVICE

5. Ordering Options for Switched and Special Access Service (Cont'd) 2 1994

5.2 Access Order (Cont'd)

MISSOURI  
Public Service Commission

5.2.1 Access Order Service Date Intervals (Cont'd)

(B) Negotiated Interval (Cont'd)

The Telephone Company will offer a service date based on the type and quantity of Access Services the customer has requested. The Negotiated Interval may not exceed by more than six months the Standard Interval Service date, or, when there is no Standard Interval, the Telephone Company offered service date.

All part-time Television and Program Audio service are provided with a Negotiated Interval. Each service is subject to a service inquiry. A service inquiry is a request to the Telephone Company to determine if facilities exist to provide the service ordered and to determine the service date on which service can be provided to the customer.

All services for which rates are applied on an individual case basis are provided with a Negotiated Interval.

5.2.2 Access Order Modifications

The customer may request a modification of its Access Order at any time prior to notification by the Telephone Company that service is available for the customer's use. The Telephone Company will make every effort to accommodate a requested modification when it is able to do so with the normal work force assigned to complete such an order within normal business hours. If the modification cannot be made with the normal work force during normal business hours, the Telephone Company will notify the customer. If the customer still desires the Access Order modification, the Telephone Company will schedule a new service date. All charges for Access Order modifications will apply on a per access order basis.

(T)

**FILED**

JUL - 5 1994

MISSOURI  
Public Service Commission  
EFFECTIVE DATE:  
July 5, 1994

ISSUED:  
June 2, 1994

John L. Roe  
Vice President - Administration  
5454 West 110th Street  
Overland Park, Kansas 66211

**CANCELLED**  
AUG 12 2002  
2nd RS 117  
Public Service Commission  
MISSOURI

UNITED TELEPHONE COMPANY  
OF MISSOURI

Original Page 117

RECEIVED

SEP 17 1992

ACCESS SERVICE

5. Ordering Options for Switched and Special Access Service (Cont'd)

5.2 Access Order (Cont'd)

MISSOURI  
PUBLIC SERVICE COMMISSION

5.2.1 Access Order Service Date Intervals (Cont'd)

(B) Negotiated Interval (Cont'd)

The Telephone Company will offer a service date based on the type and quantity of Access Services the customer has requested. The Negotiated Interval may not exceed by more than six months the Standard Interval Service date, or, when there is no Standard Interval, the Telephone Company offered service date.

All part-time Television and Program Audio service are provided with a Negotiated Interval. Each service is subject to a service inquiry. A service inquiry is a request to the Telephone Company to determine if facilities exist to provide the service ordered and to determine the service date on which service can be provided to the customer.

All services for which rates are applied on an individual case basis are provided with a Negotiated Interval.

5.2.2 Access Order Modifications

The customer may request a modification of its Access Order at any time prior to notification by the Telephone Company that service is available for the customer's use. The Telephone Company will make every effort to accommodate a requested modification when it is able to do so with the normal work force assigned to complete such an order within normal business hours. If the modification cannot be made with the normal work force during normal business hours, the Telephone Company will notify the customer. If the customer still desires the Access Order modification, the Telephone Company will schedule a new service date. All charges for Access Order modifications will apply on a per occurrence basis.

CANCELLED

JUL 5 1994  
BY *Int R.S. # 117*  
Public Service Commission  
MISSOURI

FILED

NOV 7 1992

MO. PUBLIC SERVICE COMMISSION

EFFECTIVE:

~~October 1, 1992~~

NOV 7 1992

ISSUED:  
September 17, 1992

BY: John L. Roe  
Vice President - Administration  
5454 West 110th Street  
Overland Park, Kansas 66211

ACCESS SERVICE

5. Ordering Options for Switched and Special Access Service (Cont'd)

5.2 Access Order (Cont'd)

5.2.2 Access Order Modifications (Cont'd)

When Telephone Company personnel are dispatched to install a customer's service on the requested service date, and the customer advises the Telephone Company personnel that service cannot be accepted at that time, the customer shall be responsible for payment of additional labor charges for the time incurred by Telephone Company personnel. The additional labor charges will be applied on per half hour, per technician basis as set forth in 13.2 following.

Any increase in the number of Special Access Service channels or Switched Access Service lines or trunks will be treated as a new Access Order (for the increased amount only).

If order modifications are necessary to satisfy the transmission performance for a Special Access Service ordered by a customer, these changes will be made without order modification charges being incurred by the customer.

(A) Service Date Change Charge

Access Order service dates for the installation of new services or rearrangements of existing services may be changed, but the new service date may not exceed the original service date by more than 120 calendar days. When, for any reason, the customer indicates that service cannot be accepted for a period not to exceed 120 calendar days, and the Telephone Company accordingly delays the start of service, a Service Date Change Charge will apply. If the customer requested service date is more than 120 calendar days after the original service date, the order will be canceled by the Telephone Company and reissued with the appropriate cancellation charges applied unless the customer indicates that billing for the service is to commence as set forth in 5.2.3(A) following.

ISSUED:  
March 30, 2007

Mark D. Harper  
Director - State Regulatory  
5454 W. 110th Street  
Overland Park, Kansas 66211

EFFECTIVE:  
April 30, 2007

CANCELLED  
April 18, 2017  
Missouri Public  
Service Commission  
JI-2017-0177

**Filed**  
Missouri Public  
Service Commission



SPRINT MISSOURI, INC.  
d/b/a SPRINT

Third Revised Page 118  
Cancels Second Revised Page 118

Missouri Public

ACCESS SERVICE

REC'D JAN 07 2002

5. Ordering Options for Switched and Special Access Service (Cont'd)

Service Commission

5.2 Access Order (Cont'd)

5.2.2 Access Order Modifications (Cont'd)

When Telephone Company personnel are dispatched to install a customer's service on the requested service date, and the customer advises the Telephone Company personnel that service cannot be accepted at that time, the customer shall be responsible for payment of additional labor charges for the time incurred by Telephone Company personnel. The additional labor charges will be applied on per half hour, per technician basis as set forth in 13.2 following.

Any increase in the number of Special Access Service channels or Switched Access Service lines **or trunks will** be treated as a new Access Order (for the increased amount only). (C)

If order modifications are necessary to satisfy the transmission performance for a Special Access Service ordered by a customer, these changes will be made without order modification charges being incurred by the customer.

(A) Service Date Change Charge

Access Order service dates for the installation of new services or rearrangements of existing services may be changed, but the new service date may not exceed the original service date by more than 120 calendar days. When, for any reason, the customer indicates that service cannot be accepted for a period not to exceed 120 calendar days, and the Telephone Company accordingly delays the start of service, a Service Date Change Charge will apply. If the customer requested service date is more than 120 calendar days after the original service date, the order will be canceled by the Telephone Company and reissued with the appropriate cancellation charges applied unless the customer indicates that billing for the service is to commence as set forth in 5.2.3(A) following.

Missouri Public

FILED FEB 07 2002

Service Commission

ISSUED:  
January 7, 2002

Richard D. Lawson  
State Executive, External Affairs  
319 Madison  
Jefferson City, MO 65101

EFFECTIVE:  
February 7, 2002

Cancelled

April 30, 2007  
Missouri Public  
Service Commission

SPRINT MISSOURI, INC.  
d/b/a SPRINT

Second Revised Page 118  
Cancels First Revised Page 118

**Missouri Public  
Service Commission**

ACCESS SERVICE

REC'D MAY 03 2000

5. Ordering Options for Switched and Special Access Service (Cont'd)

5.2 Access Order (Cont'd)

5.2.2 Access Order Modifications (Cont'd)

When Telephone Company personnel are dispatched to install a customer's service on the requested service date, and the customer advises the Telephone Company personnel that service cannot be accepted at that time, the customer shall be responsible for payment of additional labor charges for the time incurred by Telephone Company personnel. The additional labor charges will be applied on per half hour, per technician basis as set forth in 13.2 following.

(N)  
|  
(N)

Any increase in the number of Special Access Service channels or Switched Access Service lines, trunks, busy hour minutes of capacity will be treated as a new Access Order (for the increased amount only).

If order modifications are necessary to satisfy the transmission performance for a Special Access Service ordered by a customer, these changes will be made without order modification charges being incurred by the customer.

(A) Service Date Change Charge

Access Order service dates for the installation of new services or rearrangements of existing services may be changed, but the new service date may not exceed the original service date by more than 120 calendar days. When, for any reason, the customer indicates that service cannot be accepted for a period not to exceed 120 calendar days, and the Telephone Company accordingly delays the start of service, a Service Date Change Charge will apply. If the customer requested service date is more than 120 calendar days after the original service date, the order will be canceled by the Telephone Company and reissued with the appropriate cancellation charges applied unless the customer indicates that billing for the service is to commence as set forth in 5.2.3(A) following.

(M)  
|  
(M)

**Missouri Public  
Service Commission** (M)

FILED JUN 02 2000

(M) Material moved to Page 119.

CANCELLED

FEB 07 2002

34 R P 118  
Public Service Commission  
MISSOURI

ISSUED:  
May 3, 2000

Richard D. Lawson  
State Executive, External Affairs

EFFECTIVE:  
June 2, 2000

ACCESS SERVICE

**RECEIVED**

5. Ordering Options for Switched and Special Access Service (Cont'd) JUN 2 1994

5.2 Access Order (Cont'd)

MISSOURI  
Public Service Commission

5.2.2 Access Order Modifications (Cont'd)

Any increase in the number of Special Access Service channels or Switched Access Service lines, trunks, busy hour minutes of capacity will be treated as a new Access Order (for the increased amount only).

If order modifications are necessary to satisfy the transmission performance for a Special Access Service ordered by a customer, these changes will be made without order modification charges being incurred by the customer.

(A) Service Date Change Charge

Access Order service dates for the installation of new services or rearrangements of existing services may be changed, but the new service date may not exceed the original service date by more than 120 calendar days. (T)  
When, for any reason, the customer indicates that service cannot be accepted for a period not to exceed 120 calendar days, and the Telephone Company accordingly delays the start of service, a Service Date Change Charge will apply. If the customer requested service date is more than 120 calendar days after the original service date, the order will be canceled by the Telephone Company and reissued with the appropriate cancellation charges applied unless the customer indicates that billing for the service is to commence as set forth in 5.2.3(A) following. (T)

A new service date may be established that is prior to the original standard or negotiated interval service date if the Telephone Company determines it can accommodate the customer's request without delaying service dates for orders of other customers. If the service date is changed to an earlier date, the customer will be notified by the Telephone Company that Expedited Order Charges as set forth in (D) following will apply. Such charges will apply in addition to the Service Date Change Charge. (T)

**CANCELLED**

JUN 02 2000  
L 2nd RP 118  
Public Service Commission  
MISSOURI

**FILED**

JUL - 5 1994

MISSOURI  
Public Service Commission  
EFFECTIVE DATE  
July 5, 1994

ISSUED:  
June 2, 1994

John L. Roe  
Vice President - Administration  
5454 West 110th Street  
Overland Park, Kansas 66211

RECEIVED

SEP 17 1992

MISSOURI  
Public Service Commission

ACCESS SERVICE

5. Ordering Options for Switched and Special Access Service (Cont'd)

5.2 Access Order (Cont'd)

5.2.2 Access Order Modifications (Cont'd)

Any increase in the number of Special Access Service channels or Switched Access Service lines, trunks, busy hour minutes of capacity will be treated as a new Access Order (for the increased amount only).

If order modifications are necessary to satisfy the transmission performance for a Special Access Service ordered by a customer, these changes will be made without order modification charges being incurred by the customer.

(A) Service Date Change Charge

Access Order service dates for the installation of new services or rearrangements of existing services may be changed, but the new service date may not exceed the original service date by more than 30 calendar days. When, for any reason, the customer indicates that service cannot be accepted for a period not to exceed 30 calendar days, and the Telephone Company accordingly delays the start of service, a Service Date Change Charge will apply. If the customer requested service date is more than 30 calendar days after the original service date, the order will be canceled by the Telephone Company and reissued with the appropriate cancellation charges applied unless the customer indicates that billing for the service is to commence as set forth in 5.2.3(A) following.

A new service date may be established that is prior to the original standard or negotiated interval service date if the Telephone Company determines it can accommodate the customer's request without delaying service dates for orders of other customers. If the service date is changed to an earlier date, the customer will be notified by the Telephone Company that Expedited Order Charges as set forth in (D) following will apply. Such charges will apply in addition to the Service Date Change Charge.

CANCELLED

JUL 5 1994  
BY *Let P.S. # 118*  
Public Service Commission  
MISSOURI

FILED

NOV 7 1992

MO. PUBLIC SERVICE COMM.  
EFFECTIVE:

~~October 17, 1992~~  
NOV 7 1992

ISSUED:  
September 17, 1992

BY: John L. Roe  
Vice President - Administration  
5454 West 110th Street  
Overland Park, Kansas 66211

ACCESS SERVICE

5. Ordering Options for Switched and Special Access Service (Cont'd)

5.2 Access Order (Cont'd)

5.2.2 Access Order Modifications (Cont'd)

(A) Service Date Change Charge (Cont'd)

A new service date may be established that is prior to the original standard or negotiated interval service date if the Telephone Company determines it can accommodate the customer's request without delaying service dates for orders of other customers. If the service date is changed to an earlier date, the customer will be notified by the Telephone Company that Expedited Order Charges as set forth in (D) following will apply. Such charges will apply in addition to the Service Date Change Charge.

A Service Date Change Charge will apply, on a per order occurrence basis, for each service date changed. The applicable charge is:

	<u>Charge</u>
Service Date Change Charge per order	\$11.00

(B) Partial Cancellation Charge

Any decrease in the number of ordered Special Access Service channels or Switched Access Service lines or trunks will be treated as a partial cancellation and the charges as set forth in 5.2.3(C) following will apply.

ISSUED:  
March 30, 2007

Mark D. Harper  
Director - State Regulatory  
5454 W. 110th Street  
Overland Park, Kansas 66211

EFFECTIVE:  
April 30, 2007

SPRINT MISSOURI, INC.  
d/b/a SPRINT

Second Revised Page 119  
Cancels First Revised Page 119

ACCESS SERVICE

Missouri Public

5. Ordering Options for Switched and Special Access Service (Cont'd)

REC'D JAN 07 2002

5.2 Access Order (Cont'd)

Service Commission

5.2.2 Access Order Modifications (Cont'd)

(A) Service Date Change Charge (Cont'd)

A new service date may be established that is prior to the original standard or negotiated interval service date if the Telephone Company determines it can accommodate the customer's request without delaying service dates for orders of other customers. If the service date is changed to an earlier date, the customer will be notified by the Telephone Company that Expedited Order Charges as set forth in (D) following will apply. Such charges will apply in addition to the Service Date Change Charge.

A Service Date Change Charge will apply, on a per order occurrence basis, for each service date changed. The applicable charge is:

	<u>Charge</u>
Service Date Change Charge per order	\$11.00

(B) Partial Cancellation Charge

Any decrease in the number of ordered Special Access Service channels or Switched Access Service lines **or trunks will** be treated as a partial cancellation and the charges as set forth in 5.2.3(C) following will apply.

(C)

Missouri Public

FILED FEB 07 2002

Service Commission

ISSUED:  
January 7, 2002

Richard D. Lawson  
State Executive, External Affairs  
319 Madison  
Jefferson City, MO 65101

EFFECTIVE:  
February 7, 2002





UNITED TELEPHONE COMPANY  
OF MISSOURI

Original Page 119

RECEIVED

SEP 17 1992

ACCESS SERVICE

5. Ordering Options for Switched and Special Access Service (Cont'd) MISSOURI  
Public Service Commission

5.2 Access Order (Cont'd)

5.2.2 Access Order Modifications (Cont'd)

(A) Service Date Change Charge (Cont'd)

A Service Date Change Charge will apply, on a per order occurrence basis, for each service date changed. The applicable charge is:

	<u>USOC</u>	<u>Charge</u>
Service Date Change Charge per order	OMC	\$11.00

(B) Partial Cancellation Charge

Any decrease in the number of ordered Special Access Service channels or Switched Access Service lines, trunks, busy hour minutes of capacity, will be treated as a partial cancellation and the charges as set forth in 5.2.3(C) following will apply.

CANCELLED

JUN 02 2000

By *JSRP 119*  
Public Service Commission  
MISSOURI

FILED

NOV 7 1992

ISSUED:  
September 17, 1992

BY: John L. Roe  
Vice President - Administration  
5454 West 110th Street  
Overland Park, Kansas 66211

MO. PUBLIC SERVICE COMMISSION  
EFFECTIVE:  
~~October 27, 1992~~  
NOV 7 1992

ACCESS SERVICE

RECEIVED

5. Ordering Options for Switched and Special Access Service (Cont'd) SEP 17 1992

5.2 Access Order (Cont'd)

5.2.2 Access Order Modifications (Cont'd)

(C) Design Change Charge

The customer may request a design change to the service ordered. A design change is any change to an Access Order which requires engineering review. An engineering review is a review by Telephone Company personnel of the service ordered and the requested changes to determine what changes in the design, if any, are necessary to meet the changes requested by the customer. Design changes include such things as the addition or deletion of optional features or functions or a change in the type of Transport Termination (Switched Access only), type of channel interface, type of Interface Group or technical specification package. Design changes do not include a change of customer premises, end user premises, end office switch, Feature Group type or Special Access Service channel type. Changes of this nature will require the issuance of a new order and the cancellation of the original order with appropriate cancellation charges applied.

The Telephone Company will review the requested change, notify the customer whether the change is a design change, if it can be accommodated and if a new service date is required. If the customer authorizes the Telephone Company to proceed with the design change, a Design Change Charge will apply. The Design Change Charge will apply on a per order occurrence basis, for each order requiring a design change. The applicable charge is:

FILED

NOV 7 1992

MO. PUBLIC SERVICE COMMISSION  
EFFECTIVE:

~~October 1, 1992~~

NOV 7 1992

ISSUED:  
September 17, 1992

BY: John L. Roe  
Vice President - Administration  
5454 West 110th Street  
Overland Park, Kansas 66211

Cancelled

ACCESS SERVICE

5. Ordering Options for Switched and Special Access Service (Cont'd)

5.2 Access Order (Cont'd)

5.2.2 Access Order Modifications (Cont'd)

(C) Design Change Charge (Cont'd)

	<u>Charge</u>
Design Change Charge, Per Order	\$11.00

- (D) If, as a result of the charge, the original service date cannot be met without the Telephone Company incurring additional labor, and the customer provides authorization to the Telephone Company to proceed, then the charges as set forth in Section 13 will apply. If the customer is unwilling to pay such costs, the service date must be changed in accordance with (A) preceding as a result of the design change.

Expedited Order Charge

When placing an Access Order for service(s) for which standard intervals exist, a customer may request a service date that is prior to the standard interval service date. A customer may also request an earlier service date on a pending standard or negotiated interval Access Order. If the Telephone Company agrees to provide service on an expedited basis, an Expedited Order Charge will apply.

If the Telephone Company is subsequently unable to meet an agreed upon expedited service date, no Expedited Order Charge will apply unless the missed service date was caused by the customer.

ISSUED:  
March 30, 2007

Mark D. Harper  
Director - State Regulatory  
5454 W. 110th Street  
Overland Park, Kansas 66211

EFFECTIVE:  
April 30, 2007

SPRINT MISSOURI, INC.  
d/b/a SPRINT

Second Revised Page 121  
Cancels First Revised Page 121

ACCESS SERVICE

Missouri Public

5. Ordering Options for Switched and Special Access Service (Cont'd)

REC'D JAN 07 2002

5.2 Access Order (Cont'd)

Service Commission

5.2.2 Access Order Modifications (Cont'd)

(C) Design Change Charge (Cont'd)

	<u>Charge</u>
Design Change Charge, Per Order	\$11.00

(D) *If, as a result of the charge, the original service date cannot be met without the Telephone Company incurring additional labor, and the customer provides authorization to the Telephone Company to proceed, then the charges as set forth in Section 13 will apply. If the customer is unwilling to pay such costs, the service date must be changed in accordance with (A) preceding as a result of the design change.*

(C)  
|  
(C)

Expedited Order Charge

When placing an Access Order for service(s) for which standard intervals exist, a customer may request a service date that is prior to the standard interval service date. A customer may also request an earlier service date on a pending standard or negotiated interval Access Order. If the Telephone Company agrees to provide service on an expedited basis, an Expedited Order Charge will apply.

If the Telephone Company is subsequently unable to meet an agreed upon expedited service date, no Expedited Order Charge will apply unless the missed service date was caused by the customer.

Missouri Public

FILED FEB 07 2002

Service Commission

ISSUED:  
January 7, 2002

Richard D. Lawson  
State Executive, External Affairs  
319 Madison  
Jefferson City, MO 65101

EFFECTIVE:  
February 7, 2002

Cancelled

April 30, 2007  
Missouri Public  
Service Commission



SPRINT MISSOURI, INC.  
d/b/a SPRINT

First Revised Page 121  
Cancels Original Page 121

ACCESS SERVICE

5. Ordering Options for Switched and Special Access Service (Cont'd)

5.2 Access Order (Cont'd)

**Missouri Public  
Service Commission**

5.2.2 Access Order Modifications (Cont'd)

REC'D MAY 03 2000

(C) Design Change Charge (Cont'd)

	<u>Charge</u>	(C)
Design Change Charge, Per Order	\$11.00	(C)

(D) If a change of service date is required, the Service Date Change Charge as set forth in (A) preceding will also apply.

Expedited Order Charge

When placing an Access Order for service(s) for which standard intervals exist, a customer may request a service date that is prior to the standard interval service date. A customer may also request an earlier service date on a pending standard or negotiated interval Access Order. If the Telephone Company agrees to provide service on an expedited basis, an Expedited Order Charge will apply.

If the Telephone Company is subsequently unable to meet an agreed upon expedited service date, no Expedited Order Charge will apply unless the missed service date was caused by the customer.

**CANCELLED**

FEB 07 2002  
By *2nd RP121*  
**Public Service Commission  
MISSOURI**

**Missouri Public  
Service Commission**

FILED JUN 02 2000

ISSUED:  
May 3, 2000

Richard D. Lawson  
State Executive, External Affairs

EFFECTIVE:  
June 2, 2000

UNITED TELEPHONE COMPANY  
OF MISSOURI

Original Page 121

RECEIVED

SEP 17 1992

MISSOURI  
Public Service Commission

ACCESS SERVICE

5. Ordering Options for Switched and Special Access Service (Cont'd)

5.2 Access Order (Cont'd)

5.2.2 Access Order Modifications (Cont'd)

(C) Design Change Charge (Cont'd)

	<u>USOC</u>	<u>Charge</u>
Design Change Charge, Per Order	H28	\$11.00

(D) If a change of service date is required, the Service Date Change Charge as set forth in (A) preceding will also apply.

Expedited Order Charge

When placing an Access Order for service(s) for which standard intervals exist, a customer may request a service date that is prior to the standard interval service date. A customer may also request an earlier service date on a pending standard or negotiated interval Access Order. If the Telephone Company agrees to provide service on an expedited basis, an Expedited Order Charge will apply.

If the Telephone Company is subsequently unable to meet an agreed upon expedited service date, no Expedited Order Charge will apply unless the missed service date was caused by the customer.

CANCELLED

JUN 02 2000  
By 1st RP 121  
Public Service Commission  
MISSOURI

FILED

NOV 7 1992

MO. PUBLIC SERVICE COMMISSION  
EFFECTIVE:

~~October 28, 1992~~

NOV 7 1992

ISSUED:  
September 17, 1992

BY: John L. Roe  
Vice President - Administration  
5454 West 110th Street  
Overland Park, Kansas 66211

UNITED TELEPHONE COMPANY  
OF MISSOURI

Original Page 122

RECEIVED

SEP 17 1992

ACCESS SERVICE

5. Ordering Options for Switched and Special Access Service (Cont'd) MIRI  
File 100-20000-100

5.2 Access Order (Cont'd)

5.2.2 Access Order Modification (Cont'd)

Expedited Order Charge (Cont'd)

If the Telephone Company receives a request for an expedited service date at the time a Standard Interval Access Order is placed, the Expedited Order Charge is calculated by summing all the nonrecurring charges associated with the order and then dividing this total by the number of days in the Standard Interval, as specified in 5.6 following. The charge is then applied on a per day of improvement basis, per order, but in no event shall the charge exceed fifty percent of the total nonrecurring charges associated with the Access Order.

When the Telephone Company receives a request for expediting a pending standard or negotiated interval Access Order, the Expedited Order Charge is based on the extent to which the Access Order has been processed at the time to the Telephone Company agrees to the service date improvement and is calculated as follows:

- Based on the critical dates associated with the Access Order, as defined in 5.2.3(C)(4)(b) following, the Telephone Company will determine which critical date will be next completed on the order.
- Using the table of 5.2.3(C)(4)(d) following and the critical date as determined above, the Telephone Company will determine the percent of the provisioning interval not yet completed.
- The Telephone Company will apply this percentage to the sum of all the nonrecurring charges associated with the order and divide this sum by the number of days remaining in the original service interval.
- The per day charges so developed will then be applied on a per day of improvement basis, per order, but in no event shall the charge exceed fifty percent of the total nonrecurring charges associated with the Access Order.

FILED

NOV 11 1992

MO. PUBLIC SERVICE COMMISSION

EFFECTIVE:

~~September 17, 1992~~

NOV 7 1992

ISSUED:  
September 17, 1992

BY: John L. Roe  
Vice President - Administration  
5454 West 110th Street  
Overland Park, Kansas 66211

Cancelled  
April 30, 2007  
Missouri Public  
Service Commission

UNITED TELEPHONE COMPANY  
OF MISSOURI

Original Page 123

RECEIVED

SEP 17 1992

ACCESS SERVICE

- 5. Ordering Options for Switched and Special Access Service (Cont'd)
- 5.2 Access Order (Cont'd)

5.2.2 Access Order Modifications (Cont'd)

Expedited Order Charge (Cont'd)

The Expedited Order Charge presumes that all requests for expediting result only in overtime labor costs being incurred by the Telephone Company. If costs other than such overtime labor are to be incurred when an Access Order is expedited, the Telephone Company will develop and quote such costs to the customer, obtain customer authorization and bill the customer in accordance with the special construction terms and conditions of Section 14 following.

When the request for expediting occurs subsequent to the Application Date of the Access Order, a Service Date Change Charge as set forth in (A) preceding also applies.

FILED

NOV 5 1992

MO PUBLIC SERVICE COMMISSION

EFFECTIVE:

~~October 1, 1992~~  
NOV 7 1992

ISSUED:  
September 17, 1992

BY: John L. Roe  
Vice President - Administration  
5454 West 110th Street  
Overland Park, Kansas 66211

Cancelled  
April 30, 2007  
Missouri Public  
Service Commission

ACCESS SERVICE

5. Ordering Options for Switched and Special Access Service (Cont'd)

5.2 Access Order (Cont'd)

5.2.3 Cancellation of an Access Order

- (A) A customer may cancel an Access Order for the installation of service at any time prior to notification by the Telephone Company that service is available for the customer's use. The cancellation date is the date the Telephone Company receives written or verbal notice from the customer that the order is to be canceled. If a customer or a customer's end user is unable to accept Access Service within 30 calendar days of the latest agreed upon service date, the customer has the choice of the following options:

The Access Order shall be canceled and charges set forth in (C) following will apply, or

Billing for the service will commence.

In any event, the cancellation date or the date billing is to commence (depending on which option is selected by the customer) shall be the 31st day beyond the latest agreed upon service date of the Access Order.

- (B) Reserved For Future Use
- (C) When a customer cancels an Access Order for the installation of service, a Cancellation Charge will apply as follows:
- (1) Costs incurred in conjunction with the provision of Switched or Special Access Service starts on the Application Date as defined in (4)(b) following.
  - (2) When the customer cancels an Access Order prior to the Scheduled Issue Date, as defined in (4)(b) following, no charges shall apply.

ISSUED:  
March 30, 2007

Mark D. Harper  
Director - State Regulatory  
5454 W. 110th Street  
Overland Park, Kansas 66211

EFFECTIVE:  
April 30, 2007



SPRINT MISSOURI, INC.  
d/b/a SPRINT

First Revised Page 124  
Cancels Original Page 124.  
Missouri Public Service Commission

ACCESS SERVICE

REC'D DEC 17 1999

5. Ordering Options for Switched and Special Access Service (Cont'd)

5.2 Access Order (Cont'd)

5.2.3 Cancellation of an Access Order

(A) A customer may cancel an Access Order for the installation of service at any time prior to notification by the Telephone Company that service is available for the customer's use. The cancellation date is the date the Telephone Company receives written or verbal notice from the customer that the order is to be canceled. If a customer or a customer's end user is unable to accept Access Service within 30 calendar days of the latest agreed upon service date, the customer has the choice of the following options: (C)

The Access Order shall be canceled and charges set forth in (C) following will apply, or

Billing for the service will commence.

In any event, the cancellation date or the date billing is to commence (depending on which option is selected by the customer) shall be the 31st day beyond the latest agreed upon service date of the Access Order. (C)

(B) Reserved For Future Use

(C) When a customer cancels an Access Order for the installation of service, a Cancellation Charge will apply as follows:

- (1) Costs incurred in conjunction with the provision of Switched or Special Access Service starts on the Application Date as defined in (4)(b) following.
- (2) When the customer cancels an Access Order prior to the Scheduled Issue Date, as defined in (4)(b) following, no charges shall apply.

MISSOURI PUBLIC SERVICE COMMISSION

FEB JAN 17 2000

ISSUED:  
December 17, 1999

Richard D. Lawson  
State Executive, External Affairs

EFFECTIVE:  
January 17, 2000

RECEIVED

SEP 17 1992

MISSOURI  
Public Service Commission

ACCESS SERVICE

5. Ordering Options for Switched and Special Access Service (Cont'd)

5.2 Access Order (Cont'd)

5.2.3 Cancellation of an Access Order

(A) A customer may cancel an Access Order for the installation of service at any time prior to notification by the Telephone Company that service is available for the customer's use. The cancellation date is the date the Telephone Company receives written or verbal notice from the customer that the order is to be canceled. The verbal notice must be followed by written confirmation within 10 days. If a customer or a customer's end user is unable to accept Access Service within 30 calendar days of the original service date, the customer has the choice of the following options:

The Access Order shall be canceled and charges set forth in (C) following will apply, or

Billing for the service will commence.

In any event, the cancellation date or the date billing is to commence (depending on which option is selected by the customer) shall be the 31st day beyond the original service date of the Access Order.

(B) Reserved For Future Use

(C) When a customer cancels an Access Order for the installation of service, a Cancellation Charge will apply as follows:

- (1) Costs incurred in conjunction with the provision of Switched or Special Access Service starts on the Application Date as defined in (4)(b) following.
- (2) When the customer cancels an Access Order prior to the Scheduled Issue Date, as defined in (4)(b) following, no charges shall apply.

CANCELLED

JAN 17 2000

By *15 RP124*  
Public Service Commission  
MISSOURI

FILED

NOV 7 1992

MO. PUBLIC SERVICE COMMISSION

EFFECTIVE:

~~OCTOBER 17, 1992~~

NOV 7 1992

ISSUED:  
September 17, 1992

BY: John L. Roe  
Vice President - Administration  
5454 West 110th Street  
Overland Park, Kansas 66211

UNITED TELEPHONE COMPANY  
OF MISSOURI

Original Page 125

RECEIVED

SEP 17 1992

ACCESS SERVICE

5. Ordering Options for Switched and Special Access Service (Cont'd)

5.2 Access Order (Cont'd)

5.2.3 Cancellation of an Access Order (Cont'd)

(C) (Cont'd)

- (3) When the customer cancels an Access Order on or after the Scheduled Issue Date, a charge equal to the estimated costs incurred by the Telephone Company shall apply. Such charge is determined as specified in (4) following.
- (4) Charges applicable as specified in (3) preceding are based on the estimated costs incurred by the Telephone Company at the time the order is canceled. The estimated costs incurred are determined based on the following:
  - (a) Certain Telephone Company critical dates are associated with an Access Order provisioning interval, whether standard or negotiated. These dates are used by the Telephone Company to monitor the progress of the provisioning process. At any point in the Access Order interval the Telephone Company is able to determine which critical date was last completed and can thus determine what percentage of the Telephone Company's provisioning costs have been incurred as of that critical date.
  - (b) The critical dates tracked by the Telephone Company are as follows:
    - Application Date (APP): The date the customer provides a firm commitment and sufficient information as detailed in 5.1 preceding to the Telephone Company. This is also the order date.

FILED

NOV 5 1992

MO. PUBLIC SERVICE COMMISSION

EFFECTIVE:

~~October 17, 1992~~

NOV 7 1992

ISSUED:  
September 17, 1992

BY: John L. Roe  
Vice President - Administration  
5454 West 110th Street  
Overland Park, Kansas 66211

Cancelled  
April 30, 2007  
Missouri Public  
Service Commission



RECEIVED

SEP 17 1992

MISSOURI  
Commission

ACCESS SERVICE

5. Ordering Options for Switched and Special Access Service (Cont'd)

5.2 Access Order (Cont'd)

5.2.3 Cancellation of an Access Order (Cont'd)

(C) (Cont'd)

(4) (Cont'd)

(b) (Cont'd)

- Scheduled Issue Date (SID): The date that the order is to be entered in the Telephone Company's order distribution system.
- Design Layout Report Date (DLRD): The date the Design Layout Report (DLR) is to be forwarded to the customer.
- Confirming the Design Layout Report Date (CDLRD): The date the Design Layout Report (DLR) is to be confirmed by the customer.
- Records Issue Date (RID): The date that all design and assignment information is to be sent to the central office and installation forces.
- Wired and Office Tested Date (WOT): The date by which all intraoffice wiring is to be completed, all plug-ins optioned, aligned, and frame continuity established, and the interoffice facilities, if applicable, tested. In addition, switching equipment, including translation loading, is to be installed and tested.
- Plant Test Date (PTD): The date on which overall testing of the service is to be started.
- Service Date (DD): The date on which service is to be made available to the customer. This is sometimes referred to as the Due Date.

FILED

NOV 7 1992

MO. PUBLIC SERVICE COMMISSION

EFFECTIVE:

~~October 17, 1992~~

NOV 7 1992

ISSUED:  
September 17, 1992

BY: John L. Roe  
Vice President - Administration  
5454 West 110th Street  
Overland Park, Kansas 66211

ACCESS SERVICE

RECEIVED

SEP 17 1992

5. Ordering Options for Switched and Special Access Service (Cont'd)

5.2 Access Order (Cont'd)

5.2.3 Cancellation of an Access Order (Cont'd)

(C) (Cont'd)

(4) (Cont'd)

(c) The percentage of the total provisioning cost incurred by the Telephone Company at a particular critical date varies by the type of service as shown in (d) following.

(d) When a customer cancels an Access Order, or part of an Access Order, before the service date, the Telephone Company will apply cancellation charges to the order by multiplying all the nonrecurring charges associated with the order, or that part of the order being canceled, by the percentage shown following for the critical date last completed on the order:

	<u>APP</u>	<u>SID</u>	<u>DLRD</u>	<u>RID</u>	<u>WOT</u>	<u>PTD</u>	<u>DD</u>
FGA	0%	45%	65%	90%	98%	100%	MINIMUM PERIOD CHARGES APPLY
FGB	0%	15%	25%	80%	98%	100%	"
FGC	0%	15%	25%	80%	98%	100%	"
FGD	0%	15%	25%	80%	98%	100%	"
WAL	0%	45%	65%	90%	98%	100%	"
MT	0%	45%	65%	90%	98%	100%	"
TG	0%	45%	65%	90%	98%	100%	"
VG	0%	45%	65%	90%	98%	100%	"
AP	0%	45%	65%	90%	98%	100%	"
TV	0%	45%	65%	90%	98%	100%	"

FILED

NOV 7 1992

ISSUED:  
September 17, 1992

BY: John L. Roe  
Vice President - Administration  
5454 West 110th Street  
Overland Park, Kansas 66211

MO. PUBLIC SERVICE COMM.  
EFFECTIVE:

~~October 17, 1992~~

NOV 7 1992

ACCESS SERVICE

RECEIVED

5. Ordering Options for Switched and Special Access Service (Cont'd) SEP 17 1992

5.2 Access Order (Cont'd)

5.2.3 Cancellation of an Access Order (Cont'd)

(C) (Cont'd)

(4) (Cont'd)

(d) (Cont'd)

	<u>APP</u>	<u>SID</u>	<u>DLRD</u>	<u>RID</u>	<u>WOT</u>	<u>PTD</u>	<u>DD</u>
WA	0%	45%	65%	90%	98%	100%	Minimum Period Charges Apply
WD	0%	45%	65%	90%	98%	100%	
DA	0%	45%	65%	90%	98%	100%	
HC	0%	45%	65%	90%	98%	100%	

(D) When a customer cancels an order for the discontinuance of service, no charges apply for the cancellation.

(E) If the Telephone Company misses a service date by more than 30 days due to circumstances over which it has direct control (excluding, e.g., acts of God, governmental requirements, work stoppages and civil commotions), the customer may cancel the Access Order without incurring cancellation charges.

FILED

NOV 7 1992

MO. PUBLIC SERVICE COMMISSION

EFFECTIVE:

~~October 27, 1992~~

NOV 7 1992

ISSUED:  
September 17, 1992

BY: John L. Roe  
Vice President - Administration  
5454 West 110th Street  
Overland Park, Kansas 66211

Cancelled



SPRINT MISSOURI, INC.  
d/b/a SPRINT

Second Revised Page 129  
Cancels First Revised Page 129  
**Missouri Public**

ACCESS SERVICE

REC'D JUL 02 2002

5. Ordering Options for Switched and Special Access Service (Cont'd)

Service Commission

5.2 Access Order (Cont'd)

5.2.4 Selection Of Facilities For Access Orders

- (A) When a customer places an Access Order, it may choose to utilize facilities previously purchased as a facility to a Hub. If the customer has a high capacity interface for use with Switched Access Service Interface Groups 6 and 9, or has a Special Access Service facility purchased to a Hub, the customer must request that specific channels be used to implement the Access Order. If a facility assignment is not specified by the customer, the Telephone Company will provide the service from available inventory as discussed in 5.3 following.
- (B) For all other Access Orders, the option to request a transmission path or channel is not provided except as provided for under Special Facilities Routing as set forth in 11. following.

5.2.5 Minimum Period

- (A) Except as set forth in (B), (C), 7.4.4, 8.1.5(B), 8.3.5(A), 9.4(A) and 13.3.5(C)(1)(b), (c) and (d) following, the minimum period for which Access Service is provided and for which charges are applicable, is one month.
- (B) The minimum period for Switched Access Service Feature Group D is three months.
- (C) Reserved for Future Use

(D)  
|  
(D)

ISSUED:  
July 2, 2002

Richard D. Lawson  
State Executive, External Affairs  
319 Madison  
Jefferson City, MO 65101

**Missouri Public**

FILED AUG 12 2002

Service Effective: ~~August 12, 2002~~

AUG 12 2002

SPRINT MISSOURI, INC.  
d/b/a SPRINT

First Revised Page 129  
Cancels Original Page 129

ACCESS SERVICE

5. Ordering Options for Switched and Special Access Service (Cont'd)

**Missouri Public  
Service Commission**

5.2 Access Order (Cont'd)

**REC'D MAY 03 2000**

5.2.4 Selection Of Facilities For Access Orders

- (A) When a customer places an Access Order, it may choose to utilize facilities previously purchased as a facility to a Hub. If the customer has a high capacity interface for use with Switched Access Service Interface Groups 6 and 9, or has a Special Access Service facility purchased to a Hub, the customer must request that specific channels be used to implement the Access Order. If a facility assignment is not specified by the customer, the Telephone Company will provide the service from available inventory as discussed in 5.3 following. (C)
- (B) For all other Access Orders, the option to request a transmission path or channel is not provided except as provided for under Special Facilities Routing as set forth in 11. following.

5.2.5 Minimum Period

- (A) Except as set forth in (B), (C), 7.4.4, 8.1.5(B), 8.3.5(A), 9.4(A) and 13.3.5(C)(1)(b), (c) and (d) following, the minimum period for which Access Service is provided and for which charges are applicable, is one month.
- (B) The minimum period for Switched Access Service Feature Group D is three months.
- (C) The minimum period for part-time Video and Program Audio Special Access Services is one day even though the service will be provided only for the duration of the event specified on the order (e.g., one-half hour, two hours, five hours, etc.).

**CANCELLED**

**AUG 12 2002**

**2nd RS 129  
Missouri Public Service Commission  
MISSOURI**

**Missouri Public  
Service Commission**

**FILED JUN 02 2000**

ISSUED:  
May 3, 2000

Richard D. Lawson  
State Executive, External Affairs

EFFECTIVE:  
June 2, 2000

RECEIVED

SEP 17 1992

MISSOURI  
Public Service Commission

ACCESS SERVICE

5. Ordering Options for Switched and Special Access Service (Cont'd)

5.2 Access Order (Cont'd)

5.2.4 Selection Of Facilities For Access Orders

- (A) When a customer places an Access Order, it may choose to utilize facilities previously purchased as a facility to a Hub. If the customer has a high capacity interface for use with Switched Access Service Interface Groups 3-10, or has a Special Access Service facility purchased to a Hub, the customer must request that specific channels be used to implement the Access Order. If a facility assignment is not specified by the customer, the Telephone Company will provide the service from available inventory as discussed in 5.3 following.
- (B) For all other Access Orders, the option to request a transmission path or channel is not provided except as provided for under Special Facilities Routing as set forth in 11. following.

5.2.5 Minimum Period

- (A) Except as set forth in (B), (C), 7.4.4, 8.1.5(B), 8.3.5(A), 9.4(A) and 13.3.5(C)(1)(b), (c) and (d) following, the minimum period for which Access Service is provided and for which charges are applicable, is one month.
- (B) The minimum period for Switched Access Service Feature Group D is three months.
- (C) The minimum period for part-time Video and Program Audio Special Access Services is one day even though the service will be provided only for the duration of the event specified on the order (e.g., one-half hour, two hours, five hours, etc.).

CANCELLED

JUN 02 2000  
By *JST RP 129*  
Public Service Commission  
MISSOURI

FILED

NOV 7 1992

ISSUED:  
September 17, 1992

BY: John L. Roe  
Vice President - Administration  
5454 West 110th Street  
Overland Park, Kansas 66211

MO. PUBLIC SERVICE COMMISSION  
EFFECTIVE:  
~~September 17, 1992~~  
NOV 7 1992

ACCESS SERVICE

RECEIVED

SEP 17 1992

5. Ordering Options for Switched and Special Access Service (Cont'd)

MISSOURI  
Public Service Commission

5.2 Access Order (Cont'd)

5.2.5 Minimum Period (Cont'd)

- (D) Service Rearrangements as set forth in 6.7.1(C)(3) and 7.4.1(C)(3) following for Switched and Special Access Services respectively, may be made without a change in minimum period requirements.
- (E) Changes other than those identified in 6.7.1(C)(3) or 7.4.1(C)(3) following will be treated as a discontinuance of the existing service and an installation of a new service. All associated nonrecurring charges will apply for the new service. A new minimum period will be established for the new service. The customer will also remain responsible for all outstanding minimum period obligations associated with the disconnected service.

The changes listed below are those which will be treated as a discontinuance and installation of service and for which a new minimum period will be established.

- (1) A change of customer of record (i.e., Access Service is provided to and billed to a different entity).
- (2) A move to a different building as set forth in 6.7.7(B) or 7.4.5(B) following.
- (3) A change in type of service (i.e., Switched Access to Special Access, one type of Special Access to another, or one type of Switched Access Feature Group to another except as set forth in 6.7.6 following).
- (4) A change in the type of Special Access Service Channel termination.
- (5) A change in Switched Access Service or Directory Assistance Service Interface Group.
- (6) Change in Switched Access Service traffic type.
- (7) Change from two-point to multipoint Special Access Service or from multipoint to two-point Special Access Service.

5.2.6 Minimum Period Charges

When Access Service is disconnected at the customer's request prior to the expiration of the minimum period, charges are applicable for the balance of the minimum period. A disconnect constitutes facilities being returned to available inventory.

FILED

NOV 7 1992

MO. PUBLIC SERVICE COMM.

EFFECTIVE:

~~SEP 17, 1992~~

NOV 7 1992

ISSUED:  
September 17, 1992

BY: John L. Roe  
Vice President - Administration  
5454 West 110th Street  
Overland Park, Kansas 66211





RECEIVED

SEP 17 1992

MISSOURI  
Public Service Commission

ACCESS SERVICE

5. Ordering Options for Switched and Special Access Service (Cont'd)

5.2 Access Order (Cont'd)

5.2.6 Minimum Period (Cont'd)

The Minimum Period Charge for services provided with a one month minimum period will be determined as follows:

- (A) For Switched Access Service, the charge for a month or fraction thereof is equal to the applicable minimum monthly charge for the capacity as set forth in 6.7.4 following.
- (B) For Special Access Service, the charge for a month or fraction thereof is the applicable monthly rates for the service as set forth in 7.5 following.

The Minimum Period Charge for Feature Group D Switched Access Service will be determined as set forth in 2.4.2 (B) preceding.

The Minimum Period Charge for part-time Video and Program Audio Special Access Services is the applicable daily rate for the service as set forth in 7.5 following.

All applicable nonrecurring charges for the service will be billed in addition to the Minimum Period Charge.

5.2.7 Shared Use Facilities

Shared Use (i.e., Switched and Special Access Services provided over the same analog or digital high capacity facilities) is allowed. Shared use facilities to a Hub will be ordered and provided as Special Access Service. While shared use is allowed, individual services utilizing these facilities must be ordered either as Switched Access Service or Special Access Service. When placing the order for the individual service(s), the customer must specify a channel assignment for each service ordered.

CANCELLED

AUG 12 2002  
KRS 131  
Public Service Commission  
MISSOURI

FILED

NOV 7 1992

MO. PUBLIC SERVICE COMM.  
EFFECTIVE:

~~Cancelled by order of 1992~~  
NOV 7 1992

ISSUED:  
September 17, 1992

BY: John L. Roe  
Vice President - Administration  
5454 West 110th Street  
Overland Park, Kansas 66211



UNITED TELEPHONE COMPANY  
OF MISSOURI

Original Page 132

RECEIVED

SEP 17 1992

ACCESS SERVICE

5. Ordering Options for Switched and Special Access Service (Cont'd)

MISSOURI  
Public Commission

5.3 Available Inventory

Available inventory is limited and does not include facilities previously ordered. The Telephone Company will make every reasonable effort to maintain sufficient available inventory to provide Access Service in accordance with customers' requested service date intervals. To the extent that service can be provided, Access Orders will be satisfied from available inventory.

5.4 Planned Facilities Order

Reserved for Future Use

FILED

NOV 7 1992

MO. PUBLIC SERVICE BOARD  
EFFECTIVE:

~~September 17, 1992~~

NOV 7 1992

ISSUED:  
September 17, 1992

BY: John L. Roe  
Vice President - Administration  
5454 West 110th Street  
Overland Park, Kansas 66211

SPRINT MISSOURI, INC.  
d/b/a SPRINT

Second Revised Page 133  
Cancels First Revised Page 133

Missouri Public

ACCESS SERVICE

REC'D JAN 07 2002

5. Ordering Options for Switched and Special Access Service (Cont'd)

5.5 Switched Access Service Minimum Capacity Requirements Service Commission

5.5.1 When Switched Access Service Access Connections are ordered under Access Orders, they will be provided subject to the provisions set forth in 5.1.1 preceding and in 5.5.2 through 5.5.7 following.

5.5.2 There is no minimum capacity for Interface Groups 1 and 2. The minimum capacity provided for Interface Groups 6 and 9, and for which charges are applicable, are set forth in 5.5.6 following.

5.5.3 *Reserved For Future Use*

(C)  
(D)  
|  
(D)

5.5.4 When a customer requests analog or digital Interface Groups 6 and 9, the customer is required to order at a minimum, sufficient capacity to utilize 70% of the channels.

5.5.5 For the purpose of administering the minimum capacity provisions, Access Orders for Access Connection Interface Groups for different Feature Groups may be grouped together if the facilities provided for all the connections are the same and terminate in the same facilities terminal in the same Telephone Company access tandem or end office.

Missouri Public

FILED FEB 07 2002

Service Commission

ISSUED:  
January 7, 2002

Richard D. Lawson  
State Executive, External Affairs  
319 Madison  
Jefferson City, MO 65101

EFFECTIVE:  
February 7, 2002

SPRINT MISSOURI, INC.  
d/b/a SPRINT

First Revised Page 133  
Cancels Original Page 133  
**Missouri Public  
Service Commission**

ACCESS SERVICE

REC'D MAY 03 2000

5. Ordering Options for Switched and Special Access Service (Cont'd)

5.5 Switched Access Service Minimum Capacity Requirements

- 5.5.1 When Switched Access Service Access Connections are ordered under Access Orders, they will be provided subject to the provisions set forth in 5.1.1 preceding and in 5.5.2 through 5.5.7 following.
- 5.5.2 There is no minimum capacity for Interface Groups 1 and 2. The minimum capacity provided for Interface Groups 6 and 9, and for which charges are applicable, are set forth in 5.5.6 following. (C)
- 5.5.3 When additional busy hour minutes of capacity are ordered, they may be provided using in service Access Connection Interface Groups. Such busy hour minutes of capacity, up to and including the number that brings the Interface Group to its designated capacity, will be provided without being subject to the minimum capacity provisions as set forth in 5.5.6 following. Any additional busy hour minutes of capacity ordered will be subject to the minimum capacity provisions.
- 5.5.4 When a customer requests analog or digital Interface Groups 6 and 9, the customer is required to order at a minimum, sufficient capacity to utilize 70% of the channels. (C)
- 5.5.5 For the purpose of administering the minimum capacity provisions, Access Orders for Access Connection Interface Groups for different Feature Groups may be grouped together if the facilities provided for all the connections are the same and terminate in the same facilities terminal in the same Telephone Company access tandem or end office.

**CANCELLED**

FEB 07 2002

2ND R P 133  
**Public Service Commission  
MISSOURI**

**Missouri Public  
Service Commission**

FILED JUN 02 2000

ISSUED:  
May 3, 2000

Richard D. Lawson  
State Executive, External Affairs

EFFECTIVE:  
June 2, 2000

UNITED TELEPHONE COMPANY  
OF MISSOURI

Original Page 133

**RECEIVED**

SEP 17 1992

MISSOURI  
Public Service Commission

ACCESS SERVICE

5. Ordering Options for Switched and Special Access Service (Cont'd)

5.5 Switched Access Service Minimum Capacity Requirements

- 5.5.1 When Switched Access Service Access Connections are ordered under Access Orders, they will be provided subject to the provisions set forth in 5.1.1 preceding and in 5.5.2 through 5.5.7 following.
- 5.5.2 There is no minimum capacity for Interface Groups 1 and 2. The minimum capacity provided for Interface Groups 3 through 10, and for which charges are applicable, are set forth in 5.5.6 following.
- 5.5.3 When additional busy hour minutes of capacity are ordered, they may be provided using in service Access Connection Interface Groups. Such busy hour minutes of capacity, up to and including the number that brings the Interface Group to its designated capacity, will be provided without being subject to the minimum capacity provisions as set forth in 5.5.6 following. Any additional busy hour minutes of capacity ordered will be subject to the minimum capacity provisions.
- 5.5.4 When a customer requests analog or digital Interface Groups 3 through 10, the customer is required to order at a minimum, sufficient capacity to utilize 70% of the channels.
- 5.5.5 For the purpose of administering the minimum capacity provisions, Access Orders for Access Connection Interface Groups for different Feature Groups may be grouped together if the facilities provided for all the connections are the same and terminate in the same facilities terminal in the same Telephone Company access tandem or end office.

**CANCELLED**

JUN 02 2000

By 1st RP 133  
Public Service Commission  
MISSOURI

**FILED**

NOV 7 1992

ISSUED:  
September 17, 1992

BY: John L. Roe  
Vice President - Administration  
5454 West 110th Street  
Overland Park, Kansas 66211

MO. PUBLIC SERVICE COMM.  
EFFECTIVE:  
~~October 17, 1992~~  
NOV 7 1992

SPRINT MISSOURI, INC.  
d/b/a SPRINT

First Revised Page 134  
Cancels Original Page 134

Missouri Public

ACCESS SERVICE

REC'D JAN 07 2002

5. Ordering Options for Switched and Special Access Service (Cont'd)

5.5 Switched Access Service Minimum Capacity Requirements (Cont'd) Service Commission

5.5.6 The following table provides the total capacity of the interface and the thresholds for minimum order requirements.

<u>Interface Type</u>	<u>Interface Name</u>	<u>Total Capacity (Channels)</u>	<u>Minimum Capacity (Channels)</u>
Analog	Group	12	9
Analog	Supergroup	60	42
Analog	Mastergroup	600	420
Digital	DS1	24	17
Digital	DS1C	48	34
Digital	DS3	672	471

(D)  
(D)

The Telephone Company will not provide these Interface Groups when less than 70% of the capacity is ordered. For purposes of grouping, as set forth in 5.5.5 preceding, it shall be assumed that Feature Group A, B, C, or D minutes may be combined.

5.5.7 When Switched Access Service provided from available inventory is disconnected, and the disconnect causes the in service capacity to fall below the minimum requirements, the Telephone Company will, at the option of the customer:

- (A) Disconnect all the service subject to the minimum capacity requirements, and all appropriate charges will apply, or
- (B) Move the remaining in service capacity to a lesser capacity interface.

Missouri Public

FILED FEB 07 2002

Service Commission

ISSUED:  
January 7, 2002

Richard D. Lawson  
State Executive, External Affairs  
319 Madison  
Jefferson City, MO 65101

EFFECTIVE:  
February 7, 2002

UNITED TELEPHONE COMPANY  
OF MISSOURI

RECEIVED

SEP 17 1992

ACCESS SERVICE

5. Ordering Options for Switched and Special Access Service (Cont'd) MISSOURI  
Public Service Commission

5.5 Switched Access Service Minimum Capacity Requirements (Cont'd)

5.5.6 The following table provides the total capacity of the interface and the thresholds for minimum order requirements.

<u>Interface Type</u>	<u>Interface Name</u>	<u>Total Capacity (Channels)</u>	<u>Minimum Capacity (Channels)</u>
Analog	Group	12	9
Analog	Supergroup	60	42
Analog	Mastergroup	600	420
Digital	DS1	24	17
Digital	DS1C	48	34
Digital	DS2	96	68
Digital	DS3	672	471
Digital	DS4	4032	2823

The Telephone Company will not provide these Interface Groups when less than 70% of the capacity is ordered. For purposes of grouping, as set forth in 5.5.5 preceding, it shall be assumed that Feature Group A, B, C, or D minutes may be combined.

5.5.7 When Switched Access Service provided from available inventory is disconnected, and the disconnect causes the in service capacity to fall below the minimum requirements, the Telephone Company will, at the option of the customer:

- (A) Disconnect all the service subject to the minimum capacity requirements, and all appropriate charges will apply, or
- (B) Move the remaining in service capacity to a lesser capacity interface.

CANCELLED

FEB 07 2002  
1st RP 134  
Public Service Commission  
MISSOURI

FILED

NOV 7 1992

MO. PUBLIC SERVICE COMM.  
EFFECTIVE:

ISSUED:  
September 17, 1992

BY: John L. Roe  
Vice President - Administration  
5454 West 110th Street  
Overland Park, Kansas 66211

~~NOV 7 1992~~  
NOV 7 1992



UNITED TELEPHONE COMPANY  
OF MISSOURI

Original Page 135

RECEIVED

SEP 17 1992

ACCESS SERVICE

5. Ordering Options for Switched and Special Access Service (Cont'd)

MISSOURI  
Public Service Commission

5.6 Access Order Standard Intervals

The Standard Intervals, as set forth following, will be used for all Access Orders for Special Access Services of the same channel type with the same requested service date and all Switched Access Services with the same type Interface Group and/or Feature Group with the same requested service date.

The Standard Intervals are subject to the following conditions:

- The Standard Interval is the sum of the intervals from (1) The Application Date (APP) to the Design Layout Report Date (DLRD) and, (2) the Confirming Design Layout Report Date (CDLRD) to the Service Date (DD). These dates are defined in 5.2.3(C)(4)(b) preceding.
- The period between the design Layout Report Date (DLRD) and the Confirming Design Layout Report Date (CDLRD) is controlled by the customer, but is agreed upon by the customer and the Telephone Company prior to the Application Date. This period is limited to a maximum of 5 days.
- Service dates for items and services not included in the Standard intervals will be negotiated.
- Regardless of how many separate orders are placed at the same time for service between the same locations and with the same service date, if more than 10 services of the same type are involved as described preceding, the interval will be considered as negotiable even though separate orders reflect quantities that qualify as Standard Intervals.

FILED

NOV 7 1992

MO. PUBLIC SERVICE COMM.

EFFECTIVE:

~~Effective 09/17/92~~  
NOV 7 1992

ISSUED:  
September 17, 1992

BY: John L. Roe  
Vice President - Administration  
5454 West 110th Street  
Overland Park, Kansas 66211

Cancelled

SPRINT MISSOURI, INC.  
d/b/a SPRINT

Second Revised Page 136  
Cancels First Revised Page 136

ACCESS SERVICE

5. Ordering Options for Switched and Special Access Service (Cont'd)

5.6 Access Order Standard Intervals (Cont'd)

- Access Service Standard Intervals in working days, are as follows.

<u>SERVICE</u>	<u>APP-DLRD</u>	<u>CDLRD-DD</u>	<u>STD INT</u>
----------------	-----------------	-----------------	----------------

Special Access Service

1. Reserved For Future Use

Missouri Public  
Service Commission

REC'D FEB 09 2000

2. Reserved For Future Use

(C)

(D)

(D)

Missouri Public  
Service Commission

FILED MAR 10 2000

ISSUED:  
February 9, 2000

Richard D. Lawson  
State Executive, External Affairs

EFFECTIVE:  
March 10, 2000

SPRINT MISSOURI, INC.  
d/b/a SPRINT

First Revised Page 136  
Cancels Original Page 136  
Service Commission

ACCESS SERVICE

REC'D SEP 10 1999

5. Ordering Options for Switched and Special Access Service (Cont'd)

5.6 Access Order Standard Intervals (Cont'd)

- Access Service Standard Intervals in working days, are as follows.

<u>SERVICE</u>	<u>APP-DLRD</u>	<u>CDLRD-DD</u>	<u>STD INT</u>
----------------	-----------------	-----------------	----------------

Special Access Service

1. Reserved For Future Use

(C)

(D)

(D)

2. Telegraph Grade Service

Two-Point

1 to 6 Services	8	11	19
7 to 12 Services	ICB	ICB	ICB
Over 12 Services	ICB	ICB	ICB

Multipoint

3 to 5 Points	13	11	24
6 to 10 Points	ICB	ICB	ICB
Over 10 Points	ICB	ICB	ICB

Optional Features,  
Add 5 Days

**CANCELLED**

MAR 10 2000

By *2nd RP 136*  
**Public Service Commission  
MISSOURI**

Missouri Public  
Service Commission

FILED OCT 15 1999

ISSUED:  
September 10, 1999

Richard D. Lawson  
State Executive, External Affairs

EFFECTIVE:



OCT 15 1999

UNITED TELEPHONE COMPANY  
OF MISSOURI

Original Page 136

**RECEIVED**

SEP 17 1992

ACCESS SERVICE

5. Ordering Options for Switched and Special Access Service (Cont'd)

5.6 Access Order Standard Intervals (Cont'd)

MISSOURI  
Public Service Commission

- Access Service Standard Intervals in working days, are as follows.

<u>SERVICE</u>	<u>APP-DLRD</u>	<u>CDLRD-DD</u>	<u>STD INT</u>
<u>Special Access Service</u>			
1. <u>Metallic Service</u>			
Two-Point			
1 to 6 Services	8	11	19
7 to 10 Services	ICB	ICB	ICB
Over 10 Service	ICB	ICB	ICB
Multipoint			
3 to 5 Points	13	11	24
6 to 10 Points	ICB	ICB	ICB
Over 10 Points	ICB	ICB	ICB
Optional Features Add 5 Days			
2. <u>Telegraph Grade Service</u>			
Two-Point			
1 to 6 Services	8	11	19
7 to 12 Services	ICB	ICB	ICB
Over 12 Services	ICB	ICB	ICB
Multipoint			
3 to 5 Points	13	11	24
6 to 10 Points	ICB	ICB	ICB
Over 10 Points	ICB	ICB	ICB
Optional Features, Add 5 Days			

**CANCELLED**

OCT 15 1999  
By 1st RSt 136  
Public Service Commission  
MISSOURI

**FILED**

NOV 7 1992

MO. PUBLIC SERVICE COMM.

ISSUED:  
September 17, 1992

BY: John L. Roe  
Vice President - Administration  
5454 West 110th Street  
Overland Park, Kansas 66211

EFFECTIVE:

~~September 17, 1992~~

NOV 7 1992

SPRINT MISSOURI, INC.  
d/b/a SPRINT

First Revised Page 137  
Cancels Original Page 137

ACCESS SERVICE

Missouri Public

5. Ordering Options for Switched and Special Access Service (Cont'd)

REC'D JUL 02 2002

5.6 Access Order Standard Intervals (Cont'd)

Service Commission

SERVICE	APP-DLRD	CDLRD-DD	STD INT
<u>Special Access Service (Cont'd)</u>			
3. <u>Voice Grade Service</u>			
Two-Point			
1 to 6 Services	8	11	19
7 to 10 Services	ICB	ICB	ICB
Over 12 Service	ICB	ICB	ICB
Multipoint			
3 to 5 Points	13	11	24
6 to 10 Points	ICB	ICB	ICB
Over 10 Points	ICB	ICB	ICB
Facility to A Hub (For 43A Carrier)			
1 to 6 Facilities	8	11	19
7 to 10 Facilities	ICB	ICB	ICB
Over 10 Facilities	ICB	ICB	ICB
Optional Features, Add 10 Days			

4. Reserved for Future Use

(D)

Missouri Public

(D)

FILED AUG 12 2002

Service Commission

ISSUED:  
July 2, 2002

Richard D. Lawson  
State Executive, External Affairs  
319 Madison  
Jefferson City, MO 65101

EFFECTIVE:

**AUG 12 2002**

UNITED TELEPHONE COMPANY  
OF MISSOURI

Original Page 137

**RECEIVED**

SEP 17 1992

MISSOURI  
Public Service Commission

ACCESS SERVICE

5. Ordering Options for Switched and Special Access Service (Cont'd)

5.6 Access Order Standard Intervals (Cont'd)

<u>SERVICE</u>	<u>APP-DLRD</u>	<u>CDLRD-DD</u>	<u>STD INT</u>
<u>Special Access Service</u> (Cont'd)			

3. Voice Grade Service

Two-Point

1 to 6 Services	8	11	19
7 to 10 Services	ICB	ICB	ICB
Over 12 Service	ICB	ICB	ICB

Multipoint

3 to 5 Points	13	11	24
6 to 10 Points	ICB	ICB	ICB
Over 10 Points	ICB	ICB	ICB

Facility to A Hub  
(For 43A Carrier)

1 to 6 Facilities	8	11	19
7 to 10 Facilities	ICB	ICB	ICB
Over 10 Facilities	ICB	ICB	ICB

Optional Features,  
Add 10 Days

4. Program Audio Service

Two-Point

1 to 6 Services	8	11	19
7 to 12 Services	ICB	ICB	ICB
Over 10 Service	ICB	ICB	ICB

Multipoint

3 to 5 Points	ICB	ICB	ICB
6 to 10 Points	ICB	ICB	ICB
Over 12 Points	ICB	ICB	ICB

Optional Features,  
Add 10 Days

**CANCELLED**

AUG 12 2002

LRS 137  
Public Service Commission  
MISSOURI

**FILED**

NOV 7 1992

ISSUED:  
September 17, 1992

BY: John L. Roe  
Vice President - Administration  
5454 West 110th Street  
Overland Park, Kansas 66211

MO. PUBLIC SERVICE COMMISSION  
EFFECTIVE:  
~~October 17, 1992~~  
NOV 7 1992



SPRINT MISSOURI, INC.  
d/b/a SPRINT

First Revised Page 138  
Cancels Original Page 138

ACCESS SERVICE

Missouri Public

5. Ordering Options for Switched and Special Access Service (Cont'd)

REC'D JUL 02 2002

5.6 Access Order Standard Intervals (Cont'd)

Service Commission

Special Access Service (Cont'd)

5. Reserved for Future Use

(D)

6. Reserved for Future Use

(D)

7. Reserved for Future Use

Missouri Public

FILED AUG 12 2002

Service Commission

ISSUED:  
July 2, 2002

Richard D. Lawson  
State Executive, External Affairs  
319 Madison  
Jefferson City, MO 65101

EFFECTIVE:

~~XXXXXXXXXX~~  
AUG 12 2002

Cancelled

April 30, 2007

Missouri Public

Service Commission

UNITED TELEPHONE COMPANY  
OF MISSOURI

Original Page 138

ACCESS SERVICE

RECEIVED

5. Ordering Options for Switched and Special Access Service (Cont'd)

SEP 17 1992

5.6 Access Order Standard Intervals (Cont'd)

MISSOURI  
Public Service Commission

Special Access Service (Cont'd)

5. Video Service

<u>SERVICE</u>	<u>APP-DLRD</u>	<u>CDLRD-DD</u>	<u>STD INT</u>
Two-Point			
1 to 3 Services	ICB	ICB	ICB
4 to 8 Services	ICB	ICB	ICB
Over 8 Services	ICB	ICB	ICB

6. Reserved for Future Use

7. Reserved for Future Use

CANCELLED

AUG 12 2002  
By LRS/38  
Public Service Commission  
MISSOURI

FILED

NOV 7 1992

ISSUED:  
September 17, 1992

BY: John L. Roe  
Vice President - Administration  
5454 West 110th Street  
Overland Park, Kansas 66211

MO. PUBLIC SERVICE COMM.  
EFFECTIVE:  
~~SEP 17 1992~~  
NOV 7 1992

SPRINT MISSOURI, INC.  
d/b/a SPRINT

First Revised Page 139  
Cancels Original Page 139

ACCESS SERVICE

5. Ordering Options for Switched and Special Access Service (Cont'd)

5.6 Access Order Standard Intervals (Cont'd)

	<u>SERVICE</u>	<u>APP-DLRD</u>	<u>CDLRD-DD</u>	<u>STD INT</u>
<u>Special Access Service</u> (Cont'd)				
8.	<u>Digital Data Service</u>			(T)
	Two-Point			
	1 to 3 Services	13.	11	24
	4 to 8 Services	ICB	ICB	ICB
	Over 8 Services	ICB	ICB	ICB
	Multipoint			
	3 to 5 Points	25	35	60
	6 to 10 Points	25	35	60
	Over 10 Points	25	35	60

Optional Features,  
Add 10 Days

9. High Capacity Service

(T)

	Two-Point			
	1 to 3 Services	35	25	60
	4 to 8 Services	ICB	ICB	ICB
	Over 8 Services	ICB	ICB	ICB
	Facility to A Hub (Group, Supergroup, Mastergroup)			
	1 to 3 Facilities	ICB	ICB	ICB
	4 to 8 Facilities	ICB	ICB	ICB
	Over 8 Facilities	ICB	ICB	ICB

Optional Features,  
Add 10 Days

(D)

ISSUED:  
September 10, 1999

Richard D. Lawson  
State Executive, External Affairs

~~EXECUTIVE:~~  
October 14, 1999

OCT 15 1999

UNITED TELEPHONE COMPANY  
OF MISSOURI

Original Page 139

ACCESS SERVICE

RECEIVED

5. Ordering Options for Switched and Special Access Service (Cont'd)

SEP 17 1992

5.6 Access Order Standard Intervals (Cont'd)

MISSOURI  
Public Service Commission

<u>SERVICE</u>	<u>APP-DLRD</u>	<u>CDLRD-DD</u>	<u>STD INT</u>
----------------	-----------------	-----------------	----------------

Special Access Service (Cont'd)

8. United Digilink<sup>SM</sup> Service

Two-Point

1 to 3 Services	13	11	24
4 to 8 Services	ICB	ICB	ICB
Over 8 Services	ICB	ICB	ICB

Multipoint

3 to 5 Points	25	35	60
6 to 10 Points	25	35	60
Over 10 Points	25	35	60

Optional Features,  
Add 10 Days

9. United TransLink<sup>SM</sup> and Other High Capacity Services

Two-Point

1 to 3 Services	35	25	60
4 to 8 Services	ICB	ICB	ICB
Over 8 Services	ICB	ICB	ICB

Facility to A Hub  
(Group, Supergroup,  
Mastergroup)

1 to 3 Facilities	ICB	ICB	ICB
4 to 8 Facilities	ICB	ICB	ICB
Over 8 Facilities	ICB	ICB	ICB

Optional Features,  
Add 10 Days

■ Registered service mark of United Telecommunications, Inc.

CANCELLED

OCT 15 1992  
157RS# 139  
Public Service Commission  
MISSOURI

NOV 7 1992

ISSUED:  
September 17, 1992

BY: John L. Roe  
Vice President - Administration  
5454 West 110th Street  
Overland Park, Kansas 66211

EFFECTIVE:

NOV 7 1992

UNITED TELEPHONE COMPANY  
OF MISSOURI

Original Page 140

RECEIVED

SEP 17 1992

ACCESS SERVICE

5. Ordering Options for Switched and Special Access Service (Cont'd)

5.6 Access Order Standard Intervals (Cont'd)

MISSOURI  
Public Service Commission

<u>SERVICE</u>	<u>APP-DLRD</u>	<u>CDLRD-DD</u>	<u>STD INT</u>
10. <u>WATS Access Line Service</u>			
Two-Point			
1 to 6 Services	8	11	29
7 to 10 Services	ICB	ICB	ICB
Over 10 Service	ICB	ICB	ICB
Optional Features, Add 10 Days			

ISSUED:  
September 17, 1992

BY: John L. Roe  
Vice President - Administration  
5454 West 110th Street  
Overland Park, Kansas 66211

EFFECTIVE:

~~September 17, 1992~~  
NOV 7 ' 1992

Cancelled



SPRINT MISSOURI, INC.  
d/b/a SPRINT

First Revised Page 141  
Cancels Original Page 141

Missouri Public

ACCESS SERVICE

REC'D JAN 07 2002

5. Ordering Options for Switched and Special Access Service (Cont'd)

Service Commission

5.6 Access Order Standard Intervals (Cont'd)

	<u>SERVICE</u>	<u>APP-DLRD</u>	<u>CDLRD-DD</u>	<u>STD INT</u>
<u>Special Access Service</u>				
1.	<u>Feature Group A</u>			
	1 to 3 Lines	8	11	19
	4 to 10 Lines	ICB	ICB	ICB
	Over 10 Lines	ICB	ICB	ICB
	Optional Features, Add 5 Days			
2.	<u>Feature Group B</u>			
	1 to 3 Trunks	38	22	60
	4 to 7 Trunks	ICB	ICB	ICB
	Over 7 Trunks	ICB	ICB	ICB
	Optional Features, Add 5 Days			

(D)  
|  
(D)

Missouri Public

FILED FEB 07 2002

Service Commission

ISSUED:  
January 7, 2002

Richard D. Lawson  
State Executive, External Affairs  
319 Madison  
Jefferson City, MO 65101

EFFECTIVE:  
February 7, 2002

UNITED TELEPHONE COMPANY  
OF MISSOURI

Original Page 141

ACCESS SERVICE

RECEIVED

SEP 17 1992

5. Ordering Options for Switched and Special Access Service (Cont'd)

MISSOURI  
Public Service Commission

5.6 Access Order Standard Intervals (Cont'd)

<u>SERVICE</u>	<u>APP-DLRD</u>	<u>CDLRD-DD</u>	<u>STD INT</u>
<u>Special Access Service</u>			
1. <u>Feature Group A</u>			
1 to 3 Lines	8	11	19
4 to 10 Lines	ICB	ICB	ICB
Over 10 Lines	ICB	ICB	ICB
Optional Features, Add 5 Days			
2. <u>Feature Group B</u>			
1 to 3 Trunks	38	22	60
4 to 7 Trunks	ICB	ICB	ICB
Over 7 Trunks	ICB	ICB	ICB
Optional Features, Add 5 Days			
3. <u>Feature Group C</u>			
1 to 110 BHMC	22	38	60
111 to 120 BHMC	ICB	ICB	ICB
Over 120 BHMC	ICB	ICB	ICB
Optional Features, Add 5 Days			

**CANCELLED**

FEB 07 2002

By *JS/RP 141*  
Public Service Commission  
MISSOURI

FILED

NOV 7 1992

MISSOURI PUBLIC SERVICE COMMISSION

ISSUED:  
September 17, 1992

BY: John L. Roe  
Vice President - Administration  
5454 West 110th Street  
Overland Park, Kansas 66211

EFFECTIVE:  
~~October 27, 1992~~  
NOV 7 1992

SPRINT MISSOURI, INC.  
d/b/a SPRINT

Second Revised Page 142  
Cancels First Revised Page 142

Missouri Public

ACCESS SERVICE

REC'D JAN 07 2002

5. Ordering Options for Switched and Special Access Service (Cont'd)

Service Commission

5.6 Access Order Standard Interval (Cont'd)

<u>SERVICE</u>	<u>APP-DLRD</u>	<u>CDLRD-DD</u>	<u>STD INT</u>
<u>Switched Access Service (Cont'd)</u>			

3. Feature Group C & D

(T)

1 to 3 Trunks	38	22	60
4 to 10 Trunks	ICB	ICB	ICB
Over 10 Trunks	ICB	ICB	ICB

(D)

(D)

With New High Capacity  
Interface Group (6 and 9)  
Add 20 Days

Optional Features  
Add 10 Days

(D)

(D)

Missouri Public

FILED FEB 07 2002

Service Commission

ISSUED:  
January 7, 2002

Richard D. Lawson  
State Executive, External Affairs  
319 Madison  
Jefferson City, MO 65101

EFFECTIVE:  
February 7, 2002

Cancelled

April 30, 2007  
Missouri Public  
Service Commission

SPRINT MISSOURI, INC.  
d/b/a SPRINT

First Revised Page 142  
Cancels Original Page 142

ACCESS SERVICE

5. Ordering Options for Switched and Special Access Service (Cont'd)

5.6 Access Order Standard Interval (Cont'd)

<u>SERVICE</u>	<u>APP-DLRD</u>	<u>CDLRD-DD</u>	<u>STD INT</u>
<u>Switched Access Service</u> (Cont'd)			
4. <u>Feature Group D</u>			
1 to 3 Trunks	38	22	60
4 to 10 Trunks	ICB	ICB	ICB
Over 10 Trunks	ICB	ICB	ICB
1 to 120 BHMC	ICB	ICB	ICB
121 to 150 BHMC	ICB	ICB	ICB
Over 150 BHMC	ICB	ICB	ICB

**Missouri Public Service Commission**

REC'D MAY 03 2000

With New High Capacity  
Interface Group (6 and 9)  
Add 20 Days

(C)

Optional Features,  
Add 10 Days

Directory Assistance Service

1 to 15 BHMC	44	16	60
16 to 30 BHMC	ICB	ICB	ICB
Over 30 BHMC	ICB	ICB	ICB

With New High Capacity  
Interface Group (6 and 9)  
Add 20 Days

(C)

**CANCELLED**

FEB 07 2002  
By 2nd RP142  
Public Service Commission  
MISSOURI

**Missouri Public Service Commission**

FILED JUN 02 2000

ISSUED:  
May 3, 2000

Richard D. Lawson  
State Executive, External Affairs

EFFECTIVE:  
June 2, 2000

UNITED TELEPHONE COMPANY  
OF MISSOURI

Original Page 142

RECEIVED

SEP 17 1992

ACCESS SERVICE

5. Ordering Options for Switched and Special Access Service (Cont'd) MISSOURI  
Public Service Commission

5.6 Access Order Standard Interval (Cont'd)

<u>SERVICE</u>	<u>APP-DLRD</u>	<u>CDLRD-DD</u>	<u>STD INT</u>
<u>Switched Access Service</u> (Cont'd)			

4. Feature Group D

1 to 3 Trunks	38	22	60
4 to 10 Trunks	ICB	ICB	ICB
Over 10 Trunks	ICB	ICB	ICB
1 to 120 BHMC	ICB	ICB	ICB
121 to 150 BHMC	ICB	ICB	ICB
Over 150 BHMC	ICB	ICB	ICB

With New High Capacity  
Interface Group (3-10)  
Add 20 Days

Optional Features,  
Add 10 Days

Directory Assistance Service

1 to 15 BHMC	44	16	60
16 to 30 BHMC	ICB	ICB	ICB
Over 30 BHMC	ICB	ICB	ICB

With New High Capacity  
Interface Group (3-10)  
Add 20 Days

CANCELLED

JUN 02 2000

By *1st RP 142*  
Public Service Commission  
MISSOURI

FILED

NOV 7 1992

MO. PUBLIC SERVICE COMMISSION

EFFECTIVE:

~~September 17, 1992~~

NOV 7 1992

ISSUED:  
September 17, 1992

BY: John L. Roe  
Vice President - Administration  
5454 West 110th Street  
Overland Park, Kansas 66211



## ACCESS SERVICE

6. Switched Access Service6.1 General

Switched Access Service, which is available to customers for their use in furnishing their services to end users, provides a two-point electrical communications path between a customer's premises and an end user's premises. It provides for the use of common terminating, switching and trunking facilities and common subscriber plant of the Telephone Company. Switched Access Service provides for the ability to originate calls from an end user's premises to a customer's premises, and to terminate calls from a customer's premises to an end user's premises in the local exchange where it is provided. Specific references to material describing the elements of Switched Access Service are provided in 6.1.1 and 6.1.3 following.

Rates and charges for Switched Access Service depend generally on its use by the customer, i.e., for MTS or WATS services, MTS-WATS equivalent services, or other services (e.g., foreign exchange service), and whether it is provided in a Telephone Company end office that is equipped to provide equal access (Feature Group D Access, described in 6.1.1(D) following). Rates and charges for Switched Access Service are set forth in 6.8 following. The application of rates for Switched Access Service is described in 6.7 following. Rates and charges for services other than Switched Access Service, e.g., a customer's interLATA and intraLATA toll message service, may also be applicable when Switched Access Service is used in conjunction with these other services. Descriptions of such applicability are provided in 6.2.1(A)(7), 6.2.1(B)(4), 6.2.2(A)(5), 6.2.2(B)(4), 6.2.3(A)(5), 6.2.4(A)(4), 6.7.10 and 6.7.12 following.

ISSUED:  
March 30, 2007

Mark D. Harper  
Director - State Regulatory  
5454 W. 110th Street  
Overland Park, Kansas 66211

EFFECTIVE:  
April 30, 2007

CANCELLED  
May 30, 2021  
Missouri Public  
Service Commission  
JI-2021-0191

**Filed**  
Missouri Public  
Service Commission

UNITED TELEPHONE COMPANY  
OF MISSOURI

Original Page 143

RECEIVED

SEP 17 1992

## ACCESS SERVICE

MISSOURI  
Public Service Commission

6. Switched Access Service6.1 General

Switched Access Service, which is available to customers for their use in furnishing their services to end users, provides a two-point electrical communications path between a customer's premises and an end user's premises. It provides for the use of common terminating, switching and trunking facilities and common subscriber plant of the Telephone Company. Switched Access Service provides for the ability to originate calls from an end user's premises to a customer's premises, and to terminate calls from a customer's premises to an end user's premises in the local exchange where it is provided. Specific references to material describing the elements of Switched Access Service are provided in 6.1.1 and 6.1.3 following.

Rates and charges for Switched Access Service depend generally on its use by the customer, i.e., for MTS or WATS services, MTS-WATS equivalent services, or other services (e.g., foreign exchange service), and whether it is provided in a Telephone Company end office that is equipped to provide equal access (Feature Group D Access, described in 6.1.1(D) following). Rates and charges for Switched Access Service are set forth in 6.8 following. The application of rates for Switched Access Service is described in 6.7 following. Rates and charges for services other than Switched Access Service, e.g., a customer's interLATA and intraLATA toll message service, may also be applicable when Switched Access Service is used in conjunction with these other services. Descriptions of such applicability are provided in 6.2.1(A)(7), 6.2.1(B)(4), 6.2.2(A)(5), 6.2.2(B)(4), 6.2.3(A)(5), 6.2.4(A)(4), 6.7.10 and 6.7.12 following.

ISSUED:  
September 17, 1992

BY: John L. Roe  
Vice President - Administration  
5454 West 110th Street  
Overland Park, Kansas 66211

EFFECTIVE:

~~September 17, 1992~~

NOV 7 1992

Cancelled

April 30, 2007  
Missouri Public  
Service Commission

RECEIVED

ACCESS SERVICE

6. Switched Access Service (Cont'd)

MAR 27 1996

6.1 General (Cont'd)

MISSOURI

6.1.1 Feature Group Arrangements and Manner of Provision of Missouri Public Service Commission

Switched Access Service is provided in seven service categories of standard and optional features called Feature Groups A through D, Interim 500 Access Service, TFC Access Service, and 900 Access Service. They are differentiated by their technical characteristics, e.g., line side vs. trunk side connection at the Telephone Company entry switch, and the manner in which an end user accesses them in originating calls, e.g., with or without an access code. Following is a brief description of each Feature Group arrangement.

(T)

(A) Feature Group A (FGA)

FGA Access provides line side access to Telephone Company end office switches with an associated seven digit local telephone number for the customer's use in originating and terminating communications to an Interexchange Carrier's intrastate service or a customer provided intrastate communications capability. The customer must specify the Interexchange Carrier to which the FGA service is connected, or in the alternative, specify the means by which the FGA access communications is transported to another exchange. FGA Access may also be used to terminate TFC Access Service Calls. FGA Access is not offered for use in terminating FGC and FGD originating communications. A more detailed description of FGA Access is provided in 6.2.1 following.

(T)

(B) Feature Group B (FGB)

FGB Access provides trunk side access to Telephone Company end office switches with an associated uniform 950-0XXX or 950-1XXX access code for the customer's use in originating and terminating communications to an Interexchange Carrier's intrastate service or a customer provided intrastate communications capability. The customer must specify the Interexchange Carrier to which the FGB service is connected, or in the alternative, specify the means by which the FGB access communications is transported to another exchange. FGB Access may also be used to originate TFC Access Service until such time as FGD becomes available in the end office.

(T)

MISSOURI

MAR 29 1996

ISSUED:  
March 27, 1996

BY: John L. Roe  
Vice President - Carrier and Regulatory Services  
5454 West 110th Street  
Overland Park, Kansas 66211

EFFECTIVE:  
April 29, 1996

Cancelled

April 30, 2007  
Missouri Public  
Service Commission



UNITED TELEPHONE COMPANY  
OF MISSOURI

First Revised Page 144  
Cancels Original Page 144

ACCESS SERVICE

RECEIVED

6. Switched Access Service (Cont'd)

6.1 General (Cont'd)

FEB 11 1995

6.1.1 Feature Group Arrangements and Manner of Provision

Switched Access Service is provided in seven ~~categories~~ **700 PUBLIC SERVICE COMM.** categories of standard and optional features called Feature Groups A through D, Interim 500 Access Service, 800 Access Service, and 900 Access Service. They are differentiated by their technical characteristics, e.g., line side vs. trunk side connection at the Telephone Company entry switch, and the manner in which an end user accesses them in originating calls, e.g., with or without an access code. Following is a brief description of each Feature Group arrangement.

(C)  
(N)  
(N)

(A) Feature Group A (FGA)

FGA Access provides line side access to Telephone Company end office switches with an associated seven digit local telephone number for the customer's use in originating and terminating communications to an Interexchange Carrier's intrastate service or a customer provided intrastate communications capability. The customer must specify the Interexchange Carrier to which the FGA service is connected, or in the alternative, specify the means by which the FGA access communications is transported to another exchange. FGA Access may also be used to terminate 800 Access Service Calls. FGA Access is not offered for use in terminating FGC and FGD originating communications. A more detailed description of FGA Access is provided in 6.2.1 following.

(B) Feature Group B (FGB)

FGB Access provides trunk side access to Telephone Company end office switches with an associated uniform 950-0XXX or 950-1XXX access code for the customer's use in originating and terminating communications to an Interexchange Carrier's intrastate service or a customer provided intrastate communications capability. The customer must specify the Interexchange Carrier to which the FGB service is connected, or in the alternative, specify the means by which the FGB access communications is transported to another exchange. FGB Access may also be used to originate 800 Access Service until such time as FGD becomes available in the end office.

CANCELLED

FILED

APR 29 1995  
By 2nd P.S. # 144  
Public Service Commission  
MISSOURI

FEB 11 1995

MISSOURI  
Public Service Commission

ISSUED:  
January 11, 1995

BY: John L. Roe  
Vice President - Carrier and Regulatory Services  
5454 West 110th Street  
Overland Park, Kansas 66211

EFFECTIVE:  
February 11, 1995

UNITED TELEPHONE COMPANY  
OF MISSOURI

Original Page 144  
**RECEIVED**

ACCESS SERVICE

SEP 17 1992

6. Switched Access Service (Cont'd)

MISSOURI  
Public Service Commission

6.1 General (Cont'd)

6.1.1 Feature Group Arrangements and Manner of Provision

Switched Access Service is provided in four service categories of standard and optional features called Feature Groups. These are differentiated by their technical characteristics, e.g., line side vs. trunk side connection at the Telephone Company entry switch, and the manner in which an end user accesses them in originating calls, e.g., with or without an access code. Following is a brief description of each Feature Group arrangement.

(A) Feature Group A (FGA)

FGA Access provides line side access to Telephone Company end office switches with an associated seven digit local telephone number for the customer's use in originating and terminating communications to an Interexchange Carrier's intrastate service or a customer provided intrastate communications capability. The customer must specify the Interexchange Carrier to which the FGA service is connected, or in the alternative, specify the means by which the FGA access communications is transported to another exchange. FGA Access may also be used to terminate 800 Access Service Calls. FGA Access is not offered for use in terminating FGC and FGD originating communications. A more detailed description of FGA Access is provided in 6.2.1 following.

CANCELLED  
FEB 11 1995  
BY Let R.S. #144  
Public Service Commission  
MISSOURI

(B) Feature Group B (FGB)

FGB Access provides trunk side access to Telephone Company end office switches with an associated uniform 950-0XXX or 950-1XXX access code for the customer's use in originating and terminating communications to an Interexchange Carrier's intrastate service or a customer provided intrastate communications capability. The customer must specify the Interexchange Carrier to which the FGB service is connected, or in the alternative, specify the means by which the FGB access communications is transported to another exchange. FGB Access may also be used to originate 800 Access Service until such time as FGD becomes available in the end office.

NOV 7 1992

ISSUED:  
September 17, 1992

BY: John L. Roe  
Vice President - Administration  
5454 West 110th Street  
Overland Park, Kansas 66211

EFFECTIVE:  
~~October 1, 1992~~  
NOV 7 1992



ACCESS SERVICE

RECEIVED

6. Switched Access Service (Cont'd)

JUL 02 1998

6.1 General (Cont'd)

6.1.1 Feature Group Arrangements and Manner of Provision (Cont'd) MO. PUBLIC SERVICE COMM

(B) Feature Group B (Cont'd)

FGB Access may also be used to terminate TFC Access service calls. A more detailed description of FGB Access is provided in 6.2.2 following.

(C) Feature Group C (FGC)

FGC Access, which is available only to providers of MTS and WATS, provides trunk side access to Telephone Company end office switches for the customer's use in originating and terminating communications. FGC Access may also be used to originate and terminate TFC Access Service. This service is available in all end offices which are not equipped for Feature Group D End Office Switching. Existing FGC Access will be converted to Feature Group D Access when it becomes available in an end office. The WATS Access Line optional feature set forth in 7.2.11 (A) may be ordered separately by a customer other than the customer which orders the FGC Switched Access Service (i.e., a provider of MTS and WATS). WATS Access Lines are ordered as set forth in 5.2 preceding. A more detailed description of FGC Access is provided in 6.2.3 following.

(D) Feature Group D (FGD)

FGD Access, which is available to all customers, provides trunk side access to Telephone Company end office switches with an associated uniform 101XXXX access code for the customer's use in originating and terminating communications. The WATS Access Line optional feature set forth in 7.2.11 (D) may be ordered separately by a customer other than the customer which orders the FGD Switched Access Service. WATS Access Lines are ordered as set forth in 5.2 preceding. A more detailed description of FGD Access is provided in 6.2.4 following.

(CI)

FILED

AUG 03 1998

MISSOURI  
Public Service Commission

ISSUED:  
July 2, 1998

BY: Richard Lawson  
State Executive, External Affairs  
319 Madison  
Jefferson City, MO 65101

EFFECTIVE:  
August 3, 1998

Cancelled  
April 30, 2007  
Missouri Public  
Service Commission

RECEIVED

ACCESS SERVICE

6. Switched Access Service (Cont'd)

MAR 27 1996

6.1 General (Cont'd)

6.1.1 Feature Group Arrangements and Manner of Provision (Cont'd)  
Public Service Commission

(B) Feature Group B (Cont'd)

FGB Access may also be used to terminate TFC Access service calls. A more detailed description of FGB Access is provided in 6.2.2 following. (T)

(C) Feature Group C (FGC)

FGC Access, which is available only to providers of MTS and WATS, provides trunk side access to Telephone Company end office switches for the customer's use in originating and terminating communications. FGC Access may also be used to originate and terminate TFC Access Service. This service is available in all end offices which are not equipped for Feature Group D End Office Switching. Existing FGC Access will be converted to Feature Group D Access when it becomes available in an end office. The WATS Access Line optional feature set forth in 7.2.11 (A) may be ordered separately by a customer other than the customer which orders the FGC Switched Access Service (i.e., a provider of MTS and WATS). WATS Access Lines are ordered as set forth in 5.2 preceding. A more detailed description of FGC Access is provided in 6.2.3 following. (T)

(D) Feature Group D (FGD)

FGD Access, which is available to all customers, provides trunk side access to Telephone Company end office switches with an associated uniform 10XXX or 101XXXX access code for the customer's use in originating and terminating communications. The WATS Access Line optional feature set forth in 7.2.11 (D) may be ordered separately by a customer other than the customer which orders the FGD Switched Access Service. WATS Access Lines are ordered as set forth in 5.2 preceding. A more detailed description of FGD Access is provided in 6.2.4 following.

CANCELLED

AUG 03 1998  
By 3rd RS # 145  
Public Service Commission  
MISSOURI

FILED

APR 29 1996

MO. PUBLIC SERVICE COMM

ISSUED:  
March 27, 1996

BY: John L. Roe  
Vice President - Carrier and Regulatory Services  
5454 West 110th Street  
Overland Park, Kansas 66211

EFFECTIVE:  
April 29, 1996

UNITED TELEPHONE COMPANY  
OF MISSOURI

First Revised Page 145  
Cancels Original Page 145

RECEIVED

ACCESS SERVICE

JUN 5 1995

6. Switched Access Service (Cont'd)

6.1 General (Cont'd)

6.1.1 Feature Group Arrangements and Manner of Provision (Cont'd)

MO PUBLIC SERVICE COMM.

(B) Feature Group B (Cont'd)

FGB Access may also be used to terminate 800 Access service calls. A more detailed description of FGB Access is provided in 6.2.2 following.

(C) Feature Group C (FGC)

FGC Access, which is available only to providers of MTS and WATS, provides trunk side access to Telephone Company end office switches for the customer's use in originating and terminating communications. FGC Access may also be used to originate and terminate 800 Access Service. This service is available in all end offices which are not equipped for Feature Group D End Office Switching. Existing FGC Access will be converted to Feature Group D Access when it becomes available in an end office. The WATS Access Line optional feature set forth in 7.2.11 (A) may be ordered separately by a customer other than the customer which orders the FGC Switched access Service (i.e., a provider of MTS and WATS). WATS Access Lines are ordered as set forth in 5.2 preceding. A more detailed description of FGC Access is provided in 6.2.3 following.

(D) Feature Group D (FGD)

FGD Access, which is available to all customers, provides trunk side access to Telephone Company end office switches with an associated uniform 10XXX or 101XXXX access code for the customer's use in originating and terminating communications. The WATS Access Line optional feature set forth in 7.2.11 (D) may be ordered separately by a customer other than the customer which orders the FGD Switched Access Service. WATS Access Lines are ordered as set forth in 5.2 preceding. A more detailed description of FGD Access is provided in 6.2.4 following.

(C)  
(C)

CANCELLED

APR 29 1995  
BY *J. R. S.*  
Public Service Commission  
MISSOURI

FILED

JUL 15 1995

MISSOURI  
Public Service Commission

ISSUED:  
June 5, 1995

BY: John L. Roe  
Vice President - Carrier and Regulatory Services  
5454 West 110th Street  
Overland Park, Kansas 66211

EFFECTIVE:  
~~July 5, 1995~~  
JUL 15 1995

UNITED TELEPHONE COMPANY  
OF MISSOURI

Original Page 145

ACCESS SERVICE

RECEIVED

SEP 17 1992

6. Switched Access Service (Cont'd)

6.1 General (Cont'd)

MISSOURI  
Public Service Commission

6.1.1 Feature Group Arrangements and Manner of Provision (Cont'd)

(B) Feature Group B (Cont'd)

FGB Access may also be used to terminate 800 Access service calls. A more detailed description of FGB Access is provided in 6.2.2 following.

(C) Feature Group C (FGC)

FGC Access, which is available only to providers of MTS and WATS, provides trunk side access to Telephone Company end office switches for the customer's use in originating and terminating communications. FGC Access may also be used to originate and terminate 800 Access Service. This service is available in all end offices which are not equipped for Feature Group D End Office Switching. Existing FGC Access will be converted to Feature Group D Access when it becomes available in an end office. The WATS Access Line optional feature set forth in 7.2.11 (A) may be ordered separately by a customer other than the customer which orders the FGC Switched access Service (i.e., a provider of MTS and WATS). WATS Access Lines are ordered as set forth in 5.2 preceding. A more detailed description of FGC Access is provided in 6.2.3 following.

(D) Feature Group D (FGD)

FGD Access, which is available to all customers, provides trunk side access to Telephone Company end office switches with an associated uniform 10XXX access code for the customer's use in originating and terminating communications. The WATS Access Line optional feature set forth in 7.2.11 (D) may be ordered separately by a customer other than the customer which orders the FGD Switched Access Service. WATS Access Lines are ordered as set forth in 5.2 preceding. A more detailed description of FGD Access is provided in 6.2.4 following.

CANCELLED  
JUL 15 1995  
BY *12/RS/145*  
Public Service Commission  
MISSOURI

NOV 7 1992

ISSUED:  
September 17, 1992

BY: John L. Roe  
Vice President - Administration  
5454 West 110th Street  
Overland Park, Kansas 66211

MO. PUBLIC SERVICE COMMISSION

EFFECTIVE:

~~September 17, 1992~~

NOV 7 1992

SPRINT MISSOURI, INC.  
d/b/a SPRINT

Third Revised Page 146  
Cancels Second Revised Page 146

ACCESS SERVICE

Missouri Public

6. Switched Access Service (Cont'd)

REC'D JAN 07 2002

6.1 General (Cont'd)

6.1.1 Feature Group Arrangements and Manner of Provision (Cont'd) <sup>Service Commission</sup>

(E) Manner of Provision

Switched Access is furnished in either quantities of lines or **trunks**. **FGA Access is furnished on a per-line basis and FGB, FGC, FGD Access are furnished on a per trunk basis.**

(C)  
|  
(C)

**Trunks** are differentiated by type and directionality of traffic carried over a Switched Access Service arrangement. Differentiation of traffic is necessary for the Telephone Company to properly design Switched Access Service to meet the traffic carrying capacity requirement of the customer.

There are three major traffic types. These are: Originating, Terminating and Directory Assistance. Originating traffic type represents access capacity **within a LATA for** carrying traffic from the end user to the customer; Terminating traffic type represents access capacity **within a LATA for** carrying traffic from the customer to the end user; and, Directory Assistance traffic type represents access capacity **within a LATA for** carrying Directory Assistance traffic from the customer to a Directory Assistance location. When ordering capacity for FGB Access, FGC Access or FGD Access, the customer must at a minimum specify such access capacity in terms of Originating traffic type and/or Terminating traffic type. Directory Assistance traffic type is used for ordering Directory Assistance Access Service and is provided as set forth in 9. following.

(Z)  
|  
(Z)

Because some customers will wish to further segregate their originating FGC or FGD traffic into separate trunk groups, Originating traffic type is further categorized into Domestic, Interim 500, TFC, 900, and Operator. Domestic traffic type represents access

Missouri Public

FILED FEB 07 2002

Service Commission

ISSUED:  
January 7, 2002

Richard D. Lawson  
State Executive, External Affairs  
319 Madison  
Jefferson City, MO 65101

EFFECTIVE:  
February 7, 2002



RECEIVED

ACCESS SERVICE

6. Switched Access Service (Cont'd)

MAR 27 1996

6.1 General (Cont'd)

6.1.1 Feature Group Arrangements and Manner of Provision  
(Cont'd)

MISSOURI  
Public Service Commission

(E) Manner of Provision

Switched Access is furnished in either quantities of lines or trunks, or in busy hour minutes of capacity (BHMCs). FGA Access and FGB Access are furnished on a per-line or per-trunk basis respectively. FGC Access and FGD Access are furnished on a BHMC basis. FGD may also be provided to customers other than AT&T on a per trunk basis as set forth in 5.2 preceding.

BHMCs and trunks are differentiated by type and directionality of traffic carried over a Switched Access Service arrangement. Differentiation of traffic is necessary for the Telephone Company to properly design Switched Access Service to meet the traffic carrying capacity requirement of the customer.

There are three major traffic types. These are: Originating, Terminating and Directory Assistance. Originating traffic type represents access capacity within an exchange for carrying traffic from the end user to the customer; Terminating traffic type represents access capacity within an exchange for carrying traffic from the customer to the end user; and, Directory Assistance traffic type represents access capacity within an exchange for carrying Directory Assistance traffic from the customer to a Directory Assistance location. When ordering capacity for FGB Access, FGC Access or FGD Access, the customer must at a minimum specify such access capacity in terms of Originating traffic type and/or Terminating traffic type. Directory Assistance traffic type is used for ordering Directory Assistance Access Service and is provided as set forth in 9. following.

Because some customers will wish to further segregate their originating FGC or FGD traffic into separate trunk groups, Originating traffic type is further categorized into Domestic, Interim 500, TFC, 900, and Operator. Domestic traffic type represents access

(T)

CANCELLED

FILED

FEB 07 2002

APR 29 1996

3rd RP 144  
Public Service Commission  
MISSOURI

MISSOURI PUBLIC SERVICE COMMISSION

ISSUED:  
March 27, 1996

BY: John L. Roe  
Vice President - Carrier and Regulatory Services  
5454 West 110th Street  
Overland Park, Kansas 66211

EFFECTIVE:  
April 29, 1996

ACCESS SERVICE

RECEIVED

6. Switched Access Service (Cont'd)

6.1 General (Cont'd)

JAN 11 1995

6.1.1 Feature Group Arrangements and Manner of Provision  
(Cont'd)

(E) Manner of Provision

MO. PUBLIC SERVICE COMM.

Switched Access is furnished in either quantities of lines or trunks, or in busy hour minutes of capacity (BHMCs). FGA Access and FGB Access are furnished on a per-line or per-trunk basis respectively. FGC Access and FGD Access are furnished on a BHMC basis. FGD may also be provided to customers other than AT&T on a per trunk basis as set forth in 5.2 preceding.

BHMCs and trunks are differentiated by type and directionality of traffic carried over a Switched Access Service arrangement. Differentiation of traffic is necessary for the Telephone Company to properly design Switched Access Service to meet the traffic carrying capacity requirement of the customer.

There are three major traffic types. These are: Originating, Terminating and Directory Assistance. Originating traffic type represents access capacity within an exchange for carrying traffic from the end user to the customer; Terminating traffic type represents access capacity within an exchange for carrying traffic from the customer to the end user; and, Directory Assistance traffic type represents access capacity within an exchange for carrying Directory Assistance traffic from the customer to a Directory Assistance location. When ordering capacity for FGB Access, FGC Access or FGD Access, the customer must at a minimum specify such access capacity in terms of Originating traffic type and/or Terminating traffic type. Directory Assistance traffic type is used for ordering Directory Assistance Access Service and is provided as set forth in 9. following.

Because some customers will wish to further segregate their originating FGC or FGD traffic into separate trunk groups, Originating traffic type is further categorized into Domestic, Interim 500, 800, 900, and Operator. Domestic traffic type represents access

(C)

CANCELLED

APR 29 1995  
BY 2nd R.S. #146  
Public Service Commission  
MISSOURI

FILED

FEB 11 1995

MISSOURI  
Public Service Commission

ISSUED:  
January 11, 1995

BY: John L. Roe  
Vice President - Carrier and Regulatory Services  
5454 West 110th Street  
Overland Park, Kansas 66211

EFFECTIVE:  
February 11, 1995

UNITED TELEPHONE COMPANY  
OF MISSOURI

Original Page 146

ACCESS SERVICE

RECEIVED

SEP 17 1992

6. Switched Access Service (Cont'd)

6.1 General (Cont'd)

MISSOURI  
Public Service Commission

6.1.1 Feature Group Arrangements and Manner of Provision  
(Cont'd)

(E) Manner of Provision

Switched Access is furnished in either quantities of lines or trunks, or in busy hour minutes of capacity (BHMCs). FGA Access and FGB Access are furnished on a per-line or per-trunk basis respectively. FGC Access and FGD Access are furnished on a BHMC basis. FGD may also be provided to customers other than AT&T on a per trunk basis as set forth in 5.2 preceding.

BHMCs and trunks are differentiated by type and directionality of traffic carried over a Switched Access Service arrangement. Differentiation of traffic is necessary for the Telephone Company to properly design Switched Access Service to meet the traffic carrying capacity requirement of the customer.

There are three major traffic types. These are: Originating, Terminating and Directory Assistance. Originating traffic type represents access capacity within an exchange for carrying traffic from the end user to the customer; Terminating traffic type represents access capacity within an exchange for carrying traffic from the customer to the end user; and, Directory Assistance traffic type represents access capacity within an exchange for carrying Directory Assistance traffic from the customer to a Directory Assistance location. When ordering capacity for FGB Access, FGC Access or FGD Access, the customer must at a minimum specify such access capacity in terms of Originating traffic type and/or Terminating traffic type. Directory Assistance traffic type is used for ordering Directory Assistance Access Service and is provided as set forth in 9. following.

Because some customers will wish to further segregate their originating FGC or FGD traffic into separate trunk groups, Originating traffic type is further categorized into Domestic, 800, 900, and Operator. Domestic traffic type represents access capacity for carrying only

CANCELLED  
FEB 11 1995  
BY Let R.S. #146  
Public Service Commission  
MISSOURI

NOV 7 1992

MO. PUBLIC SERVICE COMMISSION

ISSUED:  
September 17, 1992

BY: John L. Roe  
Vice President - Administration  
5454 West 110th Street  
Overland Park, Kansas 66211

EFFECTIVE:  
~~September 17, 1992~~  
NOV 7 1992

RECEIVED

ACCESS SERVICE

6. Switched Access Service (Cont'd)

MAR 27 1996

6.1 General (Cont'd)

MISSOURI

6.1.1 Feature Group Arrangements and Manner of Provision (Cont'd)

(E) Manner of Provision (Cont'd)

capacity for carrying only Domestic traffic other than Interim 500, TFC, 900 and Operator traffic; and, represents access capacity for carrying, respectively, only Interim 500, TFC, 900 or Operator traffic. When ordering such types of access capacity, the customer must specify Domestic, Interim 500, TFC, 900 Operator traffic types. (T)

(F) TFC Access Service

TFC Access Service is an originating service that is provided via TFC Access Service switched trunk groups, or may be provided in conjunction with FGB, FGC, or FGD. The service provides for the forwarding of end user dialed TFC calls to a Telephone Company Service Switching Point (SSP) which will initiate a query to the Telephone Company's TFC data base to perform the customer identification function. The call is forwarded to the appropriate customer based on the dialed TFC number. The customer has the option of having the TFC dialed number (i.e., TFC-NXX-XXXX) or, if the TFC to local exchange number translation optional feature is specified, a translated ten digit local exchange number (i.e., NPA-NXX-XXXX) delivered to the customer premises. (T)

When TFC Access Service traffic is combined in the same trunk group arrangement with other traffic, usage for the TFC Access Service traffic will be aggregated with the other traffic for billing purposes. When separate trunk groups are provided for TFC Access Service, usage will be provided separately. A more detailed description of TFC Access Service is as set forth in 6.2.5(B). (T)

(G) 900 Access Service

900 Access Service is an originating service that is provided via 900 Access Service switched trunk groups, or may be provided in conjunction with FGB, FGC, or FGD. The Service provides the customer identification function (900 NXX screening) based on the first six digits of the dialed 900 number. When a 1 + 900 + NXX + XXXX call is originated by an end user, a customer identification function determines the customer to which the call is to be routed based on the NXX dialed. (T)

When a customer requests that the Telephone Company open a 900 NXX access code for exchanges served by the Telephone Company within a specified state, LATA, or exchange area, (T)

APR 29 1996

ISSUED:  
March 27, 1996

BY: John L. Roe  
Vice President - Carrier and Regulatory Services  
5454 West 110th Street  
Overland Park, Kansas 66211

EFFECTIVE:  
April 29, 1996

Cancelled

April 30, 2007  
Missouri Public  
Service Commission

ACCESS SERVICE

6. Switched Access Service (Cont'd)

RECEIVED

6.1 General (Cont'd)

6.1.1 Feature Group Arrangements and Manner of Provision (Cont'd)

FEB 11 1995

(E) Manner of Provision (Cont'd)

capacity for carrying only Domestic traffic other than Interim 500, 800, 900 and Operator traffic; and, Interim 500, 800, 900 and Operator traffic type represents access capacity for carrying, respectively, only Interim 500, 800, 900 or Operator traffic. When ordering such types of access capacity, the customer must specify Domestic, Interim 500, 800, 900 Operator traffic types.

(C)  
(C)  
(C)  
(C)

MO. PUBLIC SERVICE COMM.

(F) 800 Access Service

800 Access Service is an originating service that is provided via 800 Access Service switched trunk groups, or may be provided in conjunction with FGB, FGC, or FGD. The service provides for the forwarding of end user dialed 800 calls to a Telephone Company Service Switching Point (SSP) which will initiate a query to the Telephone Company's 800 data base to perform the customer identification function. The call is forwarded to the appropriate customer based on the dialed 800 number. The customer has the option of having the 800 dialed number (i.e., 800-NXX-XXXX) or, if the 800 to local exchange number translation optional feature is specified, a translated ten digit local exchange number (i.e., NPA-NXX-XXXX) delivered to the customer premises.

When 800 Access Service traffic is combined in the same trunk group arrangement with other traffic usage for the 800 Access Service traffic will be aggregated with the other traffic for billing purposes. When separate trunk groups are provided for 800 Access Service, usage will be provided separately. A more detailed description of 800 Access Service is set forth in 6.2.5(B).

CANCELLED  
APR 13 1995  
BY 3rd R.S. #147  
Public Service Commission  
MISSOURI

(G) 900 Access Service

900 Access Service is an originating service provided via 900 Access Service switched trunk groups, or may be provided in conjunction with FGB, FGC, or FGD. The Service provides the customer identification function (900 NXX screening) based on the first six digits of the dialed 900 number. When a 1 + 900 + NXX + XXXX call is originated by an end user, a customer identification function determines the customer to which the call is to be routed based on the NXX dialed.

When a customer requests that the Telephone Company open a 900 NXX access code for exchanges served by the Telephone Company within a specified state, LATA or

(N)  
(N)

FEB 11 1995

ISSUED:  
January 11, 1995

BY: John L. Roe  
Vice President - Carrier and Regulatory Services  
5454 West 110th Street  
Overland Park, Kansas 66211

MISSOURI PUBLIC SERVICE COMMISSION  
EFFECTIVE:  
February 11, 1995



ACCESS SERVICE

6. Switched Access Service (Cont'd)

6.1 General (Cont'd)

6.1.1 Feature Group Arrangements and Manner of Provision (Cont'd)

(E) Manner of Provision (Cont'd)

Domestic traffic other than 800, 900 and Operator traffic; and, 800, 900 and Operator traffic type represents access capacity for carrying, respectively, only 800, 900 or Operator traffic. When ordering such types of access capacity, the customer must specify Domestic, 800, 900 Operator traffic types.

(F) 800 Access Service

800 Access Service is an originating service that is provided via 800 Access Service switched trunk groups, or may be provided in conjunction with FGB, FGC, or FGD. The service provides for the forwarding of end user dialed 800 calls to a Telephone Company Service Switching Point (SSP) which will initiate a query to the Telephone Company's 800 data base to perform the customer identification function. The call is forwarded to the appropriate customer based on the dialed 800 number. The customer has the option of having the 800 dialed number (i.e., 800-NXX-XXXX) or, if the 800 to local exchange number translation optional feature is specified, a translated ten digit local exchange number (NPA-NXX-XXXX) delivered to the customer premises.

When 800 Access Service traffic is combined in the same trunk group arrangement with other traffic, usage for the 800 Access Service traffic will be aggregated with the other traffic for billing purposes. When separate trunk groups are provided for 800 Access Service, usage will be provided separately. A more detailed description of 800 Access Service is as set forth in 6.2.5.

6.1.2 WATS Access Line Service

WATS Access Line Service is a type of Special Access Service that is provided only for use with Feature Group C and D Switched Access Service. WATS Access Line Service connects end user premises with a WATS or WATS-type Service Office. This Service is described in 7.2.11 following.

RECEIVED  
MAR 31 1993

MO. PUBLIC SERVICE COMM.

CANCELLED

FEB 11 1995

BY: RS # 147  
Public Service Commission  
MISSOURI

(N)

(N)

MAY 01 1993

MO. PUBLIC SERVICE COMM.

ISSUED:  
March 31, 1993

BY: John L. Roe  
Vice President - Administration  
5454 West 110th Street  
Overland Park, Kansas 66211

EFFECTIVE:  
May 1, 1993

UNITED TELEPHONE COMPANY  
OF MISSOURI

Original Page 147

RECEIVED

ACCESS SERVICE

SEP 17 1992

6. Switched Access Service (Cont'd)

MISSOURI  
Public Service Commission

6.1 General (Cont'd)

6.1.1 Feature Group Arrangements and Manner of Provision (Cont'd)

(E) Manner of Provision (Cont'd)

Domestic traffic other than 800, 900 and Operator traffic; and, 800, 900 and Operator traffic type represents access capacity for carrying, respectively, only 800, 900 or Operator traffic. When ordering such types of access capacity, the customer must specify Domestic, 800, 900 Operator traffic types.

6.1.2 WATS Access Line Service

WATS Access Line Service is a type of Special Access Service that is provided only for use with Feature Group C and D Switched Access Service. WATS Access Line Service connects end user premises with a WATS or WATS-type Service Office. This Service is described in 7.2.11 following.

6.1.3 Rate Categories

There are three rate categories which apply to Switched Access Service:

- Local Transport (described in 6.1.3(B) following)
- End Office (described in 6.1.3(C) following)
- Common Line (described in Section 3, and 4, preceding)

In addition to these three rate categories, there is an Information Surcharge that applies to all Switched Access Feature Groups. The description and application of this charge are set forth in 6.7.15 following.

CANCELLED

MAY 1 1993  
BY 1st R.S. #147  
Public Service Commission  
MISSOURI

FILED

NOV 7 1992

MO. PUBLIC SERVICE COMMISSION

ISSUED:  
September 17, 1992

BY: John L. Roe  
Vice President - Administration  
5454 West 110th Street  
Overland Park, Kansas 66211

EFFECTIVE:  
~~October 1, 1992~~  
NOV 7 1992

ACCESS SERVICE

RECEIVED

6. Switched Access Service (Cont'd)

6.1 General (Cont'd)

JAN 11 1995

6.1.1 Feature Group Arrangements and Manner of Provision (Cont'd)

(G) 900 Access Service (Cont'd)

MO. PUBLIC SERVICE COMMISSION

service area subtending an access tandem, the order must include the provisioning of all Telephone Company offices within that state, LATA or all offices subtending the specified access tandem.

When 900 Access Service is combined in the same trunk group arrangement with other traffic, usage for the 900 Access Service traffic will be aggregated with the other traffic for billing purposes. When separate trunk groups are provided for 900 Access Service, usage will be provided separately. A more detailed description of 900 Access Service is as set forth in 6.2.5(D).

(H) Interim 500 Access Service

Interim 500 Access Service is an originating service that is provided via Interim 500 Access Service switched trunk groups, or may be provided in conjunction with FGC, or FGD. The Service provides the customer identification function (500 NXX screening) based on the first six digits of the dialed 500 number. When a 1 + 500 + NXX + XXXX call is originated by an end user, a customer identification function determines the customer to which the call is to be routed based on the NXX dialed.

When a customer requests that the Telephone Company open a 500 NXX access code for exchanges served by the Telephone Company within a specified state, LATA or service area subtending an access tandem, the order must include the provisioning of all Telephone Company offices within that state, LATA or all offices subtending the specified access tandem.

When Interim 500 Access Service traffic is combined in the same trunk group arrangement with other traffic, usage for the Interim 500 Access Service traffic will be aggregated with the other traffic for billing purposes. When separate trunk groups are provided for Interim 500 Access Service, usage will be provided separately. A more detailed description of Interim 500 Access Service is as set forth in 6.2.5(C).

6.1.2 WATS Access Line Service

WATS Access Line Service is a type of Special Access Service that is provided only for use with Feature Group C and D of Switched Access Service. WATS Access Line Service connects end user premises with a WATS or WATS-type Service Office. This Service is described in 7.2.11 following.

(M)  
|  
(M)

FEB 11 1995

ISSUED:  
January 11, 1995

BY: John L. Roe  
Vice President - Carrier and Regulatory Services  
5454 West 110th Street  
Overland Park, Kansas 66211

MISSOURI  
Public Service Commission  
EFFECTIVE  
February 11, 1995

ACCESS SERVICE

6. Switched Access Service (Cont'd)

6.1 General (Cont'd)

6.1.3 Rate Categories

There are three rate categories which apply to Switched Access Service:

- Local Transport (described in 6.1.3(B) following)
- Local Switching (described in 6.1.3(C) following)
- Common Line (described in Section 3, and 4, preceding)

In addition to these three rate categories, there are also charges which apply only to Interim 500, TFC and 900 Access Service. The description and application of TFC Access Service charges are set forth in 6.1.3(D). The description and application of 900 Access Service charges are set forth in 6.1.3(E), 6.7.1(C)(4), and 6.7.16 following. The description and application of Interim 500 Access Service charges are set forth in 6.1.3(F), 6.7.1(C)(5), and 6.7.16 following.

The following diagram depicts a generic view of the components of Switched Access Service and the manner in which the components are combined to provide a complete access service.

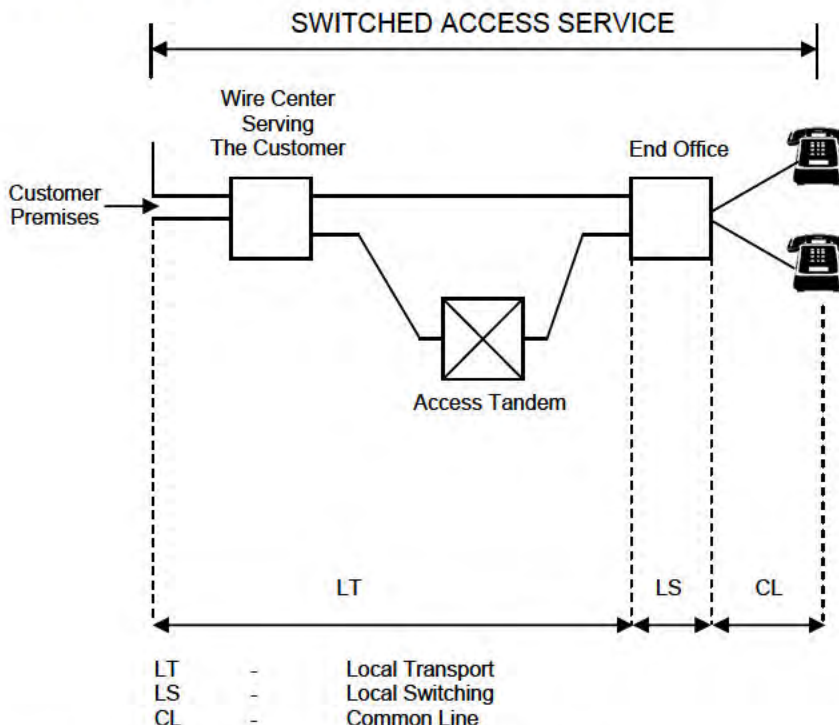

\*Common line access is provided under Section 3. preceding.

ISSUED:  
March 30, 2007  
CANCELED  
July 1, 2012  
Missouri Public  
Service Commission  
TT-2012-0317, YI-2012-0635

Mark D. Harper  
Director - State Regulatory  
5454 W. 110th Street  
Overland Park, Kansas 66211

EFFECTIVE:  
April 30, 2007



SPRINT MISSOURI, INC.  
d/b/a SPRINT

Fifth Revised Page 148  
Cancels Fourth Revised Page 148

ACCESS SERVICE

Missouri Public

REC'D JAN 07 2002

Service Commission

6. Switched Access Service (Cont'd)

6.1 General (Cont'd)

6.1.3 Rate Categories

There are three rate categories which apply to Switched Access Service:

- Local Transport (described in 6.1.3(B) following)
- Local Switching (described in 6.1.3(C) following)
- Common Line (described in Section 3, and 4, preceding)

In addition to these three rate **categories**, **there** are also charges which apply only to Interim 500, TFC and 900 Access Service. The description and application of TFC Access Service charges are set forth in 6.1.3(D). The description and application of 900 Access Service charges are set forth in 6.1.3(E), 6.7.1(C)(4), and 6.7.16 following. The description and application of Interim 500 Access Service charges are set forth in 6.1.3(F), 6.7.1(C)(5), and 6.7.16 following.

(T)

The following diagram depicts a generic view of the components of Switched Access Service and the manner in which the components are combined to provide a complete access service.

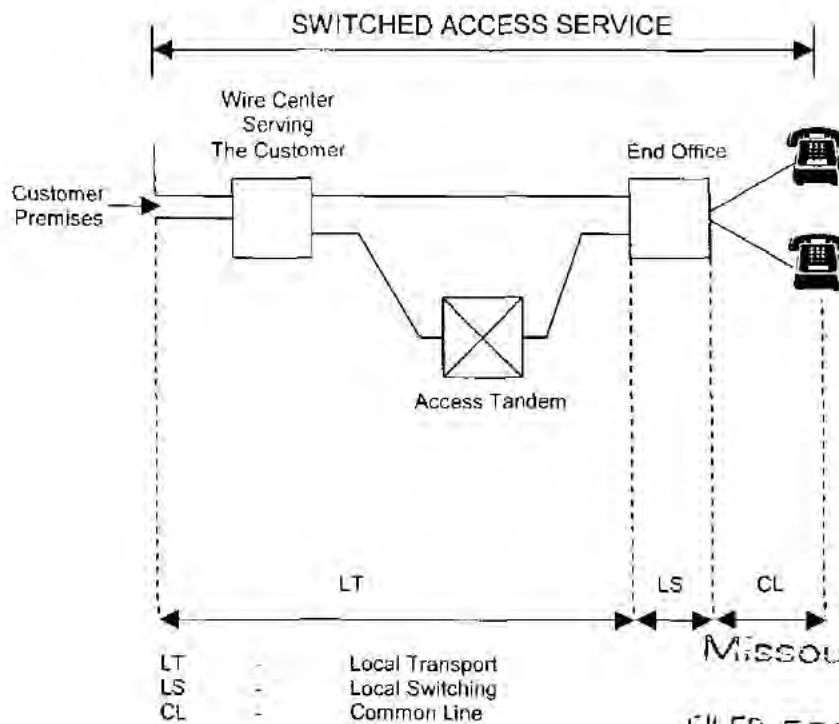

Missouri Public

FILED FEB 07 2002

Service Commission

\*Common line access is provided under Section 3. preceding.

ISSUED:  
January 7, 2002

Richard D. Lawson  
State Executive, External Affairs  
319 Madison  
Jefferson City, MO 65101

EFFECTIVE:  
February 7, 2002



RECEIVED

ACCESS SERVICE

6. Switched Access Service (Cont'd)

MAR 27 1996

6.1 General (Cont'd)

MISSOURI  
Public Service Commission

6.1.3 Rate Categories

There are three rate categories which apply to Switched Access Service:

- Local Transport (described in 6.1.3(B) following)
- Local Switching (described in 6.1.3(C) following)
- Common Line (described in Section 3, and 4, preceding)

In addition to these three rate categories, there is an Information Surcharge that applies to all Switched Access Service Arrangements. The description and application of this charge is set forth in 6.7.15 following. There are also charges which apply only to Interim 500, TFC and 900 Access Service. The description and application of TFC Access Service charges are set forth in 6.1.3(D). The description and application of 900 Access Service charges are set forth in 6.1.3(E), 6.7.1(C)(4), and 6.7.16 following. The description and application of Interim 500 Access Service charges are set forth in 6.1.3(F), 6.7.1(C)(5), and 6.7.16 following.

(T)  
(T)

The following diagram depicts a generic view of the components of Switched Access Service and the manner in which the components are combined to provide a complete access service.

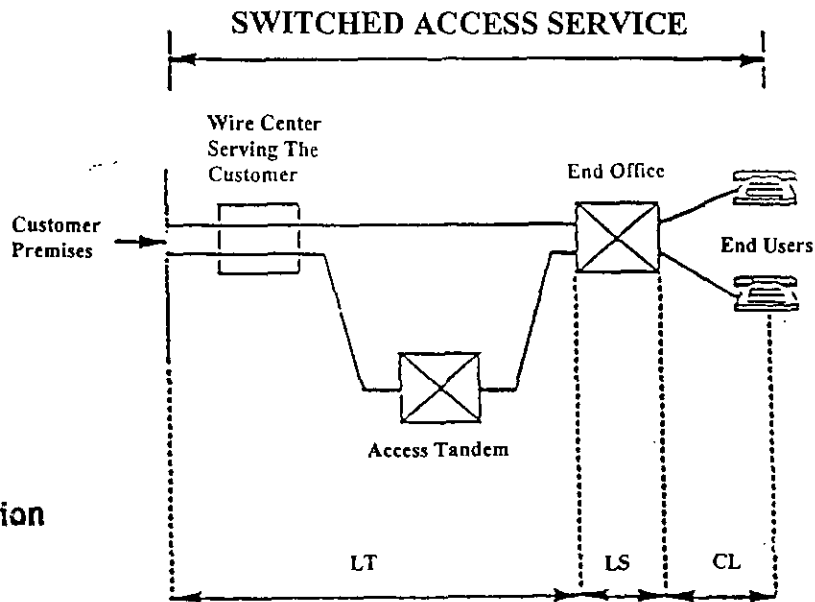

CANCELLED

FEB 07 2002

1 5th RP 148  
Public Service Commission  
MISSOURI

FILED

MAR 29 1996

LT - Local Transport  
LS - Local Switching  
CL - Common Line

\*Common line access is provided under Section 3. preceding.

ISSUED:  
March 27, 1996

BY: John L. Roe  
Vice President - Carrier and Regulatory Services  
5454 West 110th Street  
Overland Park, Kansas 66211

EFFECTIVE:  
April 29, 1996

RECEIVED

ACCESS SERVICE

6. Switched Access Service (Cont'd)

JAN 11 1995

6.1 General (Cont'd)

6.1.3 Rate Categories

MO. PUBLIC SERVICE COMM. (Z)

There are three rate categories which apply to Switched Access Service:

- Local Transport (described in 6.1.3(B) following)
- Local Switching (described in 6.1.3(C) following)
- Common Line (described in Section 3, and 4, preceding)

In addition to these three rate categories, there is an Information Surcharge that applies to all Switched Access Service Arrangements. The description and application of this charge is set forth in 6.7.15 following. There are also charges which apply only to Interim 500, 800 and 900 Access Service. The description and application of 800 Access Service charges are set forth in 6.1.3(D). The description and application of 900 Access Service charges are set forth in 6.1.3(E), 6.7.1(C)(4), and 6.7.16 following. The description and application of Interim 500 Access Service charges are set forth in 6.1.3(F), 6.7.1(C)(5), and 6.7.16 following.

The following diagram depicts a generic view of the components of Switched Access Service and the manner in which the components are combined to provide a complete access service.

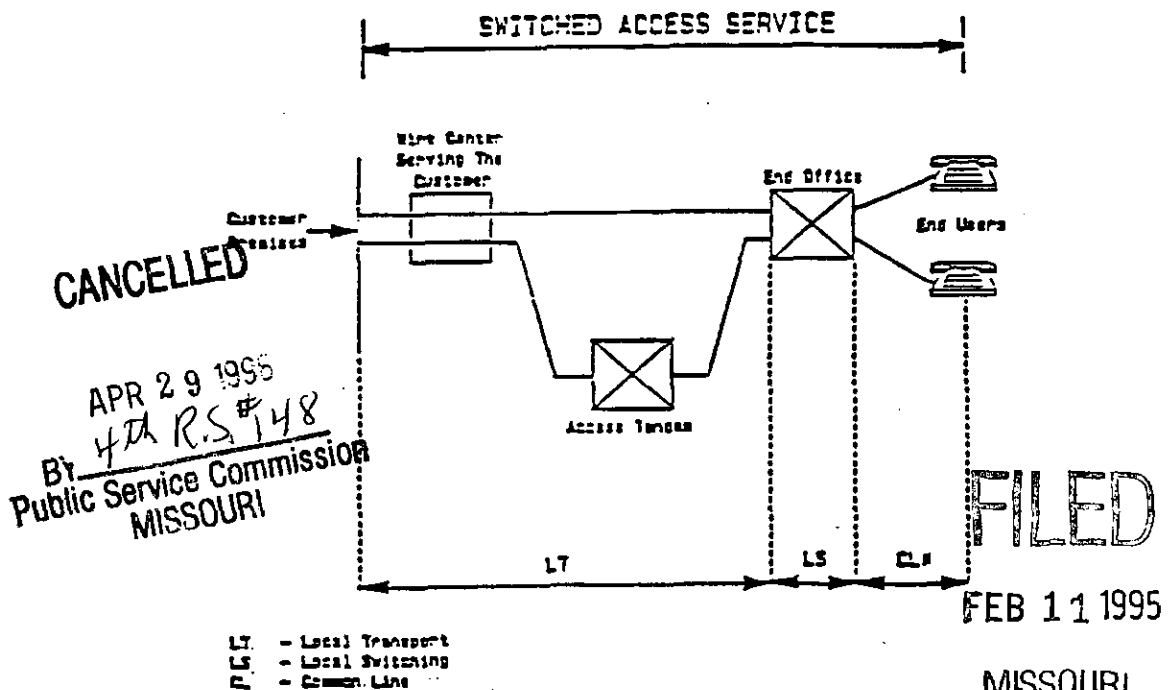

LT - Local Transport  
 LS - Local Switching  
 CL - Common Line

\*Common line access is provided under Section 3. preceding.

MISSOURI  
 Public Service Commission

ISSUED:  
 January 11, 1995

BY: John L. Roe  
 Vice President - Carrier and Regulatory Services  
 5454 West 110th Street  
 Overland Park, Kansas 66211

EFFECTIVE:  
 February 11, 1995

~~FILED~~

ACCESS SERVICE

NOV 2 1993

6. Switched Access Service (Cont'd)

6.1 General (Cont'd)

MO. PUBLIC SERVICE JOURNAL

6.1.3 Rate Categories (Cont'd)

There are three rate categories which apply to Switched Access Service:

- Local Transport (described in 6.1.3(B) following)
- Local Switching (described in 6.1.3(C) following)
- Common Line (described in Section 3, and 4, preceding)

In addition to these three rate categories, there is an Information Surcharge that applies to all Switched Access Feature Groups. The description and application of this charge are set forth in 6.7.15 following.

The following diagram depicts a generic view of the components of Switched Access Service and the manner in which the components are combined to provide a complete access service.

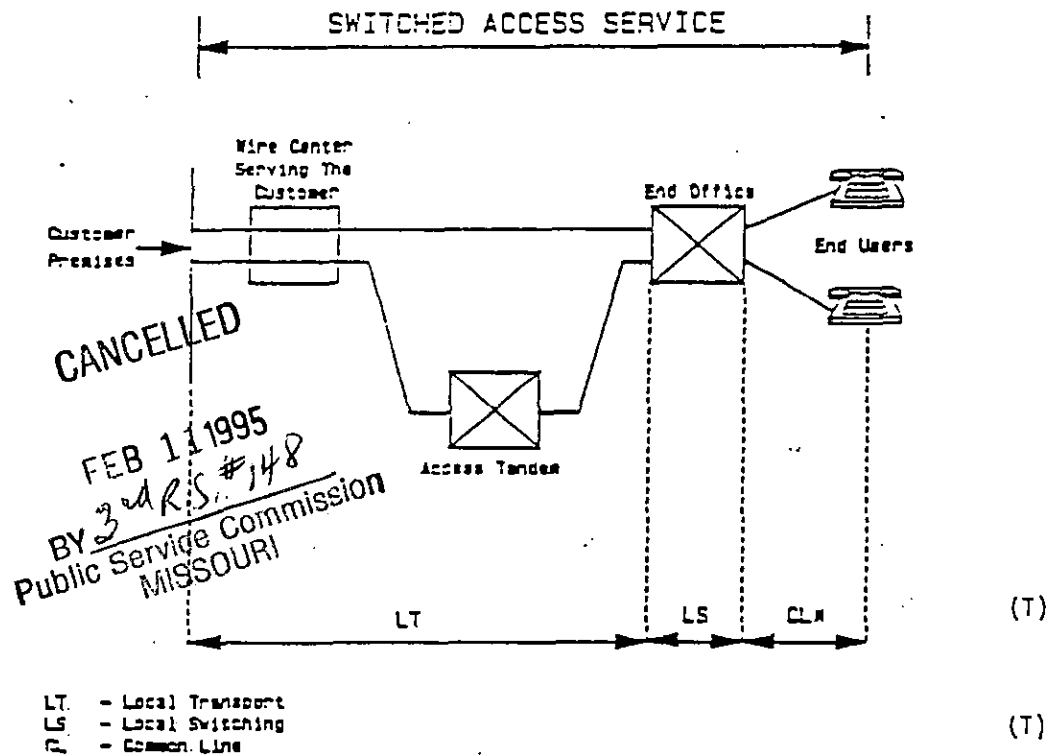

\*Common line access is provided under Section 3. preceding.

ISSUED:  
November 3, 1993

BY: John L. Roe  
Vice President-Administration  
5454 West 110th Street  
Overland Park, Kansas 66211

FILED

EFFECTIVE:  
November 7, 1993

NOV 7 1993  
93-181  
MO. PUBLIC SERVICE COMM.

ACCESS SERVICE

RECEIVED

MAR 31 1993

MO. PUBLIC SERVICE COMMISSION

6. Switched Access Service (Cont'd)

6.1 General (Cont'd)

6.1.3 Rate Categories (Cont'd)

There are three rate categories which apply to Switched Access Service:

- Local Transport (described in 6.1.3(B) following)
- Local Switching (described in 6.1.3(C) following)
- Common Line (described in Section 3, and 4, preceding)

In addition to these three rate categories, there is an Information Surcharge that applies to all Switched Access Feature Groups. The description and application of this charge are set forth in 6.7.15 following.

The following diagram depicts a generic view of the components of Switched Access Service and the manner in which the components are combined to provide a complete access service.

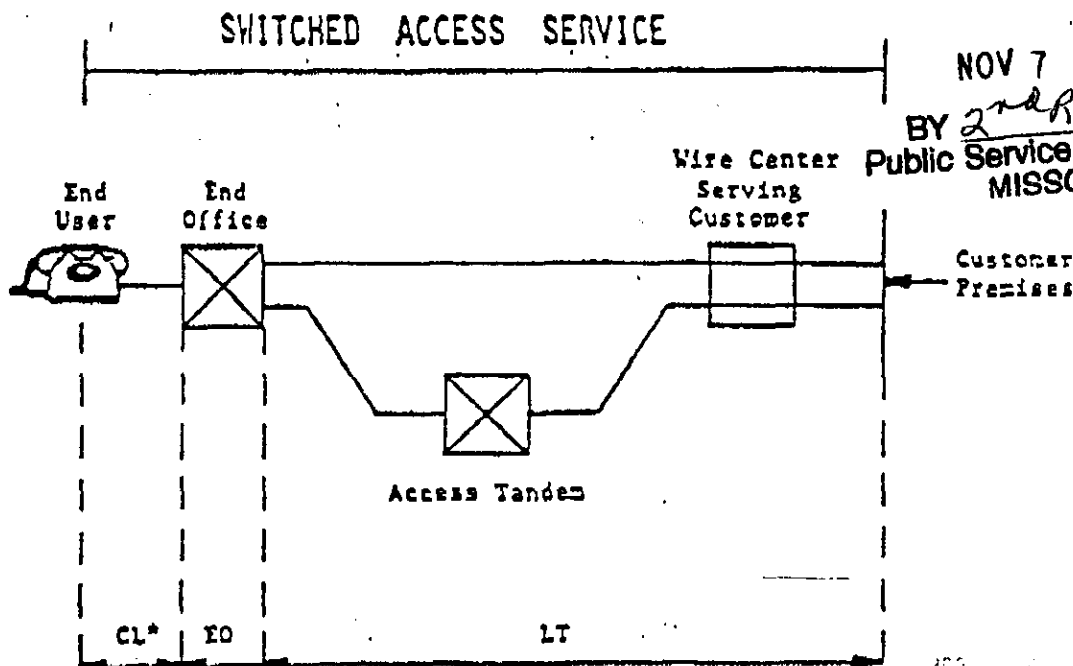

LT -Local Transport  
 EO -End Office  
 CL -Common Line

CANCELLED

NOV 7 1993  
BY 2nd P. S. #148  
Public Service Commission  
MISSOURI

MAY 0 1 1993

\*Common line access is provided under Section 3. preceding.

ISSUED:  
March 31, 1993

BY: John L. Roe  
Vice President - Administration  
5454 West 110th Street  
Overland Park, Kansas 66211

EFFECTIVE:  
May 1, 1993

UNITED TELEPHONE COMPANY  
OF MISSOURI

Original Page 148

ACCESS SERVICE

RECEIVED

SEP 17 1992

6. Switched Access Service (Cont'd)

MISSOURI  
Public Service Commission

6.1 General (Cont'd)

6.1.3 Rate Categories (Cont'd)

The following diagram depicts a generic view of the components of Switched Access Service and the manner in which the components are combined to provide a complete access service.

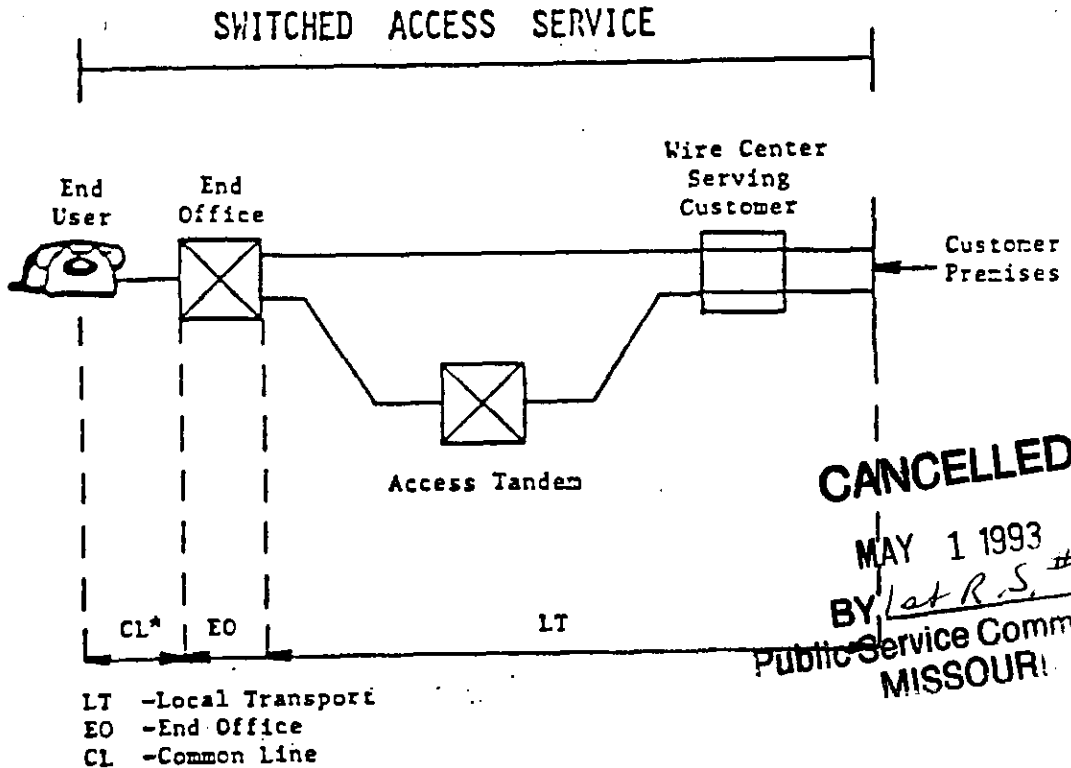

**CANCELLED**  
MAY 1 1993  
BY *Lat R.S. #148*  
Public Service Commission  
MISSOURI

\*Common line access is provided under Section 3. preceding.

ISSUED:  
September 17, 1992

BY: John L. Roe  
Vice President - Administration  
5454 West 110th Street  
Overland Park, Kansas 66211

NOV 7 1992  
EFFECTIVE:  
~~October 17, 1992~~  
NOV 7 1992