

ACCESS SERVICE
RATES AND CHARGES

8. Rates and Charges (Cont'd)

8.2 Switched Access Service

8.2.3 Switched Transport - Tandem Switched Transport

(A) Tandem-Switched Transmission

Tandem-Switched Transmission is included in the Local Switching Indirect Connect and Toll Free 8YY Transit Traffic Service rate.

(B) Switched Transport - Tandem Switching

Tandem-Switching is included in the Toll Free 8YY Transit Traffic Service rates.

(C) Common Transport Multiplexing

Common Transport Multiplexing is included in the Local Switching Indirect Connect and Toll Free 8YY Transit Traffic Service rates.

(D) Common Trunk Port

The Common Trunk Port is included in the Local Switching rate element.

(E) Dedicated Trunk Port

DS1

The DS1 Dedicated Trunk Port is not provided on an Individual Case Basis when an IXC is not co-located with the Sprint switch and will not exceed the competing ILEC rate for the same function. This element will be charged only in rare instances when an IXC directly connects with Sprint and is not co-located.

(M)

(T) (M)

(C)

(T)

(C)

(C) (M)

(T) (M1)

(C)

(T)

(T)

(C)

(M1)

(C)

(M) Material now appearing on this page previously appeared on Original Page 8-2.

(M1) Material now appearing on this page previously appeared on Original Page 8-3.

Issue Date:
October 15, 2009

Margaret R. Prendergast
Manager, Tariffs
6450 Sprint Parkway
Overland Park, KS 66251

Effective Date:
November 14, 2009

ACCESS SERVICE
RATES AND CHARGES

8. Rates and Charges (Cont'd)

8.2 Switched Access Service (Cont'd)

(M)

(M)

8.2.4 Switched Transport - Optional Features

Multiplexing

DS3 to DS1

DS3 to DS1 Multiplexing is provided on an Individual Case Basis when an IXC is not co-located with the Sprint switch and will not exceed the competing ILEC rate for the same function. This element will be charged only in rare instances when an IXC directly connects with Sprint and is not co-located..

(C)

(C)

(M1)

(M1)

(M) Material previously appearing on this page now appears on Original Page 8-2.1.

(M1) Material previously appearing on this page now appears on Original Page 8-3.1.

Issue Date:
October 15, 2009

Margaret R. Prendergast
Manager, Tariffs
6450 Sprint Parkway
Overland Park, KS 66251

Effective Date:
November 14, 2009

CANCELLED
June 16, 2021
Missouri Public
Service Commission
TD-2021-0319

Filed
Missouri Public
Service Commission
JX-2010-0280

ACCESS SERVICE
RATES AND CHARGES

8. Rates and Charges (Cont'd)

8.2 Switched Access Service (Cont'd)

8.2.3 Switched Transport - Tandem Switched Transport (Cont'd)

(D) Common Transport Multiplexing

Common Transport Multiplexing is included in the Local Switching rate element.

(E) Common Trunk Port

The Common Trunk Port is included in the Local Switching rate element.

(F) Dedicated Trunk Port

DS1

The DS1 Dedicated Trunk Port is included In the Local Switching rate element.

8.2.4 Switched Transport - Optional Features

Multiplexing

DS3 to DS1

DS3 to DS1 Multiplexing is included in the Local Switching rate element.

8.2.5 Local Switching

Rate
Per Access Minute

Local Switching is a composite rate.

\$0.023336

8.2.6 Installation

Nonrecurring
Charges

Per Line or Trunk

\$52.00

8.2.7 Carrier Common Line Access Service

Carrier Common Line is included in the Local Switching Rate Element.

Issue Date:
July 15, 2003

CANCELLED
November 14, 2009
Missouri Public
Service Commission
JX-2010-0280

Warren D. Hannah
Director, Tariffs
6450 Sprint Parkway
Overland Park, KS 66251

Effective Date:
August 16, 2003

FILED
Missouri Public
Service Commission

ACCESS SERVICE
 RATES AND CHARGES

8. Rates and Charges (Cont'd)

8.1 Switched Access Service (Cont'd)

8.2.5 Local Switching

Local Switching is a composite rate.

	<u>Direct Connect Rate Per Access Minute</u>	<u>Indirect Connect Rate Per Access Minute</u>	
Originating:			(T)
Southwestern Bell	\$0.0034630	\$0.0035930	
Embarq	\$0.0044810	\$0.0051610	
CenturyLink	\$0.0058208	\$0.0065506	
All other ILEC areas	\$0.0034630	\$0.0035930	
Terminating:			(T)
Southwestern Bell	\$0.0034630	\$0.0035930	
Embarq	\$0.0044810	\$0.0051610	
CenturyLink	\$0.0058208	\$0.0065506	
All other ILEC areas	\$0.0034630	\$0.0035930	

8.2.6 Installation

Nonrecurring
Charges

Per Line or Trunk \$52.00

8.2.7 Carrier Common Line Access Service

Carrier Common Line is included in the Local Switching Rate Element.

* Local Switching Direct Connect is comprised of the following rate elements: Carrier Common Line (CCL) and End Office Charge which includes Local Switching and Common Trunk Port. (T)

** Local Switching Indirect Connect is comprised of the following rate elements: Carrier Common Line (CCL); End Office Charge which includes Local Switching and Common Trunk Port; Tandem Switched Transmission, which includes Tandem Transport Termination (fixed) and Tandem Transport Mileage (10 miles); and Common Transport Multiplexing. (T)

ACCESS SERVICE
 RATES AND CHARGES

8. Rates and Charges (Cont'd)

8.1 Switched Access Service (Cont'd)

8.2.5 Local Switching

Local Switching is a composite rate.

	<u>Direct Connect Rate Per Access Minute</u>	<u>Indirect Connect Rate Per Access Minute</u>	
Southwestern Bell Telephone Company	\$0.0034630	\$0.0035930	(R) (T)
Embarq Local Operating Companies	\$0.0044810	\$0.0051610	(R)
CenturyLink Operating Companies	\$0.0058208	\$0.0065506	(R)
All other ILEC areas	\$0.0034630	\$0.0035930	(R)(T)

8.2.6 Installation

Nonrecurring
Charges

Per Line or Trunk \$52.00

8.2.7 Carrier Common Line Access Service

Carrier Common Line is included in the Local Switching Rate Element.

* Local Switching Direct Connect is comprised of the following rate elements: Common Carrier Line (CCL) and End Office Charge which includes Local Switching and Common Trunk Port.

** Local Switching Indirect Connect is comprised of the following rate elements: Common Carrier Line (CCL); End Office Charge which includes Local Switching and Common Trunk Port; Tandem Switched Transmission, which includes Tandem Transport Termination (fixed) and Tandem Transport Mileage (10 miles); and Common Transport Multiplexing.

Issue Date:
 February 29, 2012

Margaret R. Prendergast
 Manager, Tariffs
 6450 Sprint Parkway
 Overland Park, KS 66251

Effective Date:
 March 2, 2012

Filed
 Missouri Public
 Service Commission
 JX-2012-0408

CANCELLED
 October 25, 2012
 Missouri Public
 Service Commission
 JC-2013-0148

ACCESS SERVICE
 RATES AND CHARGES

8. Rates and Charges (Cont'd)

8.2 Switched Access Service (Cont'd)

8.2.2 Local Switching

Local Switching is a composite rate.

	<u>Direct Connect Rate</u> <u>Per Access Minute</u>	<u>Indirect Connect Rate</u> <u>Per Access Minute</u>	
Originating	\$0.016607	\$0.024088	(R)
Terminating	\$0.023415	\$0.030896	(R)

8.2.6 Installation

Nonrecurring
Charges

Per Line or Trunk \$52.00

8.2.7 Carrier Common Line Access Service

Carrier Common Line is included in the Local Switching Rate Element.

* Local Switching Direct Connect is comprised of the following rate elements: Common Carrier Line (CCL) and End Office Charge which includes Local Switching and Common Trunk Port.

** Local Switching Indirect Connect is comprised of the following rate elements: Common Carrier Line (CCL); End Office Charge which includes Local Switching and Common Trunk Port; Tandem Switched Transmission, which includes Tandem Transport Termination (fixed) and Tandem Transport Mileage (10 miles); and Common Transport Multiplexing.

Issue Date:
 February 28, 2011

Margaret R. Prendergast
 Manager, Tariffs
 6450 Sprint Parkway
 Overland Park, KS 66251

Effective Date:
 March 2, 2011

CANCELLED
 March 2, 2012
 Missouri Public
 Service Commission
 JX-2012-0408

Filed
 Missouri Public
 Service Commission
 JX-2011-0437

ACCESS SERVICE
 RATES AND CHARGES

8. Rates and Charges (Cont'd)

8.2 Switched Access Service (Cont'd)

8.2.2 Local Switching

Local Switching is a composite rate.

	<u>Direct Connect Rate</u> <u>Per Access Minute</u>	<u>Indirect Connect Rate</u> <u>Per Access Minute</u>	
Originating	\$0.017919	\$0.025400	(C)(I)
Terminating	\$0.025805	\$0.033286	(C)(I)

8.2.6 Installation

Nonrecurring
Charges

Per Line or Trunk \$52.00

8.2.7 Carrier Common Line Access Service

Carrier Common Line is included in the Local Switching Rate Element.

* Local Switching Direct Connect is comprised of the following rate elements: Common Carrier Line (CCL) and End Office Charge which includes Local Switching and Common Trunk Port.

** Local Switching Indirect Connect is comprised of the following rate elements: Common Carrier Line (CCL); End Office Charge which includes Local Switching and Common Trunk Port; Tandem Switched Transmission, which includes Tandem Transport Termination (fixed) and Tandem Transport Mileage (10 miles); and Common Transport Multiplexing.

Issue Date:
 December 3, 2009
CANCELLED
 March 2, 2011
 Missouri Public
 Service Commission
 JX-2011-0437

Margaret R. Prendergast
 Manager, Tariffs
 6450 Sprint Parkway
 Overland Park, KS 66251

Effective Date:
 January 2, 2010

FILED
 Missouri Public
 Service Commission
 JX-2010-0373

ACCESS SERVICE
RATES AND CHARGES

8. Rates and Charges (Cont'd)

8.2 Switched Access Service (Cont'd)

8.2.8 Local Switching

(M)

Local Switching is a composite rate.

Direct Connect Rate* (C)	Indirect Connect Rate ** (C)
<u>Per Access Minute</u> (C)	<u>Per Access Minute</u>
\$0.015855 (R)	\$0.023336

8.2.6 Installation

Nonrecurring
Charges

Per Line or Trunk \$52.00

8.2.7 Carrier Common Line Access Service

Carrier Common Line is included in the Local Switching Rate Element.

(M)

* Local Switching Direct Connect is comprised of the following rate elements: Common Carrier Line (CCL) and End Office Charge which includes Local Switching and Common Trunk Port. (N)

** Local Switching Indirect Connect is comprised of the following rate elements: Common Carrier Line (CCL); End Office Charge which includes Local Switching and Common Trunk Port; Tandem Switched Transmission, which includes Tandem Transport Termination (fixed) and Tandem Transport Mileage (10 miles); and Common Transport Multiplexing. (N)

(M) Material now appearing on this page previously appeared on Original Page 8-3.

ACCESS SERVICE
 RATES AND CHARGES

8. Rates and Charges (Cont'd)

8.2 Switched Access Service (Cont'd)

8.2.8 Toll Free 8YY Transit Traffic Service

	<u>Direct Connect#</u> <u>Per Access Minute</u>	<u>Indirect Connect ##</u> <u>Per Access Minute</u>	(T)
Originating	\$0.003330	\$0.00660	
Terminating	\$0.0003410	\$0.0004180	(R)(T)

Toll Free 8YY Transit Traffic -Direct Connect is comprised of the following rate elements: Tandem Switched Transmission, which includes one-half Tandem Transport Termination (fixed) and Tandem Transport Mileage (1 mile); Tandem Switching; and one-half Common Transport Multiplexing.

Toll Free 8YY Transit Traffic -Indirect Connect is comprised of Tandem Switched Transmission, which includes Tandem Transport Termination (fixed) and Tandem Transport Mileage (10 miles); Tandem Switching; and Common Transport Multiplexing. These rates also apply in the event of an overflow situation with Toll Free 8YY Transit Traffic Service Direct Connect.

Issue Date:
 May 2, 2012

Margaret R. Prendergast
 Manager, Tariffs
 6450 Sprint Parkway
 Overland Park, KS 66251

Effective Date:
 July 1, 2012

CANCELLED
 June 16, 2021
 Missouri Public
 Service Commission
 TD-2021-0319

Filed
 Missouri Public
 Service Commission
 TT-2012-0317; JX-2012-0669

ACCESS SERVICE
 RATES AND CHARGES

8. Rates and Charges (Cont'd)

8.2 Switched Access Service (Cont'd)

8.2.8 Toll Free 8YY Transit Traffic Service

Direct Connect #
Per Access Minute

Indirect Connect ##
Per Access Minute

\$0.003330

\$0.006660

(R)

Toll Free 8YY Transit Traffic -Direct Connect is comprised of the following rate elements: Tandem Switched Transmission, which includes one-half Tandem Transport Termination (fixed) and Tandem Transport Mileage (1 mile); Tandem Switching; and one-half Common Transport Multiplexing.

Toll Free 8YY Transit Traffic -Indirect Connect is comprised of Tandem Switched Transmission, which includes Tandem Transport Termination (fixed) and Tandem Transport Mileage (10 miles); Tandem Switching; and Common Transport Multiplexing. These rates also apply in the event of an overflow situation with Toll Free 8YY Transit Traffic Service Direct Connect.

Issue Date:
 February 29, 2012

Margaret R. Prendergast
 Manager, Tariffs
 6450 Sprint Parkway
 Overland Park, KS 66251

Effective Date:
 March 2, 2012

CANCELLED
 July 1, 2012

Missouri Public
 Service Commission

Filed
 Missouri Public
 Service Commission
 JX-2012-0408

ACCESS SERVICE
RATES AND CHARGES

8. Rates and Charges (Cont'd)

8.2 Switched Access Service (Cont'd)

8.2.8 Toll Free 8YY Transit Traffic Service

Direct Connect #
Per Access Minute

\$0.003741

Indirect Connect ##
Per Access Minute

\$0.007481

(N)
|
(N)

Toll Free 8YY Transit Traffic -Direct Connect is comprised of the following rate elements: Tandem Switched Transmission, which includes one-half Tandem Transport Termination (fixed) and Tandem Transport Mileage (1 mile); Tandem Switching; and one-half Common Transport Multiplexing.

(N)
|
(N)

Toll Free 8YY Transit Traffic -Indirect Connect is comprised of Tandem Switched Transmission, which includes Tandem Transport Termination (fixed) and Tandem Transport Mileage (10 miles); Tandem Switching; and Common Transport Multiplexing. These rates also apply in the event of an overflow situation with Toll Free 8YY Transit Traffic Service Direct Connect.

Issue Date:
October 15, 2009

Margaret R. Prendergast
Manager, Tariffs
6450 Sprint Parkway
Overland Park, KS 66251

Effective Date:
November 14, 2009

CANCELLED
March 2, 2012
Missouri Public
Service Commission
JX-2012-0408

Filed
Missouri Public
Service Commission
JX-2010-0280

ACCESS SERVICE
 RATES AND CHARGES

8. Rates and Charges (Cont'd)

8.3 Toll Free Database Access Service (TFDBAS)

8.3.1 TFDBAS Database Query

(A) Customer Identification Function TFDBQ Basic Query Charge*

	<u>Rate</u>			
- Per Query	\$0.00500			(R)

(B) TFDBAS – Vertical Feature Query Charge**

	<u>Rate</u>			
- Per Query	\$0.001365			

8.4 900 Access Service

Nonrecurring
 Charges

8.4.1 Assembly of Route Pattern

	\$23.80			
- Per end office switch (including end offices collocated with access tandem)				

8.4.2 900 NXX Code Activation or Deactivation

	\$7.70			
- Per NXX Code added or deleted per end office				

8.5 Additional Labor and Miscellaneous Services

8.5.1 Additional Labor Rates

	<u>First Half Hour or Fraction Thereof</u>	<u>Each Add'l Half Hour or Fraction Thereof</u>
<u>Additional Labor Periods</u>		
(A) Basic Time, normally scheduled working hours, per engineer or technician	\$40.00	\$30.00
(B) Overtime, outside of normally scheduled working hours, per engineer or technician	\$45.00	\$35.00
(C) Premium time, outside of scheduled work day, per engineer or technician	\$50.00	\$40.00

* This charge applies to all Toll Free Calls – both attempted and successfully delivered calls to the customer.

** Toll Free calls that have vertical features will incur a TFDBQ Vertical Query Charge in addition to the TFDBQ Basic Query Charge. When a combination of one or more Toll Free vertical features is defined for a given Toll Free call, only one TFDBQ Vertical Feature Query Charge will apply.

Issue Date: Margaret R. Prendergast
 October 15, 2009 Manager, Tariffs
 6450 Sprint Parkway
 Overland Park, KS 66251

Effective Date:
 November 14, 2009

ACCESS SERVICE
 RATES AND CHARGES

8. Rates and Charges (Cont'd)

8.3 Toll Free Database Access Service (TFDBAS) (T)

8.3.1 TFDBAS Database Query (T)

(A) Customer Identification Function TFDBQ Basic Query Charge* (T)

-	Per Query	<u>Rate</u> \$.01623
---	-----------	-------------------------

(B) TFDBAS – Vertical Feature Query Charge** (N)

-	Per Query	<u>Rate</u> \$0.001365	(N)
---	-----------	---------------------------	-----

8.4 900 Access Service

Nonrecurring
 Charges

8.4.1 Assembly of Route Pattern

-	Per end office switch (including end offices collocated with access tandem)	\$23.80
---	---	---------

8.4.2 900 NXX Code Activation or Deactivation

-	Per NXX Code added or deleted per end office	\$7.70
---	--	--------

8.5 Additional Labor and Miscellaneous Services

8.5.1 Additional Labor Rates

<u>Additional Labor Periods</u>	<u>First Half Hour or Fraction Thereof</u>	<u>Each Add'l Half Hour or Fraction Thereof</u>
(A) Basic Time, normally scheduled working hours, per engineer or technician	\$40.00	\$30.00
(B) Overtime, outside of normally scheduled working hours, per engineer or technician	\$45.00	\$35.00
(C) Premium time, outside of scheduled work day, per engineer or technician	\$50.00	\$40.00

* This charge applies to all Toll Free Calls – both attempted and successfully delivered calls to the customer. (N)

** Toll Free calls that have vertical features will incur a TFDBQ Vertical Query Charge in addition to the TFDBQ Basic Query Charge. When a combination of one or more Toll Free vertical features is defined for a given Toll Free call, only one TFDBQ Vertical Feature Query Charge will apply. (N)

Issue Date:
 August 15, 2008

Margaret R. Prendergast
 Manager, Tariffs
 6450 Sprint Parkway
 Overland Park, KS 66251

Effective Date:
 September 15, 2008

CANCELLED
 November 14, 2009
 Missouri Public
 Service Commission
 JX-2010-0280

FILED
 Missouri Public
 Service Commission

ACCESS SERVICE
 RATES AND CHARGES

8. Rates and Charges (Cont'd)

8.3 Toll Free Code (TFC) Access Service

8.3.1 TFC Access Service Data Base Query
 - Per Query

Rate

\$0.01623

(Z)

8.4 900 Access Service

Nonrecurring
 Charges

8.4.1 Assembly of Route Pattern

- Per end office switch (including end
 offices collocated with access tandem)

\$23.80

8.4.2 900 NXX Code Activation or Deactivation

- Per NXX Code added or deleted per end office

\$7.70

8.5 Additional Labor and Miscellaneous Services

8.5.1 Additional Labor Rates

First Half
 Hour
 or Fraction
 Thereof

Each Add'l
 Half Hour
 or Fraction
 Thereof

Additional Labor Periods

(A) Basic Time, normally scheduled
 working hours, per engineer or
 technician

\$40.00

\$30.00

(B) Overtime, outside of normally
 scheduled working hours, per
 engineer or technician

\$45.00

\$35.00

(C) Premium time, outside of
 scheduled work day, per
 engineer or technician

\$50.00

\$40.00

Issue Date:
 July 24, 2007

Margaret R. Prendergast
 Manager – State Tariffs
 6450 Sprint Parkway
 Overland Park, KS 66251

Effective Date:
 August 23, 2007

ACCESS SERVICE
RATES AND CHARGES

8. Rates and Charges (Cont'd)

8.3 Toll Free Code (TFC) Access Service

Rate

8.3.1 TFC Access Service Data Base Query

- Per Query

\$.001623

8.4 900 Access Service

Nonrecurring
Charges

8.4.1 Assembly of Route Pattern

- Per end office switch (including end offices collocated with access tandem)

\$23.80

8.4.2 900 NXX Code Activation or Deactivation

- Per NXX Code added or deleted per end office

\$7.70

8.5 Additional Labor and Miscellaneous Services

8.5.1 Additional Labor Rates

First Half
Hour
or Fraction
Thereof

Each Add'l
Half Hour
or Fraction
Thereof

Additional Labor Periods

(A) Basic Time, normally scheduled working hours, per engineer or technician

\$40.00

\$30.00

(B) Overtime, outside of normally scheduled working hours, per engineer or technician

\$45.00

\$35.00

(C) Premium time, outside of scheduled work day, per engineer or technician

\$50.00

\$40.00

Issue Date:
July 15, 2003

Warren D. Hannah
Director, Tariffs
6450 Sprint Parkway
Overland Park, KS 66251

Effective Date:
August 16, 2003

ACCESS SERVICE
RATES AND CHARGES

8. Rates and Charges (Cont'd)8.5 Additional Labor and Miscellaneous Services (Cont'd)8.5.2 Additional Testing ServicesRate(A) Additional Automatic Testing

(1004 Hz loss, C-Message Noise,
Balance, Gain Slope and C-Notched Noise)

The Additional Automatic Tests, as set forth following,
may be ordered by the customer, at additional charges,
60 days prior to the start of the customer's prescribed
schedule.

Per Test, Per Transmission Path \$1.70

Per Report Provided \$20.00

(B) Additional Cooperative Testing

(1004 Hz loss, C-Message Noise,
Balance, Gain Slope and C-Notched Noise)

The Additional Cooperative Tests, as set forth following,
may be ordered by the customer, at additional charges,
60 days prior to the start of the testing schedule as
mutually agreed to by the customer and the Company.

Per Test, Per Transmission Path \$4.80

Issue Date:
July 15, 2003

CANCELLED
June 16, 2021
Missouri Public
Service Commission
TD-2021-0319

Warren D. Hannah
Director, Tariffs
6450 Sprint Parkway
Overland Park, KS 66251

Effective Date:
August 16, 2003

FILED
Missouri Public
Service Commission

ACCESS SERVICE
 RATES AND CHARGES

8. Rates and Charges (Cont'd)

8.5 Additional Labor and Miscellaneous Services (Cont'd)

8.5.3 Provision of Access Service Billing Information

	<u>Monthly Rate</u>	<u>Nonrecurring Charge</u>
(A) <u>Additional copies of the customer's monthly bill or service and features records</u>		
- Per copy, per account in standard paper format	\$12.30	\$14.90
(B) <u>Additional copies of the customer's monthly monthly bill or service and features records</u>		
- Per CD-ROM	\$85.00	\$91.88

8.5.4 Telecommunications Service Priority (TSP) System

	<u>Monthly Rate</u>	<u>Nonrecurring Charge</u>
- Per Circuit	\$0.00	\$0.00

8.5.5 Billing Name and Address (BNA)

- Per BNA Request	\$0.25	(N)
-------------------	--------	-----

8.6 Operator Services

8.6.1 Operator Inward Assistance (OIA) Service

<u>Busy Line Verification</u>	<u>Busy Line Interrupt</u>
\$1.50	\$2.75

Issue Date:
 November 1, 2007

Margaret R. Prendergast
 Senior Manager - Tariffs
 6450 Sprint Parkway
 Overland Park, KS 66251

Effective Date:
 December 1, 2007

ACCESS SERVICE
RATES AND CHARGES

8. Rates and Charges (Cont'd)

8.5 Additional Labor and Miscellaneous Services (Cont'd)

8.5.3 Provision of Access Service Billing Information

	<u>Monthly Rate</u>	<u>Nonrecurring Charge</u>
(A) <u>Additional copies of the customer's monthly bill or service and features records</u>		
- Per copy, per account in standard paper format	\$12.30	\$14.90
(B) <u>Additional copies of the customer's monthly monthly bill or service and features records</u>		
- Per CD-ROM	\$85.00	\$91.88

8.5.4 Telecommunications Service Priority (TSP) System

	<u>Monthly Rate</u>	<u>Nonrecurring Charge</u>
- Per Circuit	\$0.00	\$0.00

8.6 Operator Services

8.6.1 Operator Inward Assistance (OIA) Service

<u>Busy Line Verification</u>	<u>Busy Line Interrupt</u>
\$1.50	\$2.75

Issue Date:
July 15, 2003

Warren D. Hannah
Director, Tariffs
6450 Sprint Parkway
Overland Park, KS 66251

Effective Date:
August 16, 2003

ACCESS SERVICE

9. Operator Services9.1 Operator Services Description

Operator Services includes the service category of Operator Inward Assistance. Operator Inward Assistance service is provided from OSS Tandems to the customer's premises in conjunction with the rules and regulations of the specified Access Services found in Sections 2, 3, 5, and 6 preceding. Operator Services are available at all Company end offices, however may be unavailable in certain LATAs due to existing trunking arrangements. In locations where the provider of operator services is not the Company, availability of operator services is at the discretion of the operator services provider. If operator services are available, the Company rates are applicable and billed by the Company. In locations where the Company is the provider of operator services for other telephone companies, availability of operator services is contingent on the availability of operator services tariffs of that telephone company. The OSS Tandem locations are provided in National Exchange Carrier Association, Inc. Tariff F.C.C. No. 4.

9.1.1 Operator Inward Assistance (OIA) Service

Operator Inward Assistance provides operator service functions on inward calls received from customers. Operator Inward Assistance is provided when a customer's operator contacts a Company operator requesting line status verification or verification with call interruption. Inward Assistance functions will be performed for only one telephone number per inward call received. The Inward Assistance service functions available are detailed as follows:

- (A) **Busy Line Verification** - The operator will check the status of the requested telephone line to verify if there is conversation on the line and advise the requesting customer of the line status.
- (B) **Verification with Call Interruption** - After verification of a conversation on the requested line is made, and upon request, the operator will interrupt and inform the called party of the waiting call. The operator only interrupts the ongoing call and does not complete the subsequent telephone call for the customer.

Issue Date:
July 15, 2003

CANCELLED
June 16, 2021
Missouri Public
Service Commission
TD-2021-0319

Warren D. Hannah
Director, Tariffs
6450 Sprint Parkway
Overland Park, KS 66251

Effective Date:
August 16, 2003

FILED
Missouri Public
Service Commission

ACCESS SERVICE

9. Operator Services (Cont'd)9.2 Manner of Provisioning

Operator Services trunking between the customer's premises and the OSS Tandem is provisioned as Feature Group D service and may be arranged, per the customer's request, as either 1-way or 2-way service. These trunk groups are established as final trunks and will be assigned data registers to obtain usage, peg count, and overflow attempt information. If a trunk(s) does not currently exist between the customer's premises and the OSS Tandem(s), the customer must establish Feature Group D service to the Company's OSS Tandem(s). The Company will provide trunk side switching along with trunk answer and disconnect supervisory signaling to the customer.

9.2.1 Signaling

For Operator Inward Assistance, the Company will provide Equal Access signaling for Feature Group D service.

9.2.2 Ordering and Billing Options and Conditions

- (A) An access order is not required to receive Operator Inward Assistance services.
- (B) Billing for all Operator Services will occur on a monthly basis as other billing is performed, but will be rendered on a statement detailing the flat-rated charges for the entire state applicable to that customer for the specified monthly period.

Issue Date:
July 15, 2003

CANCELLED
June 16, 2021
Missouri Public
Service Commission
TD-2021-0319

Warren D. Hannah
Director, Tariffs
6450 Sprint Parkway
Overland Park, KS 66251

Effective Date:
August 16, 2003

FILED
Missouri Public
Service Commission

ACCESS SERVICE

9. Operator Services (Cont'd)9.3 Liability of the Telephone Company

In addition to the liability statements as set forth in Section 2 preceding, the following also applies.

- (A) The Company's liability, if any, for its gross negligence or willful misconduct is not limited by this price list. With respect to any other claim or suit, by a customer or any others, for damages arising out of negligent mistakes, omissions, interruptions, delays or errors, defects in transmission, omission from or defects in the applicable list of customers or transfers to customers occurring in the course of furnishing service hereunder, the Company's liability, if any, shall not exceed an amount equivalent to the proportionate charge to the customer for the period of time during which such mistake, omission, interruptions, delays, errors, defects in transmission or service, omissions from or defects in the applicable list of customers or transfers to customers continues. However, any such mistakes, omissions, interruptions, delays, errors, or defects in transmission or service, omissions from or defects in the applicable list of customers or transfers to customers which are caused by or contributed to by the negligent omission or willful act of the customer provided facilities or equipment shall not result in the imposition of any liability whatsoever upon the Company. The Company expressly disclaims any express or implied warranty for the aforesaid service or offering including no warranty of merchantability or warranty of fitness for any particular purpose. It is expressly acknowledged by all subscribers to the aforesaid service that errors, mistakes and omissions can and will occur and that the Company neither warrants nor guarantees faultless or perfect service or transmission.
- (B) The customer indemnifies and saves the Company harmless against claims for libel, slander, or infringement of copyright and trademark arising from the information transmitted over facilities furnished hereunder and against all other claims arising out of any act or omission of the customer in connection with facilities provided by the Company.
- (C) The customer indemnifies and saves the Company harmless against claims or suits for damages arising where the connection between the calling end user and a local emergency agency is in some way faulty or impaired, due in whole or in part to the negligent mistake or delay of the Company. Examples of this may include, but are not limited to, instances in which the Company, through negligent mistake or delay, may provide an incorrect local emergency agency number, delay in locating a local emergency agency number, or disconnect an in-progress call between a calling end user and a local emergency agency.

Issue Date:
July 15, 2003

CANCELLED
June 16, 2021
Missouri Public
Service Commission
TD-2021-0319

Warren D. Hannah
Director, Tariffs
6450 Sprint Parkway
Overland Park, KS 66251

Effective Date:
August 16, 2003

FILED
Missouri Public
Service Commission

ACCESS SERVICE

9. Operator Services (Cont'd)

9.4 Obligations of the Customer

In addition to the general regulations as set forth in Section 2 preceding, the following also applies.

- (A) The customer shall provide the necessary on-hook, off-hook, answer supervision, and disconnect supervision at the customer's premises.
- (B) Jurisdictional reporting will apply as required in Section 2.3.9 for determining the Percent Interstate Usage (PIU).

9.5 Rate Regulations

9.5.1 Description and Application of Rates and Charges

The Operator Inward Assistance flat-rated charges are specific to the operator function performed and are applied per attempt to the requesting customer. The charges include all operator work time and equipment necessary to perform the requested operator function. The specific charges for Inward Assistance are shown below:

- (1) Busy Line Verification - applicable per busy line verify attempt.
- (2) Verification with Call Interrupt - applicable per busy line verify/call interrupt attempt.

Switched Access rates, including CCL charges and nonrecurring charges are not applicable for Operator Inward Assistance services.

9.5.2 Rates and Charges

Rates are included in Section 8.

Issue Date:
July 15, 2003

CANCELLED
June 16, 2021
Missouri Public
Service Commission
TD-2021-0319

Warren D. Hannah
Director, Tariffs
6450 Sprint Parkway
Overland Park, KS 66251

Effective Date:
August 16, 2003

FILED
Missouri Public
Service Commission

ACCESS SERVICE

- 10. Reserved for Future Use

Issue Date:
July 15, 2003

CANCELLED
June 16, 2021
Missouri Public
Service Commission
TD-2021-0319

Warren D. Hannah
Director, Tariffs
6450 Sprint Parkway
Overland Park, KS 66251

Effective Date:
August 16, 2003

FILED
Missouri Public
Service Commission

ACCESS SERVICE

11. Reserved for Future Use

Issue Date:
July 15, 2003

CANCELLED
June 16, 2021
Missouri Public
Service Commission
TD-2021-0319

Warren D. Hannah
Director, Tariffs
6450 Sprint Parkway
Overland Park, KS 66251

Effective Date:
August 16, 2003

FILED
Missouri Public
Service Commission

ACCESS SERVICE

12. Specialized Services or Arrangements

Rates for special pricing arrangements will be developed on a case-by-case basis in response to a bona fide request from a customer or prospective customer to develop a competitive bid for service(s) offered under this Tariff. Rates quoted in response to competitive requests may be different than those specified for such in this Tariff. Special pricing will be offered to the Customer in writing on a non-discriminatory basis and will be filed with the Missouri Public Service Commission.

Rates for ICB arrangements will be developed on a case-by-case basis in response to a bona fide request from a customer or prospective customer for services not offered under this tariff. ICB rates will be offered to the Customer in writing and on a non-discriminatory basis and will be filed with the Missouri Public Service Commission.

Issue Date:
July 15, 2003

CANCELLED
June 16, 2021
Missouri Public
Service Commission
TD-2021-0319

Warren D. Hannah
Director, Tariffs
6450 Sprint Parkway
Overland Park, KS 66251

Effective Date:
August 16, 2003

FILED
Missouri Public
Service Commission

ACCESS SERVICE

13. Additional Labor and Miscellaneous Services

In this Section, Basic Time refers to the period when services are performed by the Company on business days during regularly scheduled work hours. Overtime refers to the period when services are performed by the Company on business days but outside of regularly scheduled work hours. Premium time refers to the period when services are performed by the Company on non-business days, such as weekends and holidays.

13.1 Additional Labor

Additional labor is that labor requested by the customer on a given service and agreed to by the Company as set forth in 13.1.1 through 13.1.7 following. The Company will notify the customer that additional labor charges as set forth in 13.1.8 following will apply before any additional labor is undertaken. Rates are included in section 8.

13.1.1 Engineering

Additional Engineering will be provided by the Company at the request of the customer only when:

- (A) A customer requests additional technical information after the Company has already provided the technical information normally included on the Design Layout Report (DLR). The Company will notify the customer that additional labor charges will apply before any additional engineering is undertaken.

13.1.2 Overtime Installation

Overtime installation is that Company installation effort outside of normally scheduled working hours.

13.1.3 Overtime Repair

Overtime repair is that Company maintenance effort performed outside of normally scheduled working hours.

Issue Date:
July 15, 2003

CANCELLED
June 16, 2021
Missouri Public
Service Commission
TD-2021-0319

Warren D. Hannah
Director, Tariffs
6450 Sprint Parkway
Overland Park, KS 66251

Effective Date:
August 16, 2003

FILED
Missouri Public
Service Commission

ACCESS SERVICE

13. Additional Labor and Miscellaneous Services (Cont'd)

13.1 Additional Labor (Cont'd)

13.1.4 Stand By

Stand by includes all time in excess of one-half (1/2) hour during which Company personnel stand by to make cooperative tests with a customer to verify facility repair on a given service.

13.1.5 Testing and Maintenance with Other Telephone Companies

Testing and Maintenance with Other Telephone Companies is that additional testing, maintenance or repair of facilities which connect to facilities of other telephone companies, which is in addition to normal effort required to test, maintain or repair facilities provided solely by the Company.

13.1.6 Additional Installation Testing

Additional installation testing is that testing performed by the Company at the time of installation which is in addition to the normal preservice acceptance testing to ensure the satisfactory performance of Access Service ordered by the Customer. In no event shall a charge be made for Additional Labor that is related solely to testing with other telephone companies.

13.1.7 Other Labor

Other labor is that additional labor not included in 13.1.1 through 13.1.6 preceding and labor incurred to accommodate a specific customer request that involves only labor which is not covered by any other section of this tariff.

13.1.8 Charges for Additional Labor

Hourly charges are calculated from the time Company personnel are dispatched to when the work is completed.

Service by a Company employee at a time not consecutive with his scheduled work period is subject to a minimum charge of 3 hours at the rate specified in section 8.

Issue Date:
July 15, 2003

CANCELLED
June 16, 2021
Missouri Public
Service Commission
TD-2021-0319

Warren D. Hannah
Director, Tariffs
6450 Sprint Parkway
Overland Park, KS 66251

Effective Date:
August 16, 2003

FILED
Missouri Public
Service Commission

ACCESS SERVICE

13. Additional Labor and Miscellaneous Services (Cont'd)

13.1 Additional Labor (Cont'd)

13.1.9 Maintenance of Service

- (A) When a customer reports a trouble to the Company for clearance and no trouble is found in the Company's facilities, the customer shall be responsible for payment of a Maintenance of Service charge for the period of time from when Company personnel are dispatched to when the work is completed. Failure of Company personnel to find trouble in Company facilities will result in no charge if the trouble is actually in those facilities, but not discovered at the time.
- (B) The customer shall be responsible for payment of a Maintenance of Service charge when the Company dispatches personnel and the trouble is in equipment or communications systems provided by other than the Company or in detariffed CPE provided by the Company.

Maintenance of Service charges are applied on a per half hour, per technician basis. Rates are included in section 8.

Issue Date:
July 15, 2003

CANCELLED
June 16, 2021
Missouri Public
Service Commission
TD-2021-0319

Warren D. Hannah
Director, Tariffs
6450 Sprint Parkway
Overland Park, KS 66251

Effective Date:
August 16, 2003

FILED
Missouri Public
Service Commission

ACCESS SERVICE

13. Additional Labor and Miscellaneous Services (Cont'd)

13.1 Additional Labor (Cont'd)

13.1.10 Testing Services

Testing Services such as Additional Automatic Testing and Additional Cooperative Testing are optional and subject to additional rates and charges. Other testing services provided by the Company in association with Access Services are furnished at no additional charge.

Testing services are normally provided by Company personnel at Company locations. However, provisions are made for a customer to request Company personnel to perform testing services at the customer's premises.

The offering of Testing Services under this section of the tariff is made subject to the availability of the necessary qualified personnel and test equipment at the test location. In order to facilitate scheduling of the Company's test equipment and personnel, the customer should request any desired Additional Tests with 60 days advance notice. Whenever feasible, the Company will accommodate requests with less than 60 days advance notice.

Testing is available where technically feasible.

Rates for testing services are located in section 8.

Issue Date:
July 15, 2003

CANCELLED
June 16, 2021
Missouri Public
Service Commission
TD-2021-0319

Warren D. Hannah
Director, Tariffs
6450 Sprint Parkway
Overland Park, KS 66251

Effective Date:
August 16, 2003

FILED
Missouri Public
Service Commission

ACCESS SERVICE

13. Additional Labor and Miscellaneous Services (Cont'd)13.2 Miscellaneous Services13.2.1 Provision of Access Service Billing Information

- (A) The customer shall select the medium in which its official access service bills and customer service records are to be provided. This selection shall be made on a per account basis and shall be submitted in writing to the Company. The customer may request that access service billing information be provided via electronic data transfer, standard paper format or CD-ROM. Should the customer fail to make a selection, the official copy of the customer's access service bills and customer service records will be provided in standard paper format.
- (B) At the customer's option, additional copies of the current month's access service bill and/or customer service records will be provided via standard paper format or CD-ROM at the charges specified in section 8. Requests for additional copies of the current month's bill and/or customer service records must be submitted in writing and shall specify the medium selected by the customer (i.e., standard paper format or CD-ROM).
- Additional copies of a customer's previous monthly access service bills will be provided via standard paper format or CD-ROM on an individual case basis. Requests for additional copies of previous monthly bills must be submitted in writing and shall specify the bill dates requested and the medium in which the copies are to be provided (i.e., standard paper or CD-ROM). The charges for providing additional copies of previous monthly access service bills will be developed by the Company on an individual case basis.
- (C) Upon acceptance by the Company of an order for electronic data transfer, the Company will determine the period of time to implement the transmission of such material on an individual order basis.
- (D) The rates and charges for the provision of Access Service Billing Information are included in section 8.

Issue Date:
July 15, 2003

CANCELLED
June 16, 2021
Missouri Public
Service Commission
TD-2021-0319

Warren D. Hannah
Director, Tariffs
6450 Sprint Parkway
Overland Park, KS 66251

Effective Date:
August 16, 2003

FILED
Missouri Public
Service Commission

ACCESS SERVICE

13. Additional Labor and Miscellaneous Services (Cont'd)13.2 Miscellaneous Services (Cont'd)13.2.2 Telecommunications Service Priority (TSP) System1. Description

The TSP System is a service that provides for the priority provisioning and/or restoration of National Security Emergency Preparedness (NSEP) telecommunications services. The TSP system applies only to NSEP services, which includes Switched Access facilities and local exchange and intrastate services and provides the Company with a guide to the sequence in which services are to be provisioned and/or restored.

All facilities that can be identified by a unique circuit identifier can be provisioned for TSP service by the Company.

The Executive Office of the President is empowered with the authority to receive, evaluate and process requests for NSEP TSP Services. The Executive Office of the President, through the TSP Program office as its administrative branch, makes the priority level assignments and issues the TSP authorization code reflecting the priority assignments associated with the Customer's request. The Customer initiates the request for TSP service from the TSP Program office through an agency of the federal government. The Customer then provides the TSP authorization code, in addition to all other details necessary to complete the order, and submits it to the Company for appropriate action.

Issue Date:
July 15, 2003

Warren D. Hannah
Director, Tariffs
6450 Sprint Parkway
Overland Park, KS 66251

Effective Date:
August 16, 2003

CANCELLED
June 16, 2021
Missouri Public
Service Commission
TD-2021-0319

FILED
Missouri Public
Service Commission

ACCESS SERVICE

13. Additional Labor and Miscellaneous Services (Cont'd)13.2 Miscellaneous Services (Cont'd)13.2.3 Billing Name and Address (BNA)(A) Service Description

Billing Name and Address (BNA) service provides account detail of the Company's customers to interexchange carriers, operator service providers, enhanced service providers, and any other provider of intrastate telecommunications services.

(B) General

- (1) Upon acceptance of an order for BNA service, the Company will furnish account detail for each working telephone number submitted. Account detail consists of current data base information including the end user's billing name and billing address.
- (2) Only current information which resides in the Company's data base will be provided. Customers ordering BNA service must accept BNA account detail on an "as is" basis.
- (3) The Company will specify the location where requests for BNA service are to be received, and the format in which the requests are to be provided.
- (4) The subscribing customer must agree that BNA information will not be resold or otherwise provided to any other person, corporation, partnership or entity, other than Customer's authorized billing agent, and that Billing Name and Address shall be used by Customer or Customer's authorized billing agent solely for:
 - (a) Billing its customers for using Customer's telecommunications services,
 - (b) Any purpose associated with the equal access requirement of United States v. AT&T, 552 F.Supp. 131 (D.D.C. 1982),
 - (c) Verification of service orders of new customers, identification of customers who have moved to a new address, fraud prevention, and similar non-marketing purposes.

Issue Date:
November 1, 2007

Margaret R. Prendergast
Senior Manager - Tariffs
6450 Sprint Parkway
Overland Park, KS 66251

Effective Date:
December 1, 2007

ACCESS SERVICE

13. Additional Labor and Miscellaneous Services (Cont'd)

13.2 Miscellaneous Services (Cont'd)

13.2.3 Billing Name and Address (BNA) (Cont'd)

(B) General (Cont'd)

(5) BNA Requests

- (a) The Company will provide BNA, subject to procedures established for Customer Account Record Exchange (CARE).
- (b) The customer will submit their requests through proper CARE procedures, as revised or amended.
- (c) The Company will provide a copy of the proper CARE procedures for BNA, as revised or amended, to each customer upon request.

(C) Rate Regulations

The number of BNA records for which charges apply will be accumulated by the Company, and billed to the customer on a monthly basis. An Access Order charge as set forth in Section 8 will also apply.

(D) Rates and Charges

Rates and charges are included in Section 8.

Issue Date:
November 1, 2007

Margaret R. Prendergast
Senior Manager - Tariffs
6450 Sprint Parkway
Overland Park, KS 66251

Effective Date:
December 1, 2007

ACCESS SERVICE
RATES AND CHARGES

14. Call Flow Diagrams

14.1 Transit Access – Direct Routing

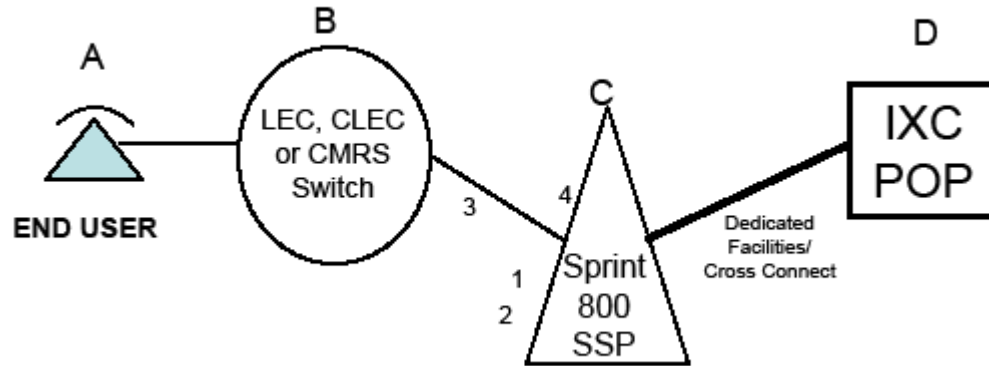

- A. End user dials 8XX number
 - B. LEC, CLEC or CMRS carrier has agreement with Sprint to deliver 8XX Traffic to IXCs
 - C. Sprint Switch looks up IXC that should receive the call
 - D. Call is routed across FGD Trunks to Digital Crosse Connect System in IXC POP. Call is routed to IXC Switch which routes call across ISC network to customer that purchased the 8XX service
- SPRINT charges (Common Transport which includes; ⁽¹⁾Common Multiplexing (50%), ⁽²⁾Local Transport Termination (50%), ⁽³⁾Local Transport Facility (1 Mile) and ⁽⁴⁾Tandem Switching) 1/2 of SWB Tariff – Transport rate element

Issue Date:
October 15, 2009

Margaret R. Prendergast
Manager, Tariffs
6450 Sprint Parkway
Overland Park, KS 66251

Effective Date:
November 14, 2009

ACCESS SERVICE
RATES AND CHARGES

14. Call Flow Diagrams (Cont'd)

14.1 Transit Access – Indirect Routing

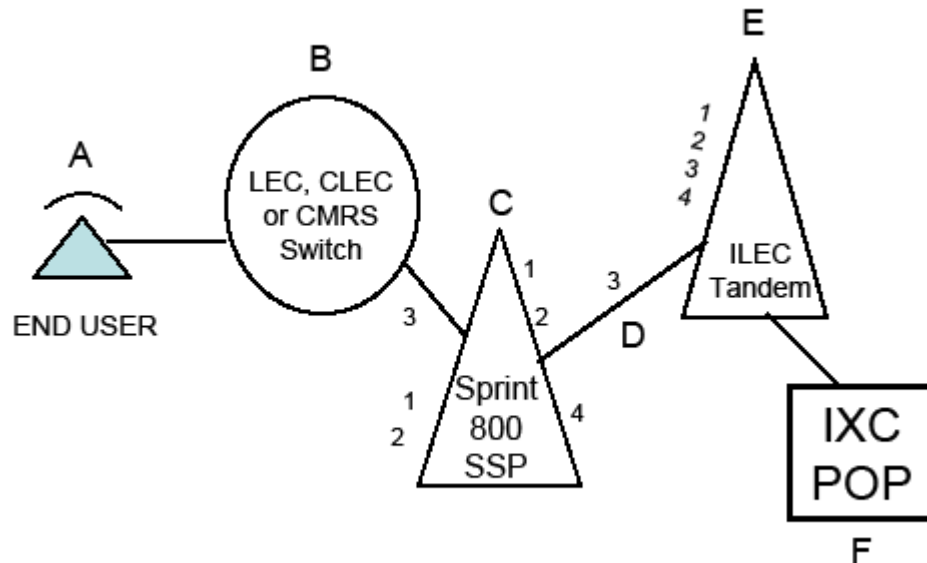

- A. End user dials 8XX number
 - B. LEC, CLEC or CMRS carrier has agreement with Sprint to deliver 8XX Traffic to IXCs
 - C. Sprint Switch looks up IXC that should receive the call
 - D. Call is routed across Shared Transport to Incumbent LEC's Access Tandem
 - E. Incumbent LEC routes call to IXC Feature Group D Trunk
 - F. Call is routed to IXC Switch which routes call across ISC network to customer that purchased the 8XX service
- SPRINT charges (Common Transport which includes: ⁽¹⁾Common Multiplexing, ⁽²⁾Local Transport Termination, ⁽³⁾Local Transport Facility (10 Mile) and ⁽⁴⁾Tandem Switching) SWB Tariff – Transport rate element

Issue Date:
October 15, 2009

Margaret R. Prendergast
Manager, Tariffs
6450 Sprint Parkway
Overland Park, KS 66251

Effective Date:
November 14, 2009

ACCESS SERVICE

15. Toll VoIP-PSTN (Continued)

15.1 General

Toll VoIP-PSTN traffic is defined as traffic exchanged between a Sprint Communications Company, L.P. end user and the customer in time division multiplexing ("TDM") format that originates and/or terminates in Internet protocol ("IP") format. This section governs the identification of Toll VoIP-PSTN traffic that is required to be compensated at interstate access rates (unless the parties have agreed otherwise) by the Federal Communications Commission in its Report and Order in WC Docket Nos. 10-90, etc., FCC Release No. 11-161 (Nov. 18, 2011) as modified by its Second Order on Second Order on Reconsideration, FCC Release No. 12-47 (April 25, 2012), and as codified in 47 C.F.R. 51.319 ("Reconsideration Order"), and unless Sprint and the Customer have agreed otherwise. Specifically, this section establishes the method of separating such traffic (referred to in this tariff as "Relevant VoIP-PSTN Traffic") from the customer's traditional intrastate access traffic, so that such Relevant VoIP-PSTN Traffic can be billed in accordance with the FCC Orders.

(C)
|
(C)

If a Toll Free Database Access Query charge is assessed on a Toll Free 8YY Traffic call, it will be rated at the charges as set forth in the appropriate section of this tariff.

15.1.1 Rating of Toll VoIP-PSTN Traffic

The Relevant VoIP-PSTN Traffic identified in accordance with this tariff section will be billed at rates equal to the Company's tariffed interstate switched access rates as provided in Sprint's Tariff F.C.C. No. 13, unless intrastate rates are lower in which case they will be rated at the intrastate charges. Intrastate VoIP-PSTN not required to be billed at the interstate rates pursuant to this Section will be billed in accordance with the intrastate rate provisions of this Tariff (absent an agreement between the company and the customer).

(C)
|
(C)

ACCESS SERVICE

15. Toll VoIP-PSTN (Continued) (N)

15.1 General

Toll VoIP-PSTN traffic is defined as traffic exchanged between a Sprint Communications Company, L.P. end user and the customer in time division multiplexing ("TDM") format that originates and/or terminates in Internet protocol ("IP") format. This section governs the identification of Toll VoIP-PSTN traffic that is required to be compensated at interstate access rates (unless the parties have agreed otherwise) by the Federal Communications Commission in its Report and Order in WC Docket Nos. 10-90, etc., FCC Release No. 11-161 (Nov. 18, 2011) ("FCC Order").

(D)
(D)

If a Toll Free Database Access Query charge is assessed on a Toll Free 8YY Traffic call, it will be rated at the charges as set forth in the appropriate section of this tariff.

(C)
|
(C)

15.1.1 Rating of Toll VoIP-PSTN Traffic

The Relevant VoIP-PSTN Traffic identified in accordance with this tariff section will be billed at rates equal to the Company's tariffed interstate switched access rates as provided in Sprint's Tariff F.C.C. No. 13, unless intrastate rates are lower in which case they will be rated at the intrastate charges.

(C)
|
(C)

(M)
|
(M)

(M) Material previously appearing on this page now appears on Page 15.5.

Issue Date:
June 13, 2012

Margaret R. Prendergast
Senior Manager - Tariffs
6450 Sprint Parkway
Overland Park, KS 66251

Effective Date:
July 13, 2012

Filed
Missouri Public
Service Commission
JX-2012-0806

ACCESS SERVICE

15. Toll VoIP-PSTN

(N)

15.1 General

Toll VoIP-PSTN traffic is defined as traffic exchanged between a Sprint Communications Company, L.P. end user and the customer in time division multiplexing (“TDM”) format that originates and/or terminates in Internet protocol (“IP”) format. This section governs the identification of Toll VoIP-PSTN traffic that is required to be compensated at interstate access rates (unless the parties have agreed otherwise) by the Federal Communications Commission in its Report and Order in WC Docket Nos. 10-90, etc., FCC Release No. 11-161 (Nov. 18, 2011) (“FCC Order”).

All traffic between Sprint Communications Company, L.P. and the end user originates and terminates in VoIP format.

Toll Free 8YY Transit Traffic Service and Toll Free Database Access Service are applicable to Toll VoIP-PSTN traffic and will be rated at the charges set forth in the appropriate section of this tariff.

15.1.1 Rating of Toll VoIP-PSTN Traffic

Because all the Company’s traffic is considered Relevant Toll VoIP-PSTN traffic it will be billed at rates equal to Sprint Communications Company, L.P. applicable tariffed interstate switched access rates as specified in Tariff F.C.C. No. 13.

Rate Per Access Minute

	<u>Direct Connect</u>	<u>Indirect Connect</u>
Southwestern Bell Telephone Company FCC #73 (T18)	0.0034630	0.0035930
Embarq Local Operating Companies FCC #1 (T9)	0.0044810	0.0051610
CenturyLink Operating Companies FCC #2 (T5)	0.0058208	0.0065506
All other ILEC areas	0.0034630	0.0035930 (N)

Issue Date:
December 16, 2011

Margaret R. Prendergast
Senior Manager - Tariffs
6450 Sprint Parkway
Overland Park, KS 66251

Effective Date:
January 15, 2012

CANCELLED
July 13, 2012
Missouri Public
Service Commission
JX-2012-0806

FILED
Missouri Public
Service Commission
JX-2012-0274

ACCESS SERVICE

15. Toll VoIP-PSTN (Continued)

(N)

14.2 Calculation and Application of Percent-VoIP-Usage Factor

Sprint will determine the number of Relevant Toll VoIP-PSTN Traffic minutes of use ("MOU") to which interstate rates will be applied under subsection 14.1.1, above, by applying a Percent VoIP Usage ("PVU") factor to the total intrastate access MOU exchanged between the Sprint's end user and the customer. The PVU will be derived and applied as follows:

- (1) The customer will calculate and furnish to Sprint a factor for Percentage VoIP Usage - Customer ("PVU-C") representing the percentage of the total intrastate and interstate access MOU that the customer exchanges with the Sprint in the State, that (a) is sent to Sprint and that originated in IP format; or (b) is received from Sprint and terminated in IP format. This PVU-C shall be based on information such as the number of the customer's retail VoIP subscriptions in the state (e.g., as reported on FCC Form 477), traffic studies, actual call detail, or other relevant and verifiable information.
- (2) Sprint will, likewise, calculate a factor for Percentage VoIP Usage - Sprint ("PVU-S") representing the percentage of Sprint's total intrastate and interstate access MOU in the State that Sprint originates or terminates on its network in IP format. This PVU-S shall be based on information such as the number of Sprint's retail VoIP subscriptions in the state (e.g., as reported on FCC Form 477), traffic studies, actual call detail, or other relevant and verifiable information.
- (3) Sprint will use the PVU-C and PVU-S factors to calculate a PVU factor that represents the percentage of total intrastate and interstate access MOU exchanged between Sprint's end user and the customer that is originated or terminated in IP format, whether at Sprint's end, at the customer's end, or at both ends. The PVU factor will be calculated as the sum of (A) the PVU-C factor and (B) the PVU-S factor times (1.0 minus the PVU-C factor).

(N)

Issue Date:
June 13, 2012

Margaret R. Prendergast
Senior Manager - Tariffs
6450 Sprint Parkway
Overland Park, KS 66251

Effective Date:
July 13, 2012

CANCELLED
June 16, 2021
Missouri Public
Service Commission
TD-2021-0319

Filed
Missouri Public
Service Commission
JX-2012-0806

ACCESS SERVICE

15. Toll VoIP-PSTN (Continued)

(N)

14.2 Calculation and Application of Percent-VoIP-Usage Factor (Continued)

- (4) Sprint will apply the PVU factor to the total intrastate access MOU exchanged with the customer to determine the number of Relevant VoIP-PSTN Traffic MOUs.

Example 1: The PVU-S is 10% and the PVU-C is 40%. The PVU factor is equal to $40\% + (10\% \times 60\%) = 46\%$. The Company will bill 46% of the customer's intrastate access MOU at the Company's applicable tariffed interstate or intrastate switched access rates, whichever is lower.

Example 2: The PVU-S is 10% and the PVU-C is 0%. The PVU factor is $0\% + (10\% \times 100\%) = 10\%$. The Company will bill 10% of the customer's intrastate access MOU at the Company's applicable tariffed interstate or intrastate switched access rates, whichever is lower.

Example 3: The PVU-C is 100%. No matter what the PVU-S factor is, the PVU is 100%. The Company will bill 100% of the customer's intrastate access MOU at the Company's applicable tariffed interstate or intrastate switched access rates, whichever is lower.

- (5) If the customer does not furnish the Company with a PVU-C pursuant to the preceding paragraph 1, the Company will utilize a customer PVU-C of 0%.

14.3 Initial PVU Factor

In calculating the initial PVU, Sprint will take the customer-specified PVU-C into account retroactively to December 29, 2011, provided that the customer provides the factor to Sprint no later than July 13, 2012; otherwise, it will set the initial PVU equal to the PVU-S, as specified in subsection 14.2 (2) above.

(N)

Issue Date:
June 13, 2012

Margaret R. Prendergast
Senior Manager - Tariffs
6450 Sprint Parkway
Overland Park, KS 66251

Effective Date:
July 13, 2012

CANCELLED
June 16, 2021
Missouri Public
Service Commission
TD-2021-0319

Filed
Missouri Public
Service Commission
JX-2012-0806

ACCESS SERVICE

15. Toll VoIP-PSTN (Continued)

(N)

14.4 PVU Factor Updates

The customer may update the PVU-C factor quarterly using the method set forth in subsection 14.2 (1), above. If the customer chooses to submit such updates, it shall forward to Sprint, no later than 15 days after the first day of January, April, July and/or October of each year, a revised PVU-C factor based on data for the prior three months, ending the last day of December, March, June and September, respectively. Sprint will use the revised PVU-C to calculate a revised PVU. The revised PVU factor will apply prospectively and serve as the basis for billing until superseded by a new PVU.

14.5 PVU Factor Verification

Not more than once in any year, Sprint may ask the customer to verify the PVU-C factor furnished to Sprint and customer may ask Sprint to verify the PVU-S factor and the calculation of the PVU factor. The party so requested shall comply, and shall reasonably provide the records and other information used to determine the respective PVU-C and PVU-S factors.

14.6 Auditing Procedures

Sprint may dispute the Customer's PVU factor based upon:

- (1) A review of the requested data and information provided by the customer.
- (2) Sprint's reasonable review of other market information, F.C.C. reports on VoIP lines, such as F.C.C. Form 477 or state level results based on the F.C.C. Local Competition Report or other relevant data.
- (3) A change in the reported PVU factor by more than five percentage points from the preceding quarter.

If after review of the data and information, the customer and Sprint establish revised PVU factors, the company will begin using those revised PVU factors with the next bill period.

(N)

Issue Date:
June 13, 2012

Margaret R. Prendergast
Senior Manager - Tariffs
6450 Sprint Parkway
Overland Park, KS 66251

Effective Date:
July 13, 2012

ACCESS SERVICE

15. Toll VoIP-PSTN (Continued)

14.7 Rates and Charges for Toll VoIP-PSTN Traffic

Local Switching and Toll Free 8YY Transit Traffic service rates below are equal to the Company's applicable tariffed intrastate (for Originating) as located elsewhere in this tariff and interstate switched access rates as provided in Sprint's Tariff F.C.C. No. 13, unless the applicable intrastate rates are lower.

(1) Local Switching

	<u>Direct Connect Rate Per Access Minute</u>	<u>Indirect Connect Rate Per Access Minute</u>	
Originating	See FCC No. 13 ¹	See FCC No. 13 ¹	(T)
Terminating	See FCC No. 13 ¹	See FCC No. 13 ¹	(T)(R)

(2) Toll Free 8YY Transit Traffic Service

	<u>Direct Connect Rate Per Access Minute</u>	<u>Indirect Connect Rate Per Access Minute</u>
Originating	\$0.0033300	\$0.0066600
Terminating	\$0.0003410	\$0.0004180

Note 1: Billed at rates set forth in the Company's Interstate Access Services Tariff (FCC No. 13), as may be amended from time to time, located at http://www2.sprint.com/tariffs/pdf_files/file_10196.pdf . (N)
 (N)

Issue Date:
 June 30, 2014

Margaret R. Prendergast
 Manager - Tariffs
 6450 Sprint Parkway
 Overland Park, KS 66251

Effective Date:
 July 31, 2014

FILED
 Missouri Public
 Service Commission
 JX-2014-0561

ACCESS SERVICE

15. Toll VoIP-PSTN (Continued)14.7 Rates and Charges for Toll VoIP-PSTN Traffic

Local Switching and Toll Free 8YY Transit Traffic service rates below are equal to the Company's applicable tariffed intrastate (for Originating) as located elsewhere in this tariff and interstate switched access rates as provided in Sprint's Tariff F.C.C. No. 13, unless the applicable intrastate rates are lower. (C)
(C)

(1) Local Switching

	<u>Direct Connect Rate</u> <u>Per Access Minute</u>	<u>Indirect Connect Rate</u> <u>Per Access Minute</u>
Originating		
Southwestern Bell Telephone Co.	\$0.0034630	\$0.0035930
Embarq Local Operating Co.	\$0.0044810	\$0.0051610
CenturyLink Operating Co.	\$0.0058208	\$0.0065506
All Other Carriers	\$0.0034630	\$0.0035930
Terminating		
Southwestern Bell Telephone Co.	\$0.0034630	\$0.0035930
Embarq Local Operating Co.	\$0.0044810	\$0.0051610
CenturyLink Operating Co.	\$0.0058208	\$0.0065506
All Other Carriers	\$0.0034630	\$0.0035930

(2) Toll Free 8YY Transit Traffic Service

	<u>Direct Connect Rate</u> <u>Per Access Minute</u>	<u>Indirect Connect Rate</u> <u>Per Access Minute</u>
Originating	\$0.0033300	\$0.0066600
Terminating	\$0.0003410	\$0.0004180

Issue Date:
September 25, 2012

Margaret R. Prendergast
Manager - Tariffs
6450 Sprint Parkway
Overland Park, KS 66251

Effective Date:
October 25, 2012

ACCESS SERVICE

15. Toll VoIP-PSTN (Continued) (N)

14.7 Rates and Charges for Toll VoIP-PSTN Traffic

Local Switching and Toll Free 8YY Transit Traffic service rates below are equal to the Company's applicable tariffed interstate switched access rates as provided in Sprint's Tariff F.C.C. No. 13, unless the applicable intrastate rates are lower.

(1) Local Switching

	<u>Direct Connect Rate</u> <u>Per Access Minute</u>	<u>Indirect Connect Rate</u> <u>Per Access Minute</u>	
Originating			
Southwestern Bell Telephone Co.	\$0.0034630	\$0.0035930	
Embarq Local Operating Co.	\$0.0044810	\$0.0051610	
CenturyLink Operating Co.	\$0.0058208	\$0.0065506	
All Other Carriers	\$0.0034630	\$0.0035930	
Terminating			
Southwestern Bell Telephone Co.	\$0.0034630	\$0.0035930	(M)
Embarq Local Operating Co.	\$0.0044810	\$0.0051610	
CenturyLink Operating Co.	\$0.0058208	\$0.0065506	(M)
All Other Carriers	\$0.0034630	\$0.0035930	(M)

(2) Toll Free 8YY Transit Traffic Service

	<u>Direct Connect Rate</u> <u>Per Access Minute</u>	<u>Indirect Connect Rate</u> <u>Per Access Minute</u>	
Originating	\$0.0033300	\$0.0066600	
Terminating	\$0.0003410	\$0.0004180	(N)

(M) Material now appearing on this page previously appeared on Page 15-1.

Issue Date:
June 13, 2012

Margaret R. Prendergast
Senior Manager - Tariffs
6450 Sprint Parkway
Overland Park, KS 66251

Effective Date:
July 13, 2012

Filed
Missouri Public
Service Commission
JX-2012-0806