

## **Missouri Network Alliance, LLC**

### REGULATIONS AND SCHEDULE OF INTRASTATE SWITCHED ACCESS CHARGES

This Tariff, filed with the Missouri Public Service Commission, contains the rates, terms and conditions applicable to the provision of intrastate switched access services in the State of Missouri by Missouri Network Alliance, LLC. This Tariff is on file with the Missouri Public Service Commission and copies may be inspected during normal business hours at the Company's principal place of business.

---

ISSUED: August 8, 2008

EFFECTIVE: September 30, 2008

Max B. Huffman, Chief Operating Officer  
Missouri Network Alliance, LLC  
9221 Ward Parkway, Suite 350  
Kansas City, MO 64114

**FILED**  
Missouri Public  
Service Commission

---

WAIVER OF RULES AND REGULATIONS

Pursuant to Case No. TA-2001-348, the following statutes and rules have been waived for purposes of offering access services as set forth herein:

STATUTES

392.210.2	Uniform System of Accounts
392.240(1)	Just & Reasonable Rates
392.270	Ascertain Property Values
392.280	Depreciation Accounts
392.290	Issuance of Securities
392.300.2	Acquisition of Stock
392.310	Issuance of Stock and Debt
392.320	Stock Dividend Payment
392.330	Issuance of Securities, Debts & Notes
392.340	Reorganizations

COMMISSION RULES

4 CSR 240-10.020	Depreciation Fund Income
4 CSR 240-30.010(2)(C)	Rate Schedules Should Be Posted at Central Office
4 CSR 240-30.040	Uniform System of Accounts
4 CSR 240-33.030	Inform Customer of Lowest Price
4 CSR 240-35	Bypass

---

ISSUED: August 8, 2008

EFFECTIVE: September 30, 2008

Max B. Huffman, Chief Operating Officer  
Missouri Network Alliance, LLC  
9221 Ward Parkway, Suite 350  
Kansas City, MO 64114

FILED  
Missouri Public  
Service Commission

TABLE OF CONTENTS

Title Page	Page 1
Waiver of Rules and Regulations	Page 2
Table of Contents	Page 3
Explanation of Symbols	Page 4
SECTION 1	GENERAL REGULATIONS
1.1	APPLICATION OF TARIFF..... 6
1.2	DEFINITIONS ..... 7
1.3	UNDERTAKING OF THE COMPANY ..... 10
SECTION 2	RULES AND REGULATIONS
2.1	USE OF FACILITIES AND SERVICE..... 12
2.2	MINIMUM PERIOD OF SERVICE..... 14
2.3	PAYMENT FOR SERVICES RENDERED ..... 15
2.4	DEPOSITS ..... 16
2.5	ADVANCE PAYMENTS ..... 17
2.6	DISPUTED BILLS ..... 17
2.7	INSPECTION, TESTING AND ADJUSTMENT ..... 18
2.8	SUSPENSION OR TERMINATION OF SERVICE ..... 19
2.9	OBLIGATIONS OF THE CUSTOMER ..... 25
2.10	DETERMINATION OF MILEAGE..... 29
2.11	CALCULATION OF MILEAGE ..... 30
SECTION 3	SWITCHED ACCESS
3.1	GENERAL ..... 32
3.2	RATE CLASSIFICATIONS..... 32
3.3	OBLIGATIONS OF THE COMPANY ..... 35
3.4	OBLIGATIONS OF THE CUSTOMER..... 37
3.5	RATE REGULATIONS ..... 38
SECTION 4	SPECIAL ARRANGEMENTS
4.1	SPECIAL CONSTRUCTION ..... 41
4.2	NON-ROUTINE INSTALLATION AND/OR MAINTENANCE..... 43
4.3	INDIVIDUAL CASE BASIS (ICB) ARRANGEMENTS..... 43
SECTION 5	RATES AND CHARGES ..... 44

ISSUED: August 8, 2008

EFFECTIVE: September 30, 2008

Max B. Huffman, Chief Operating Officer  
Missouri Network Alliance, LLC  
9221 Ward Parkway, Suite 350  
Kansas City, MO 64114

FILED  
Missouri Public  
Service Commission

EXPLANATION OF SYMBOLS

- (C) To signify changed rules or regulation\*
- (D) To signify discontinued rate or regulation
- (I) To signify increased rate
- (M) To signify matter relocated without change
- (N) To signify new rate or regulation
- (R) To signify reduced rate
- (S) To signify reissued matter
- (T) To signify a change in text but no change in rate or regulation
- (Z) To signify a correction

\* When used in reference to a rate, the symbol (C) indicates a change in the method of applying a rate which will result in either an increase or a decrease for certain customers.

---

ISSUED: August 8, 2008

EFFECTIVE: September 30, 2008

Max B. Huffman, Chief Operating Officer  
Missouri Network Alliance, LLC  
9221 Ward Parkway, Suite 350  
Kansas City, MO 64114

FILED  
Missouri Public  
Service Commission

CONTENTS

SECTION 1 - GENERAL REGULATIONS

	PAGE
1.1 APPLICATION OF TARIFF.....	6
1.2 DEFINITIONS .....	7
1.3 UNDERTAKING OF THE COMPANY .....	10

## SECTION 1 - GENERAL REGULATIONS

### 1.1 APPLICATION OF TARIFF

This Tariff contains regulations, rates and charges applicable to the provision of switched access services by Missouri Network Alliance, LLC to Customers in the State of Missouri. The Company may from time to time and in particular circumstances provide discounts or promotional offerings or otherwise waive or modify these general rates and regulations for potential customers. All such offerings will be submitted to the Commission in advance and will conform to the rules, regulations, and orders of the Commission.

The provision of service by the Company as set forth in this Tariff does not constitute a joint undertaking with any Customers for the furnishing of any service.

---

ISSUED: August 8, 2008

EFFECTIVE: September 30, 2008

Max B. Huffman, Chief Operating Officer  
Missouri Network Alliance, LLC  
9221 Ward Parkway, Suite 350  
Kansas City, MO 64114

FILED  
Missouri Public  
Service Commission

---

SECTION 1 - GENERAL REGULATIONS

1.2 DEFINITIONS

ACCESS CODE - Denotes a uniform code assigned by the Company to an individual Customer. The code has the form 101XXXX, 950-0XXX, or 950-1XXX.

ACCESS MINUTES - Denotes that usage of exchange facilities in intrastate service for the purpose of calculating chargeable usage.

ACCESS TANDEM - A switching system that provides a traffic concentration and distribution function for originating or terminating traffic between end offices and a Customer's premises.

ANSWER SUPERVISION - The transmission of the switch trunk equipment supervisory signal (off-hook or on-hook) to the Customer's point of termination as an indication that the called party has answered or disconnected.

CALL - A Customer attempt for which the complete address code is provided to the service end office.

CARRIER OR COMMON CARRIER - Any individual, partnership, association, corporation or other entity engaged in intrastate communication for hire by wire or radio between two or more exchanges.

CENTRAL OFFICE - A local Company switching system where exchange service Customer station loops are terminated for purposes of interconnection to each other and to trunks.

CHANNEL - A communications path between two or more points of termination.

COMMUNICATIONS SYSTEM - Denotes channels and other facilities which are capable of communications between terminal equipment provided by other than the Company.

COMPANY – Missouri Network Alliance, L.L.C. (“MNA”)

CUSTOMER - Any individual, partnership, association, corporation or other entity which subscribes to the services offered under this Tariff, including both Interexchange Carriers.

CUSTOMER DESIGNATED PREMISES - The premises specified by the Customer for termination of Access Services.

DUAL TONE MULTIFREQUENCY (DTMF) - Tone signaling, also known as touch tone signaling.

END OFFICE SWITCH - A Company switching system where exchange service Customer station loops are terminated for purposes of interconnection to each other and to trunks.

---

ISSUED: August 8, 2008

EFFECTIVE: September 30, 2008

Max B. Huffman, Chief Operating Officer  
Missouri Network Alliance, LLC  
9221 Ward Parkway, Suite 350  
Kansas City, MO 64114

FILED  
Missouri Public  
Service Commission

---

SECTION 1 - GENERAL REGULATIONS

1.2 DEFINITIONS (Cont'd)

END USER - Any Customer of an interstate telecommunications service that is not a Carrier or Common Carrier, except that a Carrier shall be deemed to be an End User when such Carrier uses a telecommunications service for administrative purposes. A person or entity that offers telecommunications service exclusively as a reseller shall be deemed to be an End User if all resale transmissions offered by such reseller originate on the premises of such reseller when making such service available to others, directly or indirectly.

ENTRY SWITCH - First point of switching.

EXCHANGE - A group of lines in a unit generally smaller than a LATA established by the Company for the administration of communications service in a specified area. An Exchange may consist of one or more central offices together with the associated facilities used in furnishing communications service within that area.

FACILITIES - Denotes any cable, poles, conduit, carrier equipment, wire center distribution frames, central office switching equipment, etc., utilized to provide the service offered under this Tariff.

FIRST POINT OF SWITCHING - The first Company location at which switching occurs on the terminating path of a call proceeding from the Customer premises to the terminating end office and, at the same time, the last Company location at which switching occurs on the originating path of a call proceeding from the originating end office to the Customer premises.

INTERSTATE COMMUNICATIONS - Any communications with that crosses over a state boundary. Interstate Communications includes interstate and international communications.

INTRASTATE COMMUNICATIONS - Any communication which originates and terminates within the same state and is subject to oversight by a state regulatory commission as provided by the laws of the state involved.

LOCAL ACCESS AND TRANSPORT AREA (LATA) - A geographic area established for the provision and administration of communications service. A LATA encompasses designated exchanges, which are grouped to serve common social, economic and other purposes.

LOCAL CALLING AREA - A geographical area, as defined in the Company's local or general exchange service Tariff in which an End User may complete a call without incurring toll usage charges.

MESSAGE - A Message is a Call as defined above.

OFF-HOOK - The active condition of Switched Access Service or a telephone exchange line.

---

ISSUED: August 8, 2008

EFFECTIVE: September 30, 2008

Max B. Huffman, Chief Operating Officer  
Missouri Network Alliance, LLC  
9221 Ward Parkway, Suite 350  
Kansas City, MO 64114

FILED  
Missouri Public  
Service Commission

## SECTION 1 - GENERAL REGULATIONS

### 1.2 DEFINITIONS (Cont'd)

**ON-HOOK** - The idle condition of Switched Access Service or a telephone exchange line.

**ORIGINATING DIRECTION** - The use of Switched Access Service for the origination of calls from an End User premises to a carrier's premises.

**POINT OF TERMINATION** - The point of demarcation within a Customer-designated premises at which the Company's responsibility for the provision of access service ends. The point of demarcation is the point of interconnection between Company communications facilities and Customer-provided facilities as defined in Part 68 of the Federal Communications Commission's Rules and Regulations.

**PREMISES** - A building or buildings on contiguous property, not separated by a public highway or right-of-way.

**SERVING WIRE CENTER** - The wire center from which the End-User normally obtains dial tone.

**SPECIAL ACCESS CIRCUIT** - The physical pathway for transmission of information between a dedicated originating point and a dedicated terminating point.

**TERMINATING DIRECTION** - The use of Switched Access Service for the completion of calls from a carrier's premises to an End User premises.

**TRANSMISSION PATH** - An electrical path capable of transmitting signals within the range of the service offering. A transmission path is comprised of physical or derived facilities consisting of any form or configuration of plant used in the telecommunications industry.

**TRUNK** - A communications path connecting two switching systems in a network, used in the establishment of an end-to-end connection.

**TRUNK GROUP** - A set of trunks which are traffic engineered as a unit for the establishment of connections between switching systems in which all of the communications paths are interchangeable.

**WIRE CENTER** - A physical location in which one or more central offices, used for the provision of exchange services, are located.

---

ISSUED: August 8, 2008

EFFECTIVE: September 30, 2008

Max B. Huffman, Chief Operating Officer  
Missouri Network Alliance, LLC  
9221 Ward Parkway, Suite 350  
Kansas City, MO 64114

FILED  
Missouri Public  
Service Commission

SECTION 1 - GENERAL REGULATIONS

1.3 UNDERTAKING OF THE COMPANY

The Company shall be responsible only for the installation, operation and maintenance of service which it provides and does not undertake to transmit messages under this Tariff.

Services provided under this Tariff are provided 24 hours a day, seven days per week, unless otherwise specified in applicable sections of this Tariff.

---

ISSUED: August 8, 2008

EFFECTIVE: September 30, 2008

Max B. Huffman, Chief Operating Officer  
Missouri Network Alliance, LLC  
9221 Ward Parkway, Suite 350  
Kansas City, MO 64114

FILED  
Missouri Public  
Service Commission

---

CONTENTS

SECTION 2 - RULES AND REGULATIONS

	PAGE
2.1 USE OF FACILITIES AND SERVICE .....	12
2.2 MINIMUM PERIOD OF SERVICE .....	14
2.3 PAYMENT FOR SERVICES RENDERED.....	15
2.4 DEPOSITS.....	16
2.5 ADVANCE PAYMENTS .....	17
2.6 DISPUTED BILLS.....	17
2.7 INSPECTION, TESTING AND ADJUSTMENT .....	18
2.8 SUSPENSION OR TERMINATION OF SERVICE.....	19
2.9 OBLIGATIONS OF THE CUSTOMER.....	25
2.10 DETERMINATION OF MILEAGE .....	29
2.11 CALCULATION OF MILEAGE.....	30

---

ISSUED: August 8, 2008

EFFECTIVE: September 30, 2008

Max B. Huffman, Chief Operating Officer  
Missouri Network Alliance, LLC  
9221 Ward Parkway, Suite 350  
Kansas City, MO 64114

FILED  
Missouri Public  
Service Commission

SECTION 2 - RULES AND REGULATIONS

2.1 USE OF FACILITIES AND SERVICE

2.1.1 Use of Service

- A) Service may be used for any lawful purpose by the Customer or by any End User.
- B) The Customer obtains no property right or interest in the use of any specific type of facility, service, equipment, number, process, or code. All right, title and interest to such items remain, at all times, solely with the Company.
- C) Recording of telephone conversations of service provided by the Company under this Tariff is prohibited except as authorized by applicable federal, state and local laws.
- D) Any service provided under this Tariff may be resold to or shared (jointly used) with other persons at the Customer's option. The Customer remains solely responsible for all use of service ordered by it or billed to its account(s) pursuant to this Tariff, for determining who is authorized to use its service, and for promptly notifying the Company of any unauthorized use. The Customer may advise its Customers that a portion of its service is provided by the Company, but the Customer shall not represent that the Company jointly participates with the Customer in the provision of the service.

---

ISSUED: August 8, 2008

EFFECTIVE: September 30, 2008

Max B. Huffman, Chief Operating Officer  
Missouri Network Alliance, LLC  
9221 Ward Parkway, Suite 350  
Kansas City, MO 64114

FILED  
Missouri Public  
Service Commission

---

SECTION 2 - RULES AND REGULATIONS

2.1 USE OF FACILITIES AND SERVICE (Cont'd)

2.1.2 Limitations

- A) Service is offered subject to the availability of the necessary facilities and/or equipment and subject to the provisions of this Tariff. The Company may decline applications for service to or from a location where the necessary facilities or equipment are not available. The Company may discontinue furnishing service in accordance with the terms of this Tariff.
- B) The Company reserves the right to discontinue or limit service when necessitated by conditions beyond its control (examples of these conditions are more fully set forth elsewhere in this Tariff), or when service is used in violation of provisions of this Tariff or the law.
- C) The Company does not undertake to transmit messages, but offers the use of its service when available, and, as more fully set forth elsewhere in this Tariff, shall not be liable for errors in transmission or for failure to establish connections.
- D) The Company reserves the right to discontinue service, limit service, or to impose requirements as required to meet changing regulatory or statutory rules and standards, or when such rules and standards have an adverse material affect on the business or economic feasibility of providing service, as determined by the Company in its reasonable judgment.
- E) The Company reserves the right to refuse an application for service made by a present or former Customer who is indebted to the Company for service previously rendered pursuant to this Tariff until the indebtedness is satisfied.

---

ISSUED: August 8, 2008

EFFECTIVE: September 30, 2008

Max B. Huffman, Chief Operating Officer  
Missouri Network Alliance, LLC  
9221 Ward Parkway, Suite 350  
Kansas City, MO 64114

FILED  
Missouri Public  
Service Commission

## SECTION 2 - RULES AND REGULATIONS

### 2.1 USE OF FACILITIES AND SERVICE (Cont'd)

#### 2.1.3 Use and Ownership of Equipment

The Company's equipment, apparatus, channels and lines shall be carefully used. Equipment furnished by the Company shall remain its property and shall be returned to the Company whenever requested, within a reasonable period following the request, in good condition (subject to reasonable wear and tear). The Customer is required to reimburse the Company for any loss of, or damage to, the facilities or equipment on the Customer's premises, including loss or damage caused by agents, employees or independent contractors of the Customer through any negligence.

### 2.2 MINIMUM PERIOD OF SERVICE

The minimum period for which services are provided and for which rates and charges are applicable is one month unless otherwise specified. When a service is discontinued prior to the expiration of the minimum period, charges are applicable, whether the service is used or not.

---

ISSUED: August 8, 2008

EFFECTIVE: September 30, 2008

Max B. Huffman, Chief Operating Officer  
Missouri Network Alliance, LLC  
9221 Ward Parkway, Suite 350  
Kansas City, MO 64114

FILED  
Missouri Public  
Service Commission

SECTION 2 - RULES AND REGULATIONS

2.3 PAYMENT FOR SERVICE RENDERED

2.3.1 Service is provided and billed on a monthly basis. Bills are due and payable upon receipt. In the event that the Company incurs fees or expenses, including attorney's fees, collecting, or attempting to collect, any charges owed to the Company, the Company may charge the Customer all such fees and expenses reasonably incurred, including a collection fee on the overdue charges accruing at the rate of 1.5% per month or the highest rate allowed by law, whichever is lower. Collection fees on overdue charges shall begin to accrue when the Account is assigned to an outside collection agency. Such collection fees are separate and distinct from attorney's fees and other costs incurred in collecting charges owed to the Company.

2.3.2 The Customer is responsible for payment of all charges for service furnished to the Customer, or the Customer's agents, End Users or Customers. All charges due by the Customer are payable to the Company or to the Company's authorized billing agent. Any objections to billed charges must be reported promptly to the Company in accordance with Section 2.6 following.

2.3.3 The Company reserves the right to assess a charge of \$20.00 whenever a check or draft presented for payment of service is not accepted by the institution upon which it is written. The foregoing shall not limit the Company's right to discontinue service for returned checks or drafts.

2.3.4 Application of Late Payment Charge

Late payment charges do not apply to final accounts.

---

ISSUED: August 8, 2008

EFFECTIVE: September 30, 2008

Max B. Huffman, Chief Operating Officer  
Missouri Network Alliance, LLC  
9221 Ward Parkway, Suite 350  
Kansas City, MO 64114

FILED  
Missouri Public  
Service Commission

---

**SECTION 2 - RULES AND REGULATIONS****2.4 DEPOSITS**

- 2.4.1 The Company reserves the right to examine the credit record of the Customer. If the Customer's financial condition is unknown or unacceptable to the Company, the Customer may be required to provide the Company with a security deposit which the Company may apply against overdue charges. The amount of the security deposit shall be equal to two month's estimated usage but may vary with the Customer's credit history and projected usage. The Customer shall be apprised that after one year of service the Account shall be reviewed, and in the event that all amounts due have been paid within the terms and conditions of this Tariff, the deposit shall be refunded in full. If subsequent payment or usage patterns change, the Company may request an increase in or resubmission of the security deposit as appropriate. The Company may also require a security deposit before service is restored (along with the payment of overdue charges) from the Customer whose service has been discontinued for nonpayment of overdue charges. Such security deposit may be based on a new credit history (taking into account the discontinuance of service) and estimates of usage.
- 2.4.2 The fact that a security deposit has been made in no way relieves the Customer from the prompt payment of bills upon presentation.
- 2.4.3 If the amount of a deposit is proven to be less than required to meet the requirements specified above, the Customer shall be required to pay an additional deposit upon request.
- 2.4.4 When a deposit is to be returned, the Customer may request that the full amount of the deposit be issued by check. If the Customer requests that the full amount be credited to amounts owed the Company, the Company will apply the deposit to any amount currently owed to the Company, and return any remaining amount of the deposit to the Customer by check.

---

ISSUED: August 8, 2008

EFFECTIVE: September 30, 2008

Max B. Huffman, Chief Operating Officer  
Missouri Network Alliance, LLC  
9221 Ward Parkway, Suite 350  
Kansas City, MO 64114

FILED  
Missouri Public  
Service Commission

---

SECTION 2 - RULES AND REGULATIONS

2.5 ADVANCE PAYMENTS

The Company reserves the right to require an advance payment from the Customer instead of or in addition to a security deposit. The advance payment shall be in an amount equal to or less than estimated installation charges plus two months estimated billing.

2.6 DISPUTED BILLS

In the case of a billing dispute between the Customer and the Company for service furnished to the Customer, which cannot be settled with mutual satisfaction, the Customer may, within (30) days of the date of the bill containing the disputed amount, request an in-depth investigation and review of the disputed amount. The Company shall comply with the request. (The undisputed portion and subsequent bills must be paid on a timely basis or service shall be subject to cancellation under Section 2.8 following). The Company shall communicate to the Customer the results of such investigation and review as soon as reasonably possible. If the dispute notification is not made within thirty (30) days of the bill date, the bill will be considered final.

---

ISSUED: August 8, 2008

EFFECTIVE: September 30, 2008

Max B. Huffman, Chief Operating Officer  
Missouri Network Alliance, LLC  
9221 Ward Parkway, Suite 350  
Kansas City, MO 64114

FILED  
Missouri Public  
Service Commission

SECTION 2 - RULES AND REGULATIONS

2.7 INSPECTION, TESTING AND ADJUSTMENT

- 2.7.1 The Company may, upon reasonable notice, make such tests and inspections as may be necessary to determine whether the terms and conditions of this Tariff are being complied with in the installation, operation or maintenance of the Customer's or the Company's facilities or equipment. The Company may interrupt service at any time, without penalty or liability, due to the departure from or reasonable suspicion of the departure from any of these terms and conditions.
- 2.7.2 The Customer shall be responsible for making arrangements or obtaining permission for safe and reasonable access for Company employees or agents of the Company to enter the premises of the Customer or any joint user or Customer of the Customer at any reasonable hour for the purpose of inspecting, repairing, testing or removing any part of the Company's facilities.
- 2.7.3 Upon reasonable notice, the facilities or equipment provided by the Company shall be made available to the Company for such tests and adjustments as may be necessary for their maintenance in a condition satisfactory to the Company. No interruption allowance shall be granted for the time during which such tests and adjustments are made, unless such interruption exceeds twenty-four hours in length and is requested by the Customer.

---

ISSUED: August 8, 2008

EFFECTIVE: September 30, 2008

Max B. Huffman, Chief Operating Officer  
Missouri Network Alliance, LLC  
9221 Ward Parkway, Suite 350  
Kansas City, MO 64114

FILED  
Missouri Public  
Service Commission

SECTION 2 - RULES AND REGULATIONS

2.8 SUSPENSION OR TERMINATION OF SERVICE

2.8.1 Suspension or Termination for Nonpayment

In the event that any bill rendered or any deposit required is not paid, the Company may suspend service or terminate service until the bill or the required deposit has been paid. If service is suspended or terminated for nonpayment, the Customer must remit a Connection Charge as well as any payment due and any applicable deposits prior to re-connection.

Suspension or termination shall not be made until:

- A) At least ten (10) days after written notification has been served personally on the Customer, or at least twenty (20) days after written notification has been mailed to the billing address of the Customer or;
- B) At least ten (10) days after the Customer has either signed for or refused a registered letter containing written notification mailed to the billing address of the Customer.

Access service shall not be suspended or terminated for nonpayment on weekends, public holidays, other federal and state holidays proclaimed by the President or the Governor, or on days when the main business office of the Company is not open for business.

---

ISSUED: August 8, 2008

EFFECTIVE: September 30, 2008

Max B. Huffman, Chief Operating Officer  
Missouri Network Alliance, LLC  
9221 Ward Parkway, Suite 350  
Kansas City, MO 64114

FILED  
Missouri Public  
Service Commission

SECTION 2 - RULES AND REGULATIONS

2.8 SUSPENSION OR TERMINATION OF SERVICE (Cont'd)

2.8.2 Exceptions to Suspension and Termination

Access service shall not be suspended or terminated for:

- A) Nonpayment of bills rendered for charges other than access service or deposits requested in connection with access service;
- B) Nonpayment for service for which a bill has not been rendered;
- C) Nonpayment for service which have not been rendered;
- D) Nonpayment of any billed charge which is in dispute or for the nonpayment of a deposit which is in dispute during the period before a determination of the dispute is made by the Company in accordance with Company's complaint handling procedures.
- E) Access service may be suspended or terminated for nonpayment of the undisputed portion of a disputed bill or deposit if the Customer does not pay the undisputed portion after being asked to do so.

---

ISSUED: August 8, 2008

EFFECTIVE: September 30, 2008

Max B. Huffman, Chief Operating Officer  
Missouri Network Alliance, LLC  
9221 Ward Parkway, Suite 350  
Kansas City, MO 64114

FILED  
Missouri Public  
Service Commission

SECTION 2 - RULES AND REGULATIONS

2.8 SUSPENSION OR TERMINATION OF SERVICE (Cont'd)

2.8.3 Verification of Nonpayment

Access service shall not be suspended or terminated for nonpayment of a bill rendered or a required deposit unless the Company has verified, in a manner approved by the Commission, that payment has not been received at any office of the Company or at any office of an authorized collection agent through the end of the period indicated in the notice.

---

ISSUED: August 8, 2008

EFFECTIVE: September 30, 2008

Max B. Huffman, Chief Operating Officer  
Missouri Network Alliance, LLC  
9221 Ward Parkway, Suite 350  
Kansas City, MO 64114

FILED  
Missouri Public  
Service Commission

SECTION 2 - RULES AND REGULATIONS

2.8 SUSPENSION OR TERMINATION OF SERVICE (Cont'd)

2.8.4 Termination For Cause Other Than Nonpayment

A) General

The Company, after notice in writing to the Customer and after having given the Customer an appropriate opportunity to respond to such notice, may terminate service and sever the connection(s) from the Customer's premises under the following conditions:

1. in the event of prohibited, unlawful or improper use of the facilities or service, or any other violation by the Customer of the rules and regulations governing the facilities and service furnished, or
2. if, in the judgment of the Company, any use of the facilities or service by the Customer may adversely affect the Company's personnel, plant, property or service. The Company shall have the right to take immediate action, including termination of the service and severing of the connection, without notice to the Customer when injury or damage to telephone personnel, plant, property or service is occurring, or is likely to occur, or
3. in the event of unauthorized use, where the Customer fails to take reasonable steps to prevent the unauthorized use of the facilities or service received from the Company, or
4. in the event that service is connected for a Customer who is indebted to the Company for service or facilities previously furnished, that service may be terminated by the Company unless the Customer satisfies the indebtedness within twenty (20) days after written notification.

---

ISSUED: August 8, 2008

EFFECTIVE: September 30, 2008

Max B. Huffman, Chief Operating Officer  
Missouri Network Alliance, LLC  
9221 Ward Parkway, Suite 350  
Kansas City, MO 64114

FILED  
Missouri Public  
Service Commission

---

SECTION 2 - RULES AND REGULATIONS

2.8 SUSPENSION OR TERMINATION OF SERVICE (Cont'd)

2.8.4 Termination For Cause Other Than Nonpayment (cont'd)

B) Prohibited, Unlawful or Improper Use of the Facilities or Service

Prohibited, unlawful or improper use of the facilities or service includes, but is not limited to:

1. The use of facilities or service of the Company without payment of Tariff charges;
2. Permitting fraudulent use.

C) Abandonment or Unauthorized Use of Facilities

1. If it is determined that facilities have been abandoned, or are being used by unauthorized persons, or that the Customer has failed to take reasonable steps to prevent unauthorized use, the Company may terminate access service.
2. In the event that access service is terminated for abandonment of facilities or unauthorized use and service is subsequently restored to the same Customer at the same location:
  - a. No charge shall apply for the period during which service had been terminated, and
  - b. Reconnection charges will apply when service is restored. However, no charge shall be made for reconnection if the service was terminated due to an error on the part of the Company.

SECTION 2 - RULES AND REGULATIONS

2.8 SUSPENSION OR TERMINATION OF SERVICE (Cont'd)

2.8.4 Termination For Cause Other Than Nonpayment (cont'd)

D) Change in the Company's Ability to Secure Access

Any change in the Company's ability (a) to secure and retain suitable facilities and rights for the construction and maintenance of the necessary circuits and equipment or (b) to secure and retain suitable space for its plant and facilities in the building where service is provided to the Customer may require termination of a Customer's service until such time as new arrangements can be made. No charges will be assessed the Customer while service is terminated, and no connection charges will apply when the service is restored.

---

ISSUED: August 8, 2008

EFFECTIVE: September 30, 2008

Max B. Huffman, Chief Operating Officer  
Missouri Network Alliance, LLC  
9221 Ward Parkway, Suite 350  
Kansas City, MO 64114

FILED  
Missouri Public  
Service Commission

SECTION 2 - RULES AND REGULATIONS

2.8 SUSPENSION OR TERMINATION OF SERVICE (Cont'd)

2.8.5 Emergency Termination of Service

The Company will immediately terminate the service of any Customer, on request, when the Customer has reasonable belief that the service is being used by an unauthorized person or persons. The Company may require that the request be submitted in writing as a follow-up to a request made by telephone.

2.9 OBLIGATIONS OF THE CUSTOMER

2.9.1 Damages

The Customer shall reimburse the Company for damages to Company facilities utilized to provide services under this Tariff caused by the negligence or willful act of the Customer, or resulting from improper use of the Company's facilities, or due to malfunction of any facilities or equipment provided by other than the Company, except that no Customer shall be liable for another Customer's actions.

2.9.2 Ownership of Facilities

Facilities utilized by the Company to provide service under the provisions of this Tariff shall remain the property of the Company. Such facilities shall be returned to the Company by the Customer, whenever requested, within a reasonable period following the request in as good condition as reasonable wear permits.

SECTION 2 - RULES AND REGULATIONS

2.9 OBLIGATIONS OF THE CUSTOMER (Cont'd)

2.9.3 Equipment Space and Power

The Customer shall furnish to the Company, at no charge, equipment space and electrical power required by the Company to provide services under this Tariff at the points of termination of such services. The selection of AC or DC power shall be mutually agreed to by the Customer and the Company. The Customer shall make necessary arrangements in order that the Company will have access to such spaces at reasonable times for installation, testing, repair, maintenance or removal of Company service.

2.9.4 Testing

The services provided under this Tariff shall be made available to the Company at mutually agreed upon times in order to permit the Company to test, adjust and maintain the services in satisfactory operating condition. No credit will be allowed for any interruption during such tests and adjustments.

2.9.5 Design of Customer Services

The Customer shall be responsible for its own expense for the overall design of its services and for any redesigning or rearrangements of its services which may be required because of changes in facilities, operations or procedures of the Company, minimum protection criteria or operating or maintenance characteristics of the facilities.

2.9.6 Network Contingency Coordination

The Customer shall, in cooperation with the Company, coordinate in planning the actions to be taken to maintain maximum network capability following natural or man-made disasters which affect telecommunications service.

---

**SECTION 2 - RULES AND REGULATIONS****2.9 OBLIGATIONS OF THE CUSTOMER (Cont'd)****2.9.7 Jurisdictional Reports**

For Switched Access services, the Company will use the percentage of interstate originating Feature Group D usage as derived from actual call detail records to determine the Percent of Interstate Usage (PIU) to apply to originating switched access services provided by the Company to the Customer. The Company will use the percentage of interstate terminating Feature Group D usage as derived from actual call detail records to determine the Percent of Interstate Usage (PIU) to apply to terminating switched access services provided by the Company to the Customer.

When the Company receives insufficient call detail to determine the jurisdiction of some or all originating and terminating access minutes of use, the Company will apply the PIU factor(s) provided by the customer or developed by the Company to those minutes of use for which the Company does not have sufficient call detail. Such PIU factor(s) will be used until the customer provides an update to its PIU factor(s) as set forth below. For all flat rated Switched Access Services, the Company will apply the PIU factor(s) as provided by the customer or developed by the Company as set forth below, each month until the customer provides an update to its PIU factor(s).

The customer will provide a projected PIU for each Switched Access Service for each end office when placing its order to add or discontinue services. Such PIU factors are applied to all usage rated, where the Company does not receive sufficient call detail to determine the jurisdiction of the usage.

If the customer does not supply the revised reports, the Company will assume the percentages to be the same as those provided in the last quarterly report. For those cases in which a quarterly report has never been received from the customer, the Company will assume the percentages to be the same as those provided in the customer's order for service or as developed by the Company as specified.

---

**SECTION 2 - RULES AND REGULATIONS****2.9 OBLIGATIONS OF THE CUSTOMER (Cont'd)****2.9.7 Jurisdictional Reports (Cont'd)**

Effective on the first of January, April, July and October of each year, the customer shall update its interstate and intrastate jurisdictional report. The customer shall forward to the Company, to be received no later than fifteen (15) days after the first of each such month, a revised report showing the interstate and intrastate percentage of use for the past three months ending the last day of December, March, June and September, respectively, for each service arranged for interstate use. Such revised report will serve as the basis for the next three month's billing for determining the jurisdiction for Switched Access Services in cases where the Company does not have sufficient call detail to do so and will be effective on the bill date for that service.

No prorating or back billing will be done based on the revised report. If the customer does not supply the revised reports, the Company will assume the percentages to be the same as those provided in the last quarterly report. For those cases in which a quarterly report has never been received from the customer, the Company will assume the percentages to be the same as those provided in the customer's order for service or as developed by the Company.

If a billing dispute arises or if a regulatory commission questions the projected PIU factor(s) provided by the customer, the Company may, by written request, require the customer to provide the data the customer used to determine the projected PIU factor(s). This written request will be considered the initiation of the audit. The customer shall supply the data to an independent auditor or the Company within thirty (30) days of the Company request. The customer shall keep records of call detail from which the percentage of interstate and intrastate use can be ascertained as set forth above, and upon request of the Company make the records available for inspection at an agreed upon location during normal business hours as reasonably necessary for purposes of verification of the percentages. The Company will audit data from one quarter unless a longer period is requested by the customer and agreed to by the Company.

---

SECTION 2 - RULES AND REGULATIONS

2.9 OBLIGATIONS OF THE CUSTOMER (Cont'd)

2.9.7 Jurisdictional Reports (Cont'd)

Audits may be conducted by: (1) the Company; (2) an independent auditor under contract to the Company; (3) a mutually agreed upon independent auditor paid for by the Company; or (4) an independent auditor selected and paid for by the customer. If the customer selects option (4), where it pays for its own independent audit, the selected auditor must certify that the audit was performed following Commission procedures for measuring interstate traffic as established by Commission Order, and provide the Company a report with supporting documentation to verify such procedures.

Verification audits may be conducted no more frequently than once per year except in extreme circumstances. The Company and customer will attempt to limit the audit to a reasonable time to effectively complete the audit. The Company and customer shall respond promptly to requests generated during the audit to ensure timely completion of the audit.

2.9.8 Mixed Interstate and Intrastate Access Service

When mixed interstate and intrastate Access Service is provided, all charges, including nonrecurring charges, usage charges, and optional features, will be prorated between interstate and intrastate. The percentage provided in the reports as set forth in Section 2.9.7 will serve as the basis for prorating the charges.

2.10 DETERMINATION OF MILEAGE

Services for which rates are mileage sensitive are rated on the airline distance between the Company's switch location and an End-User's End Office Switch.

## SECTION 2 - RULES AND REGULATIONS

## 2.11 CALCULATION OF MILEAGE

Airline mileage, where mileage is the basis for rating calls, is obtained by using the "V" and "H" coordinates assigned to each serving wire center and contained in NECA FCC Tariff No. 4 or successor Tariffs. To determine the airline distance between any two locations, proceed as follows:

- a. Obtain the "V" and "H" coordinates for each location. The "V" coordinate is the first four digits in the "VH" column. The "H" coordinate is the next four digits.
- b. Obtain the difference between the "V" coordinates of each of the locations. Obtain the difference between the "H" coordinates.
- c. Square each difference obtained in step b., above.
- d. Add the square of the "V" difference and the "H" difference obtained in step c., above.
- e. Divide the sum of the square by 10. Round to the next higher whole number if any fraction is obtained.
- f. Obtain the square root of the whole number result obtained above. Round to the next higher whole number if any fraction is obtained. This is the airline mileage.

Formula: 
$$\sqrt{\frac{(V_1 - V_2)^2 + (H_1 - H_2)^2}{10}}$$

---

CONTENTS

SECTION 3 - SWITCHED ACCESS SERVICE

	PAGE
3.1 GENERAL.....	32
3.2 RATE CLASSIFICATIONS.....	32
3.3 OBLIGATIONS OF THE COMPANY.....	35
3.4 OBLIGATIONS OF THE CUSTOMER.....	37
3.5 RATE REGULATIONS .....	38

---

ISSUED: August 8, 2008

EFFECTIVE: September 30, 2008

Max B. Huffman, Chief Operating Officer  
Missouri Network Alliance, LLC  
9221 Ward Parkway, Suite 350  
Kansas City, MO 64114

FILED  
Missouri Public  
Service Commission

---

## SECTION 3 - SWITCHED ACCESS SERVICE

### 3.1 GENERAL

Switched Access Service, which is available to Customers for their use in furnishing their services to End Users, provides a two-point electrical communications path between a Customer Designated Premises or Wire Center and an End User's End Office Switch. It provides for the use of Company terminating, switching and trunking facilities to originate and terminate calls from an End User's Serving Wire Center to a Customer's switching facilities point of interconnection. Feature Group D (FGD) switched access service is provided as trunk side switching through the use of access tandem switch trunk equipment. The switch trunk equipment is provided with SS7, wink-start, start-pulsing signals and answer and disconnect supervisory signaling. An Access Service Request ("ASR") will be used to place an Access Order for new service or to request change to an existing service. A Customer may order any number of services of the same type and between the same premises on a single Access Order. The Customer shall provide to the Company the order information required below:

- Customer name and premises address(es)
- Billing name and address
- Customer contact name(s) and telephone number(s) for all provisioning activities
- Specify the type of Entrance Facility to be used
- Specify directionality of the service

The application of rates for Switched Access Service is described in Section 3.2 following. The cancellation of an Access Order is described in Section 3.5.2 following.

### 3.2 RATE CLASSIFICATIONS

The classifications that apply to Switched Access Service, as provided by Company, are:

Switch Transport, comprised of  
Switched Facility  
Switched Termination  
Switching  
Entrance Facility  
Switch Port

---

**SECTION 3 - SWITCHED ACCESS SERVICE****3.2 RATE CLASSIFICATIONS (Cont'd)****3.2.1 Service Definition**

Switched Access Service is shared trunks that carry the combined traffic of more than one Interexchange Carrier from an end office to an access tandem where the calls are then switched onto trunks that are dedicated to individual Interexchange Carriers for transport from the access tandem to the wire center of the Customer Designated Premises. Switched Access Service is provisioned in two parts: (1) Switch Transport from the end office to the Company switch over shared circuits; (2) the Company Entrance Facility and Switch Port.

**3.2.2 Billing Components**

A) Switch Transport service is comprised of three parts: (1) a usage-based, distance sensitive Switch Facility component applied to the shared interoffice transmission between the end office and the Company switch, (2) a usage-based Switch Termination component applied at the Company end of the measured facility segment, and (3) the Company switching function. The mileage to be used to determine the rate for Switch Transport is calculated on the airline distance between the end office where the call carried by Switch Transport originates or terminates and the Customer Entrance Facility. Where applicable, the V&H coordinates method is used to determine mileage. This method is set forth in the National Exchange Carrier Association, Inc. Tariff F.C.C No. 4 for Wire Center Information.

B) Entrance Facility service recovers a portion of the costs associated with a communication path between a Customer Designated Premises at the wire center and the Company Switch Transport. Included as part of the Entrance Facility is a standard channel interface arrangement which defines the technical characteristics associated with the type of facilities to which the access service is to be connected at the Customer designated premise and the type of signaling capability, if any. A Customer's Switch Transport may be connected to the Entrance Facility of another Customer, providing the other Customer submits a Letter of Authorization for this connection and assumes full responsibility for the cost of the Entrance Facility.

---

ISSUED: August 8, 2008

EFFECTIVE: September 30, 2008

Max B. Huffman, Chief Operating Officer  
Missouri Network Alliance, LLC  
9221 Ward Parkway, Suite 350  
Kansas City, MO 64114

FILED  
Missouri Public  
Service Commission

SECTION 3 - SWITCHED ACCESS SERVICE

3.2 RATE CLASSIFICATIONS (Cont'd)

3.2.2 Billing Components (Cont'd)

C) Switch Port service provides the interface to the Company switch at the line rate of the Entrance Facility ordered by the Customer to the Customer Designated Premise. The quantity of ports is determined by the Customer and is based on the number of DS1 or DS3 channels ordered.

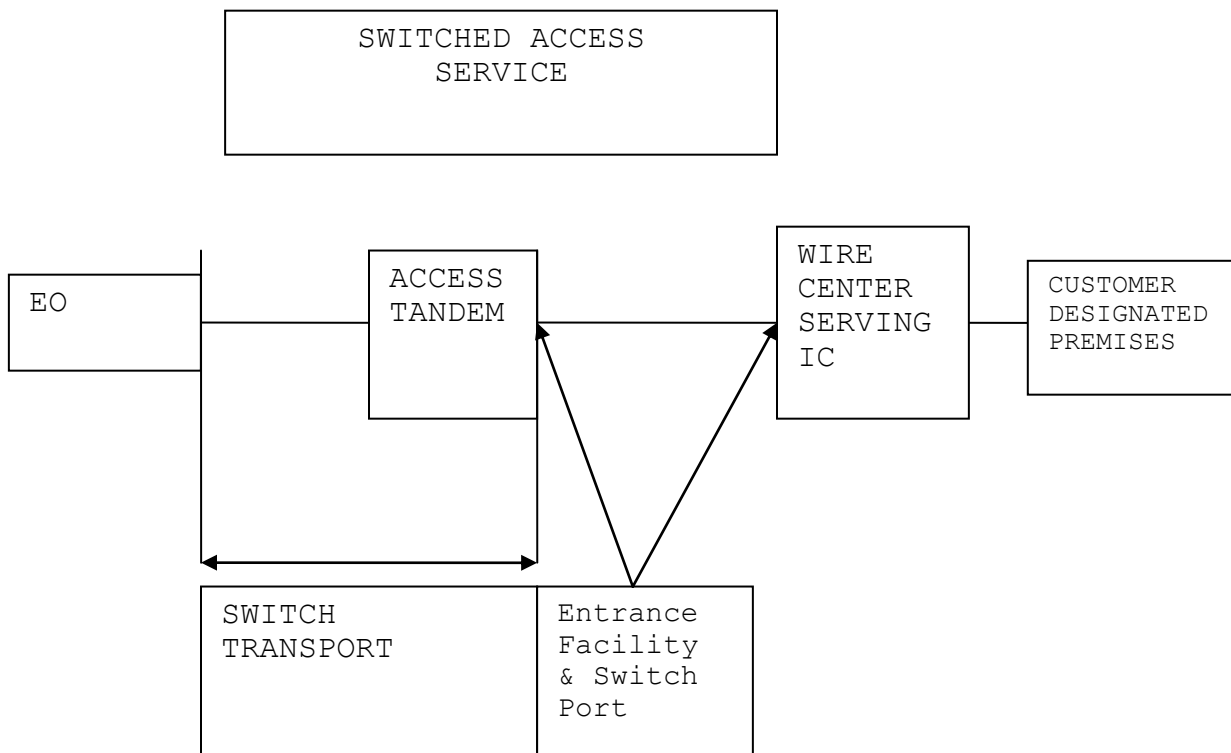

SECTION 3 - SWITCHED ACCESS SERVICE

3.3 OBLIGATIONS OF THE COMPANY

3.3 OBLIGATIONS OF THE COMPANY

The Company has certain obligations pertaining only to the provision of Switched Access Service. These obligations are as follows:

3.3.1 Network Management

The Company will administer its network to provide acceptable service levels to all telecommunications users of the Company's network services. Generally, service levels are considered acceptable only when both End Users and Customers are able to establish connections with little or no delay encountered within the Company's network. The Company maintains the right to apply protective controls, i.e., those actions, such as call gapping, which selectively cancel the completion of any traffic carried over its network, including that associated with a Customer's Switched Access Service. Generally, such protective measures would only be taken as a result of occurrences such as a failure or overload of Company or Customer facilities, natural disasters, mass calling or national security demands.

3.3.2 Design and Traffic Routing of Switched Access Service

The Company shall design and determine the routing of Switched Access Service, including the selection of the first point of switching, and the selection of facilities from the Customer Designated Premises to any switching point and to the end offices. The Company shall also decide if capacity is to be provided by originating only, terminating only, or two-way trunk groups. Selection of facilities and equipment and traffic routing of the service are based on standard engineering methods, available facilities and equipment and the Company's traffic routing plans.

---

ISSUED: August 8, 2008

EFFECTIVE: September 30, 2008

Max B. Huffman, Chief Operating Officer  
Missouri Network Alliance, LLC  
9221 Ward Parkway, Suite 350  
Kansas City, MO 64114

FILED  
Missouri Public  
Service Commission

---

**SECTION 3 - SWITCHED ACCESS SERVICE****3.3 OBLIGATIONS OF THE COMPANY (Cont'd)****3.3.3 Provision of Service Performance Data**

Subject to availability, end-to-end service performance data available to the Company through its own service evaluation routines, may also be made available to the Customer based on previously arranged intervals and format. The data provides information on overall end-to-end call completion and non-completion performance e.g., Customer equipment blockage, failure results and transmission performance. The data does not include service performance data provided under other Tariff sections, e.g., testing service results. If data is to be provided in other than paper format, the charges for such exchange will be determined on an individual case basis.

**3.3.4 Trunk Group Measurements Reports**

Subject to availability, the Company will make available trunk group data in the form of usage in CCS, peg count and overflow to the Customer based on previously agreed to intervals.

---

SECTION 3 - SWITCHED ACCESS SERVICE

3.4 OBLIGATIONS OF THE CUSTOMER

The Customer has certain specific obligations pertaining to the use of Switched Access Service.

3.4.1 Report Requirements

Customers are responsible for providing the following reports to the Company, when applicable.

(A) Jurisdictional Reports

When a Customer orders Switched Access Service for both interstate and intrastate use, the Customer is responsible for providing reports as set forth in Section 2 preceding. Charges will be apportioned in accordance with those reports.

3.4.2 On and Off-Hook Supervision

The Customer facilities shall provide the necessary on and off-hook supervision for accurate timing of calls.

3.4.3 Trunk Group Measurements Reports

With the agreement of the Customer, trunk group data in the form of usage in CCS, peg count and overflow for its end of all access trunk groups, where technologically feasible, will be made available to the Company. The data will be used to monitor trunk group utilization and service performance and will be based on previously arranged intervals and format.

### SECTION 3 - SWITCHED ACCESS SERVICE

#### 3.5 RATE REGULATIONS

This Section contains the specific regulations governing the rates and charges that apply for Switched Access Service.

Access Charges are applied on a per access minute basis. Access minute charges are accumulated over a monthly period.

##### 3.5.1 Minimum Periods

Switched Access Service is provided for a minimum period of one month.

##### 3.5.2 Cancellation of Access Service Order

A Customer may cancel an Access Order for the installation of service on any date prior to notification by the Company that service is available for the Customer's use or prior to the service date, whichever is later. The cancellation date is the date the Company receives written or verbal notice from the Customer that the order is to be canceled. The verbal notice must be followed by written confirmation within 10 days. If a Customer or End User is unable to accept Access Service within 30 calendar days of the original service date, the Access Order will be canceled and applicable charges will apply.

Prior to Firm Order Confirmation Date:

If an Access Order is canceled prior to the Firm Order Confirmation date, no charges will apply.

On or After Firm Order Confirmation Date:

If an Access Order is canceled on or after the Firm Order Confirmation date, the Customer will be billed a charge equal to the cost incurred in such installation less net salvage, or the charge for the minimum period.

---

**SECTION 3 - SWITCHED ACCESS SERVICE****3.5 RATE REGULATIONS (Cont'd)****3.5.3 Meet Point Billing**

Meet Point Billing is required when an access service is provided by multiple Telephone Companies for Feature Group D Switched Access Service. All billing, design and ordering arrangements will be consistent with Ordering and Billing Forum standards, Multiple Exchange Carrier Access Billing (MECAB) and Multiple Exchange Carrier Ordering and Design (MECOD). Any changes made to these arrangements by the Companies will be preceded by ninety (90) days prior written notice to affected Customers before implementation. It is the Company's intent to interconnect with sub-tending companies in a manner that reasonably balances the Company's ability to manage its network in cooperation with sub-tending companies while minimizing the transport costs jointly assessed the Customer by the Company and its subtending companies. Each Telephone Company jointly providing the access service will receive an Access Service Request ("order") or a copy of the order from the Customer as specified in Section 3.1 above. For usage rated access services the access minutes of use will generally be determined by the recording company. Where the recording company is not the bill rendering company, the recording company will provide detailed usage records to the bill rendering company to develop access minutes. A multiple bill-single tariff Meet Point Billing arrangement applies. Each company providing the access service will render an access bill to the Customer for its portion of the service based on its access tariff rates and regulations. The Customer will remit payment directly to each Bill Rendering Company. Billing Percentages (BP) will be determined and filed in the National Exchange Carrier Association, Inc. Tariff No. 4, which represents the portion of the service provided by each company.

---

ISSUED: August 8, 2008

EFFECTIVE: September 30, 2008

Max B. Huffman, Chief Operating Officer  
Missouri Network Alliance, LLC  
9221 Ward Parkway, Suite 350  
Kansas City, MO 64114

FILED  
Missouri Public  
Service Commission

CONTENTS

SECTION 4 - SPECIAL ARRANGEMENTS

	PAGE
4.1 SPECIAL CONSTRUCTION.....	41
4.2 NON-ROUTINE INSTALLATION AND/OR MAINTENANCE.....	43
4.3 INDIVIDUAL CASE BASIS (ICB) ARRANGEMENTS .....	43

---

ISSUED: August 8, 2008

EFFECTIVE: September 30, 2008

Max B. Huffman, Chief Operating Officer  
Missouri Network Alliance, LLC  
9221 Ward Parkway, Suite 350  
Kansas City, MO 64114

FILED  
Missouri Public  
Service Commission

---

SECTION 4 - SPECIAL ARRANGEMENTS

4.1 SPECIAL CONSTRUCTION

4.1.1 Subject to the arrangement of the Company and to all of the regulations contained in this tariff, special construction of facilities may be undertaken on a reasonable efforts basis at the request of the Customer. Special construction is that construction undertaken and characterized by one or more of the following:

- A) where facilities are not presently available and there is no other requirement for the facilities so constructed;
- B) of a type other than that which the Company would normally utilize in the furnishing of its services;
- C) where facilities are to be installed over a route other than that which the Company would normally utilize in the furnishing of its services;
- D) where facilities are requested in a quantity greater than that which the Company would normally construct;
- E) where installation is on an expedited basis;
- F) on a temporary basis until permanent facilities are available;

The basis for charges where the Company furnishes a facility or service for which a rate or charge is not specified in the Company's Tariffs will be based on the costs incurred by the Company (including return) and may include:

- nonrecurring charges;
- recurring charges;
- termination liabilities; or
- combinations of (a), (b), and (c).

---

SECTION 4 - SPECIAL ARRANGEMENTS

4.1 SPECIAL CONSTRUCTION (Cont'd)

4.1.2 Termination Liability

To the extent that there is no other requirement for use by the Company, a termination liability may apply for facilities specially constructed at the request of a Customer.

- A) The period on which the termination liability is based is the estimated service life of the facilities provided.
- B) The amount of the maximum termination liability is equal to the estimated amounts (including return) for:
  - 1. Costs to install the facilities to be provided including estimated costs for the rearrangements of existing facilities. These costs include:
    - a) equipment and materials provided or used;
    - b) engineering, labor, and supervision;
    - c) transportation; and
    - d) rights of way and/or any required easements;
  - 2. license preparation, processing, and related fees;
  - 3. Tariff preparation, processing and related fees;
  - 4. cost of removal and restoration, where appropriate; and
  - 5. any other identifiable costs related to the specially constructed or rearranged facilities.

## SECTION 4 - SPECIAL ARRANGEMENTS

## 4.2 NON-ROUTINE INSTALLATION AND/OR MAINTENANCE

At the Customer's request, installation and/or maintenance may be performed outside the Company's regular business hours, or (in the Company's sole discretion and subject to any conditions it may impose) in hazardous locations. In such cases, charges based on the cost of labor, material, and other costs incurred by or charged to the Company will apply. If installation is started during regular business hours but, at the Customer's request, extends beyond regular business hours into time periods including, but not limited to, weekends, holidays, and/or night hours, additional charges may apply.

## 4.3 INDIVIDUAL CASE BASIS (ICB) ARRANGEMENTS

Rates for ICB arrangements will be developed on a case-by-case basis in response to a bona fide request from a Customer or prospective Customer for the purposes of establishing interconnection which may vary from Tariff arrangements. Rates quoted in response to such requests may be different for Tariff services than those specified for such services in the Rate Attachment. ICB rates will be offered to Customers in writing and will be made available to similarly situated Customers

---

ISSUED: August 8, 2008

EFFECTIVE: September 30, 2008

Max B. Huffman, Chief Operating Officer  
Missouri Network Alliance, LLC  
9221 Ward Parkway, Suite 350  
Kansas City, MO 64114

FILED  
Missouri Public  
Service Commission

## SECTION 5 - RATES AND CHARGES

5.1 Switched Access Service

<u>A. Switch Transport #</u>	<u>Per Minute of Use</u>	
Call Miles		
0-100	\$ 0.00625	
Over 100	\$ 0.00758	
<u>B Entrance Facility</u>	<u>Monthly Rate</u>	<u>Non-recurring Charge</u>
DS1 (1.544 Mbps), Entrance Facility, Installation		\$ 150.00
DS1 (1.544 Mbps), Entrance Facility, per Point of Termination	\$ 87.00	
DS3 (44.736 Mbps), Entrance facility, Installation		\$ 500.00
DS3 (44.736 Mbps), Entrance facility, per Point of Termination	\$ 750.00	
Above DS3 Entrance facility, Installation		\$ ICB
Above DS3, Entrance facility, per Point of Termination	\$ ICB	
<u>C. Switch Port, per port</u>		
DS1 1.544 Mbps	\$ 37.00	\$ 50.00
DS3 44.736 Mbps	\$ 330.00	\$150.00
Above DS3	\$ ICB	\$ ICB

# End Office Trunking is not available.

ISSUED: August 8, 2008

EFFECTIVE: September 30, 2008

Max B. Huffman, Chief Operating Officer  
Missouri Network Alliance, LLC  
9221 Ward Parkway, Suite 350  
Kansas City, MO 64114

FILED  
Missouri Public  
Service Commission

## SECTION 5 - RATES AND CHARGES

5.2 Other Services

5.2.1 <u>Access Ordering</u>	<u>Non-Recurring Charge</u>
A. <u>Access Order Charge</u>	
- Per Order	\$ 136.00
B. <u>Service Date Change Charge</u>	
A Service Date Change Charge will apply, on a per order per occurrence basis, for each service date changed. The Access Order Charge as specified in 9.4.1(A) preceding does not apply.	
- Per Order	\$ 53.00
C. <u>Design Change Charge</u>	
The Design Change Charge will apply on a per order per occurrence basis, for each order requiring design change.	
- Per Order	\$ 53.00
D. <u>Miscellaneous Service Order Charge</u>	
- Per Occurrence	\$ 53.00

ISSUED: August 8, 2008

EFFECTIVE: September 30, 2008

Max B. Huffman, Chief Operating Officer  
 Missouri Network Alliance, LLC  
 9221 Ward Parkway, Suite 350  
 Kansas City, MO 64114

FILED  
 Missouri Public  
 Service Commission

## SECTION 5 - RATES AND CHARGES

5.2 Other Services (Cont'd)5.2.2 Additional Engineering, Labor and Maintenance

<u>Additional Engineering/Labor</u>	<u>First Hour or Fraction Thereof</u>
A. Basic Time per engineer normally scheduled working hours	\$ 85.00
B. Overtime per engineer outside of normally scheduled working hours	\$ 127.50
C. Premium Time outside of scheduled work day, per engineer	\$ 170.00

These charges are applicable for the following:

Additional Cooperative Acceptance testing  
 Additional Manual Testing  
 Maintenance of Service  
 Testing with Other Companies  
 Installation and Repair

ISSUED: August 8, 2008

EFFECTIVE: September 30, 2008

Max B. Huffman, Chief Operating Officer  
 Missouri Network Alliance, LLC  
 9221 Ward Parkway, Suite 350  
 Kansas City, MO 64114

FILED  
 Missouri Public  
 Service Commission

## SECTION 5 - RATES AND CHARGES

5.2	<u>Other Services</u> (Cont'd)	<u>Monthly Rate</u>	<u>Non-Recurring Charge</u>
5.2.3	<u>Specialized Service or Arrangements</u>	ICB	ICB
	Specialized Service or Arrangements are provided on an individual case basis.		
5.2.4	<u>Database Queries</u>		
		<u>Per Query</u>	
	800 Database Queries	\$0.003100	

ISSUED: August 8, 2008

EFFECTIVE: September 30, 2008

Max B. Huffman, Chief Operating Officer  
Missouri Network Alliance, LLC  
9221 Ward Parkway, Suite 350  
Kansas City, MO 64114

FILED  
Missouri Public  
Service Commission