

Missouri-American Water Company
Name of Issuing Corporation

For

Missouri Service Area
Community, Town or City

TABLE OF CONTENTS
Appendix

<u>Appendix Description</u>	<u>Sheet No.</u>
Typical Cross-Section – Domestic Water Service Line – St. Louis Operations Only	AP 1
Installation Requirement for Water Service Line – Company Main Parallel to Street – Parallel to Face of Premises	AP 2 & 3
Installation Requirements for Water Service Line – Company Main Not Parallel to Face of Premises	AP 4 & 5
Main Extension Termination – New Streets (Easements) – Multi-Lot Residential Subdivision – Last Lot	AP 6
Main Extension Termination – Existing Street (Easement) – Water Service Line to Individual Premises	AP 7
Installation Requirement – Master Water Service Line	AP 8 & 9
Installation Requirements – Master Water Service Line Commercial or Multi-Family Residential - Single or Multi-Story Buildings Served by a Meter(s)	AP 10
Alternate Installation Requirements – Domestic Water Service Line – Residential Single-Family Dwelling	AP 11 & 12
Installation Requirements – Domestic Water Service Line Residential – Duplex – Halves Owned or Rented	AP 13 & 14
Installation Requirements – Domestic Water Service Line – Residential Multi-Family; Multi-Level Buildings; Living Quarter Separately Owned	AP 15 & 16
Installation Requirements – Domestic Water Service Line – Residential Multi-Family; Multi-Level Buildings – Living Quarters Rented	AP 17
Installation Requirements – Domestic Water Service Line – Commercial – Single Story	AP 18
Installation Requirements – Domestic Water Service Line – Commercial – Multi-Story Building	AP 19 – 21
Face of a Premises	AP 22 & 23
Side of a Premises	AP 24
Domestic Service & Fire Suppression Utilizing Combination Service Line & “Fire Flow Meter” For Services Other than One or Two Family Dwellings Utilizing Combination Service Line/Residential	AP 25
Domestic Service & Fire Suppression for One or Two Family Dwellings Utilizing Combination Service Line/Residential	AP 26
Fire Service and Separate Domestic Service	AP 27
Split Service with Two Meter Boxes	AP 28

* Indicates new rate or text
+ Indicates change
DATE OF ISSUE: August 26, 2011

October 15, 2011
DATE OF EFFECTIVE: ~~October 1, 2011~~

ISSUED BY: Frank Kartmann, President
727 Craig Road, St. Louis, MO 63141

FILED
Missouri Public
Service Commission
JW-2012-0087

Missouri-American Water Company
Name of Issuing Corporation

For

Missouri Service Area (St. Louis Operations only)
Community, Town or City

**TYPICAL CROSS-SECTION – DOMESTIC WATER SERVICE LINE
(RESIDENTIAL OR COMMERCIAL PREMISES)**

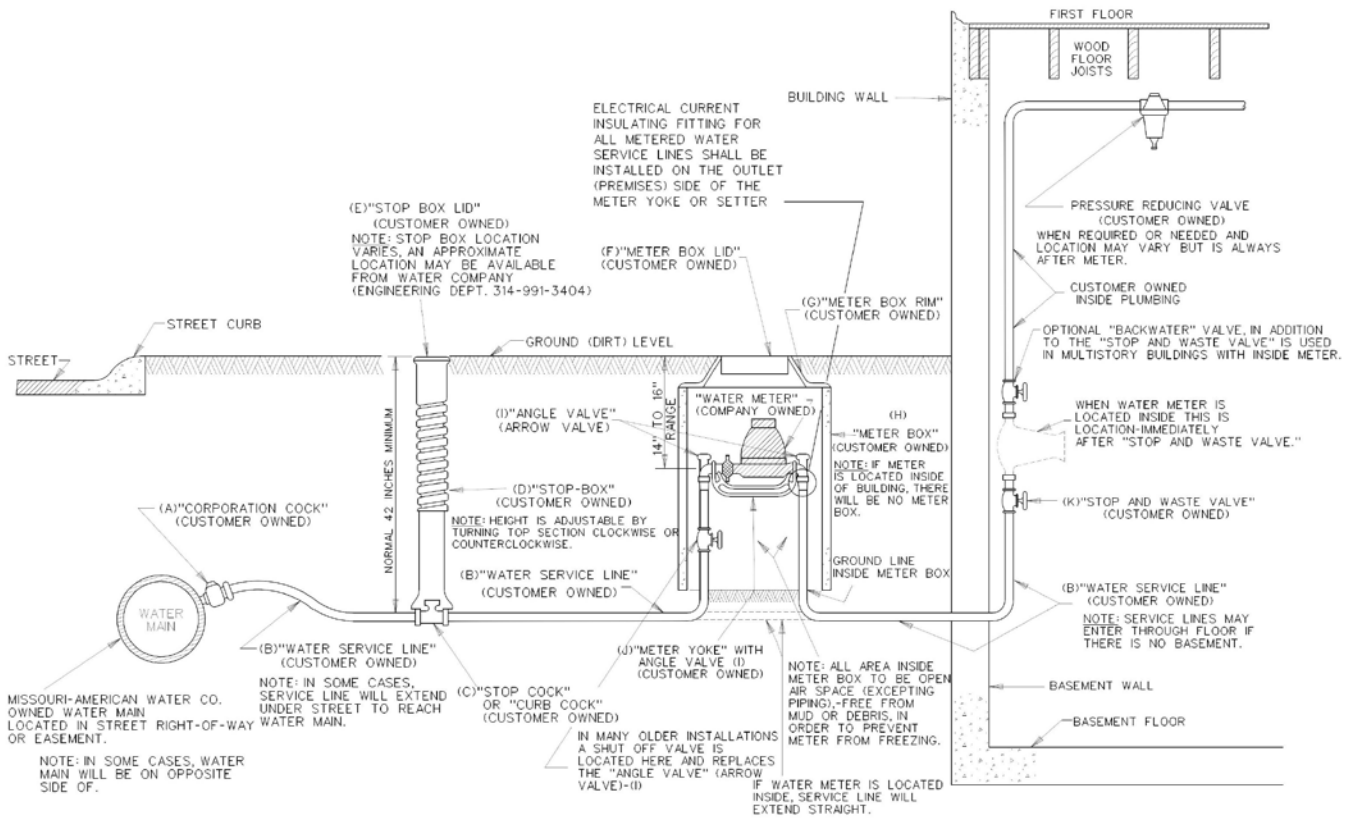

* Indicates new rate or text

+ Indicates change

DATE OF ISSUE: August 26, 2011

DATE OF EFFECTIVE: ~~October 1, 2011~~

October 15, 2011

ISSUED BY: Frank Kartmann, President
727 Craig Road, St. Louis, MO 63141

FILED
Missouri Public
Service Commission
JW-2012-0087

Missouri-American Water Company
Name of Issuing Corporation

For

Missouri Service Area
Community, Town or City

INSTALLATION REQUIREMENT FOR WATER SERVICE LINE – COMPANY MAIN
PARALLEL TO STREET – PARALLEL TO FACE OF PREMISES

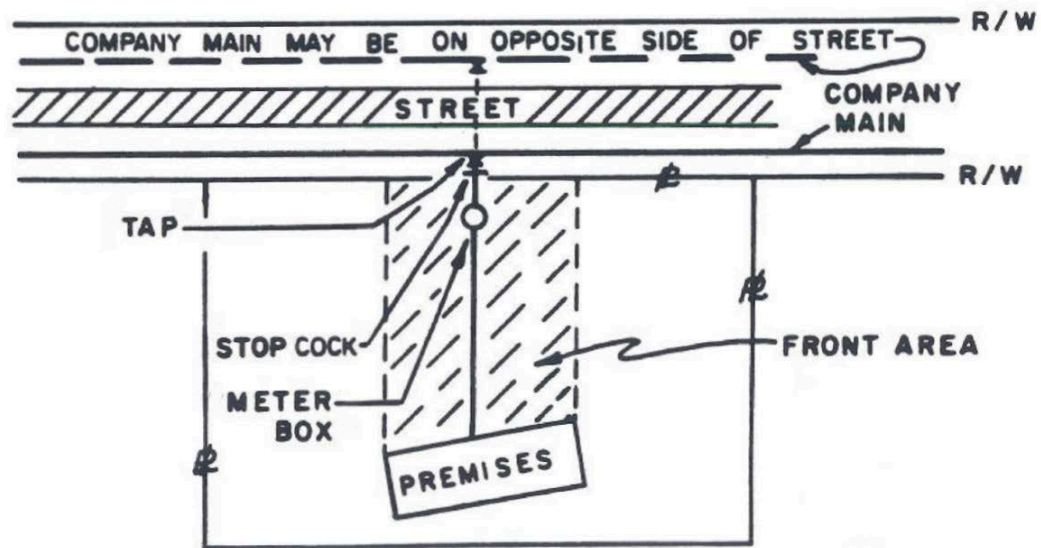
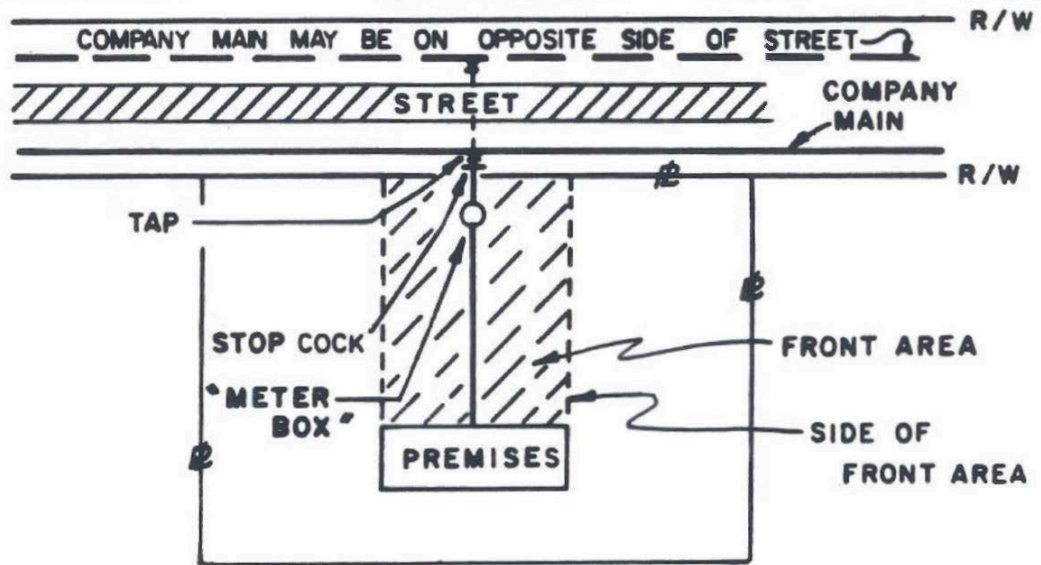

* Indicates new rate or text

+ Indicates change

DATE OF ISSUE: August 26, 2011

DATE OF EFFECTIVE: ~~October 1, 2011~~ **October 15, 2011**

ISSUED BY: Frank Kartmann, President
727 Craig Road, St. Louis, MO 63141

FILED
Missouri Public
Service Commission
JW-2012-0087

Missouri-American Water Company
Name of Issuing Corporation

For

Missouri Service Area
Community, Town or City

INSTALLATION REQUIREMENT FOR WATER SERVICE LINE – COMPANY MAIN
PARALLEL TO STREET – PARALLEL TO FACE OF PREMISES

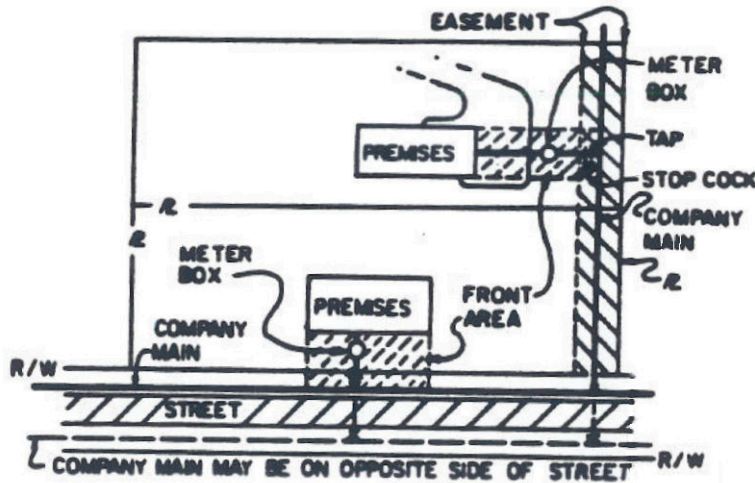
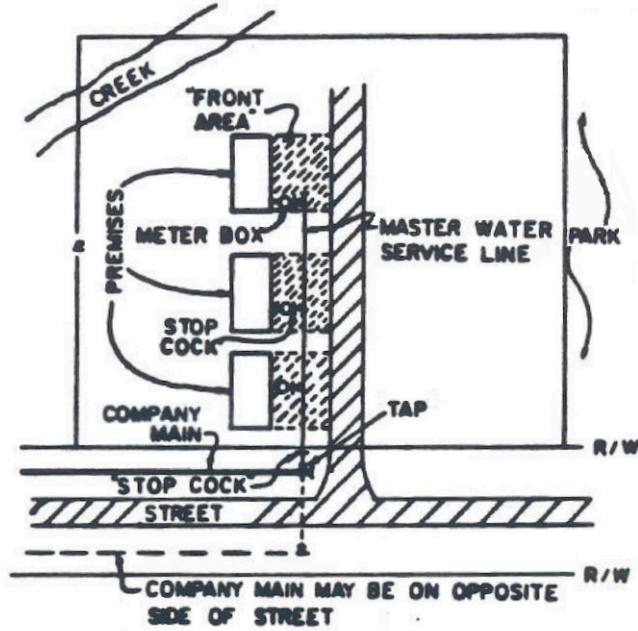

* Indicates new rate or text

+ Indicates change

DATE OF ISSUE: August 26, 2011

DATE OF EFFECTIVE: ~~October 1, 2011~~

October 15, 2011

ISSUED BY: Frank Kartmann, President
727 Craig Road, St. Louis, MO 63141

FILED
Missouri Public
Service Commission
JW-2012-0087

Missouri-American Water Company
Name of Issuing Corporation

For

Missouri Service Area
Community, Town or City

INSTALLATION REQUIREMENTS FOR WATER SERVICE LINE – COMPANY MAIN NOT PARALLEL TO FACE OF PREMISES

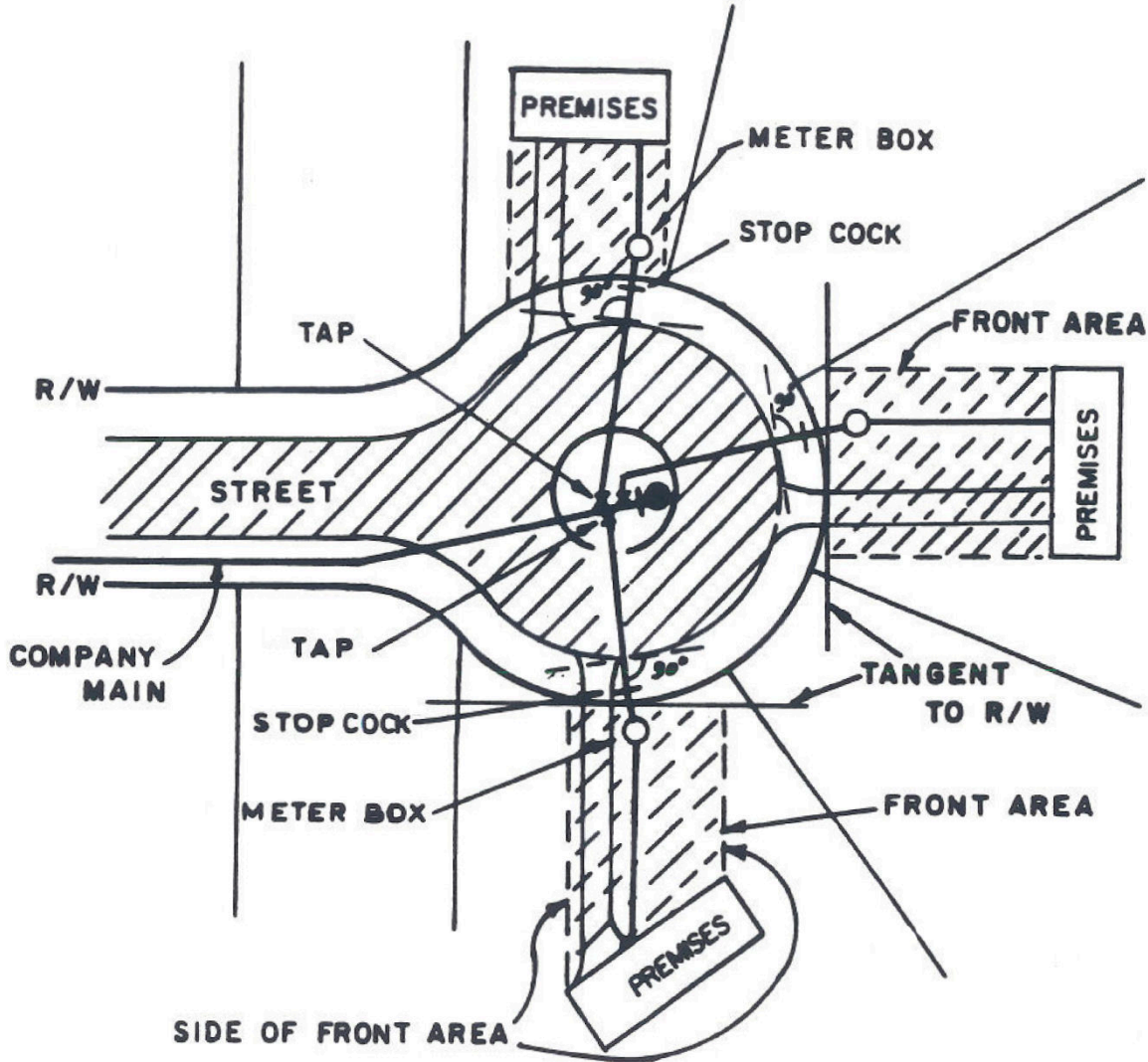

* Indicates new rate or text

+ Indicates change

DATE OF ISSUE: August 26, 2011

DATE OF EFFECTIVE: ~~October 1, 2011~~ **October 15, 2011**

ISSUED BY: Frank Kartmann, President
727 Craig Road, St. Louis, MO 63141

FILED
Missouri Public
Service Commission
JW-2012-0087

Missouri-American Water Company
Name of Issuing Corporation

For

Missouri Service Area
Community, Town or City

INSTALLATION REQUIREMENTS FOR WATER SERVICE LINE – COMPANY MAIN NOT PARALLEL TO STREET – NOT PARALLEL TO FACE OF PREMISES

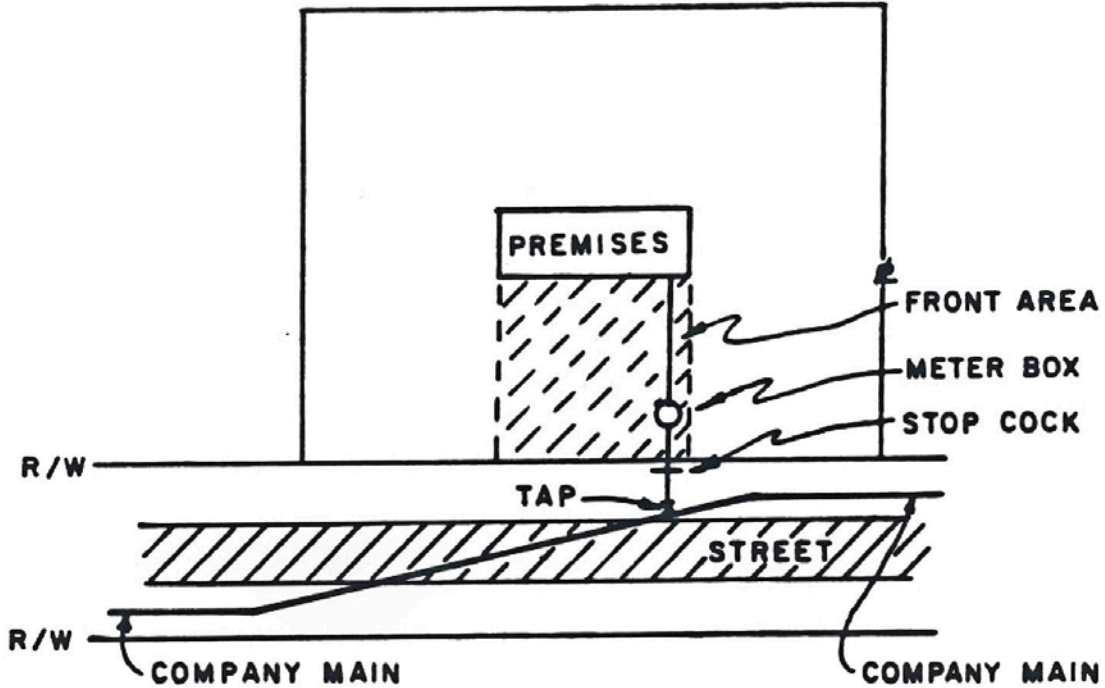

* Indicates new rate or text

+ Indicates change

DATE OF ISSUE: August 26, 2011

DATE OF EFFECTIVE: ~~October 1, 2011~~ **October 15, 2011**

ISSUED BY: Frank Kartmann, President
727 Craig Road, St. Louis, MO 63141

FILED
Missouri Public
Service Commission
JW-2012-0087

Missouri-American Water Company
Name of Issuing Corporation

For

Missouri Service Area
Community, Town or City

**MAIN EXTENSION TERMINATION
NEW STREETS (EASEMENTS) – MULTI-LOT RESIDENTIAL SUBDIVISION – LAST LOT**

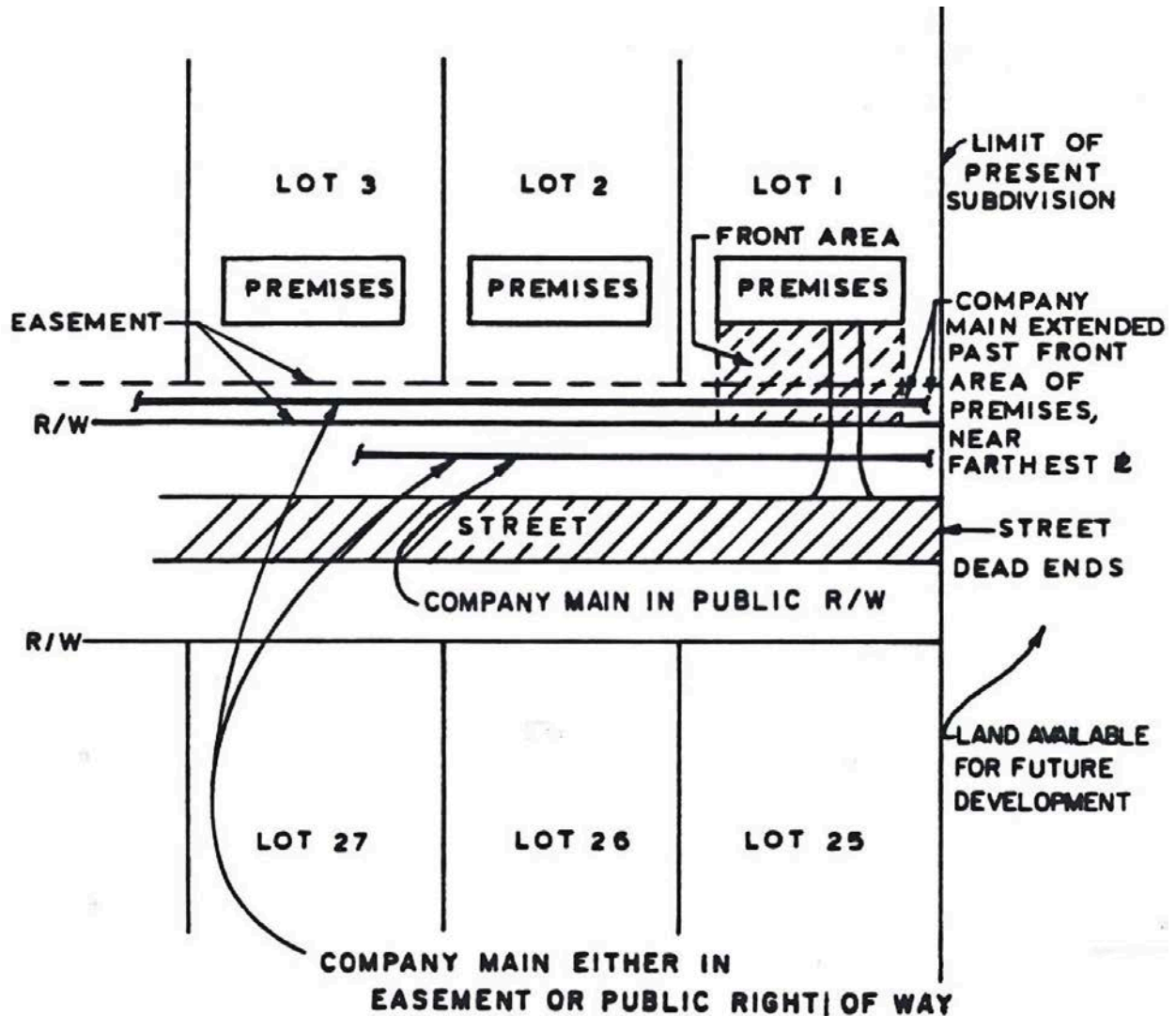

* Indicates new rate or text

+ Indicates change

DATE OF ISSUE: August 26, 2011

DATE OF EFFECTIVE: ~~October 1, 2011~~ **October 15, 2011**

ISSUED BY: Frank Kartmann, President
727 Craig Road, St. Louis, MO 63141

FILED
Missouri Public
Service Commission
JW-2012-0087

Missouri-American Water Company
Name of Issuing Corporation

For

Missouri Service Area
Community, Town or City

**MAIN EXTENSION TERMINATION
EXISTING STREET (EASEMENT) – WATER SERVICE LINE TO INDIVIDUAL PREMISES**

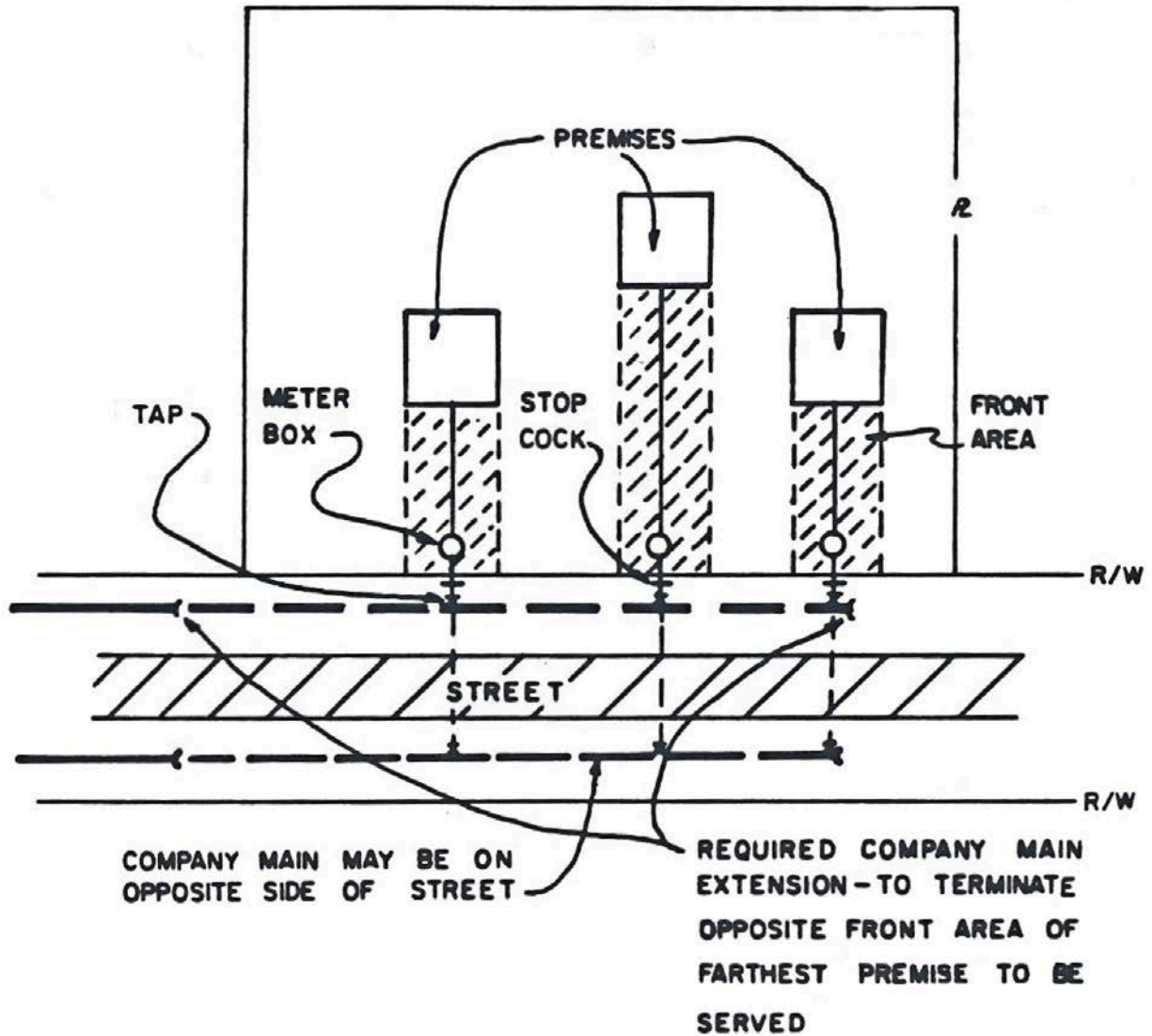

* Indicates new rate or text

+ Indicates change

DATE OF ISSUE: August 26, 2011

DATE OF EFFECTIVE: ~~October 1, 2011~~ **October 15, 2011**

ISSUED BY: Frank Kartmann, President
727 Craig Road, St. Louis, MO 63141

FILED
Missouri Public
Service Commission
JW-2012-0087

Missouri-American Water Company
Name of Issuing Corporation

For

Missouri Service Area
Community, Town or City

INSTALLATION REQUIREMENT – MASTER WATER SERVICE LINE

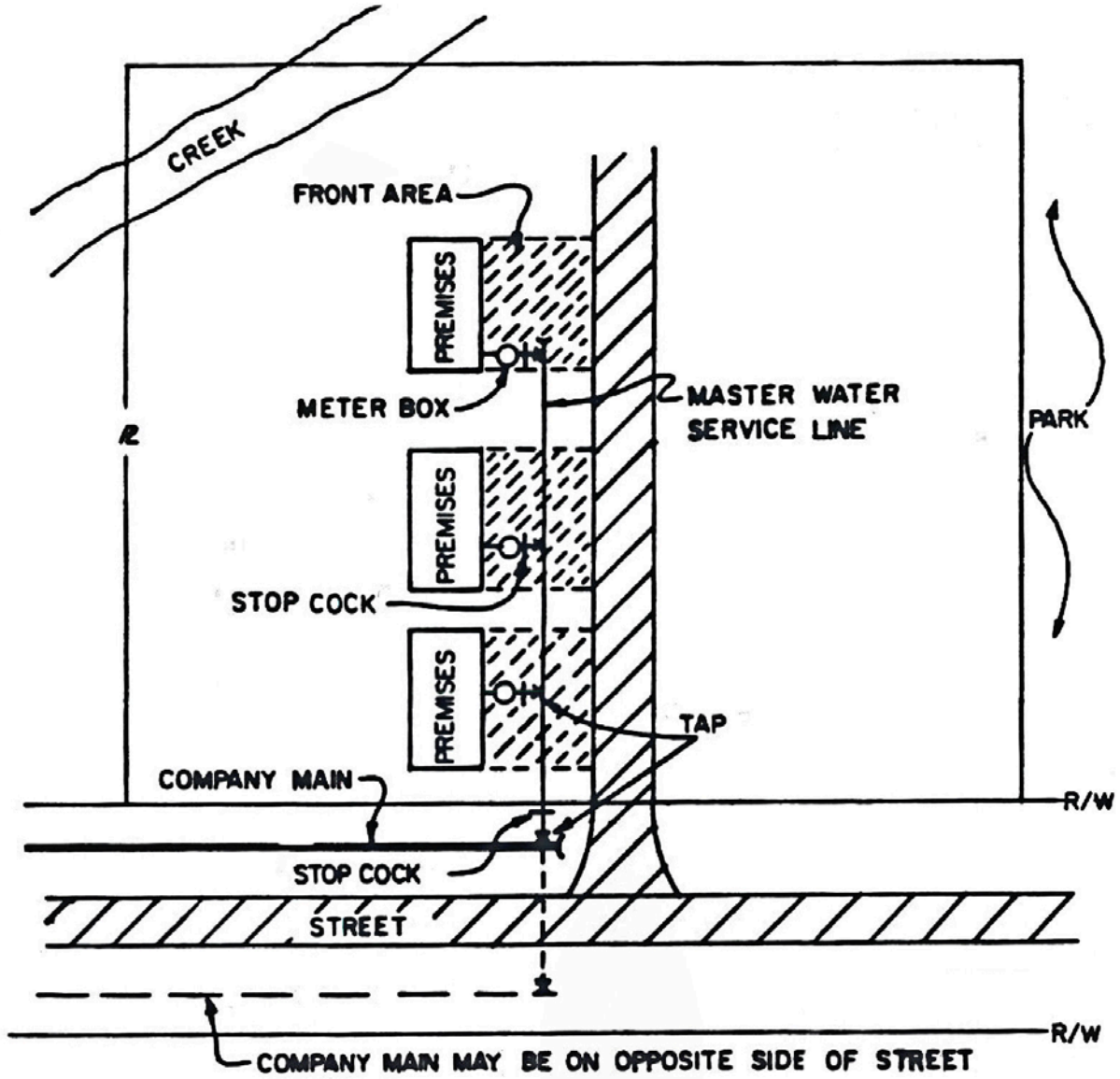

* Indicates new rate or text

+ Indicates change

DATE OF ISSUE: August 26, 2011

DATE OF EFFECTIVE: ~~October 1, 2011~~
October 15, 2011

ISSUED BY: Frank Kartmann, President
727 Craig Road, St. Louis, MO 63141

FILED
Missouri Public
Service Commission
JW-2012-0087

Missouri-American Water Company
Name of Issuing Corporation

For

Missouri Service Area
Community, Town or City

INSTALLATION REQUIREMENT - MASTER WATER SERVICE LINE

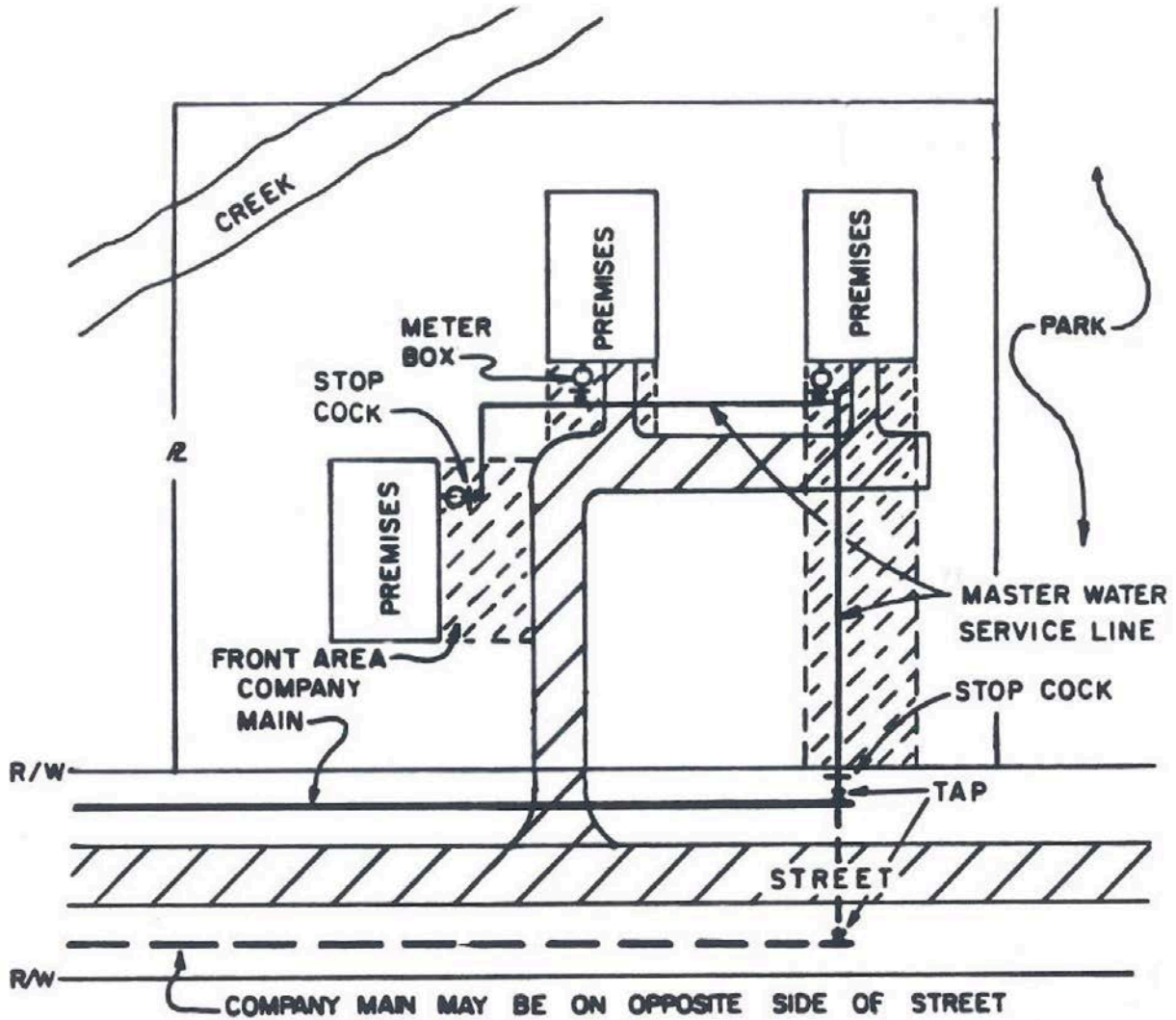

* Indicates new rate or text

+ Indicates change

DATE OF ISSUE: August 26, 2011

DATE OF EFFECTIVE: ~~October 1, 2011~~ **October 15, 2011**

ISSUED BY: Frank Kartmann, President
727 Craig Road, St. Louis, MO 63141

FILED
Missouri Public
Service Commission
JW-2012-0087

Missouri-American Water Company
Name of Issuing Corporation

For

Missouri Service Area
Community, Town or City

**INSTALLATION REQUIREMENTS – MASTER WATER SERVICE LINE
COMMERCIAL OR MUTLI-FAMILY RESIDENTIAL – SINGLE OR MUTLI-STORY BUILDINGS
SERVED BY A METER(S)**

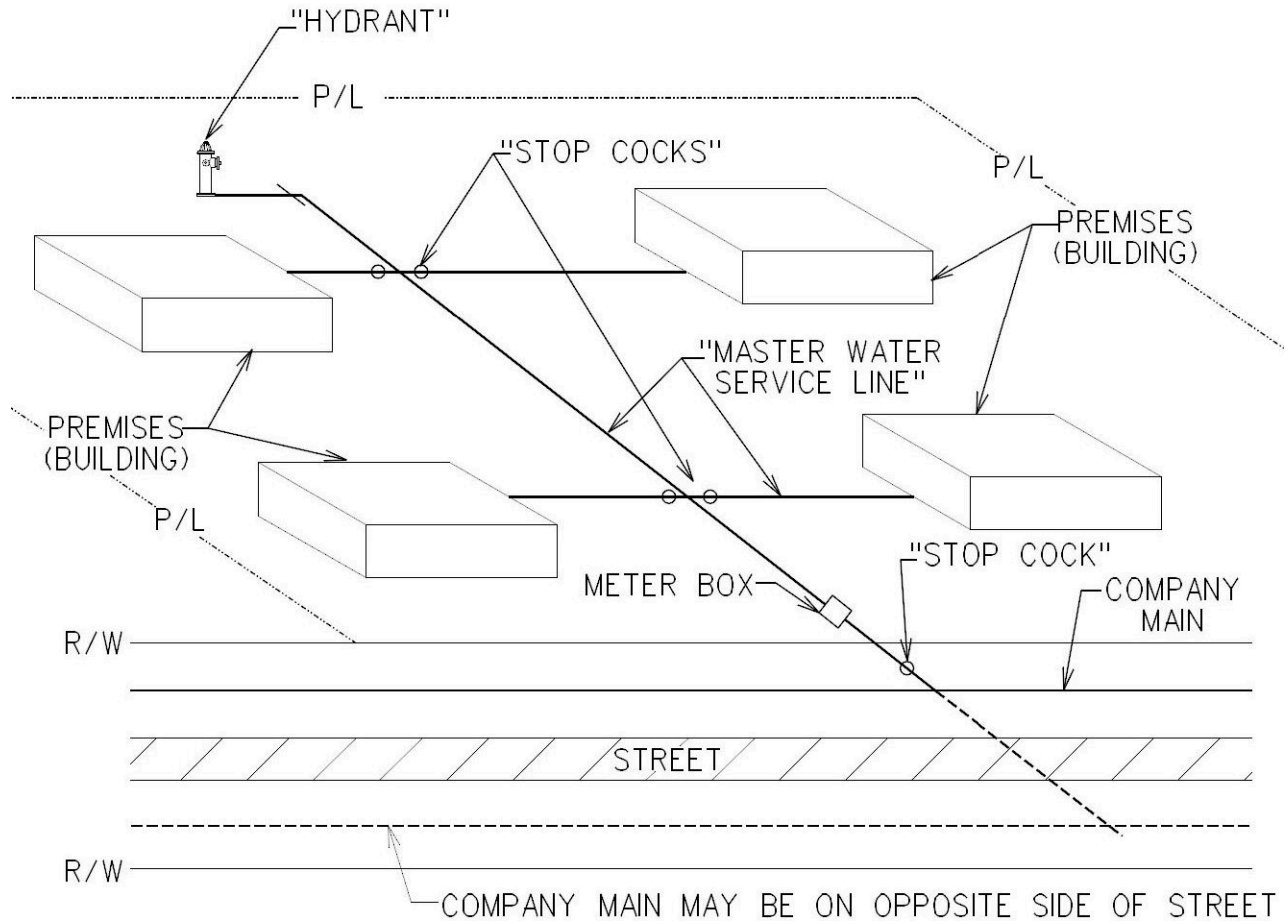

* Indicates new rate or text

+ Indicates change

DATE OF ISSUE: August 26, 2011

DATE OF EFFECTIVE: ~~October 1, 2011~~
October 15, 2011

ISSUED BY: Frank Kartmann, President
727 Craig Road, St. Louis, MO 63141

FILED
Missouri Public
Service Commission
JW-2012-0087

Missouri-American Water Company
Name of Issuing Corporation

For

Missouri Service Area
Community, Town or City

**ALTERNATE INSTALLATION REQUIREMENTS – DOMESTIC WATER SERVICE LINE –
RESIDENTIAL SINGLE-FAMILY DWELLING**

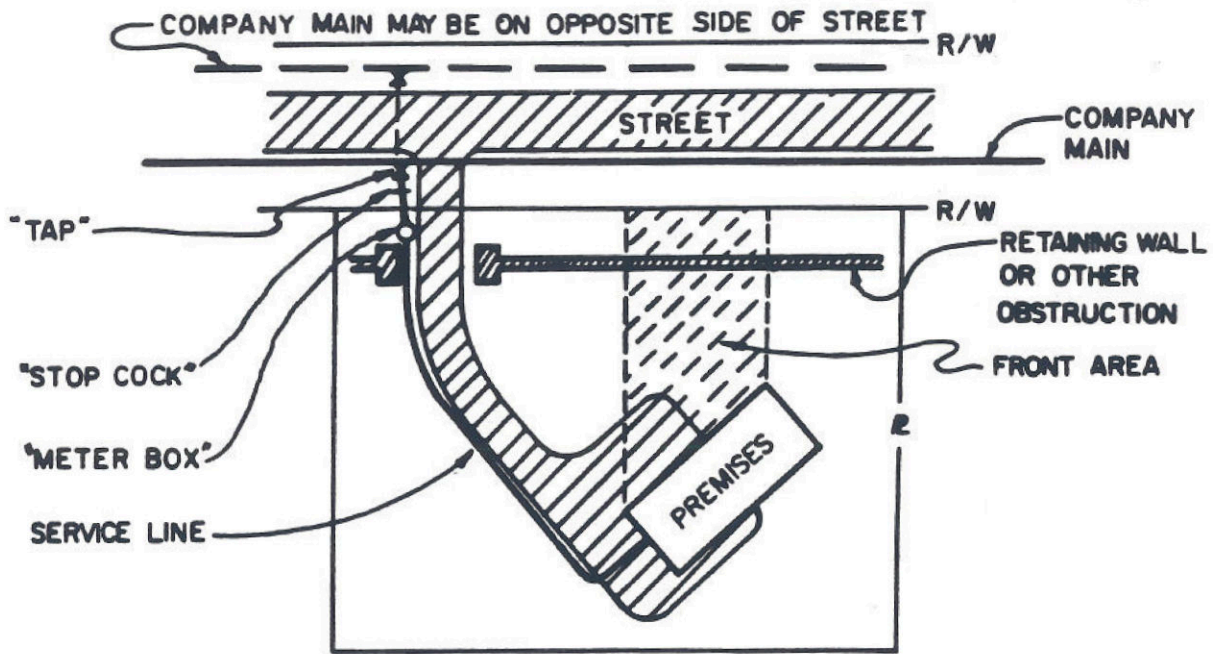

* Indicates new rate or text

+ Indicates change

DATE OF ISSUE: August 26, 2011

DATE OF EFFECTIVE: ~~October 1, 2011~~
October 15, 2011

ISSUED BY: Frank Kartmann, President
727 Craig Road, St. Louis, MO 63141

FILED
Missouri Public
Service Commission
JW-2012-0087

Missouri-American Water Company
Name of Issuing Corporation

For

Missouri Service Area
Community, Town or City

**ALTERNATE INSTALLATION REQUIREMENTS – DOMESTIC WATER SERVICE LINE –
RESIDENTIAL SINGLE-FAMILY DWELLING**

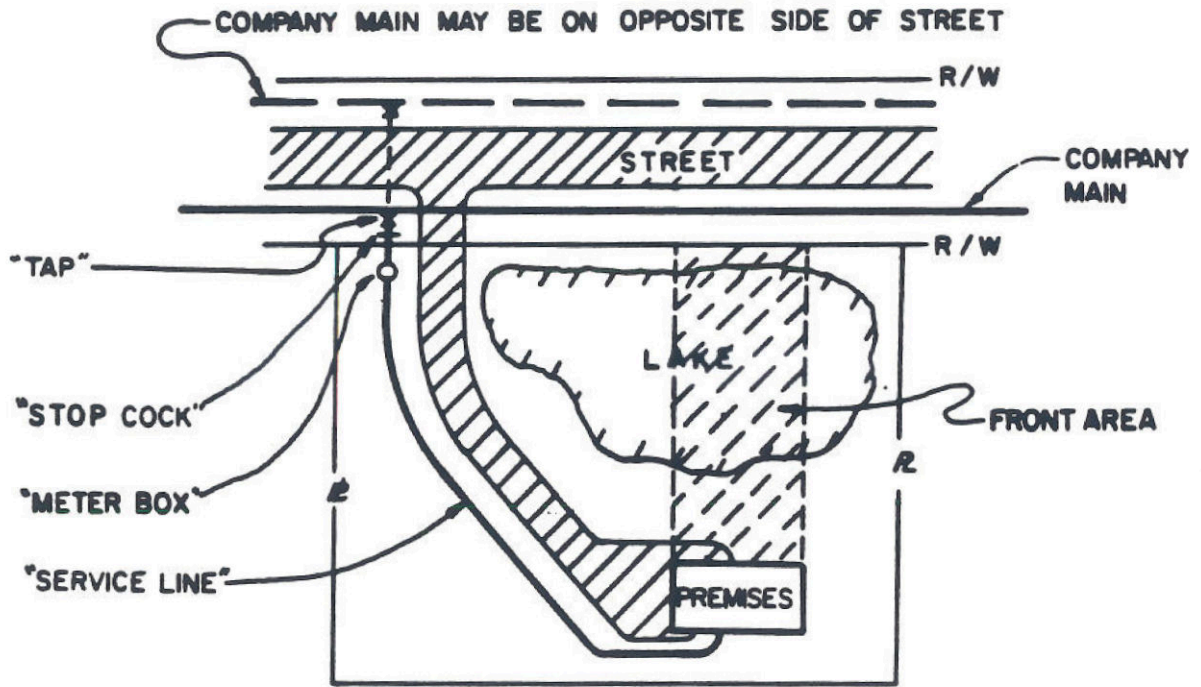

* Indicates new rate or text

+ Indicates change

DATE OF ISSUE: August 26, 2011

DATE OF EFFECTIVE: ~~October 1, 2011~~
October 15, 2011

ISSUED BY: Frank Kartmann, President
727 Craig Road, St. Louis, MO 63141

FILED
Missouri Public
Service Commission
JW-2012-0087

Missouri-American Water Company
Name of Issuing Corporation

For

Missouri Service Area
Community, Town or City

**INSTALLATION REQUIREMENTS – DOMESTIC WATER SERVICE LINE
RESIDENTIAL - DUPLEX – HALVES OWNED OR RENTED**

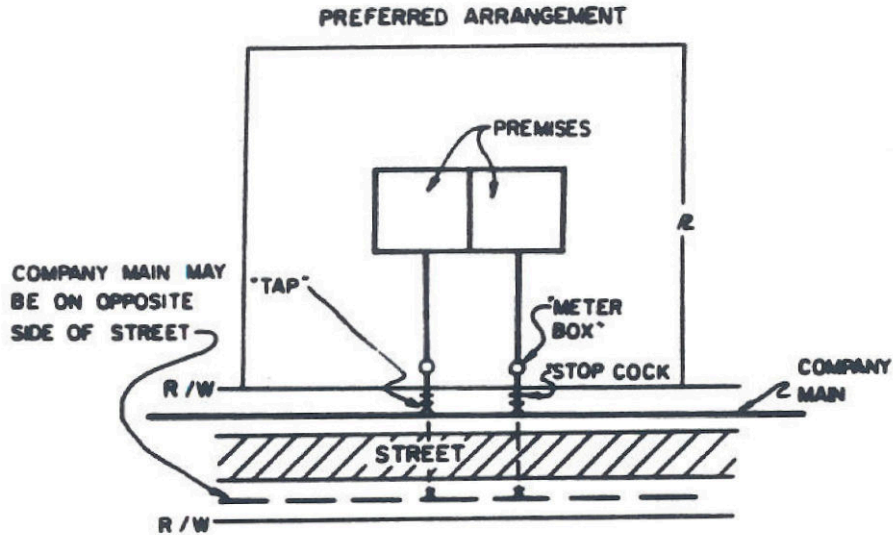

* Indicates new rate or text

+ Indicates change

DATE OF ISSUE: August 26, 2011

DATE OF EFFECTIVE: ~~October 1, 2011~~

October 15, 2011

ISSUED BY: Frank Kartmann, President
727 Craig Road, St. Louis, MO 63141

FILED
Missouri Public
Service Commission
JW-2012-0087

Missouri-American Water Company
Name of Issuing Corporation

For

Missouri Service Area
Community, Town or City

**INSTALLATION REQUIREMENTS – DOMESTIC WATER SERVICE LINE
RESIDENTIAL DUPLEX – HALVES OWNED OR RENTED**

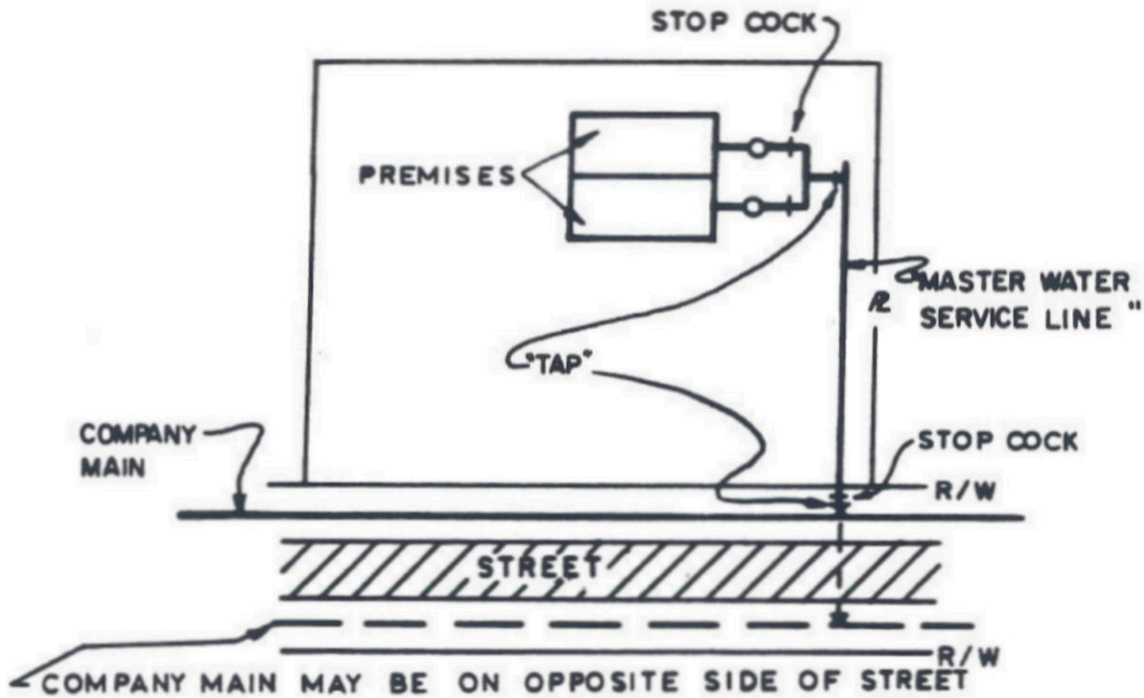

* Indicates new rate or text

+ Indicates change

DATE OF ISSUE: August 26, 2011

DATE OF EFFECTIVE: ~~October 1, 2011~~
October 15, 2011

ISSUED BY: Frank Kartmann, President
727 Craig Road, St. Louis, MO 63141

FILED
Missouri Public
Service Commission
JW-2012-0087

Missouri-American Water Company
Name of Issuing Corporation

For

Missouri Service Area
Community, Town or City

**INSTALLATION REQUIREMENTS – DOMESTIC WATER SERVICE LINE – RESIDENTIAL
MULTI-FAMILY; MULTI-LEVEL BUILDINGS; LIVING QUARTER SEPARATELY OWNED**

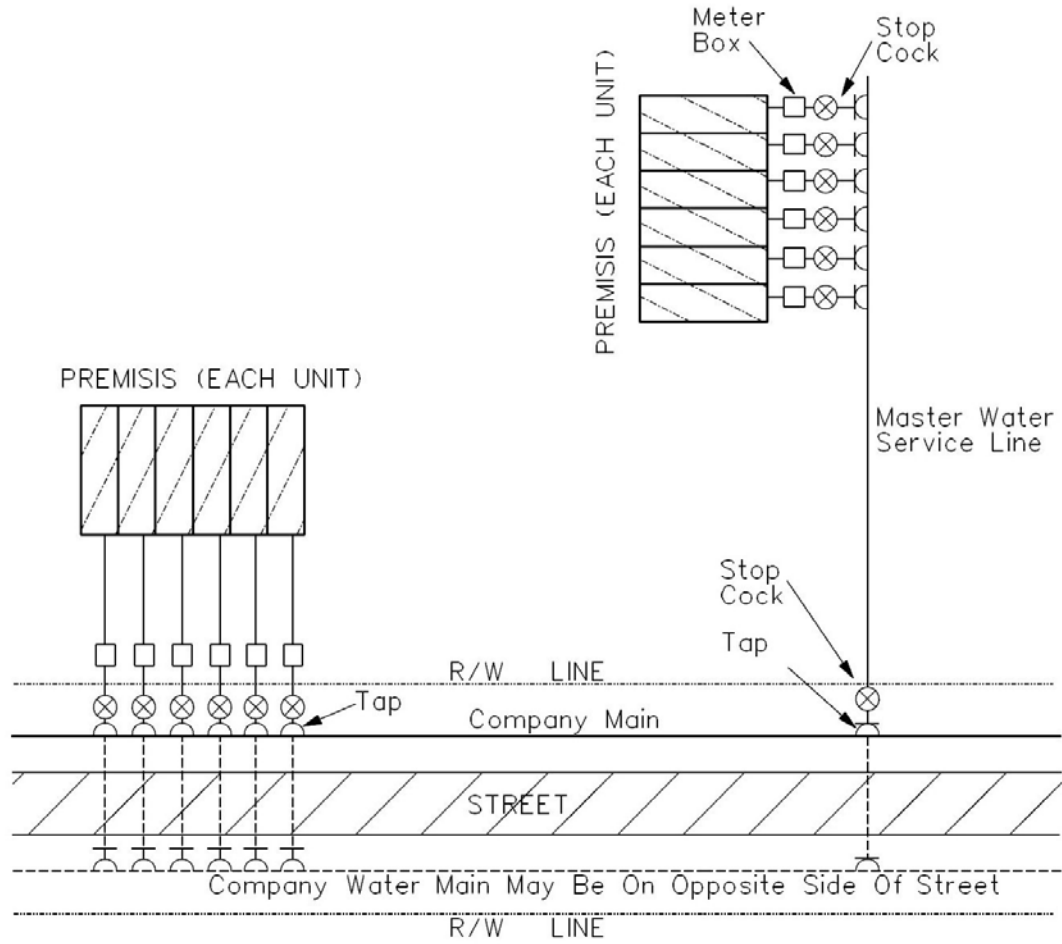

NOTE: If responsibility for payment of water service rests with a single entity, such as a condominium association, then water service to each building could be through one meter.

* Indicates new rate or text

+ Indicates change

DATE OF ISSUE: August 26, 2011

DATE OF EFFECTIVE: ~~October 1, 2011~~
October 15, 2011

ISSUED BY: Frank Kartmann, President
727 Craig Road, St. Louis, MO 63141

FILED
Missouri Public
Service Commission
JW-2012-0087

Missouri-American Water Company
Name of Issuing Corporation

For

Missouri Service Area
Community, Town or City

**INSTALLATION REQUIREMENTS – DOMESTIC WATER SERVICE LINE – RESIDENTIAL
MULTI-FAMILY; MULTI-LEVEL BUILDINGS – LIVING QUARTERS SEPARATELY OWNED**

**ALTERNATE ARRANGEMENT
(IF PROBLEM MAKING MULTIPLE TAPS)**

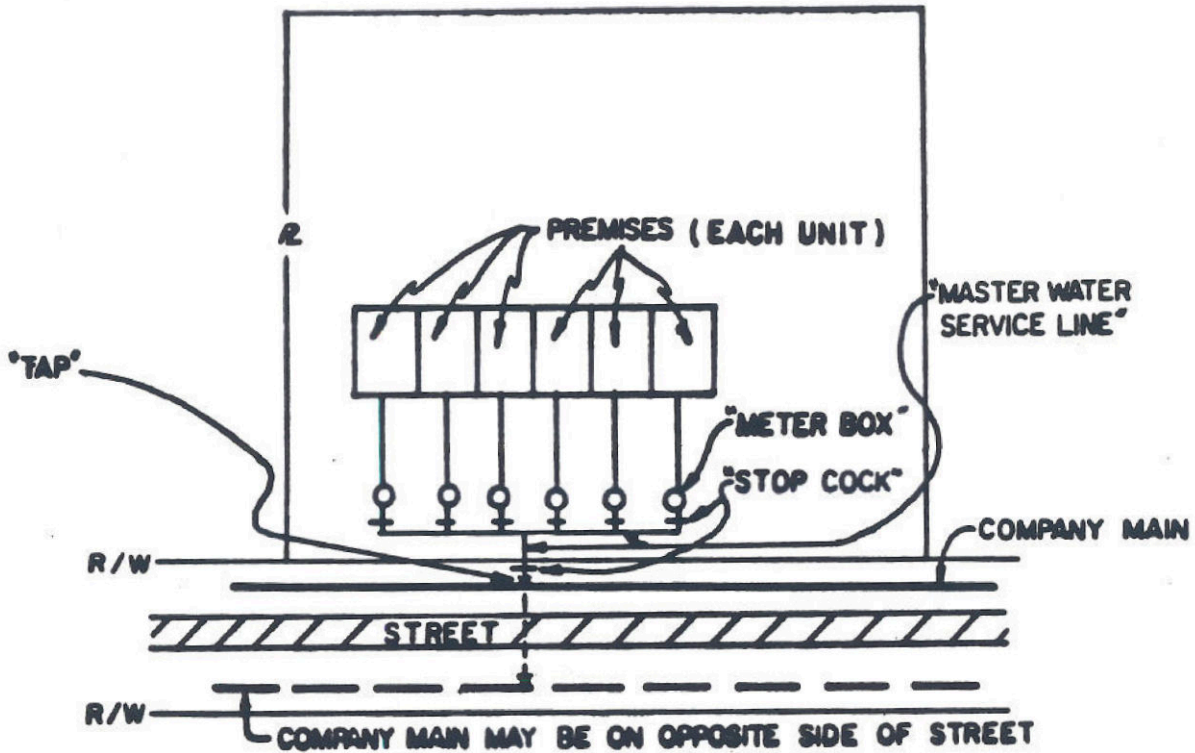

Note: If responsibility for payment of water service rests with a single entity, such as a condominium association, then water service to each building could be through one meter.

* Indicates new rate or text

+ Indicates change

DATE OF ISSUE: August 26, 2011

DATE OF EFFECTIVE: ~~October 1, 2011~~
October 15, 2011

ISSUED BY: Frank Kartmann, President
727 Craig Road, St. Louis, MO 63141

FILED
Missouri Public
Service Commission
JW-2012-0087

Missouri-American Water Company
Name of Issuing Corporation

For

Missouri Service Area
Community, Town or City

**INSTALLATION REQUIREMENTS – DOMESTIC WATER SERVICE LINE – RESIDENTIAL
MULTI-FAMILY; MULTI-LEVEL BUILDINGS – LIVING QUARTERS RENTED**

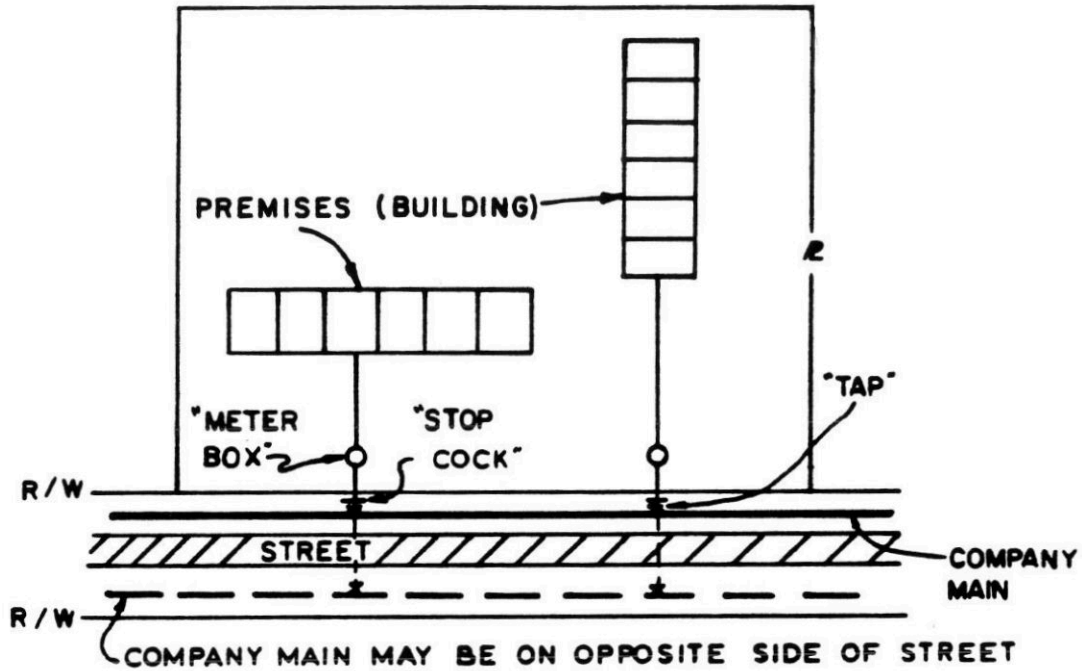

* Indicates new rate or text

+ Indicates change

DATE OF ISSUE: August 26, 2011

October 15, 2011

DATE OF EFFECTIVE: ~~October 1, 2011~~

ISSUED BY: Frank Kartmann, President
727 Craig Road, St. Louis, MO 63141

FILED
Missouri Public
Service Commission
JW-2012-0087

Missouri-American Water Company
Name of Issuing Corporation

For

Missouri Service Area
Community, Town or City

**INSTALLATION REQUIREMENTS – DOMESTIC WATER SERVICE LINE
COMMERCIAL – SINGLE STORY**

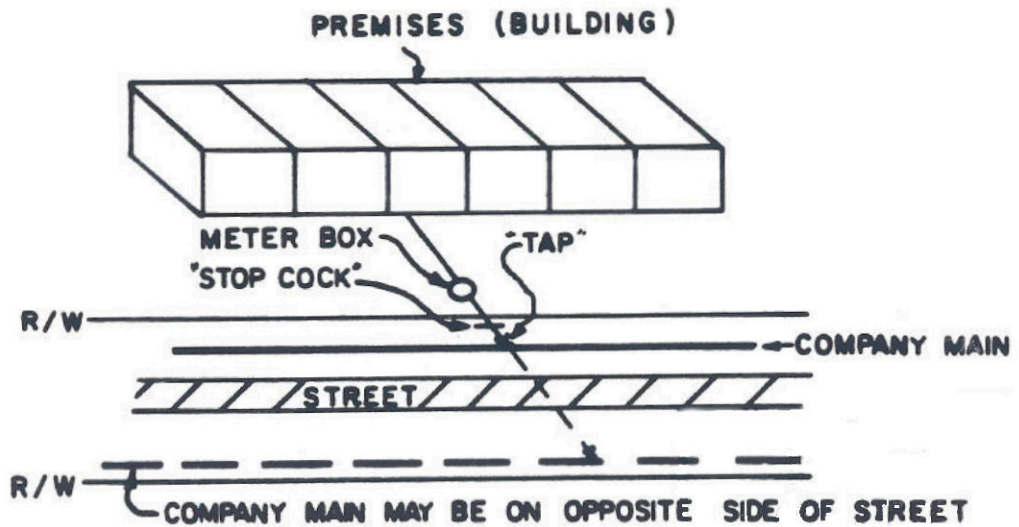
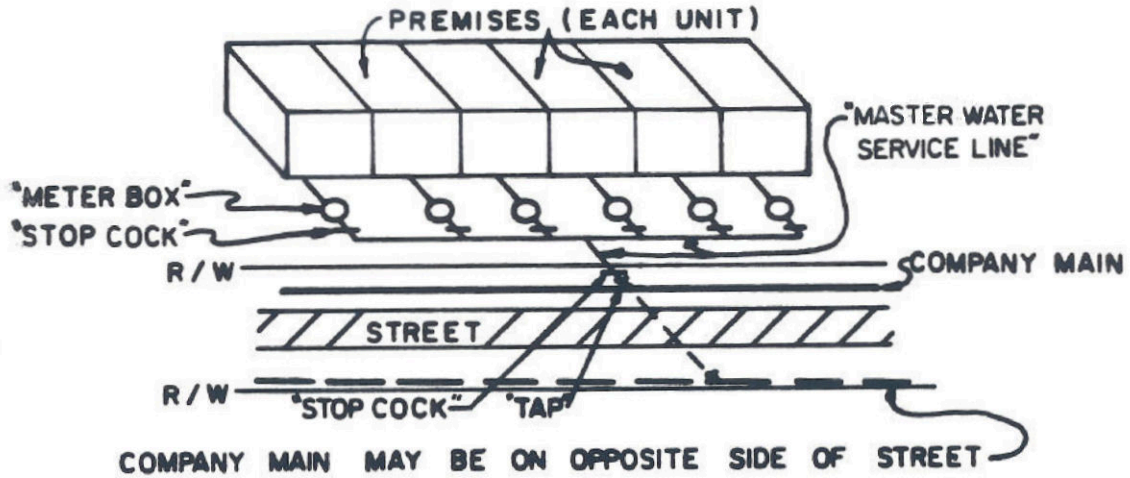

* Indicates new rate or text

+ Indicates change

DATE OF ISSUE: August 26, 2011

DATE OF EFFECTIVE: ~~October 1, 2011~~
October 15, 2011

ISSUED BY: Frank Kartmann, President
727 Craig Road, St. Louis, MO 63141

FILED
Missouri Public
Service Commission
JW-2012-0087

Missouri-American Water Company
Name of Issuing Corporation

For

Missouri Service Area
Community, Town or City

**INSTALLATION REQUIREMENTS – DOMESTIC WATER SERVICE
COMMERCIAL – MULTI-STORY BUILDING**

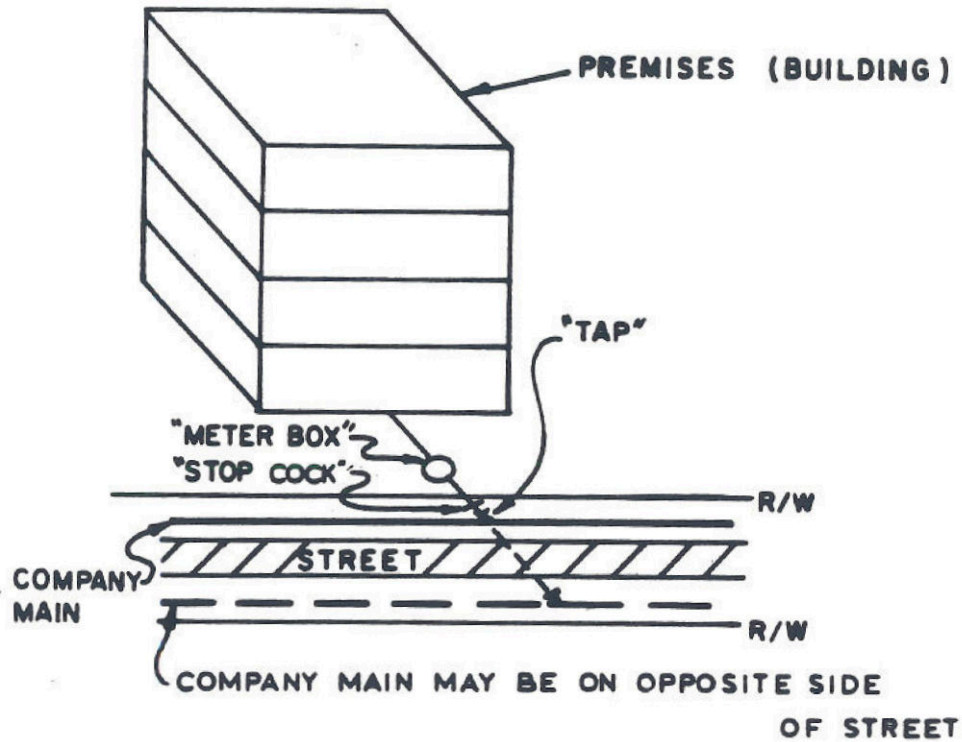

* Indicates new rate or text

+ Indicates change

DATE OF ISSUE: August 26, 2011

DATE OF EFFECTIVE: ~~October 1, 2011~~
October 15, 2011

ISSUED BY: Frank Kartmann, President
727 Craig Road, St. Louis, MO 63141

FILED
Missouri Public
Service Commission
JW-2012-0087

Missouri-American Water Company
Name of Issuing Corporation

For

Missouri Service Area
Community, Town or City

**INSTALLATION REQUIREMENTS – DOMESTIC WATER SERVICE
COMMERCIAL – MULTI-STORY BUILDING**

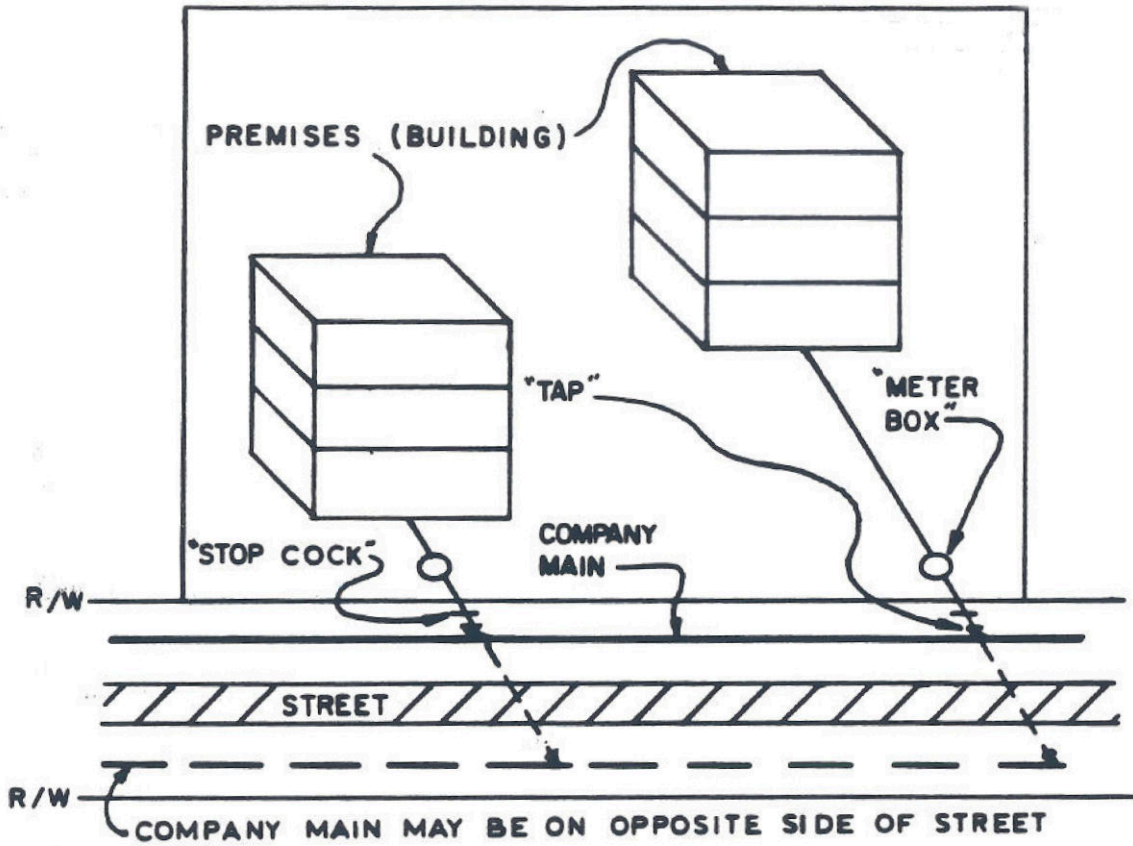

* Indicates new rate or text

+ Indicates change

DATE OF ISSUE: August 26, 2011

DATE OF EFFECTIVE: ~~October 1, 2011~~ **October 15, 2011**

ISSUED BY: Frank Kartmann, President
727 Craig Road, St. Louis, MO 63141

FILED
Missouri Public
Service Commission
JW-2012-0087

Missouri-American Water Company
Name of Issuing Corporation

For

Missouri Service Area
Community, Town or City

**INSTALLATION REQUIREMENTS – DOMESTIC WATER SERVICE LINE
COMMERCIAL – MULTI-STORY BUILDING**

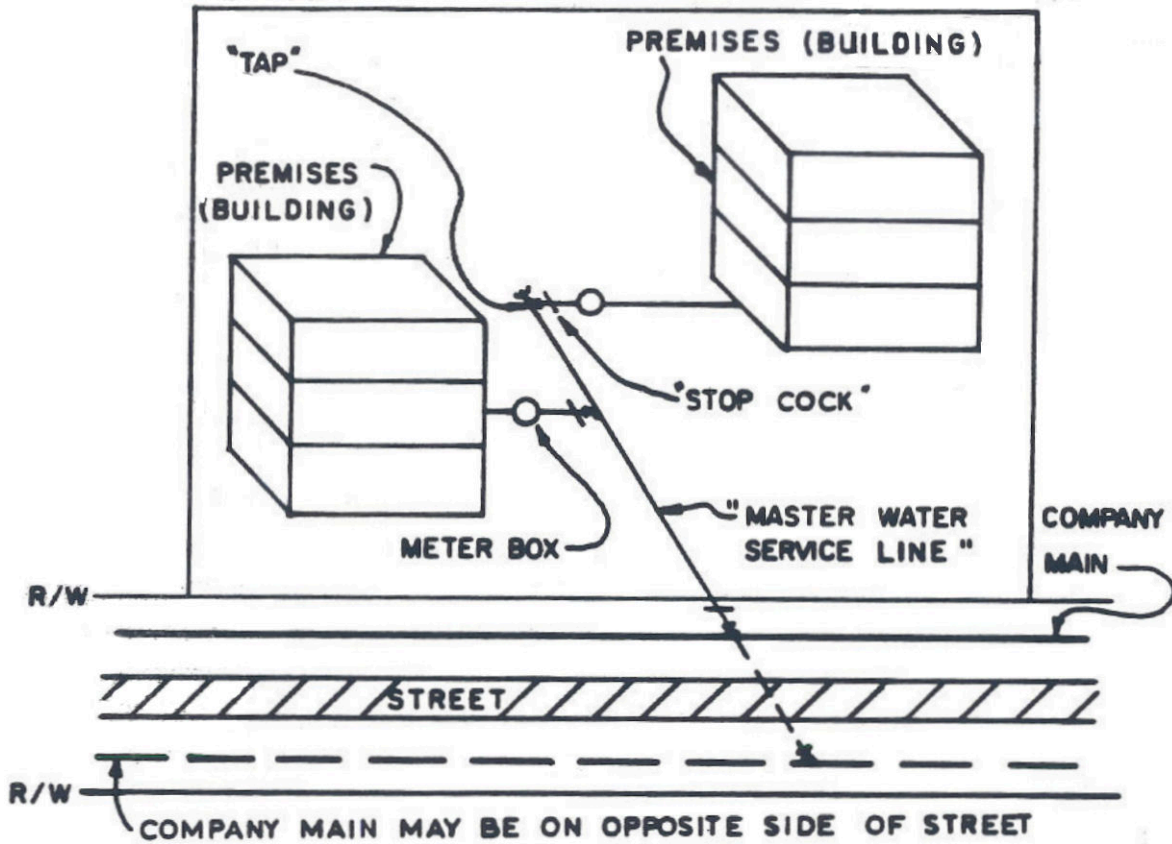

* Indicates new rate or text

+ Indicates change

DATE OF ISSUE: August 26, 2011

DATE OF EFFECTIVE: ~~October 1, 2011~~
October 15, 2011

ISSUED BY: Frank Kartmann, President
727 Craig Road, St. Louis, MO 63141

FILED
Missouri Public
Service Commission
JW-2012-0087

Missouri-American Water Company
Name of Issuing Corporation

For

Missouri Service Area
Community, Town or City

FACE OF A PREMISES

The "Face of a Premises" is the side of the premises nearest parallel to an existing Company main, or an extension thereof. In the case of a cul-de-sac (except as shown on Sheet 23), the "Face of a Premises" is the side of the premises nearest parallel to the straight line connecting the two front property corners of the property (nearest the street) upon which the premises is located.

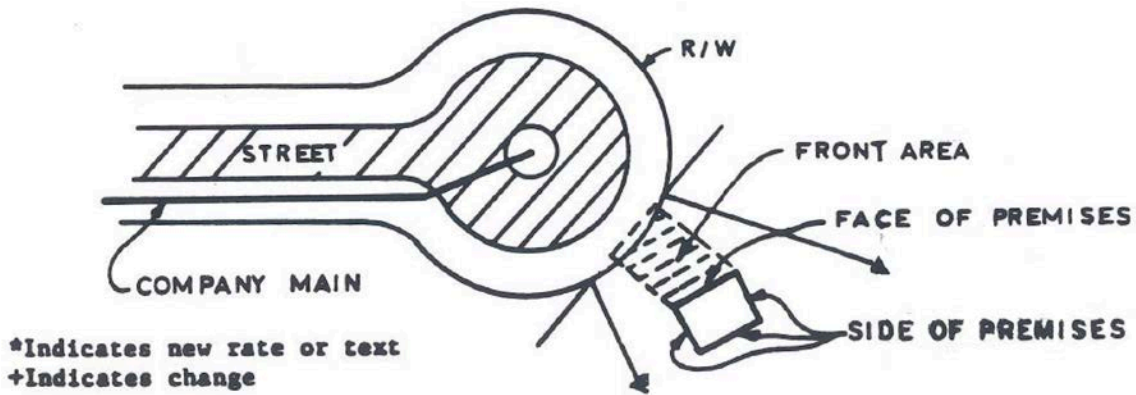
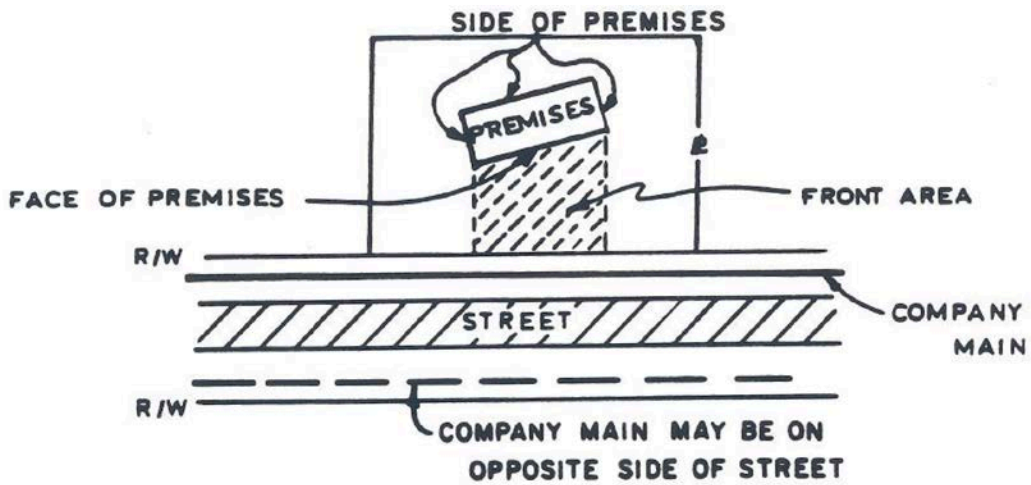

* Indicates new rate or text

+ Indicates change

DATE OF ISSUE: August 26, 2011

DATE OF EFFECTIVE: ~~October 1, 2011~~
October 15, 2011

ISSUED BY: Frank Kartmann, President
727 Craig Road, St. Louis, MO 63141

FILED
Missouri Public
Service Commission
JW-2012-0087

Missouri-American Water Company
Name of Issuing Corporation

For

Missouri Service Area
Community, Town or City

FACE OF A PREMISES (Continued)

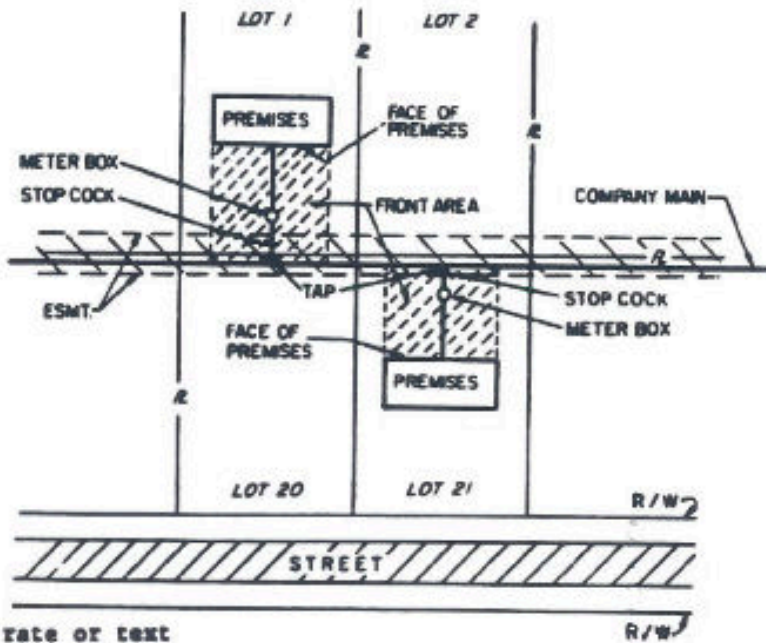
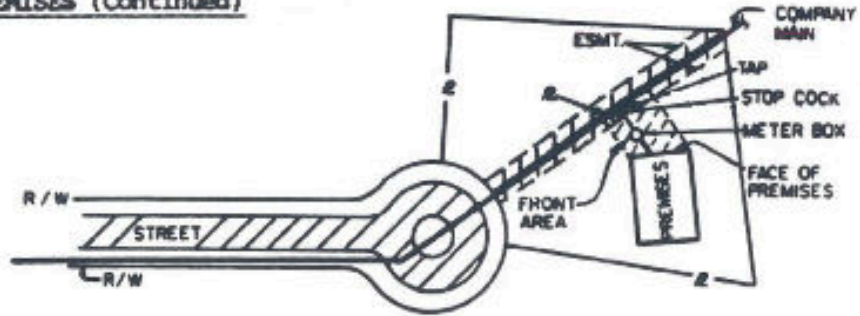

*Indicates new rate or text
+Indicates change

* Indicates new rate or text

+ Indicates change

DATE OF ISSUE: August 26, 2011

DATE OF EFFECTIVE: ~~October 1, 2011~~

October 15, 2011

ISSUED BY: Frank Kartmann, President
727 Craig Road, St. Louis, MO 63141

FILED
Missouri Public
Service Commission
JW-2012-0087

Missouri-American Water Company
Name of Issuing Corporation

For

Missouri Service Area
Community, Town or City

SIDE OF A PREMISES

The "Side of a Premises" is any side of a premises other than the "Face" of the same premises. (See sketch below.)

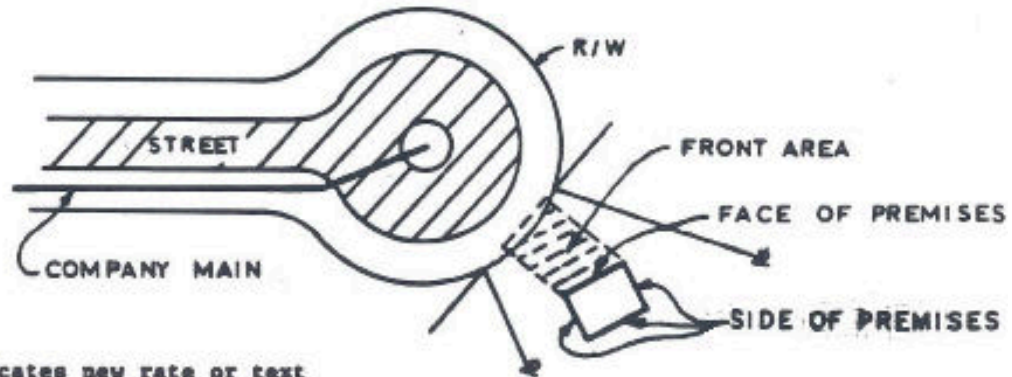
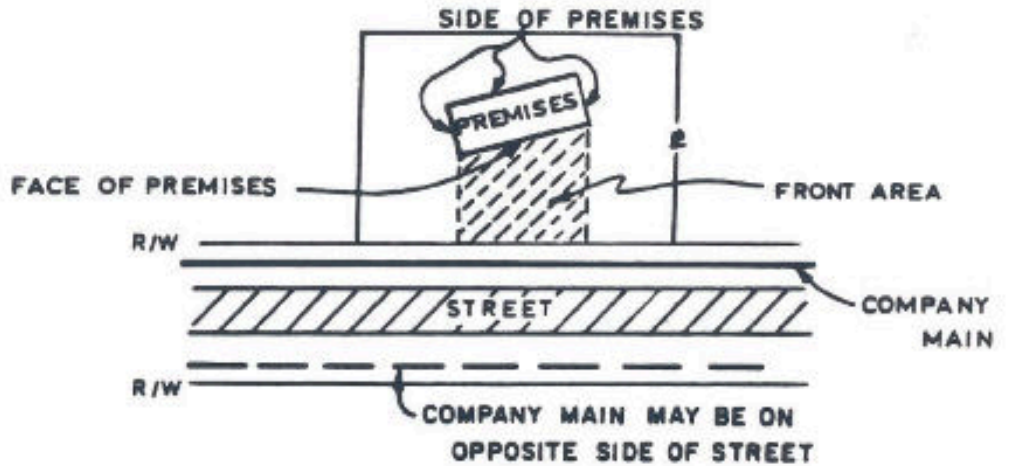

*Indicates new rate or text
+Indicates change

* Indicates new rate or text

+ Indicates change

DATE OF ISSUE: August 26, 2011

DATE OF EFFECTIVE: ~~October 1, 2011~~
October 15, 2011

ISSUED BY: Frank Kartmann, President
727 Craig Road, St. Louis, MO 63141

FILED
Missouri Public
Service Commission
JW-2012-0087

Missouri-American Water Company
Name of Issuing Corporation

For

Missouri Service Area
Community, Town or City

DOMESTIC SERVICE & FIRE SUPPRESSION
UTILIZING COMBINATION SERVICE LINE AND
"FIRE FLOW METER" FOR SERVICES OTHER
THAN ONE OR TWO FAMILY
DWELLINGS UTILIZING COMBINATION
SERVICE LINE/RESIDENTIAL

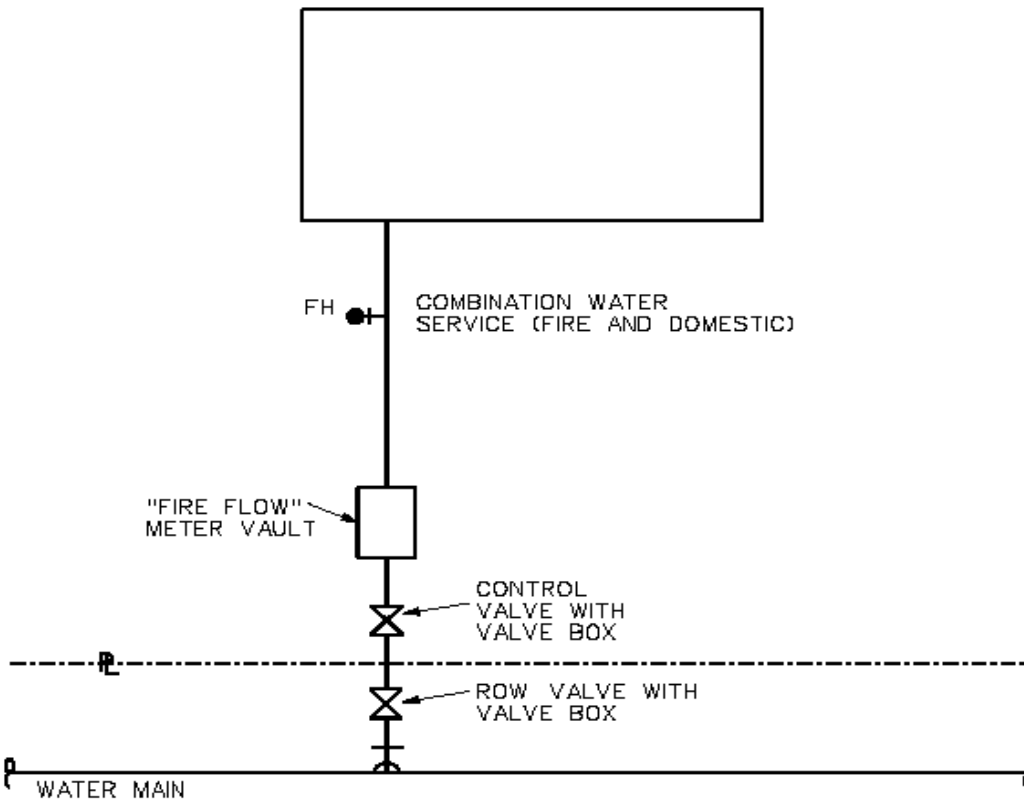

* Indicates new rate or text

+ Indicates change

DATE OF ISSUE: August 26, 2011

DATE OF EFFECTIVE: ~~October 1, 2011~~
October 15, 2011

ISSUED BY: Frank Kartmann, President
727 Craig Road, St. Louis, MO 63141

FILED
Missouri Public
Service Commission
JW-2012-0087

Missouri-American Water Company
Name of Issuing Corporation

For

Missouri Service Area
Community, Town or City

DOMESTIC SERVICE &
FIRE SUPPRESSION FOR
ONE OR TWO FAMILY DWELLINGS
UTILIZING COMBINATION
SERVICE LINE/RESIDENTIAL

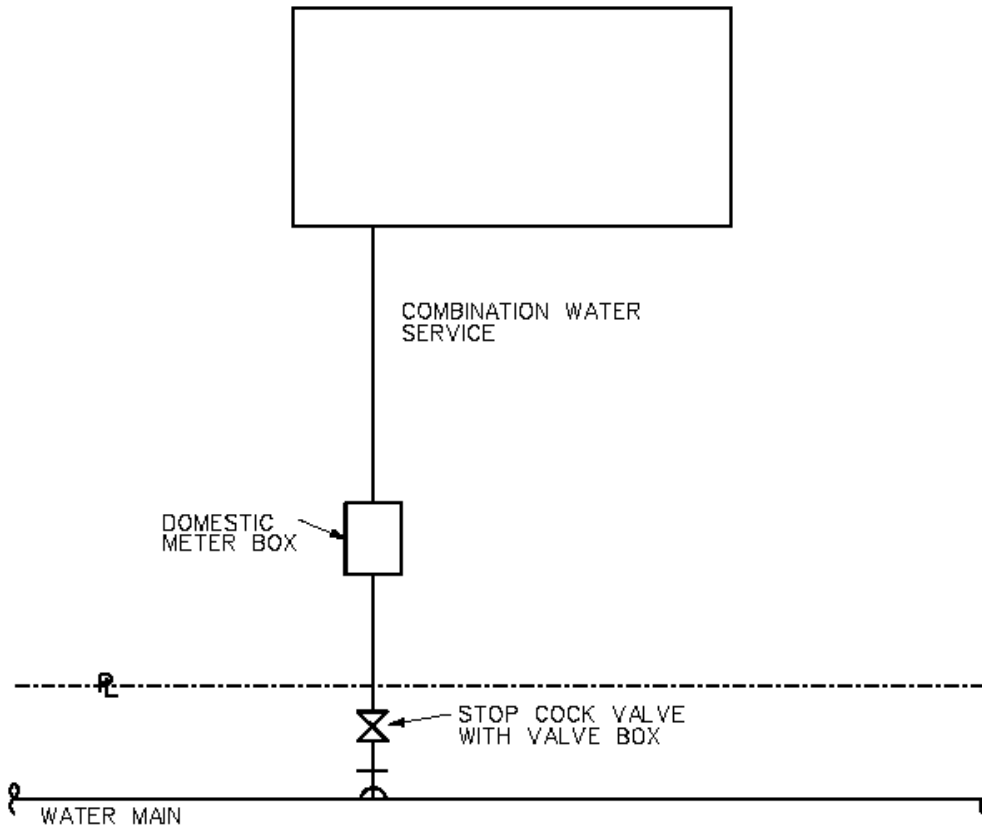

* Indicates new rate or text

+ Indicates change

DATE OF ISSUE: August 26, 2011

DATE OF EFFECTIVE: ~~October 1, 2011~~
October 15, 2011

ISSUED BY: Frank Kartmann, President
727 Craig Road, St. Louis, MO 63141

FILED
Missouri Public
Service Commission
JW-2012-0087

Missouri-American Water Company
Name of Issuing Corporation

For

Missouri Service Area
Community, Town or City

FIRE SERVICE & SEPARATE DOMESTIC SERVICE

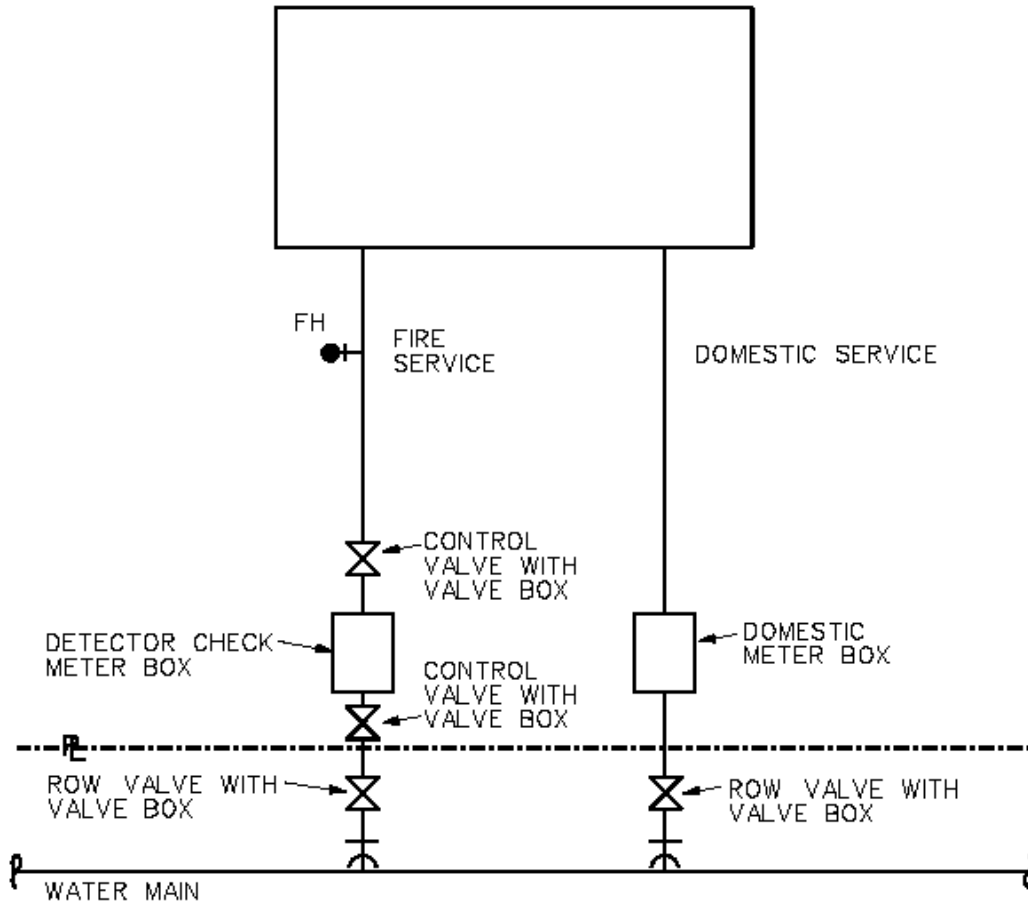

* Indicates new rate or text

+ Indicates change

DATE OF ISSUE: August 26, 2011

DATE OF EFFECTIVE: ~~October 1, 2011~~
October 15, 2011

ISSUED BY: Frank Kartmann, President
727 Craig Road, St. Louis, MO 63141

FILED
Missouri Public
Service Commission
JW-2012-0087

Missouri-American Water Company
Name of Issuing Corporation

For

Missouri Service Area
Community, Town or City

SPLIT SERVICE WITH (2) METER BOXES

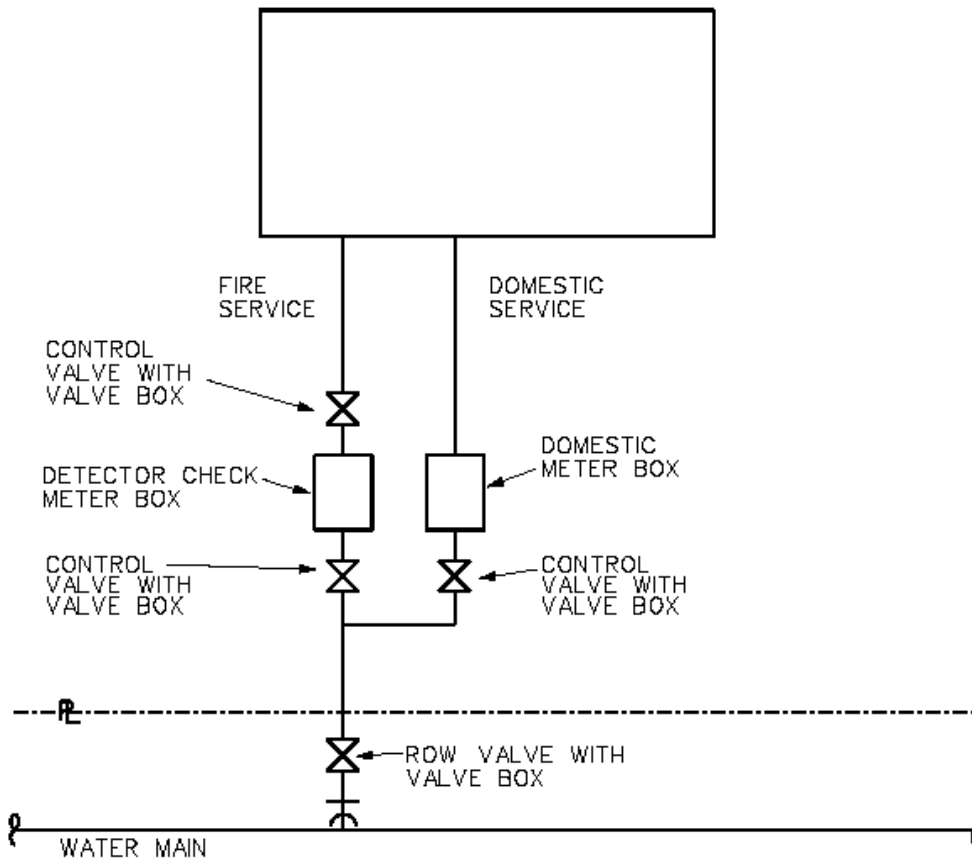

* Indicates new rate or text

+ Indicates change

DATE OF ISSUE: August 26, 2011

DATE OF EFFECTIVE: ~~October 1, 2011~~
October 15, 2011

ISSUED BY: Frank Kartmann, President
727 Craig Road, St. Louis, MO 63141

FILED
Missouri Public
Service Commission
JW-2012-0087