

PRIVATE LINE SERVICE

TABLE OF CONTENTS

	Page
6.1 Link Services .....	1
6.1.1 General .....	1
6.1.2 Regulations .....	2
6.1.3 Term Discount Plan (TDP) .....	13
6.1.4 Termination Liability Charges .....	14
6.1.5 Rate Categories .....	15
6.1.6 Application of Rates .....	23
6.1.7 Rates and Charges .....	27

ISSUED:  
December 10, 2003

BY: Richard D. Lawson  
State Executive, External Affairs  
319 Madison  
Jefferson City, MO 65101

EFFECTIVE:  
January 10, 2004

CANCELLED  
October 19, 2009  
Missouri Public  
Service Commission  
TN-2010-0086; JI-2010-0157

**FILED**  
**MO PSC**

PRIVATE LINE SERVICE

6.1 Link Services

6.1.1 General

- A. Digilink, Translink, and Lightlink Services are furnished for Private Line IntraLATA Intraexchange and Interexchange communications by the Telephone Company.
- B. Digilink, Translink, and Lightlink Services are for the transmission of digital signals and uses digital transmission facilities.
- C. Digilink Service provides for the simultaneous two-way transmission of synchronous digital signals at speeds of **56.0 Kbps** and 64.0 Kbps, where facilities exist. (C)  
  
Translink Service provides for the simultaneous two-way transmission of isochronous digital signals at speeds of **1.544 Mbps** (DS1), where facilities exist. (C)  
  
Lightlink Service provides for the simultaneous two-way transmission of isochronous digital signals at a speed of 44.736 Mbps (DS3), where facilities exist.
- D. To ensure satisfactory operation, the terminal equipment provided by the customer must be compatible with the Digilink, Translink, and Lightlink Service channel facility provided by the Telephone Company.
- E. Unless specified following, the regulations for Digilink, Translink, and Lightlink Services specified herein apply in addition to the regulations set forth in other sections of this tariff.
- F. The rates specified for Digilink, Translink, and Lightlink Services in 6.1.7 following contemplate the provision of a digital quality facility utilizing existing interoffice carrier equipment and/or exchange cable facilities compatible with this service. If equipment, new facilities or changes to existing facilities are required for the provision of this service, then charges as specified in Section 8 of the P.S.C. MO. No. 22 General Exchange Tariff, Construction and Installation Charges will apply in addition to the rates for Digilink, Translink, and Lightlink Services.
- G. Temporary Suspension of Service (Vacation Service) as defined in Section 24 of the P.S.C. MO. No. 22 General Exchange Tariff, is not allowed.
- H. The minimum period for which Digilink and Translink Services are furnished and for which charges are applicable is six (6) months. The minimum period for Lightlink Service is twelve (12) months.

ISSUED:  
January 20, 2009

BY: Darlene N. Terry  
Manager - Tariffs  
5454 W. 110th Street  
Overland Park, Kansas 66211

EFFECTIVE:  
February 1, 2009

PRIVATE LINE SERVICE

6.1 Link Services

6.1.1 General

- A. **Digilink, Translink, and Lightlink** Services are furnished for Private Line IntraLATA (T)  
Intraexchange and Interexchange communications by the Telephone Company.
- B. Digilink, Translink, and Lightlink Services are for the transmission of digital signals  
and uses digital transmission facilities.
- C. Digilink Service provides for the simultaneous two-way transmission of synchronous  
digital signals at speeds of 19.2 Kbps, 56.0 Kbps, and 64.0 Kbps, where facilities  
exist.
- Translink Service provides for the simultaneous two-way transmission of  
isochronous digital signals at speeds of 128 Kbps, 256 Kbps, 384 Kbps, 512 Kbps,  
and 1.544 Mbps (DS1), where facilities exist.
- Lightlink Service provides for the simultaneous two-way transmission of isochronous  
digital signals at a speed of 44.736 Mbps (DS3), where facilities exist.
- D. To ensure satisfactory operation, the terminal equipment provided by the customer  
must be compatible with the Digilink, Translink, and Lightlink Service channel facility  
provided by the Telephone Company.
- E. Unless specified following, the regulations for Digilink, Translink, and Lightlink  
Services specified herein apply in addition to the regulations set forth in other  
sections of this tariff.
- F. The rates specified for Digilink, Translink, and Lightlink Services in 6.1.7 following  
contemplate the provision of a digital quality facility utilizing existing interoffice  
carrier equipment and/or exchange cable facilities compatible with this service. If  
equipment, new facilities or changes to existing facilities are required for the  
provision of this service, then charges as specified in Section 8 of the P.S.C. MO.  
No. 22 General Exchange Tariff, Construction and Installation Charges will apply in  
addition to the rates for Digilink, Translink, and Lightlink Services.
- G. Temporary Suspension of Service (Vacation Service) as defined in Section 24 of the  
P.S.C. MO. No. 22 General Exchange Tariff, is not allowed.
- H. The minimum period for which Digilink and Translink Services are furnished and for  
which charges are applicable is six (6) months. The minimum period for Lightlink  
Service is twelve (12) months.

ISSUED:  
September 13, 2006

BY: Darlene N. Terry  
Manager - Tariffs  
5454 W. 110th Street  
Overland Park, KS 66211

EFFECTIVE:  
October 13, 2006

CANCELLED  
February 1, 2009  
Missouri Public  
Service Commission  
JI-2009-0529

**Filed**  
Missouri Public  
Service Commission

PRIVATE LINE SERVICE

6.1 Link Services

6.1.1 General

- A. Digilink®, Translink®, and Lightlink<sup>SM</sup> Services are furnished for Private Line IntraLATA Intraexchange and Interexchange communications by the Telephone Company.
- B. Digilink, Translink, and Lightlink Services are for the transmission of digital signals and uses digital transmission facilities.
- C. Digilink Service provides for the simultaneous two-way transmission of synchronous digital signals at speeds of 19.2 Kbps, 56.0 Kbps, and 64.0 Kbps, where facilities exist.  
  
Translink Service provides for the simultaneous two-way transmission of isochronous digital signals at speeds of 128 Kbps, 256 Kbps, 384 Kbps, 512 Kbps, and 1.544 Mbps (DS1), where facilities exist.  
  
Lightlink Service provides for the simultaneous two-way transmission of isochronous digital signals at a speed of 44.736 Mbps (DS3), where facilities exist.
- D. To ensure satisfactory operation, the terminal equipment provided by the customer must be compatible with the Digilink, Translink, and Lightlink Service channel facility provided by the Telephone Company.
- E. Unless specified following, the regulations for Digilink, Translink, and Lightlink Services specified herein apply in addition to the regulations set forth in other sections of this tariff.
- F. The rates specified for Digilink, Translink, and Lightlink Services in 6.1.7 following contemplate the provision of a digital quality facility utilizing existing interoffice carrier equipment and/or exchange cable facilities compatible with this service. If equipment, new facilities or changes to existing facilities are required for the provision of this service, then charges as specified in Section 8 of the P.S.C. MO. No. 22 General Exchange Tariff, Construction and Installation Charges will apply in addition to the rates for Digilink, Translink, and Lightlink Services.
- G. Temporary Suspension of Service (Vacation Service) as defined in Section 24 of the P.S.C. MO. No. 22 General Exchange Tariff, is not allowed.
- H. The minimum period for which Digilink and Translink Services are furnished and for which charges are applicable is six (6) months. The minimum period for Lightlink Service is twelve (12) months.

ISSUED:  
December 10, 2003

BY: Richard D. Lawson  
State Executive, External Affairs  
319 Madison  
Jefferson City, MO 65101

EFFECTIVE:  
January 10, 2004

**Cancelled**

October 13, 2006

Missouri Public  
Service Commission

**Filed**

Missouri Public  
Service Commission

Embarq Missouri, Inc.  
d/b/a Embarq

Section 6  
Second Revised Page 2  
Cancels First Revised Page 2

PRIVATE LINE SERVICE

6.1 Link Services (Cont'd)

6.1.2 Regulations

A. Description of Service

1. Digilink Service is furnished for the simultaneous two-way transmission of digital signals at synchronous rates **of 56.0 Kbps and 64.0 Kbps** between two or more points located within a LATA. Digilink is furnished for duplex operation only. The required format and interface specifications are contained in Technical Reference Publications TR-NWT-000341 and MDP-326-726. (C)
2. Translink Service provides a high capacity channel for the transmission of 1.544 Mbps isochronous serial data having a line code of Bipolar Return-to-Zero (BPRZ). Translink Service is provided between two points located within a LATA. The required format and interface specifications are contained in Technical Reference Publications GR-54 and GR-342.
3. Fractional DS1 channels are also available and provide simultaneous, two-way transmission at contiguous bit rates of 128, 256, 384 and 512 Kbps. Fractional DS1 Channels operate over the combined bandwidth of adjacent channels to create a contiguous bit rate. Due to technical limitations associated with the provision of Fractional DS1 Channels, this service will be offered only in end offices where a compatible channel bank exists and the distance between the central office and the customer designated premises is less than or equal to twelve thousand (12,000) feet.

ISSUED:  
January 20, 2009

BY: Darlene N. Terry  
Manager - Tariffs  
5454 W. 110th Street  
Overland Park, Kansas 66211

EFFECTIVE:  
February 1, 2009

CANCELLED  
October 19, 2009  
Missouri Public  
Service Commission  
TN-2010-0086; JI-2010-0157

FILED  
Missouri Public  
Service Commission  
JI-2009-0529

PRIVATE LINE SERVICE

6.1 Link Services (Cont'd)

6.1.2 Regulations

A. Description of Service

1. **Digilink** Service is furnished for the simultaneous two-way transmission of digital signals at synchronous rates of 19.2 Kbps, 56.0 Kbps, and 64.0 Kbps between two or more points located within a LATA. Digilink is furnished for duplex operation only. The required format and interface specifications are contained in Technical Reference Publications TR-NWT-000341 and MDP-326-726. (T)
2. **Translink** Service provides a high capacity channel for the transmission of 1.544 Mbps isochronous serial data having a line code of Bipolar Return-to-Zero (BPRZ). Translink Service is provided between two points located within a LATA. The required format and interface specifications are contained in Technical Reference Publications GR-54 and GR-342. (T)
3. Fractional DS1 channels are also available and provide simultaneous, two-way transmission at contiguous bit rates of 128, 256, 384 and 512 Kbps. Fractional DS1 Channels operate over the combined bandwidth of adjacent channels to create a contiguous bit rate. Due to technical limitations associated with the provision of Fractional DS1 Channels, this service will be offered only in end offices where a compatible channel bank exists and the distance between the central office and the customer designated premises is less than or equal to twelve thousand (12,000) feet.

ISSUED:  
September 13, 2006

BY: Darlene N. Terry  
Manager - Tariffs  
5454 W. 110th Street  
Overland Park, KS 66211

EFFECTIVE:  
October 13, 2006

CANCELLED  
February 1, 2009  
Missouri Public  
Service Commission  
JI-2009-0529

**Filed**  
Missouri Public  
Service Commission

PRIVATE LINE SERVICE

6.1 Link Services (Cont'd)

6.1.2 Regulations

A. Description of Service

1. Digilink® Service is furnished for the simultaneous two-way transmission of digital signals at synchronous rates of 19.2 Kbps, 56.0 Kbps, and 64.0 Kbps between two or more points located within a LATA. Digilink is furnished for duplex operation only. The required format and interface specifications are contained in Technical Reference Publications TR-NWT-000341 and MDP-326-726.
2. Translink® Service provides a high capacity channel for the transmission of 1.544 Mbps isochronous serial data having a line code of Bipolar Return-to-Zero (BPRZ). Translink Service is provided between two points located within a LATA. The required format and interface specifications are contained in Technical Reference Publications GR-54 and GR-342.
3. Fractional DS1 channels are also available and provide simultaneous, two-way transmission at contiguous bit rates of 128, 256, 384 and 512 Kbps. Fractional DS1 Channels operate over the combined bandwidth of adjacent channels to create a contiguous bit rate. Due to technical limitations associated with the provision of Fractional DS1 Channels, this service will be offered only in end offices where a compatible channel bank exists and the distance between the central office and the customer designated premises is less than or equal to twelve thousand (12,000) feet.

ISSUED:  
December 10, 2003

BY: Richard D. Lawson  
State Executive, External Affairs  
319 Madison  
Jefferson City, MO 65101

EFFECTIVE:  
January 10, 2004

**Cancelled**

October 13, 2006

Missouri Public  
Service Commission

**Filed**

Missouri Public  
Service Commission

Embarq Missouri, Inc.  
d/b/a Embarq

Section 6  
First Revised Page 3  
Cancels Original Page 3

PRIVATE LINE SERVICE

6.1 Link Services (Cont'd)

6.1.2 Regulations (Cont'd)

A. Description of Service (Cont'd)

4. **Lightlink** Service provides a high capacity channel for the transmission of 44.736 Mbps isochronous serial data having a line code of bipolar three zero substitution (B3ZS). Lightlink Service is provided between two points located within a LATA. Lightlink Service is available utilizing an electrical interface. The interface will have the characteristics of its respective signal at the point of demarcation. The required format and interface specifications are contained in Technical Reference Publication 62508 and 62411, and the associated Addendum TR-INS-000342 and TR-NPL-000054. (T)
5. A Channel Service Unit (CSU) or appropriate termination equipment provided by the customer is required at a customer's or authorized user's premises to perform such functions as:
  - proper termination of the service
  - amplification
  - signal shaping
  - remote loop-back
6. The design, maintenance and operation of **Digilink**, **Translink**, and Lightlink Services contemplate communications originating and terminating as, (1) a customer premises to customer premises channel via the Telephone Company's Serving Wire Center and/or through remote Serving Wire Centers; (2) a customer premises to the Serving Wire Center and/or remote Serving Wire Centers - partial channel (link); or (3) a central office to central office (interoffice) partial channel (link). (T)

ISSUED:  
September 13, 2006

BY: Darlene N. Terry  
Manager - Tariffs  
5454 W. 110th Street  
Overland Park, KS 66211

EFFECTIVE:  
October 13, 2006



PRIVATE LINE SERVICE

6.1 Link Services (Cont'd)

6.1.2 Regulations (Cont'd)

A. Description of Service (Cont'd)

4. Lightlink<sup>SM</sup> Service provides a high capacity channel for the transmission of 44.736 Mbps isochronous serial data having a line code of bipolar three zero substitution (B3ZS). Lightlink Service is provided between two points located within a LATA. Lightlink Service is available utilizing an electrical interface. The interface will have the characteristics of its respective signal at the point of demarcation. The required format and interface specifications are contained in Technical Reference Publication 62508 and 62411, and the associated Addendum TR-INS-000342 and TR-NPL-000054.
5. A Channel Service Unit (CSU) or appropriate termination equipment provided by the customer is required at a customer's or authorized user's premises to perform such functions as:
  - proper termination of the service
  - amplification
  - signal shaping
  - remote loop-back
6. The design, maintenance and operation of Digilink®, Translink®, and Lightlink Services contemplate communications originating and terminating as, (1) a customer premises to customer premises channel via the Telephone Company's Serving Wire Center and/or through remote Serving Wire Centers; (2) a customer premises to the Serving Wire Center and/or remote Serving Wire Centers - partial channel (link); or (3) a central office to central office (interoffice) partial channel (link).

ISSUED:  
December 10, 2003

BY: Richard D. Lawson  
State Executive, External Affairs  
319 Madison  
Jefferson City, MO 65101

EFFECTIVE:  
January 10, 2004

**Cancelled**

October 13, 2006

Missouri Public  
Service Commission

**Filed**

Missouri Public  
Service Commission

PRIVATE LINE SERVICE

6.1 Link Services (Cont'd)

6.1.2 Regulations (Cont'd)

A. Description of Service (Cont'd)

7. Service Configurations

There are two types of service configurations over which Link Services are provided: two-point service and multipoint service. Multipoint service is available with **Digilink** Service and involves applications requiring three or more locations. Multipoint service is not available with **Translink** Service or **Lightlink** Service.

(T)  
|  
(T)

(a) Two-Point Service

A two-point service connects two customer designated premises, either on a directly connected basis or through a hub where multiplexing functions are performed or a customer designated premises.

Applicable rate elements are:

- Channel Terminations
- Channel Mileage (as applicable)
- Optional Features and Functions (when applicable)

The following diagram depicts a two-point service connecting two customer designated premises located 15 miles apart.

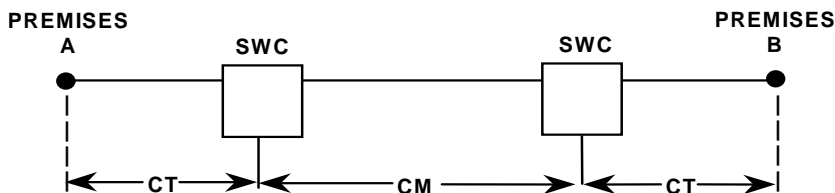

CT Channel Termination  
CM Channel Mileage  
SWC Serving Wire Center

Applicable rate elements are:

- Channel Terminations (2 applicable)
- Channel Mileage (1 Termination and 15 Facility)

ISSUED:  
September 13, 2006

BY: Darlene N. Terry  
Manager - Tariffs  
5454 W. 110th Street  
Overland Park, KS 66211

EFFECTIVE:  
October 13, 2006

PRIVATE LINE SERVICE

6.1 Link Services (Cont'd)

6.1.2 Regulations (Cont'd)

A. Description of Service (Cont'd)

7. Service Configurations

There are two types of service configurations over which Link Services are provided: two-point service and multipoint service. Multipoint service is available with Digilink® Service and involves applications requiring three or more locations. Multipoint service is not available with Translink® Service or Lightlink<sup>SM</sup> Service.

(a) Two-Point Service

A two-point service connects two customer designated premises, either on a directly connected basis or through a hub where multiplexing functions are performed or a customer designated premises.

Applicable rate elements are:

- Channel Terminations
- Channel Mileage (as applicable)
- Optional Features and Functions (when applicable)

The following diagram depicts a two-point service connecting two customer designated premises located 15 miles apart.

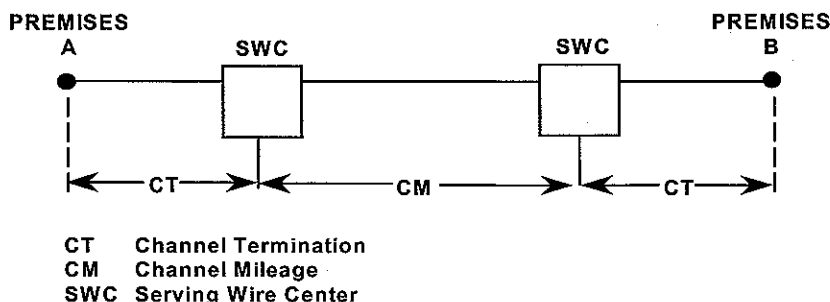

Applicable rate elements are:

- Channel Terminations (2 applicable)
- Channel Mileage (1 Termination and 15 Facility)

ISSUED:  
December 10, 2003

BY: Richard D. Lawson  
State Executive, External Affairs  
319 Madison  
Jefferson City, MO 65101

EFFECTIVE:  
January 10, 2004

**Cancelled**

October 13, 2006

Missouri Public  
Service Commission

**Filed**

Missouri Public  
Service Commission

PRIVATE LINE SERVICE

6.1 Link Services (Cont'd)

6.1.2 Regulations (Cont'd)

A. Description of Service (Cont'd)

7. Service Configurations (Cont'd)

(b) Multipoint Service

Multipoint service connects three or more customer designated premises through a Telephone Company hub. There is no limitation on the number of mid-links available with multipoint service. However, when more than three mid-links are provided in tandem, the quality of the service may be degraded. A mid-link is a channel between hubs (i.e., bridging locations).

Applicable rate elements are:

- Channel Terminations (one per customer designated premises)
- Channel Mileage (as applicable between each designated customer premises and the hub, and between hubs)
- Additional Optional Features and Functions (when applicable)

ISSUED:  
December 10, 2003

BY: Richard D. Lawson  
State Executive, External Affairs  
319 Madison  
Jefferson City, MO 65101

EFFECTIVE:  
January 10, 2004

PRIVATE LINE SERVICE

6.1 Link Services (Cont'd)

6.1.2 Regulations (Cont'd)

A. Description of Service (Cont'd)

7. Service Configurations (Cont'd)

(b) Multipoint Service (Cont'd)

The following diagram depicts a service connecting four customer premises via two customer specified bridging hubs.

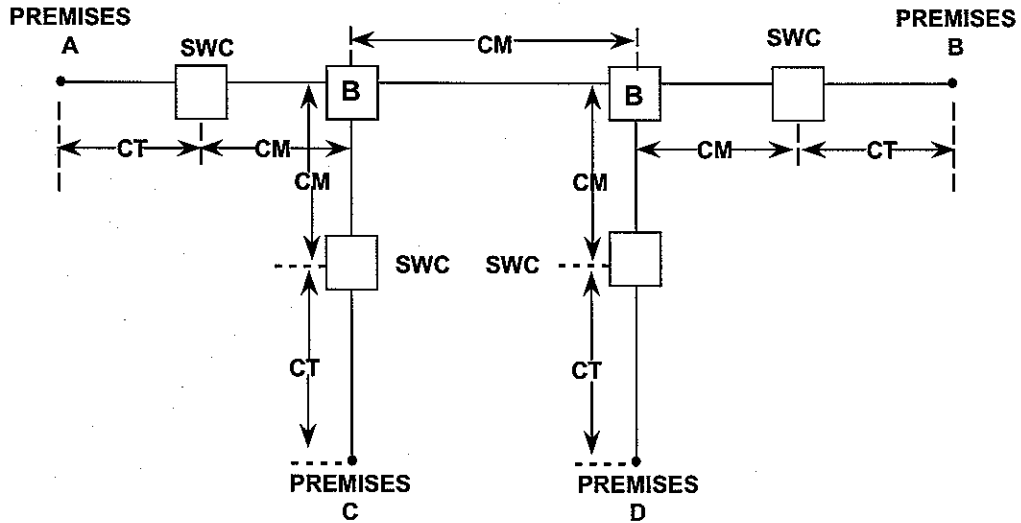

- CT - Channel Termination
- CM - Channel Mileage
- B - Bridging
- SWC - Serving Wire Center

Applicable rate elements are:

- Channel Terminations (4 applicable)
- Channel Mileage (5 sections, Termination and Facility as appropriate)
- Bridging (6 applicable, i.e., each bridge port)

ISSUED:  
December 10, 2003

BY: Richard D. Lawson  
State Executive, External Affairs  
319 Madison  
Jefferson City, MO 65101

EFFECTIVE:  
January 10, 2004

PRIVATE LINE SERVICE

6.1 Link Services (Cont'd)

6.1.2 Regulations (Cont'd)

B. Definitions

1. Central Office Bridging Capability - Provides for the parallel connection of one virtual circuit to another virtual circuit without interrupting the integrity or continuity of the first. This service is only available from a Telephone Company-designated digital hub.
2. Channel Mileage - Provides for the end office equipment and the transmission channel between the Serving Wire Centers associated with two customer designated premises, between a Serving Wire Center associated with a customer designated premises and a Telephone Company hub, or between two Telephone Company hubs. Channel Mileage is comprised of Channel Mileage Facility (per mile) and Channel Mileage Termination (fixed) rates.
  - (a) Channel Mileage Facility (Per Mile) - The Channel Mileage Facility (per mile) recovers the cost for the transmission path that extends between the Telephone Company Serving Wire Centers and/or hub(s) and includes primarily outside plant used to provide the facility.
  - (b) Channel Mileage Termination (Fixed) - Channel Mileage Termination (fixed) recovers the cost for end office equipment associated with terminating the facility (i.e., basic circuit equipment and terminations at Serving Wire Centers).
3. Channel Service Unit (CSU) - Denotes equipment provided by the customer which performs one or more of the following functions: termination of a digital facility, regeneration of digital signals, detection and/or correction of signal format errors and remote loop back.
4. Channel Termination - The local facility from the customer's designated premises to the Serving Wire Center.
5. Data Amplification - Provides for data transmission when the customer is located beyond the normal range for high speed digital data service. Channel Terminations greater than five (5) cable route miles in length for 19.2 Kbps service or three (3) miles in length for 56 Kbps and 64 Kbps service may require circuit repeaters and associated equipment be installed to regenerate the digital signal in order for accurate and acceptable data transmission to occur. The distances given are an indication of the potential requirement for Data Amplification. The actual distance is dependent on decibel (db) loss and not just physical loop length and is a function of the specific Telephone Company cable between the Serving Wire Center and the customer's location.

ISSUED:  
December 10, 2003

BY: Richard D. Lawson  
State Executive, External Affairs  
319 Madison  
Jefferson City, MO 65101

EFFECTIVE:  
January 10, 2004

PRIVATE LINE SERVICE

6.1 Link Services (Cont'd)

6.1.2 Regulations (Cont'd)

B. Definitions (Cont'd)

6. Clear Channel Capability (CCC) - Denotes the transport of twenty-four, 64 Kbps channels over a 1.544 Mbps **Translink** Service via B8ZS line code format. (T)
7. Customer Designated Premises - Denotes the premises specified by the customer for the provision of Link Services.
8. DS3 - Denotes a channel service expressed in terms of its digitally encoded data bit rate in accordance with the North American hierarchy of digital signal levels. It has a 44.736 Mbps transmission data rate, and provides for the two-way simultaneous transmission of randomized Non-Return-to-Zero (NRZ) signals with B3ZS format.
9. Hub - A Telephone Company designated Serving Wire Center at which bridging or multiplexing functions are performed. The bridging functions performed may be used to connect three or more customer designated premises in a multipoint arrangement. The multiplexing functions are to channelize digital facilities to individual services requiring a lower capacity or bandwidth.
10. Multipoint Service - Connects three or more customer designated premises through a Telephone Company hub. There is no limitation on the number of mid-links available with multipoint service. However, when more than three mid-links are provided in tandem, the quality of the service may be degraded. A mid-link is a channel between hubs (i.e., bridging locations).
11. Nonrecurring Charge - A one-time charge for the initial installation, the installation of functions and features and service rearrangements.
12. Serving Wire Center - Denotes the wire center from which the customer designated premises would normally obtain dial tone from the Telephone Company.
13. Two-Point Service - Connects two customer designated premises, either on a directly connected basis or through a hub where multiplexing functions are performed or a customer designated premises.

ISSUED:  
September 13, 2006

BY: Darlene N. Terry  
Manager - Tariffs  
5454 W. 110th Street  
Overland Park, KS 66211

EFFECTIVE:  
October 13, 2006

PRIVATE LINE SERVICE

6.1 Link Services (Cont'd)

6.1.2 Regulations (Cont'd)

B. Definitions (Cont'd)

6. Clear Channel Capability (CCC) - Denotes the transport of twenty-four, 64 Kbps channels over a 1.544 Mbps Translink® Service via B8ZS line code format.
7. Customer Designated Premises - Denotes the premises specified by the customer for the provision of Link Services.
8. DS3 - Denotes a channel service expressed in terms of its digitally encoded data bit rate in accordance with the North American hierarchy of digital signal levels. It has a 44.736 Mbps transmission data rate, and provides for the two-way simultaneous transmission of randomized Non-Return-to-Zero (NRZ) signals with B3ZS format.
9. Hub - A Telephone Company designated Serving Wire Center at which bridging or multiplexing functions are performed. The bridging functions performed may be used to connect three or more customer designated premises in a multipoint arrangement. The multiplexing functions are to channelize digital facilities to individual services requiring a lower capacity or bandwidth.
10. Multipoint Service - Connects three or more customer designated premises through a Telephone Company hub. There is no limitation on the number of mid-links available with multipoint service. However, when more than three mid-links are provided in tandem, the quality of the service may be degraded. A mid-link is a channel between hubs (i.e., bridging locations).
11. Nonrecurring Charge - A one-time charge for the initial installation, the installation of functions and features and service rearrangements.
12. Serving Wire Center - Denotes the wire center from which the customer designated premises would normally obtain dial tone from the Telephone Company.
13. Two-Point Service - Connects two customer designated premises, either on a directly connected basis or through a hub where multiplexing functions are performed or a customer designated premises.

ISSUED:  
December 10, 2003

BY: Richard D. Lawson  
State Executive, External Affairs  
319 Madison  
Jefferson City, MO 65101

EFFECTIVE:  
January 10, 2004

**Cancelled**

October 13, 2006

Missouri Public  
Service Commission

**Filed**

Missouri Public  
Service Commission



PRIVATE LINE SERVICE

6.1 Link Services (Cont'd)

6.1.2 Regulations (Cont'd)

C. Connections

1. Customer-Provided Terminal Equipment, Customer-Provided Derivation Equipment and Customer-Provided Communications Systems may be connected to **Digilink**, **Translink** and **Lightlink** Services when such connection is made in accordance with the provisions specified in 2, 3 and 4 following.

(T)

2. Responsibility of the Telephone Company

(a) The responsibility of the Telephone Company shall be limited to the furnishing and maintenance of Digilink, Translink and Lightlink Services to a network interface on the customer's premises where provision is made for the connection of local service.

(b) The Telephone Company shall not be responsible for installation, operation or maintenance of any terminal equipment or communications systems provided by the customer. Digilink, Translink and Lightlink Services are not represented as adapted for the use of such equipment or system. Where such equipment or system is connected to Telephone Company facilities, the responsibility of the Telephone Company shall be limited to the furnishing of facilities suitable for Digilink, Translink and Lightlink Services and to the maintenance and operation in a manner proper for such digital service. The Telephone Company shall not be responsible for:

- The through transmission of signals generated by such equipment or system, or for the quality of, or defects in, such transmission, or
- The reception of signals by such equipment or systems, or
- Damage to terminal equipment or communications systems provided by a customer or authorized user due to testing.

(c) The Telephone Company shall not be responsible to the customer if changes in any of the facilities, operations or procedures of the Telephone Company utilized in the provision of Digilink, Translink and Lightlink Services render any facilities or equipment provided by a customer obsolete, or require modification or alteration of such equipment or system or otherwise affects its use or performance.

ISSUED:  
September 13, 2006

BY: Darlene N. Terry  
Manager - Tariffs  
5454 W. 110th Street  
Overland Park, KS 66211

EFFECTIVE:  
October 13, 2006

PRIVATE LINE SERVICE

6.1 Link Services (Cont'd)

6.1.2 Regulations (Cont'd)

C. Connections

1. Customer-Provided Terminal Equipment, Customer-Provided Derivation Equipment and Customer-Provided Communications Systems may be connected to Digilink®, Translink® and Lightlink<sup>SM</sup> Services when such connection is made in accordance with the provisions specified in 2, 3 and 4 following.
2. Responsibility of the Telephone Company
  - (a) The responsibility of the Telephone Company shall be limited to the furnishing and maintenance of Digilink, Translink and Lightlink Services to a network interface on the customer's premises where provision is made for the connection of local service.
  - (b) The Telephone Company shall not be responsible for installation, operation or maintenance of any terminal equipment or communications systems provided by the customer. Digilink, Translink and Lightlink Services are not represented as adapted for the use of such equipment or system. Where such equipment or system is connected to Telephone Company facilities, the responsibility of the Telephone Company shall be limited to the furnishing of facilities suitable for Digilink, Translink and Lightlink Services and to the maintenance and operation in a manner proper for such digital service. The Telephone Company shall not be responsible for:
    - The through transmission of signals generated by such equipment or system, or for the quality of, or defects in, such transmission, or
    - The reception of signals by such equipment or systems, or
    - Damage to terminal equipment or communications systems provided by a customer or authorized user due to testing.
  - (c) The Telephone Company shall not be responsible to the customer if changes in any of the facilities, operations or procedures of the Telephone Company utilized in the provision of Digilink, Translink and Lightlink Services render any facilities or equipment provided by a customer obsolete, or require modification or alteration of such equipment or system or otherwise affects its use or performance.

ISSUED:  
December 10, 2003

BY: Richard D. Lawson  
State Executive, External Affairs  
319 Madison  
Jefferson City, MO 65101

EFFECTIVE:  
January 10, 2004

**Cancelled**

October 13, 2006

Missouri Public  
Service Commission

**Filed**

Missouri Public  
Service Commission

PRIVATE LINE SERVICE

6.1. Link Services (Cont'd)

6.1.2 Regulations (Cont'd)

C. Connections (Cont'd)

2. Responsibility of the Telephone Company (Cont'd)

(d) The Telephone Company is responsible for maintaining and repairing the facilities it furnishes. The customer may not rearrange, disconnect, remove or attempt to repair any equipment installed by the Telephone Company without prior written consent of the Telephone Company.

(e) **Digilink, Translink, and Lightlink** Services are designed to meet or exceed a performance objective of 99% error-free seconds of transmission per 1000 seconds on a daily basis and 99.9% availability on an annual basis when measured through the digital termination equipment. (T)

(f) In order to maintain the quality of Digilink, Translink and Lightlink Services, the Telephone Company reserves the right to perform preventative maintenance and software updates to the network. The Telephone Company has classified maintenance as follows:

(i) Scheduled Maintenance

Scheduled maintenance is performed for functions such as hardware and software upgrades and network optimization. The Telephone Company will perform these tasks in a maintenance window that is anticipated to minimize disruption of customer service and activity. The Telephone Company will provide advance notice of all scheduled maintenance.

(ii) Demand Maintenance

Demand maintenance may occur as a result of unexpected events and is performed when Digilink, Translink and Lightlink Services network elements are in jeopardy. The Telephone Company will perform this type of maintenance at its discretion. Due to the nature of demand maintenance, prior notification may not be possible; however, the customer will be informed when the maintenance has been completed.

ISSUED:  
September 13, 2006

BY: Darlene N. Terry  
Manager - Tariffs  
5454 W. 110th Street  
Overland Park, KS 66211

EFFECTIVE:  
October 13, 2006

PRIVATE LINE SERVICE

6.1. Link Services (Cont'd)

6.1.2 Regulations (Cont'd)

C. Connections (Cont'd)

2. Responsibility of the Telephone Company (Cont'd)

(d) The Telephone Company is responsible for maintaining and repairing the facilities it furnishes. The customer may not rearrange, disconnect, remove or attempt to repair any equipment installed by the Telephone Company without prior written consent of the Telephone Company.

(e) Digilink®, Translink® and Lightlink<sup>SM</sup> Services are designed to meet or exceed a performance objective of 99% error-free seconds of transmission per 1000 seconds on a daily basis and 99.9% availability on an annual basis when measured through the digital termination equipment.

(f) In order to maintain the quality of Digilink, Translink and Lightlink Services, the Telephone Company reserves the right to perform preventative maintenance and software updates to the network. The Telephone Company has classified maintenance as follows:

(i) Scheduled Maintenance

Scheduled maintenance is performed for functions such as hardware and software upgrades and network optimization. The Telephone Company will perform these tasks in a maintenance window that is anticipated to minimize disruption of customer service and activity. The Telephone Company will provide advance notice of all scheduled maintenance.

(ii) Demand Maintenance

Demand maintenance may occur as a result of unexpected events and is performed when Digilink, Translink and Lightlink Services network elements are in jeopardy. The Telephone Company will perform this type of maintenance at its discretion. Due to the nature of demand maintenance, prior notification may not be possible; however, the customer will be informed when the maintenance has been completed.

ISSUED:  
December 10, 2003

BY: Richard D. Lawson  
State Executive, External Affairs  
319 Madison  
Jefferson City, MO 65101

EFFECTIVE:  
January 10, 2004

**Cancelled**

October 13, 2006

Missouri Public  
Service Commission

**Filed**

Missouri Public  
Service Commission

PRIVATE LINE SERVICE

6.1 Link Services (Cont'd)

6.1.2 Regulations (Cont'd)

C. Connections (Cont'd)

3. Responsibility of the Customer

- (a) The customer is responsible for installing and testing the customer premises equipment or facilities to insure that when they are connected to **Digilink, Translink, and Lightlink** Services such equipment or facilities are operating properly. (T)
- (b) The operating characteristics of the customer premises equipment or facilities shall be such as to not interfere with any of the services offered by the Telephone Company. Such use is subject to the further provisions that the equipment provided by a customer does not: endanger the safety of Telephone Company employees or the public; damage, require change in or alteration of the equipment or other facilities of the Telephone Company; interfere with the proper functioning of such equipment or facilities; impair the operation of the Telephone Company's facilities or otherwise injure the public in its use of the Telephone Company's services. Upon notice that the equipment provided by a customer is causing or is likely to cause such hazard or interference, the customer shall take such steps as shall be necessary to remove or prevent such hazard or interference.
- (c) The customer's responsibility shall include cooperative testing with the Telephone Company as may be necessary. Where regeneration and/or equalization adjustments or changes may be required to compensate for rearrangements and/or changes in outside plant facilities, the customer will be responsible for all expenses incurred in changes to his customer premises equipment.

4. Connection of Customer-Provided Terminal Equipment, Customer-Provided Derivation Equipment and Customer-Provided Communications Systems

- (a) The following provisions will apply:
  - (i) Customer-Provided Terminal Equipment and/or Customer-Provided Communications Systems may be connected at the premises of the customer to Digilink, Translink and Lightlink Services.

ISSUED:  
September 13, 2006

BY: Darlene N. Terry  
Manager - Tariffs  
5454 W. 110th Street  
Overland Park, KS 66211

EFFECTIVE:  
October 13, 2006

PRIVATE LINE SERVICE

6.1 Link Services (Cont'd)

6.1.2 Regulations (Cont'd)

C. Connections (Cont'd)

3. Responsibility of the Customer

- (a) The customer is responsible for installing and testing the customer premises equipment or facilities to insure that when they are connected to Digilink®, Translink® and Lightlink<sup>SM</sup> Services such equipment or facilities are operating properly.
- (b) The operating characteristics of the customer premises equipment or facilities shall be such as to not interfere with any of the services offered by the Telephone Company. Such use is subject to the further provisions that the equipment provided by a customer does not: endanger the safety of Telephone Company employees or the public; damage, require change in or alteration of the equipment or other facilities of the Telephone Company; interfere with the proper functioning of such equipment or facilities; impair the operation of the Telephone Company's facilities or otherwise injure the public in its use of the Telephone Company's services. Upon notice that the equipment provided by a customer is causing or is likely to cause such hazard or interference, the customer shall take such steps as shall be necessary to remove or prevent such hazard or interference.
- (c) The customer's responsibility shall include cooperative testing with the Telephone Company as may be necessary. Where regeneration and/or equalization adjustments or changes may be required to compensate for rearrangements and/or changes in outside plant facilities, the customer will be responsible for all expenses incurred in changes to his customer premises equipment.

4. Connection of Customer-Provided Terminal Equipment, Customer-Provided Derivation Equipment and Customer-Provided Communications Systems

- (a) The following provisions will apply:
  - (i) Customer-Provided Terminal Equipment and/or Customer-Provided Communications Systems may be connected at the premises of the customer to Digilink, Translink and Lightlink Services.

ISSUED:  
December 10, 2003

BY: Richard D. Lawson  
State Executive, External Affairs  
319 Madison  
Jefferson City, MO 65101

EFFECTIVE:  
January 10, 2004

**Cancelled**

October 13, 2006

Missouri Public  
Service Commission

**Filed**

Missouri Public  
Service Commission

PRIVATE LINE SERVICE

6.1 Link Services (Cont'd)

6.1.2 Regulations (Cont'd)

C. Connections (Cont'd)

4. Connection of Customer-Provided ... (Cont'd)

(a) The following provisions will apply: (Cont'd)

(ii) The customers, by use of their own derivation equipment, may create digital bit streams from **Digilink**, **Translink**, and **Lightlink** Services and such equipment may be connected for transmission of such bit streams when connected through a customer-provided CSU. (T)

(iii) The undertaking of the Telephone Company is to furnish Digilink, Translink and Lightlink Services as ordered and specified by the customer except as specified in (d) following.

(b) Connections to Other Services Furnished by the Company to the Same Customer

Digilink, Translink and Lightlink Services furnished by the Telephone Company may be connected by the customer to another service or to other services furnished by the Telephone Company as specified in 2 preceding. Connected services are subject to all rules and regulations governing the provisioning of those services.

(c) Connections to Other Services Furnished by the Telephone Company to Different Customers

The customer may connect at the premises of the customer, to another Digilink, Translink and Lightlink Service or other services furnished by the Telephone Company to different customers as specified in 2 preceding. Connected services are subject to all rules and regulations governing provisioning of those services.

(d) Connection of Channel Service Units

A Channel Service Unit (CSU) or appropriate termination equipment must be provided by the customer to connect a Telephone Company-provided digital facility. This equipment must comply with the technical requirements outlined in Part 68 of the FCC Rules and Regulations.

ISSUED:  
September 13, 2006

BY: Darlene N. Terry  
Manager - Tariffs  
5454 W. 110th Street  
Overland Park, KS 66211

EFFECTIVE:  
October 13, 2006

PRIVATE LINE SERVICE

6.1 Link Services (Cont'd)

6.1.2 Regulations (Cont'd)

C. Connections (Cont'd)

4. Connection of Customer-Provided ... (Cont'd)

(a) The following provisions will apply: (Cont'd)

(ii) The customers, by use of their own derivation equipment, may create digital bit streams from Digilink®, Translink® and Lightlink<sup>SM</sup> Services and such equipment may be connected for transmission of such bit streams when connected through a customer-provided CSU.

(iii) The undertaking of the Telephone Company is to furnish Digilink, Translink and Lightlink Services as ordered and specified by the customer except as specified in (d) following.

(b) Connections to Other Services Furnished by the Company to the Same Customer

Digilink, Translink and Lightlink Services furnished by the Telephone Company may be connected by the customer to another service or to other services furnished by the Telephone Company as specified in 2 preceding. Connected services are subject to all rules and regulations governing the provisioning of those services.

(c) Connections to Other Services Furnished by the Telephone Company to Different Customers

The customer may connect at the premises of the customer, to another Digilink, Translink and Lightlink Service or other services furnished by the Telephone Company to different customers as specified in 2 preceding. Connected services are subject to all rules and regulations governing provisioning of those services.

(d) Connection of Channel Service Units

A Channel Service Unit (CSU) or appropriate termination equipment must be provided by the customer to connect a Telephone Company-provided digital facility. This equipment must comply with the technical requirements outlined in Part 68 of the FCC Rules and Regulations.

ISSUED:  
December 10, 2003

BY: Richard D. Lawson  
State Executive, External Affairs  
319 Madison  
Jefferson City, MO 65101

EFFECTIVE:  
January 10, 2004

**Cancelled**

October 13, 2006

Missouri Public  
Service Commission

**Filed**

Missouri Public  
Service Commission



PRIVATE LINE SERVICE

6.1 Link Services (Cont'd)

6.1.2 Regulations (Cont'd)

C. Connections (Cont'd)

4. Connection of Customer-Provided ... (Cont'd)

- (e) The customer shall be responsible for payment of a Maintenance of Service Charge, as set forth in Section 7 of the P.S.C. MO. No. 22 General Exchange Tariff, for visits by the Telephone Company to the customer's premises where the service difficulty or trouble report results from the use of equipment or facilities provided by the customer.
- (f) The customer may not rearrange, disconnect, remove or attempt to repair any equipment installed by the Telephone Company without the prior written consent of the Telephone Company.
- (g) For maintenance purposes, upon request of the Telephone Company, the customer will be responsible for notifying the Telephone Company of the type of digital terminating equipment used.

6.1.3 Term Discount Plan (TDP)

- A. A Term Discount Plan (TDP) provides the customer with discounted rates for **Digilink**, **Translink**, and **Lightlink** Services. Digilink, Translink and Lightlink Service may be ordered under a TDP for fixed periods of 12 - 23 months, 24 - 35 months, 36 - 59 months, and 60 - 84 months. For Lightlink Service, month-to-month rates may apply only after the expiration of a TDP. All rate elements within the same Digilink, Translink and Lightlink Service facilities must be ordered under the same commitment period and under the same service date. The customer must order the TDP in writing to the Company. A TDP may be ordered in one-month increments, (e.g. a 28-month commitment period or a 37-month commitment period). (T)
- B. The customer must specify the length of the initial service period at the time the service is ordered. When a customer converts to a TDP, Nonrecurring Charges do not apply toward facilities in-service at that time. If a customer converts from month-to-month rates to a TDP or upgrades from one TDP to another, Nonrecurring Charges and Service Connection Charges do not apply. (T)
- C. At the end of the TDP the customer may subscribe to a new TDP at the prevailing rates set forth in 6.1.7 following. If the customer does not select a new TDP, the rates will convert to the prevailing month-to-month rates.
- D. Rate increases or decreases will automatically be applied to the monthly term plan rates for the remaining term of the TDP. If Telephone Company initiated rate increases to any rate element or combination of rate elements causes the charges for the entire Digilink, Translink or Lightlink Service under the TDP to increase by 10% or more annually, then the customer may cancel the TDP without incurring termination liability charges provided the customer notifies the Telephone Company within 30 days after the effective date of the rate increase.

ISSUED:  
September 13, 2006

BY: Darlene N. Terry  
Manager - Tariffs  
5454 W. 110th Street  
Overland Park, KS 66211

EFFECTIVE:  
October 13, 2006

## PRIVATE LINE SERVICE

6.1 Link Services (Cont'd)6.1.2 Regulations (Cont'd)

## C. Connections (Cont'd)

## 4. Connection of Customer-Provided ... (Cont'd)

- (e) The customer shall be responsible for payment of a Maintenance of Service Charge, as set forth in Section 7 of the P.S.C. MO. No. 22 General Exchange Tariff, for visits by the Telephone Company to the customer's premises where the service difficulty or trouble report results from the use of equipment or facilities provided by the customer.
- (f) The customer may not rearrange, disconnect, remove or attempt to repair any equipment installed by the Telephone Company without the prior written consent of the Telephone Company.
- (g) For maintenance purposes, upon request of the Telephone Company, the customer will be responsible for notifying the Telephone Company of the type of digital terminating equipment used.

6.1.3 Term Discount Plan (TDP)

- A. A Term Discount Plan (TDP) provides the customer with discounted rates for Digilink®, Translink® and Lightlink<sup>SM</sup> Services. Digilink, Translink and Lightlink Service may be ordered under a TDP for fixed periods of 12 - 23 months, 24 - 35 months, 36 - 59 months, and 60 - 84 months. For Lightlink Service, month-to-month rates may apply only after the expiration of a TDP. All rate elements within the same Digilink, Translink and Lightlink Service facilities must be ordered under the same commitment period and under the same service date. The customer must order the TDP in writing to the Company. A TDP may be ordered in one-month increments, (e.g. a 28-month commitment period or a 37-month commitment period).
- B. The customer must specify the length of the initial service period at the time the service is ordered. When a customer converts to a TDP, Nonrecurring Charges do not apply toward facilities in-service at that time. If a customer converts from month-to-month rates to a TDP or upgrades from one TDP to another, Nonrecurring Charges and Service Connection Charges do not apply.
- C. At the end of the TDP the customer may subscribe to a new TDP at the prevailing rates set forth in 6.1.7 following. If the customer does not select a new TDP, the rates will convert to the prevailing month-to-month rates.
- D. Rate increases or decreases will automatically be applied to the monthly term plan rates for the remaining term of the TDP. If Telephone Company initiated rate increases to any rate element or combination of rate elements causes the charges for the entire Digilink, Translink or Lightlink Service under the TDP to increase by 10% or more annually, then the customer may cancel the TDP without incurring termination liability charges provided the customer notifies the Telephone Company within 30 days after the effective date of the rate increase.

ISSUED:  
December 10, 2003BY: Richard D. Lawson  
State Executive, External Affairs  
319 Madison  
Jefferson City, MO 65101EFFECTIVE:  
January 10, 2004**Cancelled**

October 13, 2006

Missouri Public  
Service Commission**Filed**Missouri Public  
Service Commission

PRIVATE LINE SERVICE

6.1 Link Services (Cont'd)

6.1.3 Term Discount Plan (TDP) (Cont'd)

- E. The customer can extend TDP commitment periods at any time during the term of the plan, up to a maximum of 84 months. The number of remaining months in the original term plan will become part of the total term in the new term plan.

6.1.4 Termination Liability Charges

- A. If a customer under a Term Discount Plan (TDP) disconnects all or a portion of **Digilink**, **Translink**, and **Lightlink** Service prior to the expiration of the TDP, then a Termination Liability Charge will apply to those services that are disconnected. The Termination Liability Charge will be a one-time charge equal to sum of 50% of the payments remaining for the rest of the TDP. (T)
- B. Customers may move Channel Terminations and not be subject to Termination Liability Charges providing the terms of the TDP are maintained. If charges as specified in 6.1.1.F. were applied to the service being terminated or moved, any termination or move charges associated with that construction apply, as well as any construction charges at the new location.
- C. Termination Liability Charges will not apply when a service or rate element under a TDP is disconnected prior to the expiration of a selected service period as a result of a change in tariff jurisdiction and/or a customer requested upgrade to a next generation service offering, under the following conditions:
  - 1. The service period of the new TDP for the new service offering is a period equal to or exceeding the remaining service period of the disconnected TDP, and
  - 2. The service orders to install the new service and disconnect the old service are related together, and there is no lapse in service between the installation of the new service and the disconnection of the old service, and
  - 3. The service orders to install the new service and disconnect the old service are for the same customer at the same location.
- D. The Telephone Company will determine whether the replacement service qualifies as a next generation service offering.
- E. Nonrecurring charges and Service Connection Charges for the new service will apply according to the requirements of the new service.

ISSUED:  
September 13, 2006

BY: Darlene N. Terry  
Manager - Tariffs  
5454 W. 110th Street  
Overland Park, KS 66211

EFFECTIVE:  
October 13, 2006

PRIVATE LINE SERVICE

6.1 Link Services (Cont'd)

6.1.3 Term Discount Plan (TDP) (Cont'd)

- E. The customer can extend TDP commitment periods at any time during the term of the plan, up to a maximum of 84 months. The number of remaining months in the original term plan will become part of the total term in the new term plan.

6.1.4 Termination Liability Charges

- A. If a customer under a Term Discount Plan (TDP) disconnects all or a portion of Digilink®, Translink® or Lightlink<sup>SM</sup> Service prior to the expiration of the TDP, then a Termination Liability Charge will apply to those services that are disconnected. The Termination Liability Charge will be a one-time charge equal to sum of 50% of the payments remaining for the rest of the TDP.
- B. Customers may move Channel Terminations and not be subject to Termination Liability Charges providing the terms of the TDP are maintained. If charges as specified in 6.1.1.F. were applied to the service being terminated or moved, any termination or move charges associated with that construction apply, as well as any construction charges at the new location.
- C. Termination Liability Charges will not apply when a service or rate element under a TDP is disconnected prior to the expiration of a selected service period as a result of a change in tariff jurisdiction and/or a customer requested upgrade to a next generation service offering, under the following conditions:
  - 1. The service period of the new TDP for the new service offering is a period equal to or exceeding the remaining service period of the disconnected TDP, and
  - 2. The service orders to install the new service and disconnect the old service are related together, and there is no lapse in service between the installation of the new service and the disconnection of the old service, and
  - 3. The service orders to install the new service and disconnect the old service are for the same customer at the same location.
- D. The Telephone Company will determine whether the replacement service qualifies as a next generation service offering.
- E. Nonrecurring charges and Service Connection Charges for the new service will apply according to the requirements of the new service.

ISSUED:  
December 10, 2003

BY: Richard D. Lawson  
State Executive, External Affairs  
319 Madison  
Jefferson City, MO 65101

EFFECTIVE:  
January 10, 2004

**Cancelled**

October 13, 2006

Missouri Public  
Service Commission

**Filed**

Missouri Public  
Service Commission

PRIVATE LINE SERVICE

6.1 Link Services (Cont'd)

6.1.5 Rate Categories

A. **Digilink** Service

(T)

There are two rate categories which apply to **Digilink** Service:

(T)

- Channel Termination
- Channel Mileage

1. Channel Termination

The Channel Termination rate category provides for the communications path between a customer designated premises and the Serving Wire Center. Included as part of the Channel Termination is a standard channel interface arrangement which defines the technical characteristics associated with the type of facilities to which the service is to be connected at the point of termination (POT) and the type of signaling capability if any. The signaling capability itself is provided as a part of this rate category. One Channel Termination charge applies per customer designated premises at which the channel is terminated. Channel Termination charges are set forth in 6.1.7.A.

2. Channel Mileage

The Channel Mileage rate category provides for the end office equipment and the transmission channel between the Serving Wire Centers associated with two customer designated premises, between a Serving Wire Center associated with a customer designated premises and a Telephone Company hub, or between two Company hubs. Channel Mileage rates are made up of the Channel Mileage Facility (per mile) rate and the Channel Mileage Termination (fixed) rate. Channel Mileage charges are set forth in 6.1.7.B.

ISSUED:  
September 13, 2006

BY: Darlene N. Terry  
Manager - Tariffs  
5454 W. 110th Street  
Overland Park, KS 66211

EFFECTIVE:  
October 13, 2006

PRIVATE LINE SERVICE

6.1 Link Services (Cont'd)

6.1.5 Rate Categories

A. Digilink® Service

There are two rate categories which apply to Digilink® Service:

- Channel Termination
- Channel Mileage

1. Channel Termination

The Channel Termination rate category provides for the communications path between a customer designated premises and the Serving Wire Center. Included as part of the Channel Termination is a standard channel interface arrangement which defines the technical characteristics associated with the type of facilities to which the service is to be connected at the point of termination (POT) and the type of signaling capability if any. The signaling capability itself is provided as a part of this rate category. One Channel Termination charge applies per customer designated premises at which the channel is terminated. Channel Termination charges are set forth in 6.1.7.A.

2. Channel Mileage

The Channel Mileage rate category provides for the end office equipment and the transmission channel between the Serving Wire Centers associated with two customer designated premises, between a Serving Wire Center associated with a customer designated premises and a Telephone Company hub, or between two Company hubs. Channel Mileage rates are made up of the Channel Mileage Facility (per mile) rate and the Channel Mileage Termination (fixed) rate. Channel Mileage charges are set forth in 6.1.7.B.

ISSUED:  
December 10, 2003

BY: Richard D. Lawson  
State Executive, External Affairs  
319 Madison  
Jefferson City, MO 65101

EFFECTIVE:  
January 10, 2004

**Cancelled**

October 13, 2006

Missouri Public  
Service Commission

**Filed**

Missouri Public  
Service Commission

Embarq Missouri, Inc.  
d/b/a Embarq

Section 6  
First Revised Page 16  
Cancels Original Page 16

PRIVATE LINE SERVICE

6.1 Link Services (Cont'd)

6.1.5 Rate Categories (Cont'd)

A. **Digilink** Service (Cont'd)

(T)

2. Channel Mileage (Cont'd)

(a) Channel Mileage Facility (Per Mile)

The Channel Mileage Facility (per mile) rate recovers the cost for the transmission path, which extends between the Telephone Company Serving Wire Centers and/or hub(s) and includes primarily outside plant used to provide the facility.

(b) Channel Mileage Termination (Fixed)

The Channel Mileage Termination (fixed) rate recovers the cost for end office equipment associated with terminating the facility (i.e., basic circuit equipment and terminations at Serving Wire Centers). The Telephone Company applies a 50% billing percentage to the channel mileage fixed rate on jointly owned circuits, and applies 100% on wholly owned circuits. When the Channel Mileage Facility (per mile) is zero (i.e., collocated Serving Wire Centers), neither the Channel Mileage Facility (per mile) rate nor the Channel Mileage Termination (fixed) rate will apply.

ISSUED:  
September 13, 2006

BY: Darlene N. Terry  
Manager - Tariffs  
5454 W. 110th Street  
Overland Park, KS 66211

EFFECTIVE:  
October 13, 2006

PRIVATE LINE SERVICE

6.1 Link Services (Cont'd)

6.1.5 Rate Categories (Cont'd)

A. Digilink® Service (Cont'd)

2. Channel Mileage (Cont'd)

(a) Channel Mileage Facility (Per Mile)

The Channel Mileage Facility (per mile) rate recovers the cost for the transmission path, which extends between the Telephone Company Serving Wire Centers and/or hub(s) and includes primarily outside plant used to provide the facility.

(b) Channel Mileage Termination (Fixed)

The Channel Mileage Termination (fixed) rate recovers the cost for end office equipment associated with terminating the facility (i.e., basic circuit equipment and terminations at Serving Wire Centers). The Telephone Company applies a 50% billing percentage to the channel mileage fixed rate on jointly owned circuits, and applies 100% on wholly owned circuits. When the Channel Mileage Facility (per mile) is zero (i.e., collocated Serving Wire Centers), neither the Channel Mileage Facility (per mile) rate nor the Channel Mileage Termination (fixed) rate will apply.

ISSUED:  
December 10, 2003

BY: Richard D. Lawson  
State Executive, External Affairs  
319 Madison  
Jefferson City, MO 65101

EFFECTIVE:  
January 10, 2004

**Cancelled**  
October 13, 2006

Missouri Public  
Service Commission

**Filed**  
Missouri Public  
Service Commission



PRIVATE LINE SERVICE

6.1 Link Services (Cont'd)

6.1.5 Rate Categories (Cont'd)

B. **Translink** Service

(T)

There are two rate categories which apply to **Translink** Service:

(T)

- Channel Termination
- Channel Mileage

1. Channel Termination

The Channel Termination rate category provides for the communications path between a customer designated premises and the Serving Wire Center. Included as part of the Channel Termination is a standard channel interface arrangement which defines the technical characteristics associated with the type of facilities to which the service is to be connected at the point of termination (POT) and the type of signaling capability if any. The signaling capability itself is provided as a part of this rate category. One Channel Termination charge applies per customer designated premises at which the channel is terminated. Channel Termination charges are set forth in 6.1.7.A.

2. Channel Mileage

The Channel Mileage rate category provides for the end office equipment and the transmission channel between the Serving Wire Centers associated with two customer designated premises, between a Serving Wire Center associated with a customer designated premises and a Company hub, or between two Telephone Company hubs. Channel Mileage rates are made up of the Channel Mileage Facility (per mile) rate and the Channel Mileage Termination (fixed) rate. Channel Mileage charges are set forth in 6.1.7.B.

ISSUED:  
September 13, 2006

BY: Darlene N. Terry  
Manager - Tariffs  
5454 W. 110th Street  
Overland Park, KS 66211

EFFECTIVE:  
October 13, 2006

PRIVATE LINE SERVICE

6.1 Link Services (Cont'd)

6.1.5 Rate Categories (Cont'd)

B. Translink® Service

There are two rate categories which apply to Translink® Service:

- Channel Termination
- Channel Mileage

1. Channel Termination

The Channel Termination rate category provides for the communications path between a customer designated premises and the Serving Wire Center. Included as part of the Channel Termination is a standard channel interface arrangement which defines the technical characteristics associated with the type of facilities to which the service is to be connected at the point of termination (POT) and the type of signaling capability if any. The signaling capability itself is provided as a part of this rate category. One Channel Termination charge applies per customer designated premises at which the channel is terminated. Channel Termination charges are set forth in 6.1.7.A.

2. Channel Mileage

The Channel Mileage rate category provides for the end office equipment and the transmission channel between the Serving Wire Centers associated with two customer designated premises, between a Serving Wire Center associated with a customer designated premises and a Company hub, or between two Telephone Company hubs. Channel Mileage rates are made up of the Channel Mileage Facility (per mile) rate and the Channel Mileage Termination (fixed) rate. Channel Mileage charges are set forth in 6.1.7.B.

ISSUED:  
December 10, 2003

BY: Richard D. Lawson  
State Executive, External Affairs  
319 Madison  
Jefferson City, MO 65101

EFFECTIVE:  
January 10, 2004

**Cancelled**

October 13, 2006

Missouri Public  
Service Commission

**Filed**

Missouri Public  
Service Commission

PRIVATE LINE SERVICE

6.1 Link Services (Cont'd)

6.1.5 Rate Categories (Cont'd)

B. **Translink** Service (Cont'd)

(T)

2. Channel Mileage (Cont'd)

(a) Channel Mileage Facility (Per Mile)

The Channel Mileage Facility (per mile) rate recovers the cost for the transmission path, which extends between the Telephone Company Serving Wire Centers and/or hub(s) includes primarily outside plant used to provide the facility.

(b) Channel Mileage Termination (Fixed)

The Channel Mileage Termination (fixed) rate recovers the cost for end office equipment associated with terminating the facility (i.e., basic circuit equipment and terminations at Serving Wire Centers). The Telephone Company applies a 50% billing percentage to the channel mileage fixed rate on jointly owned circuits, and applies 100% on wholly owned circuits. When the Channel Mileage Facility (per mile) is zero (i.e., collocated Serving Wire Centers), neither the Channel Mileage Facility (per mile) rate nor the Channel Mileage Termination (fixed) rate will apply.

ISSUED:  
September 13, 2006

BY: Darlene N. Terry  
Manager - Tariffs  
5454 W. 110th Street  
Overland Park, KS 66211

EFFECTIVE:  
October 13, 2006

PRIVATE LINE SERVICE

6.1 Link Services (Cont'd)

6.1.5 Rate Categories (Cont'd)

B. Translink® Service (Cont'd)

2. Channel Mileage (Cont'd)

(a) Channel Mileage Facility (Per Mile)

The Channel Mileage Facility (per mile) rate recovers the cost for the transmission path, which extends between the Telephone Company Serving Wire Centers and/or hub(s) includes primarily outside plant used to provide the facility.

(b) Channel Mileage Termination (Fixed)

The Channel Mileage Termination (fixed) rate recovers the cost for end office equipment associated with terminating the facility (i.e., basic circuit equipment and terminations at Serving Wire Centers). The Telephone Company applies a 50% billing percentage to the channel mileage fixed rate on jointly owned circuits, and applies 100% on wholly owned circuits. When the Channel Mileage Facility (per mile) is zero (i.e., collocated Serving Wire Centers), neither the Channel Mileage Facility (per mile) rate nor the Channel Mileage Termination (fixed) rate will apply.

ISSUED:  
December 10, 2003

BY: Richard D. Lawson  
State Executive, External Affairs  
319 Madison  
Jefferson City, MO 65101

EFFECTIVE:  
January 10, 2004

**Cancelled**

October 13, 2006

Missouri Public  
Service Commission

**Filed**

Missouri Public  
Service Commission

PRIVATE LINE SERVICE

6.1 Link Services (Cont'd)

6.1.5 Rate Categories (Cont'd)

C. **Lightlink** Service

(T)

There are two rate categories which apply to **Lightlink** Service:

(T)

- Channel Termination
- Channel Mileage

1. Channel Termination

The Channel Termination rate category provides for the communications path between a customer designated premises and the Serving Wire Center. Included as part of the Channel Termination is a standard channel interface arrangement which defines the technical characteristics associated with the type of facilities to which the service is to be connected at the point of termination (POT) and the type of signaling capability if any. The signaling capability itself is provided as a part of this rate category. One Channel Termination charge applies per customer designated premises at which the channel is terminated. The charges applicable to the Channel Termination vary based on distance, as set forth in 6.1.7.A following.

2. Channel Mileage

The Channel Mileage rate category provides for the end office equipment and the transmission channel between the Serving Wire Centers associated with two customer designated premises, between a Serving Wire Center associated with a customer designated premises and a Telephone Company hub, or between two Company hubs. Channel Mileage rates are made up of the Channel Mileage Facility (per mile) rate and the Channel Mileage Termination (fixed) rate. Channel Mileage charges are set forth in 6.1.7.B.

ISSUED:  
September 13, 2006

BY: Darlene N. Terry  
Manager - Tariffs  
5454 W. 110th Street  
Overland Park, KS 66211

EFFECTIVE:  
October 13, 2006

PRIVATE LINE SERVICE

6.1 Link Services (Cont'd)

6.1.5 Rate Categories (Cont'd)

C. Lightlink<sup>SM</sup> Service

There are two rate categories which apply to Lightlink<sup>SM</sup> Service:

- Channel Termination
- Channel Mileage

1. Channel Termination

The Channel Termination rate category provides for the communications path between a customer designated premises and the Serving Wire Center. Included as part of the Channel Termination is a standard channel interface arrangement which defines the technical characteristics associated with the type of facilities to which the service is to be connected at the point of termination (POT) and the type of signaling capability if any. The signaling capability itself is provided as a part of this rate category. One Channel Termination charge applies per customer designated premises at which the channel is terminated. The charges applicable to the Channel Termination vary based on distance, as set forth in 6.1.7.A following.

2. Channel Mileage

The Channel Mileage rate category provides for the end office equipment and the transmission channel between the Serving Wire Centers associated with two customer designated premises, between a Serving Wire Center associated with a customer designated premises and a Telephone Company hub, or between two Company hubs. Channel Mileage rates are made up of the Channel Mileage Facility (per mile) rate and the Channel Mileage Termination (fixed) rate. Channel Mileage charges are set forth in 6.1.7.B.

ISSUED:  
December 10, 2003

BY: Richard D. Lawson  
State Executive, External Affairs  
319 Madison  
Jefferson City, MO 65101

EFFECTIVE:  
January 10, 2004

**Cancelled**

October 13, 2006

Missouri Public  
Service Commission

**Filed**

Missouri Public  
Service Commission

Embarq Missouri, Inc.  
d/b/a Embarq

Section 6  
First Revised Page 20  
Cancels Original Page 20

PRIVATE LINE SERVICE

6.1 Link Services (Cont'd)

6.1.5 Rate Categories (Cont'd)

C. **Lightlink** Service (Cont'd)

(T)

2. Channel Mileage (Cont'd)

(a) Channel Mileage Facility (Per Mile)

The Channel Mileage Facility (per mile) rate recovers the cost for the transmission path, which extends between the Telephone Company Serving Wire Centers and/or hub(s) includes primarily outside plant used to provide the facility.

(b) Channel Mileage Termination (Fixed)

The Channel Mileage Termination (fixed) rate recovers the cost for end office equipment associated with terminating the facility (i.e., basic circuit equipment and terminations at Serving Wire Centers). The Telephone Company applies a 50% billing percentage to the channel mileage fixed rate on jointly owned circuits, and applies 100% on wholly owned circuits. When the Channel Mileage Facility (per mile) is zero (i.e., collocated Serving Wire Centers), neither the Channel Mileage Facility (per mile) rate nor the Channel Mileage Termination (fixed) rate will apply.

ISSUED:  
September 13, 2006

BY: Darlene N. Terry  
Manager - Tariffs  
5454 W. 110th Street  
Overland Park, KS 66211

EFFECTIVE:  
October 13, 2006

PRIVATE LINE SERVICE

6.1 Link Services (Cont'd)

6.1.5 Rate Categories (Cont'd)

C. Lightlink<sup>SM</sup> Service (Cont'd)

2. Channel Mileage (Cont'd)

(a) Channel Mileage Facility (Per Mile)

The Channel Mileage Facility (per mile) rate recovers the cost for the transmission path, which extends between the Telephone Company Serving Wire Centers and/or hub(s) includes primarily outside plant used to provide the facility.

(b) Channel Mileage Termination (Fixed)

The Channel Mileage Termination (fixed) rate recovers the cost for end office equipment associated with terminating the facility (i.e., basic circuit equipment and terminations at Serving Wire Centers). The Telephone Company applies a 50% billing percentage to the channel mileage fixed rate on jointly owned circuits, and applies 100% on wholly owned circuits. When the Channel Mileage Facility (per mile) is zero (i.e., collocated Serving Wire Centers), neither the Channel Mileage Facility (per mile) rate nor the Channel Mileage Termination (fixed) rate will apply.

ISSUED:  
December 10, 2003

BY: Richard D. Lawson  
State Executive, External Affairs  
319 Madison  
Jefferson City, MO 65101

EFFECTIVE:  
January 10, 2004

**Cancelled**

October 13, 2006

Missouri Public  
Service Commission

**Filed**

Missouri Public  
Service Commission



## PRIVATE LINE SERVICE

6.1 Link Services (Cont'd)6.1.5 Rate Categories (Cont'd)D. Optional Features and Functions - Applicable to **Translink** and **Lightlink** Service (T)

Optional Features and Functions may be added to improve the quality or utility to meet the customer's specific communications requirements. These are not necessarily identifiable with specific equipment, but rather represent the end result in terms of performance characteristics, which may be obtained. These characteristics may be obtained by using various combinations of equipment. Optional Features and Functions that are available include the following:

## 1. Central Office Multiplexing

DS3 to DS1 - An arrangement that converts a 44.736 Mbps channel to 28 DS1 channels using digital time division multiplexing. Central Office Multiplexing is not available at the customer's premises.

DS1 to DS0 - An arrangement that converts a 1.544 Mbps channel to twenty-four (24) 64.0 Kbps channels utilizing digital time division multiplexing. Central Office Multiplexing is not available at the customer's premises.

## 2. Clear Channel Capability (CCC)

Clear Channel Capability (CCC) is an arrangement that alters a DS1/1.544 Mbps signal with unconstrained information bits to meet pulse density requirements outlined in Technical Reference Publications GR-54 and GR-342. This will allow a customer to transport an all zero octet over a DS1/1.544 Mbps channel providing an available combined maximum 1.536 Mbps data rate. This arrangement requires the customer signal at the channel interface to conform to Bipolar with 8 Zero Substitution (B8ZS) line code as described in Technical Reference Publications GR-54 and GR-342.

CCC is provided on DS1/1.544 Mbps channels of a **Translink** and **Lightlink** Service facility between two customer designated premises and is subject to the availability of facilities. This optional feature may be ordered at the same time the Translink and Lightlink Service channel is ordered, or it may be ordered as an additional feature of an existing Translink and Lightlink Service channel. (T)

ISSUED:  
September 13, 2006

BY: Darlene N. Terry  
Manager - Tariffs  
5454 W. 110th Street  
Overland Park, KS 66211

EFFECTIVE:  
October 13, 2006

## PRIVATE LINE SERVICE

6.1 Link Services (Cont'd)6.1.5 Rate Categories (Cont'd)D. Optional Features and Functions - Applicable to Translink® and Lightlink<sup>SM</sup> Service

Optional Features and Functions may be added to improve the quality or utility to meet the customer's specific communications requirements. These are not necessarily identifiable with specific equipment, but rather represent the end result in terms of performance characteristics, which may be obtained. These characteristics may be obtained by using various combinations of equipment. Optional Features and Functions that are available include the following:

## 1. Central Office Multiplexing

DS3 to DS1 - An arrangement that converts a 44.736 Mbps channel to 28 DS1 channels using digital time division multiplexing. Central Office Multiplexing is not available at the customer's premises.

DS1 to DS0 - An arrangement that converts a 1.544 Mbps channel to twenty-four (24) 64.0 Kbps channels utilizing digital time division multiplexing. Central Office Multiplexing is not available at the customer's premises.

## 2. Clear Channel Capability (CCC)

Clear Channel Capability (CCC) is an arrangement that alters a DS1/1.544 Mbps signal with unconstrained information bits to meet pulse density requirements outlined in Technical Reference Publications GR-54 and GR-342. This will allow a customer to transport an all zero octet over a DS1/1.544 Mbps channel providing an available combined maximum 1.536 Mbps data rate. This arrangement requires the customer signal at the channel interface to conform to Bipolar with 8 Zero Substitution (B8ZS) line code as described in Technical Reference Publications GR-54 and GR-342.

CCC is provided on DS1/1.544 Mbps channels of a Translink® and Lightlink<sup>SM</sup> Service facility between two customer designated premises and is subject to the availability of facilities. This optional feature may be ordered at the same time the Translink and Lightlink Service channel is ordered, or it may be ordered as an additional feature of an existing Translink and Lightlink Service channel.

ISSUED:  
December 10, 2003

BY: Richard D. Lawson  
State Executive, External Affairs  
319 Madison  
Jefferson City, MO 65101

EFFECTIVE:  
January 10, 2004

**Cancelled**

October 13, 2006

Missouri Public  
Service Commission

**Filed**

Missouri Public  
Service Commission

PRIVATE LINE SERVICE

6.1 Link Services (Cont'd)

6.1.5 Rate Categories (Cont'd)

D. Optional Features and Functions - Applicable to **Translink** and **Lightlink** Service (Cont'd) (T)

3. Extended Superframe Format (ESF)

The ESF optional feature is available at suitably equipped end offices, and passes a customer provided framing format for 1.544 Mbps service. ESF extends the customer's 1.544 Mbps framing structure from twelve (12) to twenty-four (24) frames and divides the 8 Kbps 193rd bit position pattern into three distinct functionalities: 2 Kbps for frame synchronization, 2 Kbps for cyclic redundancy checking, and 4 Kbps used primarily for performance monitoring information.

4. Multiplexed Service Connection

For **Translink** Service, a Multiplexed Service Connection is an arrangement that allows one DS0 channel of a multiplexed Telephone Company service to be connected to one DS0 channel with like signaling of another Telephone Company service. A Multiplexed Service Connection will be provided at all Telephone Company locations where Central Office Multiplexing is performed. (T)

For **Lightlink** Service, a Multiplexed Service Connection is an arrangement that allows one DS1 channel of a multiplexed Telephone Company service to be connected to one DS1 channel with like signaling of another Telephone Company service. For example, the lesser speed may be an ISDN-PRI DS1 channel connected between a multiplexed DS3 service. A Multiplexed Service Connection will be provided at all Telephone Company locations where Central Office Multiplexing is performed. (T)

ISSUED:  
September 13, 2006

BY: Darlene N. Terry  
Manager - Tariffs  
5454 W. 110th Street  
Overland Park, KS 66211

EFFECTIVE:  
October 13, 2006

PRIVATE LINE SERVICE

6.1 Link Services (Cont'd)

6.1.5 Rate Categories (Cont'd)

D. Optional Features and Functions - Applicable to Translink® and Lightlink<sup>SM</sup> Service (Cont'd)

3. Extended Superframe Format (ESF)

The ESF optional feature is available at suitably equipped end offices, and passes a customer provided framing format for 1.544 Mbps service. ESF extends the customer's 1.544 Mbps framing structure from twelve (12) to twenty-four (24) frames and divides the 8 Kbps 193rd bit position pattern into three distinct functionalities: 2 Kbps for frame synchronization, 2 Kbps for cyclic redundancy checking, and 4 Kbps used primarily for performance monitoring information.

4. Multiplexed Service Connection

For Translink® Service, a Multiplexed Service Connection is an arrangement that allows one DS0 channel of a multiplexed Telephone Company service to be connected to one DS0 channel with like signaling of another Telephone Company service. A Multiplexed Service Connection will be provided at all Telephone Company locations where Central Office Multiplexing is performed.

For Lightlink<sup>SM</sup> Service, a Multiplexed Service Connection is an arrangement that allows one DS1 channel of a multiplexed Telephone Company service to be connected to one DS1 channel with like signaling of another Telephone Company service. For example, the lesser speed may be an ISDN-PRI DS1 channel connected between a multiplexed DS3 service. A Multiplexed Service Connection will be provided at all Telephone Company locations where Central Office Multiplexing is performed.

ISSUED:  
December 10, 2003

BY: Richard D. Lawson  
State Executive, External Affairs  
319 Madison  
Jefferson City, MO 65101

EFFECTIVE:  
January 10, 2004

**Cancelled**

October 13, 2006

Missouri Public  
Service Commission

**Filed**

Missouri Public  
Service Commission

PRIVATE LINE SERVICE

6.1 Link Services (Cont'd)

6.1.6 Application Of Rates

A. **Digilink** Service

(T)

1. Each **Digilink** Service facility may be comprised of two or more Channel Terminations. Where both customer premises are served by the same Serving Wire Center, the service will consist of two or more Channel Terminations. Where each customer premises is served by different Serving Wire Centers, the service will consist of two or more Channel Terminations, one Channel Mileage Termination (fixed) and the Channel Mileage Facility (per mile) between Serving Wire Centers and/or hub(s). (T)
2. Intraexchange channels furnished between Company central offices will be charged at rates based on airline distance between the central offices. Interexchange channels will be charged at rates based on airline distance between Company central offices. Fractional mileage will be rounded up to the next full mile. The mileage measurement is determined by utilizing exchange maps and mileage tables located in designated Telephone Company offices for such purposes.
3. Whenever facilities are provided jointly by the Telephone Company and another telephone company, the regulations, rates and charges of the other telephone company shall apply for the equipment and facilities furnished by the other telephone company for use in connection with Digilink Service. The Telephone Company applies a 50% billing percentage to the Channel Mileage Termination (fixed) rate on jointly owned circuits, and applies 100% on wholly owned circuits. When the Channel Mileage Facility (per mile) is zero (i.e., collocated Serving Wire Centers), neither the Channel Mileage Facility (per mile) rate nor the Channel Mileage Termination (fixed) rate will apply.

ISSUED:  
September 13, 2006

BY: Darlene N. Terry  
Manager - Tariffs  
5454 W. 110th Street  
Overland Park, KS 66211

EFFECTIVE:  
October 13, 2006

PRIVATE LINE SERVICE

6.1 Link Services (Cont'd)

6.1.6 Application Of Rates

A. Digilink® Service

1. Each Digilink® Service facility may be comprised of two or more Channel Terminations. Where both customer premises are served by the same Serving Wire Center, the service will consist of two or more Channel Terminations. Where each customer premises is served by different Serving Wire Centers, the service will consist of two or more Channel Terminations, one Channel Mileage Termination (fixed) and the Channel Mileage Facility (per mile) between Serving Wire Centers and/or hub(s).
2. Intraexchange channels furnished between Company central offices will be charged at rates based on airline distance between the central offices. Interexchange channels will be charged at rates based on airline distance between Company central offices. Fractional mileage will be rounded up to the next full mile. The mileage measurement is determined by utilizing exchange maps and mileage tables located in designated Telephone Company offices for such purposes.
3. Whenever facilities are provided jointly by the Telephone Company and another telephone company, the regulations, rates and charges of the other telephone company shall apply for the equipment and facilities furnished by the other telephone company for use in connection with Digilink Service. The Telephone Company applies a 50% billing percentage to the Channel Mileage Termination (fixed) rate on jointly owned circuits, and applies 100% on wholly owned circuits. When the Channel Mileage Facility (per mile) is zero (i.e., collocated Serving Wire Centers), neither the Channel Mileage Facility (per mile) rate nor the Channel Mileage Termination (fixed) rate will apply.

ISSUED:  
December 10, 2003

BY: Richard D. Lawson  
State Executive, External Affairs  
319 Madison  
Jefferson City, MO 65101

EFFECTIVE:  
January 10, 2004

**Cancelled**

October 13, 2006

Missouri Public  
Service Commission

**Filed**

Missouri Public  
Service Commission

Embarq Missouri, Inc.  
d/b/a Embarq

Section 6  
Second Revised Page 24  
Cancels First Revised Page 24

PRIVATE LINE SERVICE

6.1 Link Services (Cont'd)

6.1.6 Application Of Rates (Cont'd)

A. Digilink Service (Cont'd)

4. Data Amplification provides for data transmission when the customer is located beyond the normal range for high speed digital data service. Local channel terminations greater **than three** (3) miles in length for 56 Kbps and 64 Kbps service may require circuit repeaters and associated equipment be installed to regenerate the digital signal in order for accurate and acceptable data transmission to occur. The distances given are an indication of the potential requirement for Data Amplification. The actual distance is dependent on decibel (db) loss and not just physical loop length and is a function of the specific Telephone Company cable between the serving wire center and the customer's location. Applications requiring Data Amplification may also require special construction charges, Construction and Installation Charges, as specified in Section 8 of the P.S.C. MO No. 22 General Exchange Tariff. (C)
5. One Central Office Bridging Capability charge applies per port. When more than one Serving Wire Center is involved, the origin of the bridge(s) will dictate if there are additional interoffice transport charges (i.e., Channel Mileage Facility, Per Mileage). Refer to diagrams in 6.1.2.A.7 preceding.

ISSUED:  
January 20, 2009

BY: Darlene N. Terry  
Manager - Tariffs  
5454 W. 110th Street  
Overland Park, Kansas 66211

EFFECTIVE:  
February 1, 2009

CANCELLED  
October 19, 2009  
Missouri Public  
Service Commission  
TN-2010-0086; JI-2010-0157

FILED  
Missouri Public  
Service Commission  
JI-2009-0529

PRIVATE LINE SERVICE

6.1 Link Services (Cont'd)

6.1.6 Application Of Rates (Cont'd)

A. **Digilink** Service (Cont'd)

(T)

4. Data Amplification provides for data transmission when the customer is located beyond the normal range for high speed digital data service. Local channel terminations greater than five (5) cable route miles in length for 19.2 Kbps service or three (3) miles in length for 56 Kbps and 64 Kbps service may require circuit repeaters and associated equipment be installed to regenerate the digital signal in order for accurate and acceptable data transmission to occur. The distances given are an indication of the potential requirement for Data Amplification. The actual distance is dependent on decibel (db) loss and not just physical loop length and is a function of the specific Telephone Company cable between the serving wire center and the customer's location. Applications requiring Data Amplification may also require special construction charges, Construction and Installation Charges, as specified in Section 8 of the P.S.C. MO No. 22 General Exchange Tariff.
5. One Central Office Bridging Capability charge applies per port. When more than one Serving Wire Center is involved, the origin of the bridge(s) will dictate if there are additional interoffice transport charges (i.e., Channel Mileage Facility, Per Mileage). Refer to diagrams in 6.1.2.A.7 preceding.

ISSUED:  
September 13, 2006

BY: Darlene N. Terry  
Manager - Tariffs  
5454 W. 110th Street  
Overland Park, KS 66211

EFFECTIVE:  
October 13, 2006

CANCELLED  
February 1, 2009  
Missouri Public  
Service Commission  
JI-2009-0529

**Filed**  
Missouri Public  
Service Commission



PRIVATE LINE SERVICE

6.1 Link Services (Cont'd)

6.1.6 Application Of Rates (Cont'd)

A. Digilink® Service (Cont'd)

4. Data Amplification provides for data transmission when the customer is located beyond the normal range for high speed digital data service. Local channel terminations greater than five (5) cable route miles in length for 19.2 Kbps service or three (3) miles in length for 56 Kbps and 64 Kbps service may require circuit repeaters and associated equipment be installed to regenerate the digital signal in order for accurate and acceptable data transmission to occur. The distances given are an indication of the potential requirement for Data Amplification. The actual distance is dependent on decibel (db) loss and not just physical loop length and is a function of the specific Telephone Company cable between the serving wire center and the customer's location. Applications requiring Data Amplification may also require special construction charges, Construction and Installation Charges, as specified in Section 8 of the P.S.C. MO No. 22 General Exchange Tariff.
5. One Central Office Bridging Capability charge applies per port. When more than one Serving Wire Center is involved, the origin of the bridge(s) will dictate if there are additional interoffice transport charges (i.e., Channel Mileage Facility, Per Mileage). Refer to diagrams in 6.1.2.A.7 preceding.

ISSUED:  
December 10, 2003

BY: Richard D. Lawson  
State Executive, External Affairs  
319 Madison  
Jefferson City, MO 65101

EFFECTIVE:  
January 10, 2004

**Cancelled**

October 13, 2006

Missouri Public  
Service Commission

**Filed**

Missouri Public  
Service Commission

Embarq Missouri, Inc.  
d/b/a Embarq

Section 6  
First Revised Page 25  
Cancels Original Page 25

PRIVATE LINE SERVICE

6.1 Link Services (Cont'd)

6.1.6 Application Of Rates (Cont'd)

B. **Translink** Service

(T)

1. Each **Translink** Service facility is comprised of two Channel Terminations. Where both customer premises are served by the same Serving Wire Center, the service will consist of two Channel Terminations. Where each customer premises is served by different Serving Wire Centers, the service will consist of two Channel Terminations, one Channel Mileage Termination (fixed) and the Channel Mileage Facility (per mile) between Serving Wire Centers and/or hub(s). (T)
2. Intraexchange channels furnished between Telephone Company central offices will be charged at rates based on airline distance between the central offices. Interexchange channels will be charged at rates based on airline distance between Telephone Company central offices. Fractional mileage will be rounded up to the next full mile. The mileage measurement is determined by utilizing exchange maps and mileage tables located in designated Telephone Company offices for such purposes.
3. Whenever facilities are provided jointly by the Telephone Company and another telephone company, the regulations, rates and charges of the other telephone company shall apply for the equipment and facilities furnished by the other telephone company for use in connection with Translink Service. The Telephone Company applies a 50% billing percentage to the Channel Mileage Termination (fixed) rate on jointly owned circuits, and applies 100% on wholly owned circuits. When the Channel Mileage Facility (per mile) is zero (i.e., collocated Serving Wire Centers), neither the Channel Mileage Facility (per mile) rate nor the Channel Mileage Termination (fixed) rate will apply.

ISSUED:  
September 13, 2006

BY: Darlene N. Terry  
Manager - Tariffs  
5454 W. 110th Street  
Overland Park, KS 66211

EFFECTIVE:  
October 13, 2006

PRIVATE LINE SERVICE

6.1 Link Services (Cont'd)

6.1.6 Application Of Rates (Cont'd)

B. Translink® Service

1. Each Translink® Service facility is comprised of two Channel Terminations. Where both customer premises are served by the same Serving Wire Center, the service will consist of two Channel Terminations. Where each customer premises is served by different Serving Wire Centers, the service will consist of two Channel Terminations, one Channel Mileage Termination (fixed) and the Channel Mileage Facility (per mile) between Serving Wire Centers and/or hub(s).
2. Intraexchange channels furnished between Telephone Company central offices will be charged at rates based on airline distance between the central offices. Interexchange channels will be charged at rates based on airline distance between Telephone Company central offices. Fractional mileage will be rounded up to the next full mile. The mileage measurement is determined by utilizing exchange maps and mileage tables located in designated Telephone Company offices for such purposes.
3. Whenever facilities are provided jointly by the Telephone Company and another telephone company, the regulations, rates and charges of the other telephone company shall apply for the equipment and facilities furnished by the other telephone company for use in connection with Translink Service. The Telephone Company applies a 50% billing percentage to the Channel Mileage Termination (fixed) rate on jointly owned circuits, and applies 100% on wholly owned circuits. When the Channel Mileage Facility (per mile) is zero (i.e., collocated Serving Wire Centers), neither the Channel Mileage Facility (per mile) rate nor the Channel Mileage Termination (fixed) rate will apply.

ISSUED:  
December 10, 2003

BY: Richard D. Lawson  
State Executive, External Affairs  
319 Madison  
Jefferson City, MO 65101

EFFECTIVE:  
January 10, 2004

**Cancelled**

October 13, 2006

Missouri Public  
Service Commission

**Filed**

Missouri Public  
Service Commission

PRIVATE LINE SERVICE

6.1 Link Services (Cont'd)

6.1.6 Application Of Rates (Cont'd)

C. **Lightlink** Service

(T)

1. Each **Lightlink** Service facility may be comprised of one or two Channel Terminations. Where both customer premises are served by the same Serving Wire Center, the service will consist of two Channel Terminations. Where each customer premises is served by different Serving Wire Centers, the service will consist of two Channel Terminations, one Channel Mileage Termination (fixed) and the Channel Mileage Facility (per mile) between Serving Wire Centers and/or hub(s). Where one customer premises is involved, the Channel Termination of a lower bandwidth service can be replaced with a Lightlink Service Channel Termination. For example, the Channel Termination associated with ISDN-PRI Service, referred to as an ISDN-PRI Primary Rate Access Line, can be replaced with a Lightlink Service Channel Termination to connect the ISDN-PRI Service to the Serving Wire Center of the customer's designated premises. (T)
2. The Channel Termination rate element for Lightlink Service will vary based on distance. The mileage used to determine the monthly rate for Channel Terminations located outside a Telephone Company central office is the airline distance between the customer's designated premises and the Telephone Company's Serving Wire Center. The mileage measurement is determined by utilizing exchange maps and mileage tables located in designated Company offices for such purposes.
3. Intraexchange channels furnished between Telephone Company central offices will be charged at rates based on airline distance between the central offices. Interexchange channels will be charged at rates based on airline distance between Telephone Company central offices. Fractional mileage will be rounded up to the next full mile.
4. Whenever facilities are provided jointly by the Telephone Company and another telephone company, the regulations, rates and charges of the other telephone company shall apply for the equipment and facilities furnished by the other telephone company for use in connection with Lightlink Service. The Telephone Company applies a 50% billing percentage to the Channel Mileage Termination (fixed) rate on jointly owned circuits, and applies 100% on wholly owned circuits. When the Channel Mileage Facility (per mile) is zero (i.e., collocated Serving Wire Centers), neither the Channel Mileage Facility (per mile) rate nor the Channel Mileage Termination (fixed) rate will apply.

ISSUED:  
September 13, 2006

BY: Darlene N. Terry  
Manager - Tariffs  
5454 W. 110th Street  
Overland Park, KS 66211

EFFECTIVE:  
October 13, 2006

## PRIVATE LINE SERVICE

6.1 Link Services (Cont'd)6.1.6 Application Of Rates (Cont'd)C. Lightlink<sup>SM</sup> Service

1. Each Lightlink<sup>SM</sup> Service facility may be comprised of one or two Channel Terminations. Where both customer premises are served by the same Serving Wire Center, the service will consist of two Channel Terminations. Where each customer premises is served by different Serving Wire Centers, the service will consist of two Channel Terminations, one Channel Mileage Termination (fixed) and the Channel Mileage Facility (per mile) between Serving Wire Centers and/or hub(s). Where one customer premises is involved, the Channel Termination of a lower bandwidth service can be replaced with a Lightlink Service Channel Termination. For example, the Channel Termination associated with ISDN-PRI Service, referred to as an ISDN-PRI Primary Rate Access Line, can be replaced with a Lightlink Service Channel Termination to connect the ISDN-PRI Service to the Serving Wire Center of the customer's designated premises.
2. The Channel Termination rate element for Lightlink Service will vary based on distance. The mileage used to determine the monthly rate for Channel Terminations located outside a Telephone Company central office is the airline distance between the customer's designated premises and the Telephone Company's Serving Wire Center. The mileage measurement is determined by utilizing exchange maps and mileage tables located in designated Company offices for such purposes.
3. Intraexchange channels furnished between Telephone Company central offices will be charged at rates based on airline distance between the central offices. Interexchange channels will be charged at rates based on airline distance between Telephone Company central offices. Fractional mileage will be rounded up to the next full mile.
4. Whenever facilities are provided jointly by the Telephone Company and another telephone company, the regulations, rates and charges of the other telephone company shall apply for the equipment and facilities furnished by the other telephone company for use in connection with Lightlink Service. The Telephone Company applies a 50% billing percentage to the Channel Mileage Termination (fixed) rate on jointly owned circuits, and applies 100% on wholly owned circuits. When the Channel Mileage Facility (per mile) is zero (i.e., collocated Serving Wire Centers), neither the Channel Mileage Facility (per mile) rate nor the Channel Mileage Termination (fixed) rate will apply.

ISSUED:  
December 10, 2003BY: Richard D. Lawson  
State Executive, External Affairs  
319 Madison  
Jefferson City, MO 65101EFFECTIVE:  
January 10, 2004**Cancelled**

October 13, 2006

Missouri Public  
Service Commission**Filed**Missouri Public  
Service Commission

Embarq Missouri, Inc.  
d/b/a Embarq

Section 6  
Fourth Revised Page 27  
Cancels Third Revised Page 27

PRIVATE LINE SERVICE

6.1 Link Services (Cont'd)

6.1.7 Rates And Charges

	<u>Monthly Rate</u>	<u>Nonrecurring Charge Installation</u>	<u>Nonrecurring Charge Rearrangement</u>	
A. Channel Termination				
- Per Point of Termination				
1. Digilink Service				
				(D)
				(D)
56.0 Kbps, 64.0 Kbps				
Month to Month	\$132.80	\$345.00	\$150.00	
12 - 23 Months	120.75	345.00	150.00	
24 - 35 Months	118.50	345.00	150.00	
36 - 59 Months	<b>92.00</b>	345.00	150.00	( I )
60 - 84 Months	78.75	345.00	150.00	

ISSUED:  
January 20, 2009

BY: Darlene N. Terry  
Manager - Tariffs  
5454 W. 110th Street  
Overland Park, Kansas 66211

EFFECTIVE:  
February 1, 2009

CANCELLED  
October 19, 2009  
Missouri Public  
Service Commission  
TN-2010-0086; JI-2010-0157

FILED  
Missouri Public  
Service Commission  
JI-2009-0529

Embarq Missouri, Inc.  
d/b/a Embarq

Section 6  
Third Revised Page 27  
Cancels Second Revised Page 27

PRIVATE LINE SERVICE

6.1 Link Services (Cont'd)

6.1.7 Rates And Charges

	<u>Monthly Rate</u>	<u>Nonrecurring Charge Installation</u>	<u>Nonrecurring Charge Rearrangement</u>	
A. Channel Termination				
- Per Point of Termination				
1. Digilink Service				
19.2 Kbps				
Month to Month	<b>\$132.80</b>	\$345.00	\$150.00	(l)
12 - 23 Months	<b>120.75</b>	345.00	150.00	
24 - 35 Months	<b>118.50</b>	345.00	150.00	
36 - 59 Months	<b>84.00</b>	345.00	150.00	
60 - 84 Months	<b>78.75</b>	345.00	150.00	(l)
56.0 Kbps, 64.0 Kbps				
Month to Month	<b>132.80</b>	345.00	150.00	(l)
12 - 23 Months	<b>120.75</b>	345.00	150.00	
24 - 35 Months	<b>118.50</b>	345.00	150.00	
36 - 59 Months	<b>84.00</b>	345.00	150.00	
60 - 84 Months	<b>78.75</b>	345.00	150.00	(l)

ISSUED:  
December 3, 2007

BY: Darlene N. Terry  
Manager - Tariffs  
5454 W. 110th Street  
Overland Park, KS 66211

EFFECTIVE:  
January 30, 2008

CANCELLED  
February 1, 2009  
Missouri Public  
Service Commission  
JI-2009-0529

FILED  
Missouri Public  
Service Commission

Embarq Missouri, Inc.  
d/b/a Embarq

Section 6  
Second Revised Page 27  
Cancels First Revised Page 27

PRIVATE LINE SERVICE

6.1 Link Services (Cont'd)

6.1.7 Rates And Charges

	<u>Monthly Rate</u>	<u>Nonrecurring Charge Installation</u>	<u>Nonrecurring Charge Rearrangement</u>	
A. Channel Termination - Per Point of Termination				
1. Digilink Service				
19.2 Kbps				
Month to Month	<b>\$126.50</b>	\$345.00	\$150.00	(l)
12 - 23 Months	115.00	345.00	150.00	
24 - 35 Months	113.00	345.00	150.00	
36 - 59 Months	80.00	345.00	150.00	
60 - 84 Months	75.00	345.00	150.00	
56.0 Kbps, 64.0 Kbps				
Month to Month	<b>126.50</b>	345.00	150.00	(l)
12 - 23 Months	115.00	345.00	150.00	
24 - 35 Months	113.00	345.00	150.00	
36 - 59 Months	80.00	345.00	150.00	
60 - 84 Months	75.00	345.00	150.00	

ISSUED:  
December 1, 2006

BY: Darlene N. Terry  
Manager - Tariffs  
5454 W. 110th Street  
Overland Park, KS 66211

EFFECTIVE:  
January 15, 2007

CANCELLED  
January 30, 2008  
Missouri Public  
Service Commission

**Filed**  
Missouri Public  
Service Commission



Embarq Missouri, Inc.  
d/b/a Embarq

Section 6  
First Revised Page 27  
Cancels Original Page 27

PRIVATE LINE SERVICE

6.1 Link Services (Cont'd)

6.1.7 Rates And Charges

	<u>Monthly Rate</u>	<u>Nonrecurring Charge Installation</u>	<u>Nonrecurring Charge Rearrangement</u>	
A. Channel Termination				
- Per Point of Termination				
1. <b>Digilink Service</b> <span style="float: right;">(T)</span>				
19.2 Kbps				
Month to Month	\$121.00	\$345.00	\$150.00	
12 - 23 Months	115.00	345.00	150.00	
24 - 35 Months	113.00	345.00	150.00	
36 - 59 Months	80.00	345.00	150.00	
60 - 84 Months	75.00	345.00	150.00	
56.0 Kbps, 64.0 Kbps				
Month to Month	121.00	345.00	150.00	
12 - 23 Months	115.00	345.00	150.00	
24 - 35 Months	113.00	345.00	150.00	
36 - 59 Months	80.00	345.00	150.00	
60 - 84 Months	75.00	345.00	150.00	

ISSUED:  
September 13, 2006

BY: Darlene N. Terry  
Manager - Tariffs  
5454 W. 110th Street  
Overland Park, KS 66211

EFFECTIVE:  
October 13, 2006

**Cancelled**  
January 15, 2007  
Missouri Public  
Service Commission

**Filed**  
Missouri Public  
Service Commission

SPRINT MISSOURI, INC.  
d/b/a SPRINT

Section 6

Original Page 27

PRIVATE LINE SERVICE

6.1 Link Services (Cont'd)

6.1.7 Rates And Charges

	<u>Monthly Rate</u>	<u>Nonrecurring Charge Installation</u>	<u>Nonrecurring Charge Rearrangement</u>
A. Channel Termination			
- Per Point of Termination			
1. Digilink® Service			
19.2 Kbps			
Month to Month	\$121.00	\$345.00	\$150.00
12 - 23 Months	115.00	345.00	150.00
24 - 35 Months	113.00	345.00	150.00
36 - 59 Months	80.00	345.00	150.00
60 - 84 Months	75.00	345.00	150.00
56.0 Kbps, 64.0 Kbps			
Month to Month	121.00	345.00	150.00
12 - 23 Months	115.00	345.00	150.00
24 - 35 Months	113.00	345.00	150.00
36 - 59 Months	80.00	345.00	150.00
60 - 84 Months	75.00	345.00	150.00

ISSUED:  
December 10, 2003

BY: Richard D. Lawson  
State Executive, External Affairs  
319 Madison  
Jefferson City, MO 65101

EFFECTIVE:  
January 10, 2004

**Cancelled**

October 13, 2006

Missouri Public  
Service Commission

**Filed**

Missouri Public  
Service Commission

Embarq Missouri, Inc.  
d/b/a Embarq

Section 6  
Fourth Revised Page 28  
Cancels Third Revised Page 28

PRIVATE LINE SERVICE

6.1 Link Services (Cont'd)

6.1.7 Rates And Charges (Cont'd)

	<u>Monthly Rate</u>	<u>Nonrecurring Charge Installation</u>	<u>Nonrecurring Charge Rearrangement</u>
A. Channel Termination (Cont'd) - Per Point of Termination			
2. Translink Service			

(D)

(D)

1.544 Mbps			
Month to Month	\$205.80	\$422.00	\$200.00
12 - 23 Months	181.00	422.00	200.00
24 - 35 Months	177.00	422.00	200.00
36 - 59 Months	135.00	422.00	200.00
60 - 84 Months	115.00	422.00	200.00

ISSUED:  
January 20, 2009

BY: Darlene N. Terry  
Manager - Tariffs  
5454 W. 110th Street  
Overland Park, Kansas 66211

EFFECTIVE:  
February 1, 2009

CANCELLED  
October 19, 2009  
Missouri Public  
Service Commission  
TN-2010-0086; JI-2010-0157

FILED  
Missouri Public  
Service Commission  
JI-2009-0529

Embarq Missouri, Inc.  
d/b/a Embarq

Section 6  
Third Revised Page 28  
Cancels Second Revised Page 28

PRIVATE LINE SERVICE

6.1 Link Services (Cont'd)

6.1.7 Rates And Charges (Cont'd)

A.	<u>Monthly Rate</u>	<u>Nonrecurring Charge Installation</u>	<u>Nonrecurring Charge Rearrangement</u>	
Channel Termination (Cont'd) - Per Point of Termination				
2. Translink Service				
128 Kbps				
Month to Month	<b>\$164.85</b>	\$402.00	\$200.00	(I)
12 - 23 Months	<b>150.00</b>	402.00	200.00	
24 - 35 Months	<b>147.00</b>	402.00	200.00	
36 - 59 Months	<b>120.00</b>	402.00	200.00	
60 - 84 Months	<b>106.00</b>	402.00	200.00	(I)
256 Kbps				
Month to Month	167.00	402.00	200.00	
12 - 23 Months	152.00	402.00	200.00	
24 - 35 Months	149.00	402.00	200.00	
36 - 59 Months	120.00	402.00	200.00	
60 - 84 Months	106.00	402.00	200.00	
384 Kbps				
Month to Month	<b>185.00</b>	402.00	200.00	(I)
12 - 23 Months	<b>169.00</b>	402.00	200.00	
24 - 35 Months	<b>165.00</b>	402.00	200.00	
36 - 59 Months	<b>131.00</b>	402.00	200.00	
60 - 84 Months	<b>113.00</b>	402.00	200.00	(I)
512 Kbps				
Month to Month	<b>185.00</b>	402.00	200.00	(I)
12 - 23 Months	<b>169.00</b>	402.00	200.00	
24 - 35 Months	<b>165.00</b>	402.00	200.00	
36 - 59 Months	<b>131.00</b>	402.00	200.00	
60 - 84 Months	<b>113.00</b>	402.00	200.00	(I)
1.544 Mbps				
Month to Month	<b>205.80</b>	422.00	200.00	(I)
12 - 23 Months	181.00	422.00	200.00	
24 - 35 Months	177.00	422.00	200.00	
36 - 59 Months	135.00	422.00	200.00	
60 - 84 Months	115.00	422.00	200.00	

ISSUED:  
December 3, 2007

BY: Darlene N. Terry  
Manager - Tariffs  
5454 W. 110th Street  
Overland Park, KS 66211

EFFECTIVE:  
January 30, 2008

CANCELLED  
February 1, 2009  
Missouri Public  
Service Commission  
JI-2009-0529

FILED  
Missouri Public  
Service Commission

Embarq Missouri, Inc.  
d/b/a Embarq

Section 6  
Second Revised Page 28  
Cancels First Revised Page 28

PRIVATE LINE SERVICE

6.1 Link Services (Cont'd)

6.1.7 Rates And Charges (Cont'd)

	<u>Monthly Rate</u>	<u>Nonrecurring Charge Installation</u>	<u>Nonrecurring Charge Rearrangement</u>	
A. Channel Termination (Cont'd)				
- Per Point of Termination				
2. Translink Service				
128 Kbps				
Month to Month	<b>\$157.00</b>	\$402.00	\$200.00	(I)
12 - 23 Months	143.00	402.00	200.00	
24 - 35 Months	140.00	402.00	200.00	
36 - 59 Months	115.00	402.00	200.00	
60 - 84 Months	104.00	402.00	200.00	
256 Kbps				
Month to Month	<b>167.00</b>	402.00	200.00	(I)
12 - 23 Months	152.00	402.00	200.00	
24 - 35 Months	149.00	402.00	200.00	
36 - 59 Months	120.00	402.00	200.00	
60 - 84 Months	106.00	402.00	200.00	
384 Kbps				
Month to Month	<b>177.00</b>	402.00	200.00	(I)
12 - 23 Months	162.00	402.00	200.00	
24 - 35 Months	158.00	402.00	200.00	
36 - 59 Months	125.00	402.00	200.00	
60 - 84 Months	108.00	402.00	200.00	
512 Kbps				
Month to Month	<b>182.00</b>	402.00	200.00	(I)
12 - 23 Months	166.00	402.00	200.00	
24 - 35 Months	163.00	402.00	200.00	
36 - 59 Months	130.00	402.00	200.00	
60 - 84 Months	110.00	402.00	200.00	
1.544 Mbps				
Month to Month	<b>196.00</b>	422.00	200.00	(I)
12 - 23 Months	181.00	422.00	200.00	
24 - 35 Months	177.00	422.00	200.00	
36 - 59 Months	135.00	422.00	200.00	
60 - 84 Months	115.00	422.00	200.00	

ISSUED:  
December 1, 2006

BY: Darlene N. Terry  
Manager - Tariffs  
5454 W. 110th Street  
Overland Park, KS 66211

EFFECTIVE:  
January 15, 2007

CANCELLED  
January 30, 2008  
Missouri Public  
Service Commission

**Filed**  
Missouri Public  
Service Commission

PRIVATE LINE SERVICE

6.1 Link Services (Cont'd)

6.1.7 Rates And Charges (Cont'd)

A.	<u>Monthly Rate</u>	<u>Nonrecurring Charge Installation</u>	<u>Nonrecurring Charge Rearrangement</u>	
Channel Termination (Cont'd)				
- Per Point of Termination				
2.	<b>Translink Service</b>			(T)
128 Kbps				
	Month to Month	\$150.00	\$402.00	\$200.00
	12 - 23 Months	143.00	402.00	200.00
	24 - 35 Months	140.00	402.00	200.00
	36 - 59 Months	115.00	402.00	200.00
	60 - 84 Months	104.00	402.00	200.00
256 Kbps				
	Month to Month	160.00	402.00	200.00
	12 - 23 Months	152.00	402.00	200.00
	24 - 35 Months	149.00	402.00	200.00
	36 - 59 Months	120.00	402.00	200.00
	60 - 84 Months	106.00	402.00	200.00
384 Kbps				
	Month to Month	170.00	402.00	200.00
	12 - 23 Months	162.00	402.00	200.00
	24 - 35 Months	158.00	402.00	200.00
	36 - 59 Months	125.00	402.00	200.00
	60 - 84 Months	108.00	402.00	200.00
512 Kbps				
	Month to Month	175.00	402.00	200.00
	12 - 23 Months	166.00	402.00	200.00
	24 - 35 Months	163.00	402.00	200.00
	36 - 59 Months	130.00	402.00	200.00
	60 - 84 Months	110.00	402.00	200.00
1.544 Mbps				
	Month to Month	190.00	422.00	200.00
	12 - 23 Months	181.00	422.00	200.00
	24 - 35 Months	177.00	422.00	200.00
	36 - 59 Months	135.00	422.00	200.00
	60 - 84 Months	115.00	422.00	200.00

ISSUED:  
September 13, 2006

BY: Darlene N. Terry  
Manager - Tariffs  
5454 W. 110th Street  
Overland Park, KS 66211

EFFECTIVE:  
October 13, 2006

**Cancelled**  
January 15, 2007  
Missouri Public  
Service Commission

**Filed**  
Missouri Public  
Service Commission

PRIVATE LINE SERVICE

6.1 Link Services (Cont'd)

6.1.7 Rates And Charges (Cont'd)

	<u>Monthly Rate</u>	<u>Nonrecurring Charge Installation</u>	<u>Nonrecurring Charge Rearrangement</u>
A. Channel Termination (Cont'd) - Per Point of Termination			
2. Translink® Service			
128 Kbps			
Month to Month	\$150.00	\$402.00	\$200.00
12 - 23 Months	143.00	402.00	200.00
24 - 35 Months	140.00	402.00	200.00
36 - 59 Months	115.00	402.00	200.00
60 - 84 Months	104.00	402.00	200.00
256 Kbps			
Month to Month	160.00	402.00	200.00
12 - 23 Months	152.00	402.00	200.00
24 - 35 Months	149.00	402.00	200.00
36 - 59 Months	120.00	402.00	200.00
60 - 84 Months	106.00	402.00	200.00
384 Kbps			
Month to Month	170.00	402.00	200.00
12 - 23 Months	162.00	402.00	200.00
24 - 35 Months	158.00	402.00	200.00
36 - 59 Months	125.00	402.00	200.00
60 - 84 Months	108.00	402.00	200.00
512 Kbps			
Month to Month	175.00	402.00	200.00
12 - 23 Months	166.00	402.00	200.00
24 - 35 Months	163.00	402.00	200.00
36 - 59 Months	130.00	402.00	200.00
60 - 84 Months	110.00	402.00	200.00
1.544 Mbps			
Month to Month	190.00	422.00	200.00
12 - 23 Months	181.00	422.00	200.00
24 - 35 Months	177.00	422.00	200.00
36 - 59 Months	135.00	422.00	200.00
60 - 84 Months	115.00	422.00	200.00

ISSUED:  
December 10, 2003

BY: Richard D. Lawson  
State Executive, External Affairs  
319 Madison  
Jefferson City, MO 65101

EFFECTIVE:  
January 10, 2004

**Cancelled**

October 13, 2006

Missouri Public  
Service Commission

**Filed**

Missouri Public  
Service Commission

Embarq Missouri, Inc.  
d/b/a Embarq

Section 6  
First Revised Page 29  
Cancels Original Page 29

PRIVATE LINE SERVICE

6.1 Link Services (Cont'd)

6.1.7 Rates And Charges (Cont'd)

	<u>Monthly Rate</u>	<u>Nonrecurring Charge Installation</u>	<u>Nonrecurring Charge Rearrangement</u>
A. Channel Termination (Cont'd)			
- Per Point of Termination			
3. <b>Lightlink</b> Service (T)			
44.736 Mbps			
Month to Month <sup>1</sup>			
Within CO	\$1,495.00	N/A	\$250.00
0-3 miles	1,795.00	N/A	250.00
Over 3 miles	2,495.00	N/A	250.00
12 - 23 Months			
Within CO	1,195.00	\$900.00	250.00
0-3 miles	1,595.00	900.00	250.00
Over 3 miles	2,295.00	900.00	250.00
24 - 35 Months			
Within CO	1,095.00	800.00	250.00
0-3 miles	1,495.00	850.00	250.00
Over 3 miles	2,195.00	850.00	250.00
36 - 59 Months			
Within CO	1,045.00	700.00	250.00
0-3 miles	1,445.00	800.00	250.00
Over 3 miles	2,145.00	800.00	250.00
60 - 84 Months			
Within CO	945.00	500.00	250.00
0-3 miles	1,345.00	600.00	250.00
Over 3 miles	2,045.00	600.00	250.00

<sup>1</sup>Month-to-month rates are available only after the expiration of one of the Term Discount Plans.

ISSUED:  
September 13, 2006

BY: Darlene N. Terry  
Manager - Tariffs  
5454 W. 110th Street  
Overland Park, KS 66211

EFFECTIVE:  
October 13, 2006



PRIVATE LINE SERVICE

6.1 Link Services (Cont'd)

6.1.7 Rates And Charges (Cont'd)

	<u>Monthly Rate</u>	<u>Nonrecurring Charge Installation</u>	<u>Nonrecurring Charge Rearrangement</u>
A. Channel Termination (Cont'd)			
- Per Point of Termination			
3. Lightlink <sup>SM</sup> Service			
44.736 Mbps			
Month to Month <sup>1</sup>			
Within CO	\$1,495.00	N/A	\$250.00
0-3 miles	1,795.00	N/A	250.00
Over 3 miles	2,495.00	N/A	250.00
12 - 23 Months			
Within CO	1,195.00	\$900.00	250.00
0-3 miles	1,595.00	900.00	250.00
Over 3 miles	2,295.00	900.00	250.00
24 - 35 Months			
Within CO	1,095.00	800.00	250.00
0-3 miles	1,495.00	850.00	250.00
Over 3 miles	2,195.00	850.00	250.00
36 - 59 Months			
Within CO	1,045.00	700.00	250.00
0-3 miles	1,445.00	800.00	250.00
Over 3 miles	2,145.00	800.00	250.00
60 - 84 Months			
Within CO	945.00	500.00	250.00
0-3 miles	1,345.00	600.00	250.00
Over 3 miles	2,045.00	600.00	250.00

<sup>1</sup>Month-to-month rates are available only after the expiration of one of the Term Discount Plans.

ISSUED:  
December 10, 2003

BY: Richard D. Lawson  
State Executive, External Affairs  
319 Madison  
Jefferson City, MO 65101

EFFECTIVE:  
January 10, 2004

**Cancelled**

October 13, 2006

Missouri Public  
Service Commission

**Filed**

Missouri Public  
Service Commission

Embarq Missouri, Inc.  
d/b/a Embarq

Section 6  
Second Revised Page 30  
Cancels First Revised Page 30

PRIVATE LINE SERVICE

6.1 Link Services (Cont'd)

6.1.7 Rates And Charges (Cont'd)

	<u>Monthly Rate</u>	<u>Nonrecurring Charge</u>	
B. Channel Mileage			
1. Termination (Fixed) - Per Circuit			
(a) Digilink Service			
<b>56.0 Kbps, 64.0 Kbps</b>			(D)
Month to Month	\$35.00	\$0.00	
12 - 23 Months	34.50	0.00	
24 - 35 Months	34.00	0.00	
36 - 59 Months	34.00	0.00	
60 - 84 Months	33.00	0.00	

ISSUED:  
January 20, 2009

BY: Darlene N. Terry  
Manager - Tariffs  
5454 W. 110th Street  
Overland Park, Kansas 66211

EFFECTIVE:  
February 1, 2009

CANCELLED  
October 19, 2009  
Missouri Public  
Service Commission  
TN-2010-0086; JI-2010-0157

FILED  
Missouri Public  
Service Commission  
JI-2009-0529

Embarq Missouri, Inc.  
d/b/a Embarq

Section 6  
First Revised Page 30  
Cancels Original Page 30

PRIVATE LINE SERVICE

6.1 Link Services (Cont'd)

6.1.7 Rates And Charges (Cont'd)

	<u>Monthly Rate</u>	<u>Nonrecurring Charge</u>
B. Channel Mileage		
1. Termination (Fixed) - Per Circuit		
(a) <b>Digilink</b> Service (T)		
19.2 Kbps, 56.0 Kbps, 64.0 Kbps		
Month to Month	\$35.00	\$0.00
12 - 23 Months	34.50	0.00
24 - 35 Months	34.00	0.00
36 - 59 Months	34.00	0.00
60 - 84 Months	33.00	0.00

ISSUED:  
September 13, 2006

BY: Darlene N. Terry  
Manager - Tariffs  
5454 W. 110th Street  
Overland Park, KS 66211

EFFECTIVE:  
October 13, 2006

CANCELLED  
February 1, 2009  
Missouri Public  
Service Commission  
JI-2009-0529

**Filed**  
Missouri Public  
Service Commission

SPRINT MISSOURI, INC.  
d/b/a SPRINT

Section 6  
Original Page 30

PRIVATE LINE SERVICE

6.1 Link Services (Cont'd)

6.1.7 Rates And Charges (Cont'd)

	<u>Monthly Rate</u>	<u>Nonrecurring Charge</u>
B. Channel Mileage		
1. Termination (Fixed)		
- Per Circuit		
(a) Digilink® Service		
19.2 Kbps, 56.0 Kbps, 64.0 Kbps		
Month to Month	\$35.00	\$0.00
12 - 23 Months	34.50	0.00
24 - 35 Months	34.00	0.00
36 - 59 Months	34.00	0.00
60 - 84 Months	33.00	0.00

ISSUED:  
December 10, 2003

BY: Richard D. Lawson  
State Executive, External Affairs  
319 Madison  
Jefferson City, MO 65101

EFFECTIVE:  
January 10, 2004

**Cancelled**

October 13, 2006

Missouri Public  
Service Commission

**Filed**

Missouri Public  
Service Commission

Embarq Missouri, Inc.  
d/b/a Embarq

Section 6  
Third Revised Page 31  
Cancels Second Revised Page 31

PRIVATE LINE SERVICE

6.1 Link Services (Cont'd)

6.1.7 Rates And Charges (Cont'd)

	<u>Monthly Rate</u>	<u>Nonrecurring Charge</u>	
B. Channel Mileage (Cont'd)			
1. Termination (Fixed) (Cont'd) - Per Circuit			
(b) Translink Service			
			(D)
			(D)
1.544 Mbps			
Month to Month	<b>\$117.00</b>	\$0.00	( I )
12 - 23 Months	100.00	0.00	
24 - 35 Months	98.00	0.00	
36 - 59 Months	<b>85.00</b>	0.00	( I )
60 - 84 Months	64.00	0.00	

ISSUED:  
January 20, 2009

BY: Darlene N. Terry  
Manager - Tariffs  
5454 W. 110th Street  
Overland Park, Kansas 66211

EFFECTIVE:  
February 1, 2009

CANCELLED  
October 19, 2009  
Missouri Public  
Service Commission  
TN-2010-0086; JI-2010-0157

FILED  
Missouri Public  
Service Commission  
JI-2009-0529

Embarq Missouri, Inc.  
d/b/a Embarq

Section 6  
Second Revised Page 31  
Cancels First Revised Page 31

PRIVATE LINE SERVICE

6.1 Link Services (Cont'd)

6.1.7 Rates And Charges (Cont'd)

	<u>Monthly Rate</u>	<u>Nonrecurring Charge</u>	
B. Channel Mileage (Cont'd)			
1. Termination (Fixed) (Cont'd) - Per Circuit			
(b) Translink Service			
128 Kbps			
Month to Month	<b>\$75.60</b>	\$0.00	(l)
12 - 23 Months	<b>75.60</b>	0.00	
24 - 35 Months	<b>75.60</b>	0.00	
36 - 59 Months	<b>75.60</b>	0.00	
60 - 84 Months	<b>64.00</b>	0.00	(l)
256 Kbps			
Month to Month	82.00	0.00	
12 - 23 Months	82.00	0.00	
24 - 35 Months	82.00	0.00	
36 - 59 Months	<b>75.60</b>	0.00	(l)
60 - 84 Months	<b>65.00</b>	0.00	(l)
384 Kbps			
Month to Month	<b>96.00</b>	0.00	(l)
12 - 23 Months	<b>96.00</b>	0.00	
24 - 35 Months	<b>96.00</b>	0.00	
36 - 59 Months	<b>75.60</b>	0.00	
60 - 84 Months	<b>64.00</b>	0.00	(l)
512 Kbps			
Month to Month	105.00	0.00	
12 - 23 Months	100.00	0.00	
24 - 35 Months	98.00	0.00	
36 - 59 Months	<b>75.60</b>	0.00	(l)
60 - 84 Months	<b>64.00</b>	0.00	(l)
1.544 Mbps			
Month to Month	105.00	0.00	
12 - 23 Months	100.00	0.00	
24 - 35 Months	98.00	0.00	
36 - 59 Months	<b>75.60</b>	0.00	(l)
60 - 84 Months	<b>64.00</b>	0.00	(l)

ISSUED:  
December 3, 2007

BY: Darlene N. Terry  
Manager - Tariffs  
5454 W. 110th Street  
Overland Park, KS 66211

EFFECTIVE:  
January 30, 2008

CANCELLED  
February 1, 2009  
Missouri Public  
Service Commission  
JI-2009-0529

FILED  
Missouri Public  
Service Commission

Embarq Missouri, Inc.  
d/b/a Embarq

Section 6  
First Revised Page 31  
Cancels Original Page 31

PRIVATE LINE SERVICE

6.1 Link Services (Cont'd)

6.1.7 Rates And Charges (Cont'd)

	<u>Monthly Rate</u>	<u>Nonrecurring Charge</u>
B. Channel Mileage (Cont'd)		
1. Termination (Fixed) (Cont'd) - Per Circuit		
(b) <b>Translink Service</b> (T)		
128 Kbps		
Month to Month	\$72.00	\$0.00
12 - 23 Months	72.00	0.00
24 - 35 Months	72.00	0.00
36 - 59 Months	72.00	0.00
60 - 84 Months	61.00	0.00
256 Kbps		
Month to Month	82.00	0.00
12 - 23 Months	82.00	0.00
24 - 35 Months	82.00	0.00
36 - 59 Months	72.00	0.00
60 - 84 Months	61.00	0.00
384 Kbps		
Month to Month	92.00	0.00
12 - 23 Months	92.00	0.00
24 - 35 Months	92.00	0.00
36 - 59 Months	72.00	0.00
60 - 84 Months	61.00	0.00
512 Kbps		
Month to Month	105.00	0.00
12 - 23 Months	100.00	0.00
24 - 35 Months	98.00	0.00
36 - 59 Months	72.00	0.00
60 - 84 Months	61.00	0.00
1.544 Mbps		
Month to Month	105.00	0.00
12 - 23 Months	100.00	0.00
24 - 35 Months	98.00	0.00
36 - 59 Months	72.00	0.00
60 - 84 Months	61.00	0.00

ISSUED:  
September 13, 2006

BY: Darlene N. Terry  
Manager - Tariffs  
5454 W. 110th Street  
Overland Park, KS 66211

EFFECTIVE:  
October 13, 2006

CANCELLED  
January 30, 2008  
Missouri Public  
Service Commission

**Filed**  
Missouri Public  
Service Commission

SPRINT MISSOURI, INC.  
d/b/a SPRINT

Section 6

Original Page 31

PRIVATE LINE SERVICE

6.1 Link Services (Cont'd)

6.1.7 Rates And Charges (Cont'd)

	<u>Monthly Rate</u>	<u>Nonrecurring Charge</u>
B. Channel Mileage (Cont'd)		
1. Termination (Fixed) (Cont'd) - Per Circuit		
(b) Translink® Service		
128 Kbps		
Month to Month	\$72.00	\$0.00
12 - 23 Months	72.00	0.00
24 - 35 Months	72.00	0.00
36 - 59 Months	72.00	0.00
60 - 84 Months	61.00	0.00
256 Kbps		
Month to Month	82.00	0.00
12 - 23 Months	82.00	0.00
24 - 35 Months	82.00	0.00
36 - 59 Months	72.00	0.00
60 - 84 Months	61.00	0.00
384 Kbps		
Month to Month	92.00	0.00
12 - 23 Months	92.00	0.00
24 - 35 Months	92.00	0.00
36 - 59 Months	72.00	0.00
60 - 84 Months	61.00	0.00
512 Kbps		
Month to Month	105.00	0.00
12 - 23 Months	100.00	0.00
24 - 35 Months	98.00	0.00
36 - 59 Months	72.00	0.00
60 - 84 Months	61.00	0.00
1.544 Mbps		
Month to Month	105.00	0.00
12 - 23 Months	100.00	0.00
24 - 35 Months	98.00	0.00
36 - 59 Months	72.00	0.00
60 - 84 Months	61.00	0.00

ISSUED:  
December 10, 2003

BY: Richard D. Lawson  
State Executive, External Affairs  
319 Madison  
Jefferson City, MO 65101

EFFECTIVE:  
January 10, 2004

**Cancelled**

October 13, 2006

Missouri Public  
Service Commission

**Filed**

Missouri Public  
Service Commission



Embarq Missouri, Inc.  
d/b/a Embarq

Section 6  
First Revised Page 32  
Cancels Original Page 32

PRIVATE LINE SERVICE

6.1 Link Services (Cont'd)

6.1.7 Rates And Charges (Cont'd)

	<u>Monthly Rate</u>	<u>Nonrecurring Charge</u>
B. Channel Mileage (Cont'd)		
1. Termination (Fixed) (Cont'd) - Per Circuit		
(c) <b>Lightlink</b> Service (T)		
44.736 Mbps		
Month to Month <sup>1</sup>	\$675.00	N/A
12 - 23 Months	665.00	\$0.00
24 - 35 Months	655.00	0.00
36 - 59 Months	635.00	0.00
60 - 84 Months	615.00	0.00

<sup>1</sup>Month-to-month rates are available only after the expiration of one of the Term Discount Plans.

ISSUED:  
September 13, 2006

BY: Darlene N. Terry  
Manager - Tariffs  
5454 W. 110th Street  
Overland Park, KS 66211

EFFECTIVE:  
October 13, 2006

SPRINT MISSOURI, INC.  
d/b/a SPRINT

Section 6

Original Page 32

PRIVATE LINE SERVICE

6.1 Link Services (Cont'd)

6.1.7 Rates And Charges (Cont'd)

	<u>Monthly Rate</u>	<u>Nonrecurring Charge</u>
B. Channel Mileage (Cont'd)		
1. Termination (Fixed) (Cont'd) - Per Circuit		
(c) Lightlink <sup>SM</sup> Service		
44.736 Mbps		
Month to Month <sup>1</sup>	\$675.00	N/A
12 - 23 Months	665.00	\$0.00
24 - 35 Months	655.00	0.00
36 - 59 Months	635.00	0.00
60 - 84 Months	615.00	0.00

<sup>1</sup>Month-to-month rates are available only after the expiration of one of the Term Discount Plans.

ISSUED:  
December 10, 2003

BY: Richard D. Lawson  
State Executive, External Affairs  
319 Madison  
Jefferson City, MO 65101

EFFECTIVE:  
January 10, 2004

**Cancelled**

October 13, 2006

Missouri Public  
Service Commission

**Filed**

Missouri Public  
Service Commission

Embarq Missouri, Inc.  
d/b/a Embarq

Section 6  
Second Revised Page 33  
Cancels First Revised Page 33

PRIVATE LINE SERVICE

6.1 Link Services (Cont'd)

6.1.7 Rates And Charges (Cont'd)

	<u>Monthly Rate</u>	<u>Nonrecurring Charge</u>	
B. Channel Mileage (Cont'd)			
2. Facility (Per Mile)			
(a) Digilink Service			
<b>56.0 Kbps, 64.0 Kbps</b>			(D)
Month to Month	<b>\$3.00</b>	\$0.00	(1)
12 - 23 Months	2.50	0.00	
24 - 35 Months	2.45	0.00	
36 - 59 Months	2.40	0.00	
60 - 84 Months	2.30	0.00	

ISSUED:  
January 20, 2009

BY: Darlene N. Terry  
Manager - Tariffs  
5454 W. 110th Street  
Overland Park, Kansas 66211

EFFECTIVE:  
February 1, 2009

CANCELLED  
October 19, 2009  
Missouri Public  
Service Commission  
TN-2010-0086; JI-2010-0157

FILED  
Missouri Public  
Service Commission  
JI-2009-0529

Embarq Missouri, Inc.  
d/b/a Embarq

Section 6  
First Revised Page 33  
Cancels Original Page 33

PRIVATE LINE SERVICE

6.1 Link Services (Cont'd)

6.1.7 Rates And Charges (Cont'd)

B. Channel Mileage (Cont'd)

2. Facility (Per Mile)

(a) **Digilink** Service

(T)

19.2 Kbps, 56.0 Kbps, 64.0 Kbps

Month to Month

\$2.55

\$0.00

12 - 23 Months

2.50

0.00

24 - 35 Months

2.45

0.00

36 - 59 Months

2.40

0.00

60 - 84 Months

2.30

0.00

ISSUED:  
September 13, 2006

BY: Darlene N. Terry  
Manager - Tariffs  
5454 W. 110th Street  
Overland Park, KS 66211

EFFECTIVE:  
October 13, 2006

CANCELLED  
February 1, 2009  
Missouri Public  
Service Commission  
JI-2009-0529

**Filed**  
Missouri Public  
Service Commission

SPRINT MISSOURI, INC.  
d/b/a SPRINT

Section 6

Original Page 33

PRIVATE LINE SERVICE

6.1 Link Services (Cont'd)

6.1.7 Rates And Charges (Cont'd)

	<u>Monthly Rate</u>	<u>Nonrecurring Charge</u>
B. Channel Mileage (Cont'd)		
2. Facility (Per Mile)		
(a) Digilink® Service		
19.2 Kbps, 56.0 Kbps, 64.0 Kbps		
Month to Month	\$2.55	\$0.00
12 - 23 Months	2.50	0.00
24 - 35 Months	2.45	0.00
36 - 59 Months	2.40	0.00
60 - 84 Months	2.30	0.00

ISSUED:  
December 10, 2003

BY: Richard D. Lawson  
State Executive, External Affairs  
319 Madison  
Jefferson City, MO 65101

EFFECTIVE:  
January 10, 2004

**Cancelled**

October 13, 2006

Missouri Public  
Service Commission

**Filed**

Missouri Public  
Service Commission

Embarq Missouri, Inc.  
d/b/a Embarq

Section 6  
Third Revised Page 34  
Cancels Second Revised Page 34

PRIVATE LINE SERVICE

6.1 Link Services (Cont'd)

6.1.7 Rates And Charges (Cont'd)

	<u>Monthly Rate</u>	<u>Nonrecurring Charge</u>	
B. Channel Mileage (Cont'd)			
2. Facility (Per Mile) (Cont'd)			
(b) Translink Service			
			(D)
			(D)
1.544 Mbps			
Month to Month	<b>\$53.00</b>	\$0.00	( I )
12 - 23 Months	45.60	0.00	
24 - 35 Months	44.64	0.00	
36 - 59 Months	<b>36.00</b>	0.00	( I )
60 - 84 Months	27.00	0.00	

ISSUED:  
January 20, 2009

BY: Darlene N. Terry  
Manager - Tariffs  
5454 W. 110th Street  
Overland Park, Kansas 66211

EFFECTIVE:  
February 1, 2009

CANCELLED  
October 19, 2009  
Missouri Public  
Service Commission  
TN-2010-0086; JI-2010-0157

FILED  
Missouri Public  
Service Commission  
JI-2009-0529

Embarq Missouri, Inc.  
d/b/a Embarq

Section 6  
Second Revised Page 34  
Cancels First Revised Page 34

PRIVATE LINE SERVICE

6.1 Link Services (Cont'd)

6.1.7 Rates And Charges (Cont'd)

	<u>Monthly Rate</u>	<u>Nonrecurring Charge</u>	
B. Channel Mileage (Cont'd)			
2. Facility (Per Mile) (Cont'd)			
(b) Translink Service			
128 Kbps			
Month to Month	<b>\$12.60</b>	\$0.00	(1)
12 - 23 Months	<b>12.60</b>	0.00	
24 - 35 Months	<b>12.60</b>	0.00	
36 - 59 Months	<b>12.60</b>	0.00	
60 - 84 Months	<b>12.60</b>	0.00	(1)
256 Kbps			
Month to Month	23.00	0.00	
12 - 23 Months	23.00	0.00	
24 - 35 Months	23.00	0.00	
36 - 59 Months	23.00	0.00	
60 - 84 Months	23.00	0.00	
384 Kbps			
Month to Month	<b>35.50</b>	0.00	(1)
12 - 23 Months	<b>35.50</b>	0.00	
24 - 35 Months	<b>35.50</b>	0.00	(1)
36 - 59 Months	32.00	0.00	
60 - 84 Months	27.00	0.00	
512 Kbps			
Month to Month	48.00	0.00	
12 - 23 Months	45.60	0.00	
24 - 35 Months	44.64	0.00	
36 - 59 Months	32.00	0.00	
60 - 84 Months	27.00	0.00	
1.544 Mbps			
Month to Month	48.00	0.00	
12 - 23 Months	45.60	0.00	
24 - 35 Months	44.64	0.00	
36 - 59 Months	32.00	0.00	
60 - 84 Months	27.00	0.00	

ISSUED:  
December 3, 2007

BY: Darlene N. Terry  
Manager - Tariffs  
5454 W. 110th Street  
Overland Park, KS 66211

EFFECTIVE:  
January 30, 2008

CANCELLED  
February 1, 2009  
Missouri Public  
Service Commission  
JI-2009-0529

FILED  
Missouri Public  
Service Commission

Embarq Missouri, Inc.  
d/b/a Embarq

Section 6  
First Revised Page 34  
Cancels Original Page 34

PRIVATE LINE SERVICE

6.1 Link Services (Cont'd)

6.1.7 Rates And Charges (Cont'd)

	<u>Monthly Rate</u>	<u>Nonrecurring Charge</u>
B. Channel Mileage (Cont'd)		
2. Facility (Per Mile) (Cont'd)		
(b) <b>Translink</b> Service (T)		
128 Kbps		
Month to Month	\$12.00	\$0.00
12 - 23 Months	12.00	0.00
24 - 35 Months	12.00	0.00
36 - 59 Months	12.00	0.00
60 - 84 Months	12.00	0.00
256 Kbps		
Month to Month	23.00	0.00
12 - 23 Months	23.00	0.00
24 - 35 Months	23.00	0.00
36 - 59 Months	23.00	0.00
60 - 84 Months	23.00	0.00
384 Kbps		
Month to Month	34.00	0.00
12 - 23 Months	34.00	0.00
24 - 35 Months	34.00	0.00
36 - 59 Months	32.00	0.00
60 - 84 Months	27.00	0.00
512 Kbps		
Month to Month	48.00	0.00
12 - 23 Months	45.60	0.00
24 - 35 Months	44.64	0.00
36 - 59 Months	32.00	0.00
60 - 84 Months	27.00	0.00
1.544 Mbps		
Month to Month	48.00	0.00
12 - 23 Months	45.60	0.00
24 - 35 Months	44.64	0.00
36 - 59 Months	32.00	0.00
60 - 84 Months	27.00	0.00

ISSUED:  
September 13, 2006

BY: Darlene N. Terry  
Manager - Tariffs  
5454 W. 110th Street  
Overland Park, KS 66211

EFFECTIVE:  
October 13, 2006

CANCELLED  
January 30, 2008  
Missouri Public  
Service Commission

**Filed**  
Missouri Public  
Service Commission



SPRINT MISSOURI, INC.  
d/b/a SPRINT

Section 6

Original Page 34

PRIVATE LINE SERVICE

6.1 Link Services (Cont'd)

6.1.7 Rates And Charges (Cont'd)

	<u>Monthly Rate</u>	<u>Nonrecurring Charge</u>
B. Channel Mileage (Cont'd)		
2. Facility (Per Mile) (Cont'd)		
(b) Translink® Service		
128 Kbps		
Month to Month	\$12.00	\$0.00
12 - 23 Months	12.00	0.00
24 - 35 Months	12.00	0.00
36 - 59 Months	12.00	0.00
60 - 84 Months	12.00	0.00
256 Kbps		
Month to Month	23.00	0.00
12 - 23 Months	23.00	0.00
24 - 35 Months	23.00	0.00
36 - 59 Months	23.00	0.00
60 - 84 Months	23.00	0.00
384 Kbps		
Month to Month	34.00	0.00
12 - 23 Months	34.00	0.00
24 - 35 Months	34.00	0.00
36 - 59 Months	32.00	0.00
60 - 84 Months	27.00	0.00
512 Kbps		
Month to Month	48.00	0.00
12 - 23 Months	45.60	0.00
24 - 35 Months	44.64	0.00
36 - 59 Months	32.00	0.00
60 - 84 Months	27.00	0.00
1.544 Mbps		
Month to Month	48.00	0.00
12 - 23 Months	45.60	0.00
24 - 35 Months	44.64	0.00
36 - 59 Months	32.00	0.00
60 - 84 Months	27.00	0.00

ISSUED:  
December 10, 2003

BY: Richard D. Lawson  
State Executive, External Affairs  
319 Madison  
Jefferson City, MO 65101

EFFECTIVE:  
January 10, 2004

**Cancelled**

October 13, 2006

Missouri Public  
Service Commission

**Filed**

Missouri Public  
Service Commission

Embarq Missouri, Inc.  
d/b/a Embarq

Section 6  
First Revised Page 35  
Cancels Original Page 35

PRIVATE LINE SERVICE

6.1 Link Services (Cont'd)

6.1.7 Rates And Charges (Cont'd)

B. Channel Mileage (Cont'd)

2. Facility (Per Mile) (Cont'd)

(c) **Lightlink** Service

(T)

44.736 Mbps

Month to Month<sup>1</sup>

12 - 23 Months

24 - 35 Months

36 - 59 Months

60 - 84 Months

Monthly  
Rate

Nonrecurring  
Charge

\$150.00

135.00

120.00

105.00

90.00

N/A

\$0.00

0.00

0.00

0.00

<sup>1</sup>Month-to-month rates are available only after the expiration of one of the Term Discount Plans.

ISSUED:  
September 13, 2006

BY: Darlene N. Terry  
Manager - Tariffs  
5454 W. 110th Street  
Overland Park, KS 66211

EFFECTIVE:  
October 13, 2006

CANCELLED  
October 19, 2009  
Missouri Public  
Service Commission  
TN-2010-0086; JI-2010-0157

**Filed**  
Missouri Public  
Service Commission

SPRINT MISSOURI, INC.  
d/b/a SPRINT

Section 6

Original Page 35

PRIVATE LINE SERVICE

6.1 Link Services (Cont'd)

6.1.7 Rates And Charges (Cont'd)

	<u>Monthly Rate</u>	<u>Nonrecurring Charge</u>
--	-------------------------	--------------------------------

B. Channel Mileage (Cont'd)

2. Facility (Per Mile) (Cont'd)

(c) Lightlink<sup>SM</sup> Service

44.736 Mbps

Month to Month<sup>1</sup>

12 - 23 Months

24 - 35 Months

36 - 59 Months

60 - 84 Months

\$150.00

135.00

120.00

105.00

90.00

N/A

\$0.00

0.00

0.00

0.00

<sup>1</sup>Month-to-month rates are available only after the expiration of one of the Term Discount Plans.

ISSUED:  
December 10, 2003

BY: Richard D. Lawson  
State Executive, External Affairs  
319 Madison  
Jefferson City, MO 65101

EFFECTIVE:  
January 10, 2004

**Cancelled**

October 13, 2006

Missouri Public  
Service Commission

**Filed**

Missouri Public  
Service Commission

PRIVATE LINE SERVICE

6.1 Link Services (Cont'd)

6.1.7 Rates And Charges (Cont'd)

	<u>Monthly Rate</u>	<u>Nonrecurring Charge</u>	
C. Optional Features and Functions			
1. <b>Translink</b> Service			(T)
(a) Central Office Multiplexing DS1 to DS0 - Per Arrangement			
Month to Month	\$375.00	\$125.00	
12 – 23 Months	325.00	125.00	
24 – 35 Months	300.00	125.00	
36 – 59 Months	275.00	125.00	
60 – 84 Months	250.00	125.00	
(b) Clear Channel Capability (CCC) - Per Channel Termination	\$0.00	\$386.50	
(c) Extended Superframe Format (ESF) - Per Channel Termination	N/A	N/A	
(d) Multiplexed Service Connection - Per DS0	\$8.00	\$100.00	
2. <b>Lightlink</b> Service			(T)
(a) Central Office Multiplexing DS3 to DS1 - Per Arrangement			
Month to Month <sup>1</sup>	\$475.00	N/A	
12 – 23 Months	475.00	\$150.00	
24 – 35 Months	475.00	150.00	
36 – 59 Months	475.00	150.00	
60 – 84 Months	475.00	150.00	
(b) Clear Channel Capability (CCC) <sup>2</sup> - Per Channel Termination	\$0.00	\$275.00	
(c) Multiplexed Service Connection - Per DS1	\$8.00	\$55.00	

<sup>1</sup>Month-to-month rates are available only after the expiration of one of the Term Discount Plans.

<sup>2</sup>A nonrecurring charge will apply when Clear Channel Capability is ordered for a DS1 circuit already in service and will not apply when provided as part of the initial installation.

ISSUED:  
September 13, 2006

BY: Darlene N. Terry  
Manager - Tariffs  
5454 W. 110th Street  
Overland Park, KS 66211

EFFECTIVE:  
October 13, 2006

PRIVATE LINE SERVICE

6.1 Link Services (Cont'd)

6.1.7 Rates And Charges (Cont'd)

	<u>Monthly Rate</u>	<u>Nonrecurring Charge</u>
C. Optional Features and Functions		
1. Translink® Service		
(a) Central Office Multiplexing DS1 to DS0 - Per Arrangement		
Month to Month	\$375.00	\$125.00
12 – 23 Months	325.00	125.00
24 – 35 Months	300.00	125.00
36 – 59 Months	275.00	125.00
60 – 84 Months	250.00	125.00
(b) Clear Channel Capability (CCC) - Per Channel Termination	\$0.00	\$386.50
(c) Extended Superframe Format (ESF) - Per Channel Termination	N/A	N/A
(d) Multiplexed Service Connection - Per DS0	\$8.00	\$100.00
2. Lightlink <sup>SM</sup> Service		
(a) Central Office Multiplexing DS3 to DS1 - Per Arrangement		
Month to Month <sup>1</sup>	\$475.00	N/A
12 – 23 Months	475.00	\$150.00
24 – 35 Months	475.00	150.00
36 – 59 Months	475.00	150.00
60 – 84 Months	475.00	150.00
(b) Clear Channel Capability (CCC) <sup>2</sup> - Per Channel Termination	\$0.00	\$275.00
(c) Multiplexed Service Connection - Per DS1	\$8.00	\$55.00

<sup>1</sup>Month-to-month rates are available only after the expiration of one of the Term Discount Plans.

<sup>2</sup>A nonrecurring charge will apply when Clear Channel Capability is ordered for a DS1 circuit already in service and will not apply when provided as part of the initial installation.

ISSUED:  
December 10, 2003

BY: Richard D. Lawson  
State Executive, External Affairs  
319 Madison  
Jefferson City, MO 65101

EFFECTIVE:  
January 10, 2004

**Cancelled**

October 13, 2006

Missouri Public  
Service Commission

**Filed**

Missouri Public  
Service Commission

Embarq Missouri, Inc.  
d/b/a Embarq

Section 6  
Second Revised Page 37  
Cancels First Revised Page 37

PRIVATE LINE SERVICE

6.1 Link Services (Cont'd)

6.1.7 Rates And Charges (Cont'd)

	<u>Monthly Rate</u>	<u>Nonrecurring Charge</u>	
D. Data Amplification <sup>(1)</sup> - Per Repeater	\$99.00	\$116.50	(T)
E. Central Office Bridging Capability <sup>(1)</sup> - Per Port			(T)
<b>56.0 Kbps</b> , 64.0 Kbps			(D)
Month to Month	\$29.00	\$ 97.50	
12 - 23 Months	22.00	97.50	
24 - 35 Months	20.00	97.50	
36 - 59 Months	18.00	97.50	
60 - 84 Months	16.00	97.50	

<sup>(1)</sup> Circuit Repeater and Central Office Bridging Capability only apply to Digilink Service. (T)

ISSUED:  
January 20, 2009

BY: Darlene N. Terry  
Manager - Tariffs  
5454 W. 110th Street  
Overland Park, Kansas 66211

EFFECTIVE:  
February 1, 2009

Embarq Missouri, Inc.  
d/b/a Embarq

Section 6  
First Revised Page 37  
Cancels Original Page 37

PRIVATE LINE SERVICE

6.1 Link Services (Cont'd)

6.1.7 Rates And Charges (Cont'd)

	<u>Monthly Rate</u>	<u>Nonrecurring Charge</u>
D. Data Amplification <sup>2</sup> - Per Repeater	\$99.00	\$116.50
E. Central Office Bridging Capability <sup>2</sup> - Per Port		
19.2 Kbps, 56.0 Kbps, 64.0 Kbps		
Month to Month	\$29.00	\$ 97.50
12 - 23 Months	22.00	97.50
24 - 35 Months	20.00	97.50
36 - 59 Months	18.00	97.50
60 - 84 Months	16.00	97.50

<sup>2</sup>Circuit Repeater and Central Office Bridging Capability only apply to **Digilink** Service

(T)

ISSUED:  
September 13, 2006

BY: Darlene N. Terry  
Manager - Tariffs  
5454 W. 110th Street  
Overland Park, KS 66211

EFFECTIVE:  
October 13, 2006

CANCELLED  
February 1, 2009  
Missouri Public  
Service Commission  
JI-2009-0529

**Filed**  
Missouri Public  
Service Commission

SPRINT MISSOURI, INC.  
d/b/a SPRINT

PRIVATE LINE SERVICE

6.1 Link Services (Cont'd)

6.1.7 Rates And Charges (Cont'd)

	<u>Monthly Rate</u>	<u>Nonrecurring Charge</u>
D. Data Amplification <sup>2</sup> - Per Repeater	\$99.00	\$116.50
E. Central Office Bridging Capability <sup>2</sup> - Per Port		
19.2 Kbps, 56.0 Kbps, 64.0 Kbps		
Month to Month	\$29.00	\$ 97.50
12 - 23 Months	22.00	97.50
24 - 35 Months	20.00	97.50
36 - 59 Months	18.00	97.50
60 - 84 Months	16.00	97.50

<sup>2</sup>Circuit Repeater and Central Office Bridging Capability only apply to Digilink® Service

ISSUED:  
December 10, 2003

BY: Richard D. Lawson  
State Executive, External Affairs  
319 Madison  
Jefferson City, MO 65101

EFFECTIVE:  
January 10, 2004

**Cancelled**

October 13, 2006

Missouri Public  
Service Commission

**Filed**

Missouri Public  
Service Commission



PRIVATE LINE SERVICE

6.1 Link Services (Cont'd)

6.1.7 Rates And Charges (Cont'd)

F. Nonrecurring Charge

The Installation Nonrecurring Charge is applicable for the initial installation of a Channel Termination to a given Serving Wire Center. The Rearrangement Nonrecurring Charge is applicable for any rearrangement of an existing Channel Termination.

G. Move Charges

A Move Charge applies for Channel Terminations moved to a new location, even when moved on the same premises. The Move Charge is equal to the Channel Termination Installation Nonrecurring Charge and applies in addition to the Service Order Charge-Complex Business located in Section 30 of the P.S.C. MO. No. 22 General Exchange Tariff.

H. Service Connection Charges

A Service Order Charge-Complex Business as set forth in Section 30 of the P.S.C. MO. No. 22 General Exchange Tariff is applicable per customer request. Nonrecurring Charges specified in this tariff section are in lieu of all other Service Connection Charges.

ISSUED:  
December 10, 2003

BY: Richard D. Lawson  
State Executive, External Affairs  
319 Madison  
Jefferson City, MO 65101

EFFECTIVE:  
January 10, 2004

PRIVATE LINE SERVICE

STATEMENT OF SERVICE CLASSIFICATIONS

Presented in this section are the Service Classifications for Embarq Missouri, Inc. pursuant to MoPSC Order of December 4, 2003 in Case No. IO-2003-0281.

SERVICE CATEGORIES	TARIFF REFERENCE	(T)
<u>Competitive</u> <sup>(1)</sup>		
IntraLATA Interexchange Type 102	2.2.1.D.	
Sub-Voice Grade Service-Series 200	2.2.2.D.	
Voice Grade Service-Series 300 and 400	2.2.3.E.	
Private Line Service	2.2.4.	
Signaling	2.2.6.B.	
Channel Conditioning Charges	2.2.7.	
Foreign Exchange Service	3.1.4.C.	
Link Services	6.1.7.	

(1) Service may be provided/priced on an exchange-specific basis in both competitive and non-competitive exchanges.

ISSUED:  
August 2, 2007

BY: Darlene N. Terry  
Manager - Tariffs  
5454 W. 110th Street  
Overland Park, KS 66211

EFFECTIVE:  
September 1, 2007

Embarq Missouri, Inc.  
d/b/a Embarq

Section 7  
First Revised Page 1  
Cancels Original Page 1

## PRIVATE LINE SERVICE

## STATEMENT OF SERVICE CLASSIFICATIONS

Presented in this section are the Service Classifications for **Embarq** Missouri, Inc. pursuant to MoPSC (T)  
Order of December 4, 2003 in Case No. IO-2003-0281.

<b>Service</b>	<b>Competitive/Service Classification</b>	<b>Tariff Reference</b>
<b>IntraLATA Interexchange Type 102</b>	Statewide Competitive/Non-Basic	2.2.1.D.
<b>Sub-Voice Grade Service-Series 200</b>	Statewide Competitive/Non-Basic	2.2.2.D.
<b>Voice Grade Service-Series 300 and 400</b>	Statewide Competitive/Non-Basic	2.2.3.E.
<b>Private Line Service</b>	Statewide Competitive/Non-Basic	2.2.4.
<b>Signaling</b>	Statewide Competitive/Non-Basic	2.2.6.B.
<b>Channel Conditioning Charges</b>	Statewide Competitive/Non-Basic	2.2.7.
<b>Foreign Exchange Service</b>	Statewide Competitive/Non-Basic	3.1.4.C.
<b>Link Services</b>	Statewide Competitive/Non-Basic	6.1.7.

ISSUED:  
September 13, 2006

BY: Darlene N. Terry  
Manager - Tariffs  
5454 W. 110th Street  
Overland Park, KS 66211

EFFECTIVE:  
October 13, 2006

CANCELLED  
September 1, 2007  
Missouri Public  
Service Commission

**Filed**  
Missouri Public  
Service Commission

SPRINT MISSOURI, INC.  
d/b/a SPRINT

Section 7

Original Page 1

## PRIVATE LINE SERVICE

## STATEMENT OF SERVICE CLASSIFICATIONS

Presented in this section are the Service Classifications for Sprint Missouri, Inc. pursuant to MoPSC Order of December 4, 2003 in Case No. IO-2003-0281.

<b>Service</b>	<b>Competitive/Service Classification</b>	<b>Tariff Reference</b>
<b>IntraLATA Interexchange Type 102</b>	Statewide Competitive/Non-Basic	2.2.1.D.
<b>Sub-Voice Grade Service-Series 200</b>	Statewide Competitive/Non-Basic	2.2.2.D.
<b>Voice Grade Service-Series 300 and 400</b>	Statewide Competitive/Non-Basic	2.2.3.E.
<b>Private Line Service</b>	Statewide Competitive/Non-Basic	2.2.4.
<b>Signaling</b>	Statewide Competitive/Non-Basic	2.2.6.B.
<b>Channel Conditioning Charges</b>	Statewide Competitive/Non-Basic	2.2.7.
<b>Foreign Exchange Service</b>	Statewide Competitive/Non-Basic	3.1.4.C.
<b>Link Services</b>	Statewide Competitive/Non-Basic	6.1.7.

ISSUED:  
April 1, 2004

BY: Richard D. Lawson  
State Executive, External Affairs  
319 Madison  
Jefferson City, MO 65101

EFFECTIVE:  
May 1, 2004

**Cancelled**

October 13, 2006

Missouri Public  
Service Commission

**Filed**

Missouri Public  
Service Commission