

**BEFORE THE PUBLIC SERVICE COMMISSION  
OF THE STATE OF MISSOURI**

In the Matter of Union Electric Company )  
d/b/a Ameren Missouri's Filing to Implement )  
Regulatory Changes in Furtherance of ) Case No. EO-2012-0142  
Energy Efficiency as allowed by MEEIA. )

**AGREEMENT TO INCLUDE ADDITIONAL MEASURES  
IN AMEREN MISSOURI'S TECHNICAL RESOURCE MANUAL**

COME NOW Union Electric Company d/b/a Ameren Missouri ("Ameren Missouri"), the Staff of the Missouri Public Service Commission ("Staff"), the Office of the Public Counsel, the Missouri Department of Natural Resources, the Natural Resources Defense Council, Sierra Club, and Earth Island Institute d/b/a Renew Missouri, (together, the "Signatories") and present this *Agreement to Include Additional Measures in Ameren Missouri's Technical Resource Manual* ("Agreement") to the Missouri Public Service Commission ("Commission") for approval, and in support thereof respectfully state as follows:

1. On July 5, 2012, the Signatories and other parties submitted a *Unanimous Stipulation and Agreement Resolving Ameren Missouri's MEEIA Filing* (Stipulation), which resolved all issues in the case. The Commission issued an order approving the Stipulation on August 1, 2012.

2. The Stipulation provided for approval of the Company's proposed Technical Resource Manual (TRM), which occurred upon the Commission's approval of the Stipulation on August 1, 2012. The TRM sets forth measures, the level of energy savings, incremental costs and effective, useful lives associated with each measure.

3. Since the approval of the Stipulation, Ameren Missouri has hired the contractors that will be implementing the residential and commercial energy efficiency programs. Those contractors have recommended that additional measures be added to the TRM. Additionally, the

contractors have recommended lowering the minimum incentive levels for certain measures.

4. This Agreement contains five attachments:

A. Attachment A contains a brief explanation of each additional measure and where information on that measure can be found in the revised TRM.

B. Attachment B is the revised TRM.

C. Attachment C is a red-lined version of the revised TRM, so that all changes from the Commission-approved TRM can be identified.

D. Attachment D is the revised list of residential incentive ranges. New measure incentive ranges are highlighted in yellow. Changes to the previously approved ranges are highlighted in blue.

E. Attachment E is the revised list of business incentive ranges. New measure incentive ranges are highlighted in yellow.

5. The Signatories to this Agreement ask the Commission to approve the revised TRM (Attachment B), the new incentive ranges (Attachments D and E) and to order that these documents replace the TRM and incentive ranges which were approved earlier in this case. The Signatories agree that this means the revised TRM will be used to calculate Ameren Missouri's TD-NSB share.

6. The Signatories agree that, along with filing this Agreement, Ameren Missouri shall file a motion for expedited treatment so that the Commission has time to issue an order that is effective no later than February 13, 2013. This will enable the Company to offer these additional measures as soon as possible.

7. The following parties are not Signatories to this Agreement but have indicated that they do not oppose it: the Missouri Industrial Energy Consumers and Barnes-Jewish Hospital.

Respectfully submitted,

/s/ Wendy K. Tatro

**Wendy K. Tatro**, #60261

Corporate Counsel

**Thomas M. Byrne**, #33340

Director & Assistant General Counsel

Ameren Services Company

P.O. Box 66149, MC 1310

St. Louis, MO 63166-6149

(314) 554-3484 (phone)

(314) 554-2514

(314) 554-4014 (fax)

[AmerenMOService@ameren.com](mailto:AmerenMOService@ameren.com)

James B. Lowery, #40503

Smith Lewis, LLP

111 S. Ninth Street, Suite 200

P.O. Box 918

Columbia, MO 65205

Telephone: (573) 443-3141

Fax: (573) 442-6686

Email: [lowery@smithlewis.com](mailto:lowery@smithlewis.com)

**Attorneys for Union Electric Company  
d/b/a Ameren Missouri**

**/s/ Nathan Williams**

Nathan Williams  
Deputy Counsel  
Missouri Bar No. 35512  
Attorney for the Staff of the  
Missouri Public Service Commission  
P.O. Box 360  
Jefferson City, MO 65102  
(573) 751-8706 (Telephone)  
(573) 751-9285 (Fax)  
[nathan.williams@psc.mo.gov](mailto:nathan.williams@psc.mo.gov)

**/s/ Lewis R. Mills, Jr.**

Lewis R. Mills, Jr. (#35275)  
Public Counsel  
Office of the Public Counsel  
P.O. Box 2230  
Jefferson City, MO 65102  
(573) 751-1304 (Telephone)  
(573) 751-5562 (Fax)  
[lewis.mills@ded.mo.gov](mailto:lewis.mills@ded.mo.gov)

**/s/ Jennifer S. Frazier**

Jennifer S. Frazier  
Missouri Bar No. 39127  
Deputy Chief Counsel  
Office of Attorney General  
Agriculture & Environmental Division  
P.O. Box 899  
Jefferson City, MO 65102  
(573) 751-8795 (Telephone)  
(573) 751-8796 (Fax)  
[jenny.frazier@ago.mo.gov](mailto:jenny.frazier@ago.mo.gov)

Attorney for Missouri Department  
of Natural Resources

**/s/ Henry Robertson**

Henry Robertson, #29502  
Great Rivers Environmental Law Center  
705 Olive Street, Suite 614  
St. Louis, MO 63101  
(314) 231-4181 (Telephone)  
[hrobertson@greatriverslaw.org](mailto:hrobertson@greatriverslaw.org)

Attorney for Natural Resources Defense Council

**/s/ Henry Robertson**

Henry Robertson, #29502  
Great Rivers Environmental Law Center  
705 Olive Street, Suite 614  
St. Louis, MO 63101  
(314) 231-4181 (Telephone)  
[hrobertson@greatriverslaw.org](mailto:hrobertson@greatriverslaw.org)

Attorney for the Sierra Club

**/s/ Henry Robertson**

Henry Robertson, #29502  
Great Rivers Environmental Law Center  
705 Olive Street, Suite 614  
St. Louis, MO 63101  
(314) 231-4181 (Telephone)  
[hrobertson@greatriverslaw.org](mailto:hrobertson@greatriverslaw.org)

Attorney for Earth Island Institute d/b/a  
Renew Missouri

**CERTIFICATE OF SERVICE**

I do hereby certify that a true and correct copy of the foregoing document has been hand-delivered, transmitted by e-mail, or mailed, First Class, postage prepaid, this 8<sup>th</sup> day of February, 2013, to counsel for all parties on the Commission's service list in this case.

*/s/ Wendy K. Tatro*

## TRM Change Summary

### Measure Changes

Customer Class	Measure	Change	Source	Page # in TRM
Residential	Energy Room Air Purifier	New Measure Added	Ameren Missouri PY 3 EMV	31
Residential	Refrigerator Coil Cleaning Brush	New Measure Added	Honeywell Low Income Bid	32
Residential	Energy Star Water Cooler	New Measure Added	Ameren Missouri PY 3 EMV	33
Residential	Ceiling Insulation	New Measure Added	Ameren Illinois TRM 2012 2009 Ameren Missouri DSM Potential Study NOAA weather data (St. Louis)	38
Business	Walk-In Evaporator Fan Controls	Measure will be offered in the Custom program and will not be a prescriptive measure identified in the TRM due to ambiguity around incremental cost and savings.		
Business	Night Covers	New Measure Added	Lockheed Martin proposal October 2012	67
Business	ECM for Refrigeration	New Measure Added	Lockheed Martin proposal October 2012	68
Business	Auto door closers	New Measure Added	Lockheed Martin proposal October 2012	69
Business	Desktop Virtualization - Thin Client 2	New Measure Added	Lockheed Martin proposal October 2012	85
Business	Energy Star Personal Computer	New Measure Added	Lockheed Martin proposal October 2012	86
Business	PC Power Management	New Measure Added	Lockheed Martin proposal October 2012	87
Business	Chilled Water Reset Controls	kW typo was 0.000369 kW/ton, should be 0.0064 kW/ton	Ameren - Morgan Measure Database	87

## Edits/Grammatical Fixes

Summary of Grammatical Change	Page Number	Rationale
Added in EUL to Abbreviations	ii	EUL is used throughout the document
Refrigerator and Freezer Recycling age restriction was removed.	30	Due to new retail channel, it is possible the program will pick up units newer than 2002. The retail contractors will be trained to only pick up eligible 2002 and older units. The goal in removing this restriction was not to change equipment eligibility requirements of 2002 and older, but rather to be transparent in the event that some may come in and customers may receive a rebate. This number of units is expected to be under 6% based off conversations with ARCA and review of other utility programs.
Re-labeled Beverage Vending Machine Controls	65	Further identifies measure as the controls, not the vending machine itself.
Edited the word "Baseline" as it was misspelled	67	Improves clarity of document.
Re-labeled Commercial Motors and Drives to Pumps and Drives	71	Motors are not included in programs, all subsequent measures refer to pumps, reduces confusion
Included clarifying language for windows	87	Clarifies savings are on a per building basis, not a per window basis.
Re-labeled Energy Savings credit and demand savings credit	88, 89	Was mis-labeled previously, inappropriate for specific measures
Removed non-eligibility language for Custom air compressor measures	97, 99	Air compressor measures ARE eligible to receive incentives in program



# Appendix A – Technical Resource Manual

Table of Abbreviations .....	ii
Introduction .....	1
Special issues .....	2
Protocol for Deeming Measures Not Found Within TRM .....	4
Residential Energy Efficiency Measures.....	5
Residential Lighting.....	5
Residential HVAC Applications .....	7
Residential Appliances.....	30
Residential Building Shell.....	37
Residential Water Heating .....	40
Commercial and Industrial Energy Efficiency Measures.....	46
Commercial Lighting .....	46
Commercial Cooking Equipment.....	58
Commercial Refrigeration .....	62
Commercial Hot Water Measures .....	69
Commercial Pumps and Drives.....	71
Commercial HVAC Applications.....	75
Commercial Miscellaneous .....	85
Commercial Optimization Measures .....	87
Custom Project Analysis Methodology .....	90
Building Simulation Protocols .....	104

### Table of Abbreviations

<u>Term</u>	<u>Abbrev</u>	<u>Term</u>	<u>Abbrev</u>
Air Source Heat Pump	ASHP	American Society of Heating, Refrigerating & Air-Conditioning Engineers	ASHRAE
Annual Fuel Utilization Efficiency	AFUE	Building Automation System	BAS
Central Air Conditioner	CAC	Compact Fluorescent Light	CFL
Database for Energy Efficiency Resources	DEER	Demand controlled ventilation	DCV
Department of Energy	DOE	Dual Fuel Heat Pump	DFHP
Effective Useful Life	EUL	Energy Efficiency Ratio	EER
Electronically Commutated Motors	ECM	Energy Management System	EMS
Energy Independence & Security Act	EISA	Equivalent Full Load Hours	EFLH
Environmental Protection Agency	EPA	Federal Energy Management Program	FEMP
Evaluation Measurement & Verification	EMV	Integrated Part Load Value	IPLV
High Intensity Discharge	HID	International Energy Conservation Code	IECC
Integrated Resource Plan	IRP	Kilowatt per Hour	kWh
Kilowatt	kW	National Appliance Energy Conservation Act	NAECA
Missouri Energy Efficiency Investment Act	MEEIA	Net Present Value	NPV
National Electrical Manufacturers Association	NEMA	Packaged Terminal Heat Pump	PTHP
Packaged Terminal Air Conditioner	PTAC	Remaining Efficient Life	REL
Real Discount Rate	RDR	Seasonal Energy Efficiency Ratio	SEER
Remaining Useful Life	RUL	Technical Analysis Study	TAS
Solar Heat Gain Coefficient	SHGC	Thermostatic Expansion Valves	TXV
Technical Resource Manual	TRM	Utility Discount Rate	UDR
Typical Meteorological Year	TMY	Variable Air Volume	VAV
Unit Energy Consumption	UEC	Variable Speed Drive	VSD
Variable Frequency Drive	VFD		

## Introduction

The Ameren Missouri Technical Resource Manual (TRM) was developed to establish deemed measure level values and/or protocols for measures that cannot be deemed. These values and protocols will be used prospectively for the three year implementation cycle as defined in the Missouri Energy Efficiency Investment Act (MEEIA) rules.

The technologies are divided into 2 main sections, each contains multiple end-use categories.

- Residential Applications
  - Residential Lighting
  - Residential HVAC
  - Residential Appliances
  - Residential Building Shell
  - Residential Water Heating
  
- Commercial and Industrial Applications
  - Commercial Lighting
  - Cooking Equipment
  - Commercial Refrigeration
  - Commercial Hot Water Measures
  - Commercial Motors and Drives
  - Commercial HVAC Applications
  - Commercial Miscellaneous
  - Commercial Optimization Measures
  - Custom Project Analysis Methodology

A separate table is provided for each technology containing equations that can be used to calculate gross annual electric energy and demand savings. Furthermore, each table identifies baseline efficiency levels, which are used as the standard for which the energy efficient technology is measured against. The tables also highlight the minimum efficiency criteria required for the measure to receive a savings credit. Each measure is allocated a specific effective useful life (EUL), which is the amount of time that particular measure is expected to perform. Finally, each measure is also given an incremental cost, which indicates the cost differential between the baseline efficiency and the minimum required efficiency highlighted in each individual table. Key assumptions utilized for each measure are highlighted in a bulleted list below each table.

To arrive at the individual measure level assumptions, Ameren Missouri consulted multiple databases, Evaluation Measurement & Verification (EMV) Reports, and other TRMs. Missouri specific data, where available, took precedence over all other data available. Measure level values were given primary precedence if they came from

Ameren Missouri EMV reports. For measures not contained in the EMV reports, Ameren Missouri consulted its internal database developed by Morgan Marketing Partners which utilizes Missouri specific weather, building vintages, and home sizes. Finally, other state and utility TRMs were consulted including the 2005 Pennsylvania draft TRM and the 2009 Ohio TRM. These other TRMs were mainly used to derive engineering equations for estimating energy savings and other formatting ideas and practices, no measure level savings, costs, or effective useful lives were utilized from these TRMs.

The TRM values will be updated once every three years via the EM&V review process. Any new measure level data changes will be applied prospectively for the next three year implementation cycle. If there are measures not included within this TRM, or if new measures proliferate within Ameren Missouri's service territory, a process will be followed to include these new technologies as defined, starting on page 4.

### Special issues

In developing this TRM, several key issues arose that necessitate further discussion. The first topic involves weather sensitive measures. Typical weather sensitive measures include:

- HVAC measures (heat pumps, air conditioners, furnaces, chillers, etc.);
- Building shell (insulation, air sealing, duct sealing, windows, etc.);
- Thermostats;
- Energy Management Systems;
- Condensers;
- Other measures whose savings depend on weather.

For all weather sensitive measures not included in program year 2 (October 2009 – September 2010) EMV reports, building simulation modeling was conducted by Morgan Marketing Partners. The process is outlined, starting on page 99. The weather sensitive measure values reflected in this TRM as indicated by the footnote, “[#] Taken from Morgan Measure Libraries”, were derived using a building simulation approach. The equations listed provide a different method to estimate measure level savings in the case the user does not have access to the appropriate simulation modeling tools (DOE 2-2 or E-quest). The building simulation approach, however, is far more accurate and Ameren Missouri believes this is the best method to quantify measure level energy and demand savings.

Another issue that arose involves the demand savings estimates. The values represented within this TRM were either provided by EMV contractors or supplied by Morgan Marketing Partners. While these values are meant to represent the coincident peak demand savings, they may not be equivalent to the coincident savings that are

used when developing the Integrated Resource Plan (IRP). This is due to the operating characteristics of the energy efficiency modeling tool used by Ameren Missouri that models savings against class load shapes, which typically do not have peaks coincident with the Ameren Missouri system peak. The coincident peak impact used for developing the IRP is derived from “calibrated” end-use and system load shapes that were developed as part of the load forecasting process. A description of the forecast development process can be found in Chapter 3 of the Ameren Missouri 2011 IRP and specifics regarding the calibration of end-use load shapes are located in Section 3.2.2 of the Ameren Missouri 2011 IRP<sup>1</sup>. The appropriate “calibrated” end-use load shapes are applied to each energy efficiency measure energy savings and scaled based on the level of energy savings for that measure. The resulting hourly value that is coincident with the system peak is the coincident demand used for IRP development purposes. Ameren Missouri uses the loadshape methodology in the IRP process to maintain consistency with its load forecasting approach.

Early replacement measures are included in this TRM as well. This type of measure (mainly applicable to HVAC measures, specifically heat pumps and air conditioners) is exactly as the name suggests, replacing existing installed equipment with a new efficient alternative. Several key factors are involved when conducting early replacement cost effectiveness analysis.

1. Remaining effective useful life of the existing equipment (assumed to be 1/3 of the life of the equipment). For example, an air conditioner lasts 18 years, regardless of efficiency. The existing equipment installed in the home would then have 6 years of remaining useful life.
2. Remaining effective useful life of the efficient equipment (assumed to be 2/3 of the life of the equipment). For example, an air conditioner lasts 18 years, regardless of efficiency. The existing equipment installed in the home would then have 12 years of remaining useful life.
3. There are two levels of savings. One level of savings occurs from the new, efficient equipment and the existing, installed unit for the remaining effective useful life of the existing unit. The next level of savings is obtained by subtracting the current federal standard or code equipment’s consumption from the new efficient equipment. Example: replacing an existing Seasonal Energy Efficiency Ratio (SEER) 8 central air conditioner with a new SEER 15 air conditioner. There would be 6 years of savings for the first Tier (SEER 8 kWh – SEER 15 kWh), and then there would be 12 years of savings from the second tier (SEER 13 (code) kWh – SEER 15 kWh).

---

<sup>1</sup> Ameren Missouri’s 2011 IRP can be found here:  
<http://www.ameren.com/sites/aeu/Environment/Renewables/Pages/IntegratedResourcePlan.aspx>

4. Incremental cost calculation. This is typically calculated as the difference between the full cost of the efficient measure and the Net Present Value of the Standard/Code baseline equipment. The Standard/Code measure will be installed at the expiration of the remaining useful life of the existing equipment (in the previous example, 6 years from today).

Evaluating the incremental costs associated with lighting measures in cases where the efficient technology has a longer life than the baseline measure being replaced also deserves a brief discussion. An example of this is a Compact Fluorescent Light (CFL) bulb. A CFL lasts 9 years, while a conventional incandescent light bulb only lasts 2 years. This differential in lifetimes indicates that the incandescent bulb would actually need to be replaced 4 times over the life of the CFL. Furthermore, Energy Independence & Security Act (EISA) has implications on the baseline technology, eliminating conventional incandescent bulbs and instilling new, more efficient bulbs. As mentioned in the section entitled, “Legislative Impacts” new halogen bulbs will likely be the baseline, and each bulb was assumed to cost \$2 (based off of primary market data collected by Ameren Missouri’s contractors). By comparing the net present value of the CFL bulb installed today (\$3.00), with the Net Present Value (NPV) of the lifetime of incandescent replacements (\$6.57), the incremental cost is actually negative as the efficient measure is cheaper than the baseline unit. Table 1 demonstrates the lifetime financial savings continually replacing incandescent light bulbs over the life of the CFL exceed the present value of the cost of the CFL.

**Table 1 Incremental Cost for Lighting Measures**

	NPV	2012	2013	2014	2015	2016	2017	2018	2019	2020
Efficient (CFL)	\$3.00	\$ 3.0								
Base (Incandescent EISA compliant)	\$6.57	\$ 0.5	\$ 0.5	\$ 2.0	\$ 0.0	\$ 2.0	\$ 0.0	\$ 2.0	\$ 0.0	\$ 2.0

The following sections identify various energy efficiency measures for both the residential and commercial and industrial end-users. The values expressed represent Ameren Missouri’s best effort to utilize Missouri specific data and where this type of data was not readily available, national best practices.

### Protocol for Deeming Measures Not Found Within TRM

If a measure or technology is discovered to yield energy and demand savings and is not found within this TRM, the following process will be followed to deem measure level energy and demand savings, incremental costs, and effective useful life. While it may be possible there are energy efficiency measures not contained within this TRM, it is unlikely those measures will have significant contributions to the portfolio savings.

1. The following information will be distributed to the appropriate stakeholders for a 2 week review and commenting period.
  - Measure level description (i.e. what the technology does, the efficiency level of the new measure and the baseline efficiency level of the existing technology);
  - Measure level energy and demand savings (and any equations that may be used to calculate those savings);
  - Measure level incremental costs;
  - Effective useful life;
  - All applicable studies, databases, reports, papers, or other supporting documentation and workpapers that inform each assumption for the proposed measure(s).
2. The appropriate EMV consultant will be asked to review inputs and calculation methodologies to assess reasonableness.
3. At the end of the two week period, a conference call will be held to solidify each measure level assumption (majority vote wins).

The TRM will be updated with the new measure value and the new measure will be used prospectively.

## **Residential Energy Efficiency Measures**

### **Residential Lighting**

The energy and demand savings for each residential lighting measure can be calculated using the following formulae:

It should also be noted that efficient lighting also impacts heating loads. The following equation can be used to estimate interactive effects for increased heating.



## Appendix A – Technical Resource Manual

## Ameren Missouri

LED Dimmable Light Bulb	12	25	Incandescent Dimmable Bulb	60.7	2.7 <sup>9</sup>	48	0	\$32.97
LED Flood PAR30 Bulb POST-EISA	15	25	Incandescent Flood Light Bulb	50.5	2.7 <sup>9</sup>	35	0	\$5.97
LED Flood PAR38 Bulb POST-EISA	18	25	Incandescent Flood Light Bulb	50.5	2.7 <sup>9</sup>	32	0	\$7.97
LED Globe G25 Bulb	8	25	Incandescent Globe Light Bulb	40.5	2.7 <sup>9</sup>	32	0	\$22.97
Metal Halide Outdoor Lighting	35	15	Incandescent Outdoor Lighting	100	8 <sup>3</sup>	189.8 <sup>3</sup>	0	\$112.00
Occupancy Sensor	N/A	10	No Sensor	N/A	N/A	217 <sup>3</sup>	0.04 <sup>7</sup>	\$61.00
CFL PRE-EISA for Multifamily	13.5 <sup>1</sup>	9 <sup>1</sup>	Incandescent Bulb	59.1	2.91 <sup>1</sup>	48.4 <sup>1</sup>	0.0075 <sup>11</sup>	\$0.00
CFL POST-EISA for Multifamily	13	9	EISA Compliant Bulb	45	2.7 <sup>11</sup>	31.5	0.00256	\$0.00
Airtight Can Bulb for Multifamily <sup>3,12</sup>	N/A	15	Standard Can Light Bulb	N/A	N/A	85	0.03	\$150.00

[1] Based on PY 2 EMV results

[2] Actual coincident demand impacts are derived using end-use load shapes that are also used for forecasting purposes

[3] Taken from Morgan Measure Libraries

[4] Incremental Cost is Negative when the Present Value of the Base and Efficient are compared

[5] Assumptions from OSRAM SYLVANIA website on HID lighting

[6] Morgan was edited to include HID data from GEP. This demand came from the loadshape since it was not accounted for in Morgan.

[7] Morgan was edited to include Sensor data from Cadmus. This demand came from the loadshape since Morgan did not account for it.

[8] Assumed same hours of use as listed in Morgan for Metal Halide Outdoor

[9] Assumed same hours of use as listed in Morgan for CFLs

[10] Based on numbers from Applied Proactive Technologies

[11] Assumed same parameter as comparable 13W CFLs for single families

[12] Assumed 6 can lights per measure

### Residential HVAC Applications

To most accurately calculate HVAC savings, building simulation modeling should be conducted (see section Building Simulation Protocols). However, if the resources to conduct building simulation do not exist, the following values can be used.

HVAC applications can either be applied as an “early replacement” or as a “replace on fail”. A “replace on fail” analysis is relatively simple, when contrasted with an “early replacement” analysis, as the analysis is a calculation of the energy and demand savings associated with the use of the efficient equipment when compared with the base equipment energy. In addition, the incremental cost for using the efficient equipment is the difference between the cost of the installed efficient equipment versus the installed base equipment.

The “early replacement” application is a more involved analysis. In this analysis, there are two timeframes that need to be analyzed. The first is the timeframe that the existing equipment would continue to operate before reaching the end of the equipment life, or the Remaining Useful Life (RUL). During the RUL of the existing equipment, the energy and demand savings gained through the use of the efficient equipment is the difference in energy and demand consumed by the efficient versus the existing equipment. Following the RUL, the second timeframe for the operation of the existing equipment is entered where the efficient equipment will continue to operate for the remainder of the equipment’s life, or the Remaining Efficient Life (REL). The REL is the difference between the EUL of the efficient equipment and the RUL of the existing equipment. During the REL of the efficient equipment, the energy and

demand savings gained through the use of the efficient equipment is the difference in energy and demand consumed by the efficient versus the base equipment that would have been installed if the existing equipment had failed.

Finally, the determination of the incremental cost associated with the “early replacement” analysis is different than that used for a “replace on fail” analysis. In the “early replacement” analysis, the incremental cost is the difference between the Net Present Value (NPV) of the efficient equipment full install cost and the NPV of the Future Value (FV) of the base equipment full installation cost.

### ***Early Replacement Applications***

## Appendix A – Technical Resource Manual

## Ameren Missouri

<i>Central Air Conditioner (CAC) Early Replacement</i>			
Efficient CAC Efficiency Rating <sup>1</sup>	SEER 14	SEER 15	SEER 16+
Efficient CAC Annual Energy Usage <sup>1</sup>	3,567.9 kWh	3,410.2 kWh	3,266.0 kWh
Efficient CAC Electric Demand <sup>1</sup>	2.202 kW	2.105 kW	2.016 kW
Efficient CAC Cost <sup>1</sup>	\$2,640	\$2,997	\$3,054
Estimated annual energy savings for RUL replacement (SEER 8 to Efficient Unit SEER) <sup>1</sup>	1,899.6 kWh	2,057.3 kWh	2,201.5 kWh
Estimated annual energy savings for REL replacement (SEER 13 to Efficient Unit SEER) <sup>1</sup>	408.5 kWh	566.1 kWh	710.4 kWh
Estimated demand savings for RUL	1.173 kW	1.270 kW	1.359 kW
Estimated demand savings for REL	0.252 kW	0.349 kW	0.439 kW
Early Replacement Incremental Cost	\$890	\$1,247	\$1,304
Current Installed CAC Efficiency <sup>1</sup>	SEER 8		
Current Installed CAC Annual Energy Usage <sup>1</sup>	5,467.5 kWh		
Current Installed CAC electric demand <sup>1</sup>	3.375 kW		
Existing Unit RUL <sup>1</sup>	6 years		
New Air Conditioner System EUL <sup>1</sup>	18 years		
REL after RUL <sup>1</sup>	12 years		
Baseline CAC Efficiency Rating <sup>1</sup>	SEER 13		
Baseline CAC Annual Energy Usage <sup>1</sup>	3,976.4 kWh		
Baseline CAC Electric Demand <sup>1</sup>	2.455 kW		
Baseline CAC Cost <sup>1</sup>	\$2,283		
UDR used for calculating Early Replacement Incremental Cost <sup>2</sup>	7.67%		
RDR used for calculating Early Replacement Incremental Cost	3.00%		

## Appendix A – Technical Resource Manual

## Ameren Missouri

[1] Taken from Morgan Measure Libraries

[2] Taken from Proctor Engineering Group

Key Assumptions:

- Savings and costs represent the entire unit
- Unit size = 3 ton

<i>Air Source Heat Pump – ASHP Base Unit Early Replacement</i>			
Efficient ASHP Efficiency Rating <sup>1</sup>	SEER 14	SEER 15	SEER 16+
Efficient ASHP Annual Energy Usage <sup>1</sup>	11,748 kWh	11,267 kWh	10,824 kWh
Efficient ASHP Electric Demand <sup>1</sup>	2.202 kW	2.105 kW	2.016 kW
Efficient ASHP Cost <sup>1</sup>	\$3,246	\$3,357	\$3,768
Estimated annual energy savings for RUL replacement (SEER 8 to Efficient Unit SEER) <sup>1</sup>	4,201.5 kWh	4,682.6 kWh	5,125.8 kWh
Estimated annual energy savings for REL replacement (SEER 13 to Efficient Unit SEER) <sup>1</sup>	1,157.5 kWh	1,638.6 kWh	2,081.8 kWh
Estimated demand savings for RUL	1.173 kW	1.270 kW	1.359 kW
Estimated demand savings for REL	0.252 kW	0.349 kW	0.439 kW
Early Replacement Incremental Cost	\$1,073	\$1,184	\$1,595
Current Installed ASHP Efficiency <sup>1</sup>	SEER 8		
Current Installed ASHP Annual Energy Usage <sup>1</sup>	15,949.2 kWh		
Current Installed ASHP electric demand <sup>1</sup>	3.375 kW		
Existing Unit RUL <sup>1</sup>	6 years		
New ASHP EUL <sup>1</sup>	18 years		
REL after RUL <sup>1</sup>	12 years		
Baseline ASHP Efficiency Rating <sup>1</sup>	SEER 13		
Baseline ASHP Annual Energy Usage <sup>1</sup>	12,905.3 kWh		

## Appendix A – Technical Resource Manual

## Ameren Missouri

<i>Air Source Heat Pump – ASHP Base Unit Early Replacement</i>	
Baseline ASHP Electric Demand <sup>1</sup>	2.455 kW
Baseline ASHP Cost <sup>1</sup>	\$2,835
UDR used for calculating Early Replacement Incremental Cost <sup>2</sup>	7.67%
RDR used for calculating Early Replacement Incremental Cost	3.00%

[1] Taken from Morgan Measure Libraries

[2] Taken from Proctor Engineering Group

## Key Assumptions:

- Savings and costs represent the entire unit
- Unit size = 3 ton

<i>Air Source Heat Pump – Electric Resistance Base Unit Early Replacement</i>			
Efficient ASHP Efficiency Rating <sup>1</sup>	SEER 14	SEER 15	SEER 16+
Efficient ASHP Annual Energy Usage <sup>1</sup>	11,748 kWh	11,267 kWh	10,824 kWh
Efficient ASHP Electric Demand <sup>1</sup>	2.202 kW	2.105 kW	2.016 kW
Efficient ASHP Cost <sup>1</sup>	\$3,246	\$3,357	\$3,768
Estimated annual energy savings for RUL replacement (SEER 8 to Efficient Unit SEER) <sup>1</sup>	14,917 kWh	15,398 kWh	15,841 kWh
Estimated annual energy savings for REL replacement (SEER 13 to Efficient Unit SEER) <sup>1</sup>	13,426 kWh	13,907 kWh	14,350 kWh
Estimated demand savings for RUL	1.173 kW	1.270 kW	1.359 kW
Estimated demand savings for REL	0.252 kW	0.349 kW	0.439 kW
Early Replacement Incremental Cost	\$1,496	\$1,607	\$2,018
Current Installed ASHP Efficiency <sup>1</sup>	SEER 8		
Current Installed ASHP Annual Energy Usage <sup>1</sup>	26,664.5 kWh		
Current Installed ASHP electric demand <sup>1</sup>	3.375 kW		

<i>Air Source Heat Pump – Electric Resistance Base Unit Early Replacement</i>	
Existing Unit RUL <sup>1</sup>	6 years
New ASHP EUL <sup>1</sup>	18 years
REL after RUL <sup>1</sup>	12 years
Baseline ASHP Efficiency Rating <sup>1</sup>	SEER 13
Baseline ASHP Annual Energy Usage <sup>1</sup>	25,173.3 kWh
Baseline ASHP Electric Demand <sup>1</sup>	2.455 kW
Baseline ASHP Cost <sup>1</sup>	\$2,283
UDR used for calculating Early Replacement Incremental Cost <sup>2</sup>	7.67%
RDR used for calculating Early Replacement Incremental Cost	3.00%

[1] Taken from Morgan Measure Libraries

[2] Taken from Proctor Engineering Group

Key Assumptions:

- Savings and costs represent the entire unit
- Unit size = 3 ton

<i>Ground Source Heat Pump Early Replacement</i>		
Efficient Ground Source Heat Pump Efficiency Rating <sup>1</sup>	SEER 14+ Replace ASHP	SEER 14+ Replace CAC w/ Elect Resist
Efficient Ground Source Heat Pump Annual Energy Usage <sup>1</sup>	10,823.5 kWh	
Efficient Ground Source Heat Pump Electric Demand <sup>1</sup>	2.016 kW	
Efficient Ground Source Heat Pump Cost <sup>1</sup>	\$7,000	
Estimated annual energy savings for RUL replacement (Installed Base to Efficient Unit SEER) <sup>1</sup>	5,125.8 kWh	15,841.0 kWh
Estimated annual energy savings for REL replacement (SEER 13 to Efficient Unit SEER) <sup>1</sup>	2,081.8 kWh	14,349.8 kWh
Estimated demand savings for RUL	1.359 kW	
Estimated demand savings for REL	0.439 kW	

<i>Ground Source Heat Pump Early Replacement</i>		
Early Replacement Incremental Cost	\$4,827	\$5,250
Current Installed ASHP or CAC Efficiency <sup>1</sup>	SEER 8	
Current Installed ASHP or CAC Annual Energy Usage <sup>1</sup>	15,949.2 kWh	26,664.5 kWh
Current Installed ASHP or CAC electric demand <sup>1</sup>	3.375 kW	
Existing Unit RUL <sup>1</sup>	6 years	
New ASHP EUL <sup>1</sup>	18 years	
REL after RUL <sup>1</sup>	12 years	
Baseline ASHP Efficiency Rating <sup>1</sup>	SEER 13	
Baseline ASHP or CAC Annual Energy Usage <sup>1</sup>	12,905.3 kWh	25,173.3 kWh
Baseline ASHP or CAC Electric Demand <sup>1</sup>	2.455 kW	
Baseline ASHP or CAC Cost <sup>1</sup>	\$2,835	\$2,283
UDR used for calculating Early Replacement Incremental Cost <sup>2</sup>	7.67%	
RDR used for calculating Early Replacement Incremental Cost	3.00%	

[1] Taken from Morgan Measure Libraries

[2] Taken from Proctor Engineering Group

Key Assumptions:

- Savings and costs represent the entire unit
- Unit size = 3 ton

<b>Concept 3 Motor Installation (ECM motor, or Brushless DC motor) Early Replacement</b>		
Efficient ECM Motor Operating Mode <sup>1</sup>	<b>Auto Fan Operation</b>	<b>Continuous Fan Operation</b>
Efficient ECM Motor Annual Energy Usage <sup>1</sup>	6,851.6 kWh	7,148.0 kWh
Efficient ECM Motore Electric Demand <sup>1</sup>	3.107 kW	
Efficient ECM Motor Cost <sup>1</sup>	\$340	
Estimated annual energy savings for RUL replacement (Older Permanent Split Capacitor motor to Efficient ECM motor) <sup>1</sup>	928.6 kWh	3,596.6 kWh
Estimated annual energy savings for REL replacement (Newer Permanent Split Capacitor motor to Efficient ECM motor) <sup>1</sup>	928.570104	3,596.6 kWh
Estimated demand savings for RUL	0.268 kW	
Estimated demand savings for REL	0.268 kW	
Early Replacement Incremental Cost	\$168	
Current Installed fan motor <sup>1</sup>	PSC Motor (Permanent Split Capacitor) for 8 SEER AC	
Current Installed PSC motor Annual Energy Usage <sup>1</sup>	7,780.2 kWh	10,744.7 kWh
Current Installed PSC motor Electric Demand <sup>1</sup>	3.375 kW	
Existing PSC motor RUL <sup>1</sup>	6 years	
New motor EUL <sup>1</sup>	18 years	
REL after RUL <sup>1</sup>	12 years	
Baseline motor type <sup>1</sup>	PSC Motor (Permanent Split Capacitor) for 13 SEER AC	
Baseline PSC motor Annual Energy Usage <sup>1</sup>	7,780.20	10,744.70
Baseline PSC motor Electric Demand <sup>1</sup>	3.375 kW	
Baseline PSC motor Cost <sup>1</sup>	\$215	
UDR used for calculating Early Replacement Incremental Cost <sup>2</sup>	7.67%	
RDR used for calculating Early Replacement Incremental Cost	3.00%	

[1] Taken from Morgan Measure Libraries

[2] Taken from Proctor Engineering Group



**Moderate Setback Thermostat**

Single Family	Current typical thermostat	No setback
	Minimum threshold for credit	Moderate setback
	Estimated savings credit <sup>1</sup>	543 kWh
	Estimated demand savings credit <sup>1</sup>	-0.02 kW
	Measure life <sup>1</sup>	9 years
	Incremental Cost <sup>1</sup>	\$ 73

[1] Taken from Morgan Measure Libraries

Key Assumptions:

- 1,900 square foot home

**Full Setback Thermostat**

Single Family	Current typical thermostat	No setback
	Minimum threshold for credit	Full setback
	Estimated savings credit <sup>1</sup>	753 kWh
	Estimated demand savings credit <sup>1</sup>	-0.02 kW
	Measure life <sup>1</sup>	9 years
	Incremental Cost <sup>1</sup>	\$ 63

Multifamily Unit	Current typical thermostat	No setback
	Minimum threshold for credit	Full setback
	Estimated savings credit <sup>2</sup>	234 kWh
	Estimated demand savings credit <sup>2</sup>	-0.09 kW
	Measure life <sup>1</sup>	9 years
	Incremental Cost <sup>1</sup>	\$ 63

[1] Taken from Morgan Measure Libraries

[2] Taken from Ameren Missouri PY 2 EMV reports

Key Assumptions:

- Single Family Dwelling Area: 1,900 square feet
- Multifamily Dwelling Area: 1,000 square feet

**Energy Star Room AC**

Single Family	Current typical CAC market	9.8 EER
	Minimum threshold for credit	10.8 EER Energy Star Room AC
	Estimated savings credit <sup>1</sup>	115 kWh
	Estimated demand savings credit <sup>2</sup>	0.094 kW
	Measure life <sup>2</sup>	12 years
	Incremental Cost <sup>2</sup>	\$ 50

Multifamily Unit	Current typical CAC market	9.8 EER
	Minimum threshold for credit	Energy Star Room AC
	Estimated savings credit <sup>1</sup>	273 kWh
	Estimated demand savings credit <sup>1</sup>	0.29 kW
	Measure life <sup>2</sup>	12 years
	Incremental Cost <sup>2</sup>	\$ 50

## Appendix A – Technical Resource Manual

## Ameren Missouri

Multifamily Unit	Current typical CAC market	10.8 EER
	Minimum threshold for credit	Energy Star Room thru-wall AC
	Estimated savings credit <sup>3</sup>	274 kWh
	Estimated demand savings credit <sup>1</sup>	0.29 kW
	Measure life <sup>2</sup>	12 years
	Incremental Cost <sup>2</sup>	\$ 50

[1] Taken from Ameren Missouri PY 2 EMV reports

[2] Taken from Morgan Measure Libraries

[3] Taken from Ameren Missouri Implementation Team of Residential HVAC program

### Air Source Heat Pump SEER 14 Replace on Fail

Single Family	Current typical ASHP	ASHP SEER 13
	Minimum threshold for credit	ASHP SEER 14
	Estimated savings credit <sup>1</sup>	1,157 kWh
	Estimated demand savings credit <sup>1</sup>	0.3 kW
	Measure life <sup>1</sup>	18 years
	Incremental Cost <sup>1</sup>	\$ 411

Single Family	Current typical CAC	Electric Resistance Furnace SEER 13
	Minimum threshold for credit	ASHP SEER 14
	Estimated savings credit <sup>1</sup>	13,426 kWh
	Estimated demand savings credit <sup>1</sup>	0.3 kW
	Measure life <sup>1</sup>	18 years
	Incremental Cost <sup>1</sup>	\$ 963

Multifamily Unit	Current typical CAC	Electric Resistance Furnace SEER 13
	Minimum threshold for credit	ASHP SEER 14
	Estimated savings credit <sup>2</sup>	244 kWh
	Estimated demand savings credit <sup>2</sup>	0.32 kW
	Measure life <sup>2</sup>	12 years
	Incremental Cost <sup>2</sup>	\$ 147

[1] Taken from Proctor Engineering Group

[2] Taken from Morgan Measure Libraries

#### Key Assumptions:

- Single Family Tons = 3.0, Multifamily Tons = 1.5
- Equivalent Full Load Hours (EFLH) Cooling = 1215 (Used by Proctor Engineering Group in their calculations - Sourced from DOE, EPA, Energy Star Calculation Sheet)
- EFLH Heating = 2009 (Used by Proctor Engineering Group in their calculations - Sourced from DOE, EPA, Energy Star Calculation Sheet)

## Appendix A – Technical Resource Manual

## Ameren Missouri

**Air Source Heat Pump SEER 15 Replace on Fail**

Single Family	Current typical ASHP	ASHP SEER 13
	Minimum threshold for credit	ASHP SEER 15
	Estimated savings credit <sup>1</sup>	1,639 kWh
	Estimated demand savings credit <sup>1</sup>	0.3 kW
	Measure life <sup>1</sup>	18 years
	Incremental Cost <sup>1</sup>	\$ 522

Single Family	Current typical CAC	Electric Resistance Furnace; SEER 13
	Minimum threshold for credit	ASHP SEER 15
	Estimated savings credit <sup>1</sup>	13,907 kWh
	Estimated demand savings credit <sup>1</sup>	0.3 kW
	Measure life <sup>1</sup>	18 years
	Incremental Cost <sup>1</sup>	\$ 1,074

Multifamily Unit	Current typical CAC	Electric Resistance Furnace; SEER 13
	Minimum threshold for credit	ASHP SEER 15
	Estimated savings credit <sup>2</sup>	437 kWh
	Estimated demand savings credit <sup>2</sup>	0.41 kW
	Measure life <sup>2</sup>	12 years
	Incremental Cost <sup>2</sup>	\$ 294

[1] Taken from Proctor Engineering Group

[2] Taken from Morgan Measure Libraries

## Key Assumptions:

- Single Family Tons = 3.0, Multifamily Tons = 1.5
- EFLH Cooling = 1215 (Used by Proctor Engineering Group in their calculations - Sourced from DOE, EPA, Energy Star Calculation Sheet)
- EFLH Heating = 2009 (Used by Proctor Engineering Group in their calculations - Sourced from DOE, EPA, Energy Star Calculation Sheet)

**Air Source Heat Pump SEER 16 Replace on Fail**

Single Family	Current typical ASHP	ASHP SEER 13
	Minimum threshold for credit	ASHP SEER 16
	Estimated savings credit <sup>1</sup>	2,082 kWh
	Estimated demand savings credit <sup>1</sup>	0.4 kW
	Measure life <sup>1</sup>	18 years
	Incremental Cost <sup>1</sup>	\$ 933

Single Family	Current typical CAC	Electric Resistance Furnace; SEER 13
	Minimum threshold for credit	ASHP SEER 16
	Estimated savings credit <sup>1</sup>	14,350 kWh
	Estimated demand savings credit <sup>1</sup>	0.4 kW
	Measure life <sup>1</sup>	18 years
	Incremental Cost <sup>1</sup>	\$ 1,485

## Appendix A – Technical Resource Manual

## Ameren Missouri

Multifamily Unit	Current typical CAC	Electric Resistance Furnace; SEER 13
	Minimum threshold for credit	ASHP SEER 16
	Estimated savings credit <sup>2</sup>	316 kWh
	Estimated demand savings credit <sup>2</sup>	0.30 kW
	Measure life <sup>2</sup>	12 years
	Incremental Cost <sup>2</sup>	\$ 441

[1] Taken from Proctor Engineering Group

[2] Taken from Morgan Measure Libraries

## Key Assumptions:

- Single Family Tons = 3.0, Multifamily Tons = 1.5
- EFLH Cooling = 1215 (Used by Proctor Engineering Group in their calculations - Sourced from DOE, EPA, Energy Star Calculation Sheet)
- EFLH Heating = 2009 (Used by Proctor Engineering Group in their calculations - Sourced from DOE, EPA, Energy Star Calculation Sheet)

**Air Source Heat Pump SEER 17 Replace on Fail**

Multifamily Unit	Current typical CAC	Electric Resistance Furnace; SEER 13
	Minimum threshold for credit	ASHP SEER 17
	Estimated savings credit <sup>1</sup>	414 kWh
	Estimated demand savings credit <sup>1</sup>	0.34 kW
	Measure life <sup>1</sup>	12 years
	Incremental Cost <sup>1</sup>	\$ 588

[1] Taken from Morgan Measure Libraries

## Key Assumptions:

- Multifamily Tons = 1.5

**Air Source Heat Pump SEER 18 Replace on Fail**

Multifamily Unit	Current typical CAC	Electric Resistance Furnace; SEER 13
	Minimum threshold for credit	ASHP SEER 18
	Estimated savings credit <sup>1</sup>	454 kWh
	Estimated demand savings credit <sup>1</sup>	0.36 kW
	Measure life <sup>1</sup>	12 years
	Incremental Cost <sup>1</sup>	\$ 735

[1] Taken from Morgan Measure Libraries

## Key Assumptions:

- Multifamily Tons = 1.5

**Central Air Conditioner SEER 14 Replace on Fail**

Single Family	Current typical CAC	SEER 13
	Minimum threshold for credit	SEER 14
	Estimated savings credit <sup>1</sup>	409 kWh
	Estimated demand savings credit <sup>1</sup>	0.25 kW
	Measure life <sup>1</sup>	18 years
	Incremental Cost <sup>1</sup>	\$ 357

## Appendix A – Technical Resource Manual

## Ameren Missouri

Multifamily Unit	Current typical CAC	SEER 13
	Minimum threshold for credit	SEER 14
	Estimated savings credit <sup>2</sup>	294 kWh
	Change in usage calculation	
	Estimated demand savings credit <sup>2</sup>	0.26 kW
	Measure life <sup>2</sup>	12 years
	Incremental Cost <sup>2</sup>	\$ 139

[1] Taken from Proctor Engineering Group

[2] Taken from Morgan Measure Libraries

### Key Assumptions:

- Single Family Tons = 3.0, Multifamily Tons = 1.5
- EFLH Cooling = 1215 (Used by Proctor Engineering Group in their calculations - Sourced from DOE, EPA, Energy Star Calculation Sheet)
- EFLH Heating = 2009 (Used by Proctor Engineering Group in their calculations - Sourced from DOE, EPA, Energy Star Calculation Sheet)

### Central Air Conditioner SEER 15 Replace on Fail

Single Family	Current typical CAC	SEER 13
	Minimum threshold for credit	SEER 15
	Estimated savings credit <sup>1</sup>	566 kWh
	Estimated demand savings credit <sup>1</sup>	0.35 kW
	Measure life <sup>1</sup>	18 years
	Incremental Cost <sup>1</sup>	\$ 714

Multifamily Unit	Current typical CAC	SEER 13
	Minimum threshold for credit	SEER 15
	Estimated savings credit <sup>2</sup>	310 kWh
	Estimated demand savings credit <sup>2</sup>	0.28 kW
	Measure life <sup>2</sup>	12 years
	Incremental Cost <sup>2</sup>	\$ 278

[1] Taken from Proctor Engineering Group

[2] Taken from Morgan Measure Libraries

### Key Assumptions:

- Single Family Tons = 3.0, Multifamily Tons = 1.5
- EFLH Cooling = 1215 (Used by Proctor Engineering Group in their calculations - Sourced from DOE, EPA, Energy Star Calculation Sheet)
- EFLH Heating = 2009 (Used by Proctor Engineering Group in their calculations - Sourced from DOE, EPA, Energy Star Calculation Sheet)

**Central Air Conditioner SEER 16 Replace on Fail**

Single Family	Current typical CAC	SEER 13
	Minimum threshold for credit	SEER 16
	Estimated savings credit <sup>1</sup>	710 kWh
	Estimated demand savings credit <sup>1</sup>	0.44 kW
	Measure life <sup>1</sup>	18 years
	Incremental Cost <sup>1</sup>	\$ 771

Multifamily Unit	Current typical CAC	SEER 13
	Minimum threshold for credit	SEER 16
	Estimated savings credit <sup>2</sup>	268 kWh
	Estimated demand savings credit <sup>2</sup>	0.18 kW
	Measure life <sup>2</sup>	12 years
	Incremental Cost <sup>2</sup>	\$ 417

[1] Taken from Proctor Engineering Group

[2] Taken from Morgan Measure Libraries

## Key Assumptions:

- Single Family Tons = 3.0, Multifamily Tons = 1.5
- EFLH Cooling = 1215 (Used by Proctor Engineering Group in their calculations - Sourced from DOE, EPA, Energy Star Calculation Sheet)
- EFLH Heating = 2009 (Used by Proctor Engineering Group in their calculations - Sourced from DOE, EPA, Energy Star Calculation Sheet)

**Central Air Conditioner SEER 17 Replace on Fail**

Multifamily Unit	Current typical CAC	SEER 13
	Minimum threshold for credit	SEER 17
	Estimated savings credit <sup>1</sup>	401 kWh
	Estimated demand savings credit <sup>1</sup>	0.32 kW
	Measure life <sup>1</sup>	12 years
	Incremental Cost <sup>1</sup>	\$ 556

[1] Taken from Morgan Measure Libraries

## Key Assumptions:

- Multifamily Tons = 1.5

**Concept 3 Continuous Fan Replace on Fail**

Current typical CAC	Energy Efficiency Ratio (EER) 8 with continuous fan
Minimum threshold for credit	Concept 3 blower motor w/ continuous fan
Estimated savings credit <sup>1</sup>	3,597 kWh
Estimated demand savings credit <sup>1</sup>	0.27 kW
Measure life <sup>1</sup>	15 years
Incremental Cost <sup>1</sup>	\$ 125

## Appendix A – Technical Resource Manual

## Ameren Missouri

[1] Taken from Proctor Engineering Group

Key Assumptions:

- EFLH Cooling = 1215 (Used by Proctor Engineering Group in their calculations - Sourced from DOE, EPA, Energy Star Calculation Sheet)
- EFLH Heating = 2009 (Used by Proctor Engineering Group in their calculations - Sourced from DOE, EPA, Energy Star Calculation Sheet)

### Concept 3 Auto Fan Replace on Fail

Current typical CAC	EER 8 with auto fan
Minimum threshold for credit	Concept 3 blower motor with auto fan
Estimated savings credit <sup>1</sup>	929 kWh
Estimated demand savings credit <sup>1</sup>	0.27 kW
Measure life <sup>1</sup>	15 years
Incremental Cost <sup>1</sup>	\$ 125

[1] Taken from Proctor Engineering Group

Key Assumptions:

- EFLH Cooling = 1215 (Used by Proctor Engineering Group in their calculations - Sourced from DOE, EPA, Energy Star Calculation Sheet)
- EFLH Heating = 2009 (Used by Proctor Engineering Group in their calculations - Sourced from DOE, EPA, Energy Star Calculation Sheet)

### Dual Fuel Heat Pump (DFHP) SEER 14 Replace on Fail

Single Family	Current typical DFHP	SEER 13; 78 Annual Fuel Utilization Efficiency ( AFUE)
	Minimum threshold for credit	SEER 14
	Estimated savings credit <sup>1</sup>	650 kWh
	Estimated demand savings credit <sup>1</sup>	0.76 kW
	Measure life <sup>1</sup>	12 years
	Incremental Cost <sup>1</sup>	\$ 254

Multifamily Unit	Current typical DFHP	SEER 13; 78 AFUE
	Minimum threshold for credit	SEER 14
	Estimated savings credit <sup>1</sup>	302 kWh
	Estimated demand savings credit <sup>1</sup>	0.32 kW
	Measure life <sup>1</sup>	12 years
	Incremental Cost <sup>1</sup>	\$ 139

[1] Taken from Morgan Measure Libraries

Key Assumptions

- Single Family Tons = 2.7, Multifamily Tons = 1.5

**Dual Fuel Heat Pump SEER 15 Replace on Fail**

Single Family	Current typical DFHP	SEER 13; 78 AFUE
	Minimum threshold for credit	SEER 15
	Estimated savings credit <sup>1</sup>	1,230 kWh
	Estimated demand savings credit <sup>1</sup>	0.80 kW
	Measure life <sup>1</sup>	12 years
	Incremental Cost <sup>1</sup>	\$ 508

Multifamily Unit	Current typical DFHP	SEER 13; 78 AFUE
	Minimum threshold for credit	SEER 15
	Estimated savings credit <sup>1</sup>	590 kWh
	Estimated demand savings credit <sup>1</sup>	0.41 kW
	Measure life <sup>1</sup>	12 years
	Incremental Cost <sup>1</sup>	\$ 278

[1] Taken from Morgan Measure Libraries

## Key Assumptions

- Single Family Tons = 2.7, Multifamily Tons = 1.5

**Dual Fuel Heat Pump SEER 16 Replace on Fail**

Single Family	Current typical DFHP	SEER 13; 78 AFUE
	Minimum threshold for credit	SEER 16
	Estimated savings credit <sup>1</sup>	1,439 kWh
	Estimated demand savings credit <sup>1</sup>	0.83 kW
	Measure life <sup>1</sup>	12 years
	Incremental Cost <sup>1</sup>	\$ 763

Multifamily Unit	Current typical DFHP	SEER 13; 78 AFUE
	Minimum threshold for credit	SEER 16
	Estimated savings credit <sup>1</sup>	492 kWh
	Estimated demand savings credit <sup>1</sup>	0.30 kW
	Measure life <sup>1</sup>	12 years
	Incremental Cost <sup>1</sup>	\$ 417

[1] Taken from Morgan Measure Libraries

## Key Assumptions

- Single Family Tons = 2.7, , Multifamily Tons = 1.5

**Dual Fuel Heat Pump SEER 17 Replace on Fail**

Single Family	Current typical DFHP	SEER 13; 78 AFUE
	Minimum threshold for credit	SEER 17
	Estimated savings credit <sup>1</sup>	1,651 kWh
	Estimated demand savings credit <sup>1</sup>	0.81 kW
	Measure life <sup>1</sup>	12 years
	Incremental Cost <sup>1</sup>	\$ 1,017



Multifamily Unit	Current typical DFHP	SEER 13; 78 AFUE
	Minimum threshold for credit	SEER 17
	Estimated savings credit <sup>1</sup>	667 kWh
	Estimated demand savings credit <sup>1</sup>	0.34 kW
	Measure life <sup>1</sup>	12 years
	Incremental Cost <sup>1</sup>	\$ 556

[1] Taken from Morgan Measure Libraries

#### Key Assumptions

- Single Family Tons = 2.7, Multifamily Tons = 1.5

#### *Dual Fuel Heat Pump SEER 18 Replace on Fail*

Single Family	Current typical DFHP	SEER 13; 78 AFUE
	Minimum threshold for credit	SEER 18
	Estimated savings credit <sup>1</sup>	1,638 kWh
	Estimated demand savings credit <sup>1</sup>	0.88 kW
	Measure life <sup>1</sup>	12 years
	Incremental Cost <sup>1</sup>	\$ 1,342

Multifamily Unit	Current typical DFHP	SEER 13; 78 AFUE
	Minimum threshold for credit	SEER 18
	Estimated savings credit <sup>1</sup>	681 kWh
	Estimated demand savings credit <sup>1</sup>	0.36 kW
	Measure life <sup>1</sup>	12 years
	Incremental Cost <sup>1</sup>	\$ 734

[1] Taken from Morgan Measure Libraries

#### Key Assumptions

- Single Family Tons = 2.7, Multifamily Tons = 1.5

#### *Duct Insulation*

Multifamily Unit	Current typical duct system	Ducts not insulated
	Minimum threshold for credit	Insulate ducts
	Estimated savings credit <sup>1</sup>	460 kWh
	Estimated demand savings credit <sup>1</sup>	0.15 kW
	Measure life <sup>1</sup>	20 years
	Incremental Cost <sup>1</sup>	\$ 528

[1] Taken from Morgan Measure Libraries

#### Key Assumptions:

- 2,200 square feet

## Appendix A – Technical Resource Manual

## Ameren Missouri

**Duct Location**

Multifamily Unit	Current typical duct system	Ducts outside conditioned space
	Minimum threshold for credit	Relocate ducts
	Estimated savings credit <sup>1</sup>	852 kWh
	Estimated demand savings credit <sup>1</sup>	0.43 kW
	Measure life <sup>1</sup>	20 years
	Incremental Cost <sup>1</sup>	\$ 1,650

[1] Taken from Morgan Measure Libraries

Key Assumptions:

- 2,200 square foot home

**Duct Sealing Level 1**

Single Family	Current typical ducted air distribution system	Substantial Leakage
	Minimum threshold for credit	14% Duct leakage improvement
	Estimated savings credit <sup>1</sup>	1,352 kWh
	Estimated demand savings credit <sup>1</sup>	0.24 kW
	Measure life <sup>1</sup>	20 years
	Incremental Cost <sup>1</sup>	\$ 325

Multifamily Unit	Current typical ducted air distribution system	Substantial Leakage
	Minimum threshold for credit	20% Duct leakage improvement
	Estimated savings credit <sup>2</sup>	250 kWh
	Estimated demand savings credit <sup>2</sup>	0.08 kW
	Measure life <sup>2</sup>	18 years
	Incremental Cost <sup>2</sup>	\$ 475

[1] Taken from Proctor Engineering Group

[2] Taken from Morgan Measure Libraries

Key Assumptions:

- 2,200 square feet (for both single family and multifamily)

**Duct Sealing Level 2**

Single Family	Current typical ducted air distribution system	Substantial Leakage
	Minimum threshold for credit	50% Duct leakage improvement
	Estimated savings credit <sup>1</sup>	2,347 kWh
	Estimated demand savings credit <sup>1</sup>	0.42 kW
	Measure life <sup>1</sup>	20 years
	Incremental Cost <sup>1</sup>	\$ 325

Multifamily Unit	Current typical ducted air distribution system	Substantial Leakage
	Minimum threshold for credit	25% Duct leakage improvement
	Estimated savings credit <sup>2</sup>	338 kWh
	Estimated demand savings credit <sup>2</sup>	0.10 kW
	Measure life <sup>2</sup>	18 years
	Incremental Cost <sup>2</sup>	\$ 475

## Appendix A – Technical Resource Manual

## Ameren Missouri

[1] Taken from Proctor Engineering Group

[2] Taken from Morgan Measure Libraries

Key Assumptions:

- 2,200 square feet (for both single family and multifamily)

### Duct Sealing Level 3

Multifamily Unit	Current typical ducted air distribution system	Substantial Leakage
	Minimum threshold for credit	30% Duct leakage improvement
	Estimated savings credit <sup>2</sup>	424 kWh
	Estimated demand savings credit <sup>2</sup>	0.13 kW
	Measure life <sup>2</sup>	18 years
	Incremental Cost <sup>2</sup>	\$ 475

[1] Taken from Proctor Engineering Group

[2] Taken from Morgan Measure Libraries

Key Assumptions:

- 2,200 square feet

### Electronically Commutated Motor Blower – Continuous

Multifamily Unit	Current typical motor	Standard motor continuous operation
	Minimum threshold for credit	Continuous ECM blower
	Estimated savings credit <sup>1</sup>	794 kWh
	Estimated demand savings credit <sup>1</sup>	0.14 kW
	Measure life <sup>1</sup>	15 years
	Incremental Cost <sup>1</sup>	\$ 263

[1] Taken from Morgan Measure Libraries

Key Assumptions:

- Multifamily Tons = 1.5

### Electronically Commutated Motor Blower – Intermittent

Multifamily Unit	Current typical motor	Standard motor continuous operation
	Minimum threshold for credit	Intermittent ECM blower
	Estimated savings credit <sup>1</sup>	190 kWh
	Estimated demand savings credit <sup>1</sup>	0.11 kW
	Measure life <sup>1</sup>	15 years
	Incremental Cost <sup>1</sup>	\$ 263

[1] Taken from Morgan Measure Libraries

Key Assumptions:

- Multifamily Tons = 1.5

## Appendix A – Technical Resource Manual

## Ameren Missouri

### Ground Source Heat Pump SEER 14 Replace on Fail

Current typical heating equipment	Electric Resistance Furnace SEER 13
Minimum threshold for credit	Ground Source Heat Pump SEER 14
Estimated savings credit <sup>1</sup>	14,350 kWh
Estimated demand savings credit <sup>1</sup>	0.44 kW
Measure life <sup>1</sup>	18 years
Incremental Cost <sup>1</sup>	\$ 4,717

[1] Taken from Proctor Engineering Group

#### Key Assumptions

- Tons = 3.0

### Heat Pump Strip Heat Lock Out Installed

Current typical heat pump system	No heat pump control dial installed
Minimum threshold for credit	Heat pump strip control dial installed
Estimated savings credit <sup>1</sup>	1,332 kWh
Estimated demand savings credit <sup>1</sup>	0.47 kW
Measure life <sup>1</sup>	15 years
Incremental Cost <sup>1</sup>	\$ 154

[1] Taken from Proctor Engineering Group

#### Key Assumptions

- Tons = 3.0

### Heat Pump Strip Heat Lock Out Reset

Current typical heat pump system	Heat pump control dial installed, but not set
Minimum threshold for credit	Heat pump strip lock out installed
Estimated savings credit <sup>1</sup>	1,332 kWh
Estimated demand savings credit <sup>1</sup>	0.47 kW
Measure life <sup>1</sup>	15 years
Incremental Cost <sup>1</sup>	\$ 25

[1] Taken from Proctor Engineering Group

#### Key Assumptions

- Tons = 3.0

### HVAC Maintenance and Tune-Up

Single Family	Current typical HVAC system	10% EER degradation; 5% furnace efficiency degradation
	Minimum threshold for credit	HVAC maintenance and tune-up
	Estimated savings credit <sup>1</sup>	174 kWh
	Estimated demand savings credit <sup>1</sup>	0.21 kW
	Measure life <sup>1</sup>	10 years
	Incremental Cost <sup>1</sup>	\$ 130

Multifamily Unit	Current typical HVAC system	10% EER degradation; 5% furnace efficiency degradation
	Minimum threshold for credit	HVAC maintenance and tune-up
	Estimated savings credit <sup>1</sup>	75 kWh
	Estimated demand savings credit <sup>1</sup>	0.09 kW
	Measure life <sup>1</sup>	10 years
	Incremental Cost <sup>1</sup>	\$ 70

[1] Taken from Morgan Measure Libraries

#### Key Assumptions

- Single Family Tons = 2.7, Multifamily Tons = 1.5

#### Indoor Coil Cleaning

Current typical air conditioning or heat pump system	Dirty coils
Minimum threshold for credit	Coil cleaning
Estimated savings credit <sup>1</sup>	638 kWh
Estimated demand savings credit <sup>1</sup>	0.23 kW
Measure life <sup>1</sup>	5 years
Incremental Cost <sup>1</sup>	\$ 63

[1] Taken from Proctor Engineering Group

#### Key Assumptions

- Tons = 3.0

#### Outdoor Coil Cleaning

Current typical air conditioning or heat pump system	Dirty coils
Minimum threshold for credit	Coil cleaning
Estimated savings credit <sup>1</sup>	515 kWh
Estimated demand savings credit <sup>1</sup>	0.18 kW
Measure life <sup>1</sup>	5 years
Incremental Cost <sup>1</sup>	\$ 31

[1] Taken from Proctor Engineering Group

#### Key Assumptions

- Tons = 3.0

#### Packaged Terminal Air Conditioner (PTAC) EER 9.3 Replace on Fail

Current typical PTAC	EER 7.1
Minimum threshold for credit	EER 9.3
Estimated savings credit <sup>1</sup>	213 kWh
Estimated demand savings credit <sup>1</sup>	0.20 kW
Measure life <sup>1</sup>	15 years
Incremental Cost <sup>1</sup>	\$ 136

[1] Taken from Morgan Measure Libraries

#### Key Assumptions

- Tons = 0.8

## Appendix A – Technical Resource Manual

## Ameren Missouri

### Packaged Terminal Air Conditioner EER 10.3 Replace on Fail

Current typical PTAC	EER 8.7
Minimum threshold for credit	EER 10.3
Estimated savings credit <sup>1</sup>	133 kWh
Estimated demand savings credit <sup>1</sup>	0.11 kW
Measure life <sup>1</sup>	15 years
Incremental Cost <sup>1</sup>	\$ 124

[1] Taken from Morgan Measure Libraries

#### Key Assumptions

- Tons = 0.8

### Packaged Terminal Heat Pump (PTHP) EER 9.1 Replace on Fail

Current typical PTHP	EER 7.0
Minimum threshold for credit	EER 9.1
Estimated savings credit <sup>1</sup>	336 kWh
Estimated demand savings credit <sup>1</sup>	0.20 kW
Measure life <sup>1</sup>	15 years
Incremental Cost <sup>1</sup>	\$ 169

[1] Taken from Morgan Measure Libraries

#### Key Assumptions

- Tons = 0.8

### Packaged Terminal Heat Pump EER 10.9 Replace on Fail

Current typical PTHP	EER 8.5
Minimum threshold for credit	EER 10.9
Estimated savings credit <sup>1</sup>	244 kWh
Estimated demand savings credit <sup>1</sup>	0.15 kW
Measure life <sup>1</sup>	15 years
Incremental Cost <sup>1</sup>	\$ 155

[1] Taken from Morgan Measure Libraries

#### Key Assumptions

- Tons = 0.8

### Refrigerant Charge Adjustment

Single Family	Current typical system	10% EER degradation
	Minimum threshold for credit	Correct charge
	Estimated savings credit <sup>1</sup>	191 kWh
	Estimated demand savings credit <sup>1</sup>	0.23 kW
	Measure life <sup>1</sup>	10 years
	Incremental Cost <sup>1</sup>	\$ 127

## Appendix A – Technical Resource Manual

## Ameren Missouri

Multifamily	Current typical system	5% EER degradation
	Minimum threshold for credit	Correct charge
	Estimated savings credit <sup>1</sup>	44 kWh
	Estimated demand savings credit <sup>1</sup>	0.06 kW
	Measure life <sup>1</sup>	10 years
	Incremental Cost <sup>1</sup>	\$ 58

Multifamily	Current typical system	10% EER degradation
	Minimum threshold for credit	Correct charge
	Estimated savings credit <sup>1</sup>	87 kWh
	Estimated demand savings credit <sup>1</sup>	0.12 kW
	Measure life <sup>1</sup>	10 years
	Incremental Cost <sup>1</sup>	\$ 70

Multifamily	Current typical system	15% EER degradation
	Minimum threshold for credit	Correct charge
	Estimated savings credit <sup>1</sup>	131 kWh
	Estimated demand savings credit <sup>1</sup>	0.18 kW
	Measure life <sup>1</sup>	10 years
	Incremental Cost <sup>1</sup>	\$ 219

[1] Taken from Morgan Measure Libraries

## Key Assumptions

- Tons = 2.7

**Air Sealing (Infiltration Reduction) Level 1**

Current typical system	Varies by vintage
Minimum threshold for credit	Reduce air leakage 30%
Estimated savings credit <sup>1</sup>	448 kWh
Estimated demand savings credit <sup>1</sup>	0.07 kW
Measure life <sup>1</sup>	13 years
Incremental Cost <sup>1</sup>	\$ 264

[1] Taken from Morgan Measure Libraries

## Key Assumptions

- Tons = 2.2

**Air Sealing (Infiltration Reduction) Level 2**

Current typical system	Varies by vintage
Minimum threshold for credit	Reduce air leakage 50%
Estimated savings credit <sup>1</sup>	740 kWh
Estimated demand savings credit <sup>1</sup>	0.12 kW
Measure life <sup>1</sup>	13 years
Incremental Cost <sup>1</sup>	\$ 264

[1] Taken from Morgan Measure Libraries

Key Assumptions

- Tons = 2.2

## **Residential Appliances**

### ***Appliance Recycling***

Ameren Missouri considered 3 measures for an Appliance Recycling program. All 3 measures were associated with different residential end uses: refrigeration, freezer, and miscellaneous. These measures are different than other measures in the TRM because the efficient characteristics assume a complete removal of the base characteristic. The incremental cost for each appliance recycling measure is the actual cost associated with the removal and recycling of the retired unit.

The energy and demand savings for the freezer and refrigerator recycling measures can be calculated using the following formula:



## Appendix A – Technical Resource Manual

## Ameren Missouri

The Energy Star refrigerator measure is associated with the residential refrigeration end use. The energy savings equation was taken from Ameren Missouri's PY 2 EMV reports. The following table summarizes the measure level energy savings, demand savings, incremental cost, and effective useful life.

Current typical existing market (baseline)	Operating unit with top freezer (15, 18, or 21 ft <sup>3</sup> ) manufactured before 2000
Minimum threshold for credit	Energy Star Refrigerator in Multifamily Unit
Estimated savings credit for Energy Star Refrigerator <sup>1</sup>	1,126 kWh
Change in usage calculation <sup>1</sup>	
Estimated demand savings credit for installing Energy Star Refrigerator <sup>1</sup>	0.1778 kW
Measure life	10 years
Incremental Cost <sup>1</sup>	\$ 680

[1] Taken from Ameren Missouri PY 2 EMV Report

\*- If the appropriate field data required to complete this equation cannot be obtained, the deemed savings values in the table are to be used for each measure.

### Key Assumptions

- Base UEC = 1,495 kWh
- Efficient UEC = 369 kWh

Note, this savings value is only for multi-family units, savings for single family units, while similar, may be slightly different due to various factors including as household size, location of unit, or climate. Another tool to help estimate savings is the Energy Star website which provides various unit models and associated energy consumption.

[http://www.energystar.gov/index.cfm?fuseaction=find\\_a\\_product.showProductGroup&pgw\\_code=RF](http://www.energystar.gov/index.cfm?fuseaction=find_a_product.showProductGroup&pgw_code=RF)

### Energy Star Freezer

The Energy Star freezer measure is associated with the residential refrigeration end use. The energy savings equation was taken from Ameren Missouri's PY 2 EMV reports. The following table summarizes the measure level energy savings, demand savings, incremental cost, and effective useful life.

Current typical existing market (baseline)	Standard Freezer
Minimum threshold for credit	Energy Star Freezer
Estimated savings credit for Energy Star Freezer <sup>1</sup>	61 kWh
Estimated demand savings credit for installing Energy Star Freezer <sup>1</sup>	0.004 kW
Measure life <sup>1</sup>	11 years
Incremental Cost <sup>1</sup>	\$ 33

[1] Taken from Ameren Missouri PY 2 EMV Report

### Energy Room Air Purifier

The Energy Star air purifier measure is associated with the residential miscellaneous end use. The energy savings equation was taken from Ameren Missouri's PY 3 EMV reports. The following table summarizes the measure level energy savings, demand savings, incremental cost, and effective useful life.

## Appendix A – Technical Resource Manual

## Ameren Missouri

Current typical existing market (baseline)	Standard Air Purifier
Minimum threshold for credit	Energy Star Air Purifier
Estimated savings credit for Energy Star Air Purifier <sup>1</sup>	482 kWh
Estimated demand savings credit for installing Energy Star Air Purifier <sup>1</sup>	0.0813 kW
Measure life <sup>1</sup>	9 years
Incremental Cost <sup>1</sup>	\$ 70

[1] Taken from Ameren Missouri PY 3 EMV Report. Updated calculations using Air Purifier Energy Star calculator.

Key Assumptions:

- Unit Size = CADR(clean air delivery rate)

CADR	Annual Energy Savings (kWh)	Qty	Weight
51-100 (75)	293	352	34%
101-150 (125)	488	508	48%
151-200 (175)	683	117	11%
201-250 (225)	877	10	1%
Over 250 (275)	1,072	61	6%
Not listed	482.08*	460	N/A

\* Savings are the weighted average savings for the products included in the ENERGY STAR QPL.

Information taken from the Energy Star calculator found here:

[http://www.energystar.gov/index.cfm?fuseaction=find\\_a\\_product.showProductGroup&pgw\\_code=RAC](http://www.energystar.gov/index.cfm?fuseaction=find_a_product.showProductGroup&pgw_code=RAC)

### Refrigerator Coil Cleaning Brush

The refrigerator coil cleaning brush is a device used to clean the coils underneath a refrigerator. This device will be initially used during the low income program by the program administrator, and subsequently left behind for customers to use.

Current typical existing market (baseline)	No Brush
Minimum threshold for credit	Coil Cleaner Brush
Estimated savings credit <sup>1</sup>	16.5 kWh
Estimated demand savings credit <sup>1</sup>	0.0773 kW
Measure life <sup>1</sup>	2 years
Incremental Cost <sup>1</sup>	\$ 3

[1] Taken from Honeywell Low Income proposal October 2012.

Key Assumptions:

- 3% of annual refrigerator annual kWh consumption
- Annual refrigerator consumption = 550 kWh based on the average Federal Standard kWh/year

### Energy Star Water Cooler

The Energy Star water cooler measure is associated with the residential refrigeration end use. The energy savings equation was taken from Ameren Missouri's PY 3 EMV reports. The following table

## Appendix A – Technical Resource Manual

## Ameren Missouri

summarizes the measure level energy savings, demand savings, incremental cost, and effective useful life.

Current typical existing market (baseline)	Standard Water Cooler
Minimum threshold for credit	Energy Star Water Cooler
Estimated savings credit for Energy Star Water Cooler Cold Only <sup>1</sup>	47 kWh
Estimated savings credit for Energy Star Water Cooler Hot and Cold <sup>1</sup>	361 kWh
Estimated demand savings credit for installing Energy Star Water Cooler Cold Only <sup>1</sup>	0.233 kW
Estimated demand savings credit for installing Energy Star Water Cooler Hot and Cold <sup>1</sup>	.001 kW
Measure life <sup>1</sup>	10 years
Incremental Cost <sup>1</sup>	\$ 17

[1] Taken from Ameren Missouri PY 3 EMV Report

### Key Assumptions:

- 365 days per year
- Conventional Hot and Cold energy consumption = 2.19 kWh/day
- Conventional Cold Water Only energy consumption = 0.29 kWh per day
- Efficient Hot and Cold energy consumption = 1.2 kWh per day.
- Efficient Cold Water Only energy consumption = 0.16 kWh per day
- Blend of hot and cold, and cold only water coolers. 98% are assumed to be combination and 2% are cold only.

Unit Type	Annual Energy Savings (kWh)	Qty	Weight
Hot and Cold	361	508	98%
Cold only*	47	9	2%

\* This category includes "Cook and Cold" units.

Information taken from the Energy Star calculator found here:

[http://www.energystar.gov/index.cfm?fuseaction=find\\_a\\_product.showProductGroup&pgw\\_code=WA](http://www.energystar.gov/index.cfm?fuseaction=find_a_product.showProductGroup&pgw_code=WA)

### Smart Strip Plug Outlet

The smart strip plug outlet measure is associated with the residential miscellaneous end use. All of the parameters for the smart strip plug outlet were taken from Morgan Measure Libraries. Morgan Measure Libraries methodology for calculating the savings for smart strips considered idle wattages for computer and television peripherals and took an average of both peripheral systems. Morgan Measure Libraries considered the computer peripherals to include: speakers, ink-jet printer, internet terminal and phone/fax/copier. Morgan Measure Libraries considered the television peripherals to include: audio system/ speakers, DVD player, VCR, cable box, and video game console.

The energy and demand savings for the smart strip measure can be calculated using the following formulae:

If the appropriate field data required to complete this equation cannot be obtained, the deemed savings values in the following table are to be used for each measure.

Current typical existing market (baseline)	Standard Plug +Outlet
Minimum threshold for credit	Smart Strip Plug Outlet
Estimated savings credit for smart strip <sup>1</sup>	184 kWh
Estimated demand savings credit for installing smart strip <sup>1</sup>	0.0261 kW
Measure life	5 years
Incremental Cost <sup>1</sup>	\$ 40

[1] Taken from Morgan Measure Libraries

#### Key Assumptions:

- Idle Watts = average energy used by system when in standby mode and computer or TV is turned off
- Efficient Idle Watts = average energy used by system when in standby mode and computer or TV is turned off
- Idle Hours per day = hours per day when system is assumed to be turned off = 19.5

#### **Pool Pump and Motor**

The pool pump and motor measures are associated with the business motors end use. All of the parameters for the pool pump and motor measures were taken from Morgan Measure Libraries. For each of the measures steady state operation was assumed. A base case and an improved case was calculated for each measure and the power reduction was taken as the average power reduction in the case of the single speed measure or the time weighted average power reduction in the case of the dual speed measure. A coincidence factor of 50% was used for peak savings. Morgan Measure libraries assumed a swimming season duration of May 1 through September 30. Morgan Measure libraries assumed the average pool volume is 25,000 gallons.

The energy and demand savings for the smart strip measure can be calculated using the following formulae:

#### **Single Speed High Efficiency Pool Pump**

Current typical existing market (baseline)	Standard Pool Pump and Motor Efficiency
Minimum threshold for credit	Single Flow High Efficiency Pool Pump and Motor with Controls
Estimated savings credit for efficient pool pump <sup>1</sup>	694 kWh
Change in use calculation <sup>2</sup>	See equation below.
Estimated demand savings credit for efficient pool pump <sup>1</sup>	0.357 kW
Measure life <sup>1</sup>	10 years
Incremental Cost <sup>1</sup>	\$ 85

[1] Taken from Morgan Measure Libraries

[2] Taken from Ohio TRM 2010

\*- If the appropriate field data required to complete this equation cannot be obtained, the deemed savings values in the table are to be used for each measure.

- LFB<sub>Base</sub> = Load factor of baseline motor
- LFEff<sub>1</sub> = Load factor of two speed motor at slow speed = 55% delta
- LFEff<sub>2</sub> = Load factor of two speed motor at high speed = 1%delta
- $\eta$ Pump<sub>Base</sub> = Efficiency of baseline motor
- $\eta$ PumpEff<sub>1</sub> = Efficiency of two speed motor at slow speed = 5% delta
- $\eta$ PumpEff<sub>2</sub> = Efficiency of two speed motor at high speed = 13% delta
- AOH<sub>Base</sub> = Assumed annual operating hours of baseline pump
- AOHEff<sub>1</sub> = Assumed annual hours of two speed pump at low speed = 918
- AOHEff<sub>2</sub> = Assumed annual hours of two speed pump at high speed = 918
- HP<sub>1</sub> = Pump horse power = 0.12 delta
- CF = conversion factor = 0.746
- HP<sub>2</sub> = Pump horse power = 0.0 delta
- CF = conversion factor = 0.746

***Variable Frequency Drive (VFD) on Swimming Pool Pump***

The VFD on swimming pool pump measure is associated with the residential pool spa end use.

The energy and demand savings for the VFD on swimming pool pump measure can be calculated using the following formulae:

## Appendix A – Technical Resource Manual

## Ameren Missouri

[1]Information taken from Morgan Measure Library

### Multi Family Window Replacement

Current typical existing market (baseline)	Varies by Vintage
Minimum threshold for credit	SHGC = 0.4, U = 0.35
Estimated savings credit for efficient windows <sup>1</sup>	2,140 kWh
Estimated demand savings credit for efficient windows <sup>1</sup>	0.692 kW
Measure life <sup>1</sup>	20 years
Incremental Cost <sup>1</sup>	\$ 1,500

[1]Information taken from Morgan Measure Library

### Multi Family Window Film

Current typical existing market (baseline)	SHGC = .39; U=.72
Minimum threshold for credit	2 pane clear; SHGC = .73; U=.72
Estimated savings credit for efficient windows <sup>1</sup>	325 kWh
Estimated demand savings credit for efficient windows <sup>1</sup>	0.626 kW
Measure life <sup>1</sup>	10 years
Incremental Cost <sup>1</sup>	\$ 538

[1]Information taken from Morgan Measure Library

### Ceiling Insulation

Current typical existing market (baseline)	R-19 or below
Minimum threshold for credit	R-30 or above
Estimated savings credit <sup>1</sup>	See table below
Estimated demand savings credit <sup>1</sup>	See table below
Measure life <sup>1</sup>	25 years
Incremental Cost <sup>2</sup>	See Table Below

[1] Information taken Illinois TRM 2012.

[2] Information gathered from Missouri insulation contractors participating in Ameren Missouri's natural gas incentive program.

Efficient	Baseline	kWh	kW	Electric Incremental Cost*	Full Incremental Cost**
R-30	R-5	433.9	0.3	\$ 75	\$ 475
R-38	R-5	452.2	0.3	\$ 86	\$ 550
R-49	R-5	467.6	0.4	\$ 104	\$ 665
R-30	R-11	149.9	0.1	\$ 66	\$ 420
R-38	R-11	168.2	0.1	\$ 78	\$ 495
R-49	R-11		0.1	\$ 94	\$ 600



## Appendix A – Technical Resource Manual

## Ameren Missouri

		183.6			
R-30	R-19	50.2	0.0	\$ 54	\$ 345
R-38	R-19	68.5	0.1	\$ 66	\$ 420
R-49	R-19	83.9	0.1	\$ 82	\$ 525

\*-This measure is intended to be included within Ameren Missouri's Home Energy Performance program. Since this program seeks to glean both electric and natural gas savings from Ameren Missouri customers receiving both fuel services from the Company, the incremental costs are parsed on a source BTU basis between natural gas and electric fuels. This is done by multiplying annual CCF savings by 100,000 and electric annual kWh savings by 10,000. As an example, ceiling insulation with a baseline of R-5 and an efficient of R-30 saves 433.9 kWh and 227.6 therms. Multiply therm savings by 1.024 to convert to CCF,  $227.5 * 1.024 = 233$ . This yields 4,339,268 source BTU electric and 23,303,097 source BTU gas, or 15.7% electric and 84.3% gas. Multiplying the full incremental cost of  $\$475 * 15.7\% = \$75$ .

\*\*-Incremental cost is assuming 950 square feet times the appropriate R-value differential in "Insulation Cost Table." These cost estimates were gathered from Missouri based insulation contractors.

## Key Assumptions

AC SEER	10	based on Illinois TRM 2012
Furnace AFUE	70%	based on Illinois TRM 2012
Baseline R-value	See Above	
Efficient R-value	See Above	
Framing factor	0.15	
Ceiling Area (sq ft)	950	based on 2009 DSM potential study home size of 1900 sq ft
Lifetime	25	years based off Illinois TRM
CDD	1646	NOAA @65 degrees @ Lambert
HDD	4535	NOAA @65 degrees @ Lambert
FLH_cool	1215	based on Energy Star calculator St Louis
System Coincidence Factor	0.915	based on Illinois TRM Belleville Area
	100,067	Btu/therm

$$= [(1/R_{old} - 1/R_{attic}) * A_{attic} * (1 - Framing\_factor/2) * 24 * CDD] / (1000 * \eta_{Cool})$$

R\_attic = R-value of new attic assembly (including all layers between inside air and outside air).

R\_old = R-value value of existing assemble and any existing insulation. (Minimum of R-5 for uninsulated assemblies<sup>2</sup>)

A\_attic = Total area of insulated ceiling/attic (ft<sup>2</sup>)

Framing\_factor = Adjustment to account for area of framing  
= 15%<sup>3</sup>

<sup>2</sup> An estimate based on review of Madison Gas and Electric, Exterior Wall Insulation, R-value for no insulation in walls, and NREL's Building Energy Simulation Test for Existing Homes (BESTEST-EX).

<sup>3</sup> Based on Oak Ridge National Lab, Technology Fact Sheet for Wall Insulation. Factor is used directly for walls, but

- 24 = Converts hours to days  
 CDD = Cooling Degree Days  
 = dependent on location<sup>4</sup>:  
 1000 = Converts Btu to kBtu  
 $\eta_{Cool}$  = Seasonal Energy Efficiency Ratio of cooling system (kBtu/kWh)  
 = Actual (where it is possible to measure or reasonably estimate). If unknown assume the following<sup>5</sup>:

Age of Equipment	$\eta_{Cool}$ Estimate
Before 2006	10
After 2006	13

Insulation Cost Table		
Starting Baseline Insulation	Upgraded Insulation	\$/sf cellulose
R-5	R-30	\$ 0.50
R-5	R-38	\$ 0.58
R-5	R-49	\$ 0.70
R-11	R-30	\$ 0.44
R-11	R-38	\$ 0.52
R-11	R-49	\$ 0.63
R-19	R-30	\$ 0.36
R-19	R-38	\$ 0.44
R-19	R-49	\$ 0.55

In order to appropriately parse costs and savings, the following natural gas savings equations can be utilized.

$$= [(1/R_{old} - 1/R_{attic}) * A_{attic} * (1 - Framing\_factor/2) * 24 * HDD] / (100,067 * \eta_{Heat})$$

$\eta_{Heat}$  = Efficiency of heating system. Use actual, if unknown assume 70%.

## Residential Water Heating

### Water Heater

Water heater efficiency is rated according to its Energy Factor (EF). For residential storage tank electric water heaters, the current minimum standard requires an EF of 0.90 or greater. Heat Pump Water Heaters (HPWH) take heat from the surrounding air and transfer it to the water in the tank, unlike

---

reduced by 1/2 for attics, assuming that the average joist is 5.5" and R-38 requires 11" of cellulose, therefore at each joist, 1/2 the thickness of insulation has been added as between the joists.

<sup>4</sup> National Climatic Data Center, Cooling Degree Days are based on a base temp of 65°F. There is a county mapping table in the Appendix providing the appropriate city to use for each county of Illinois.

<sup>5</sup> These default system efficiencies are based on the applicable minimum Federal Standards. In 2006 the Federal Standard for Central AC was adjusted. While one would expect the average system efficiency to be higher than this minimum, the likely degradation of efficiencies over time mean that using the minimum standard is appropriate.

conventional water heaters, which use either gas (or sometimes other fuels) burners or electric resistance heating coils to heat the water. HPWH technology uses a standard heat pump thermodynamic cycle to remove energy from a low-temperature heat source (the ambient room air) and transfer it to a high-temperature heat sink (the water within the heater). Most HPWHs have back up heating elements to heat the water during very low temperature periods and come either self-contained with a storage tank or as an add-on unit using a conventional water heater for storage.

The energy and demand savings for each residential water heater measure can be calculated using the following formulae:

[1] Taken from Morgan Measure Libraries

***Water Heater Blankets***

Water heater blankets having an R value of 11 when wrapped around electric water heaters. The energy savings equation for a water heater blanket was taken from Ameren Missouri's Multifamily PY2 Report.

## Appendix A – Technical Resource Manual

## Ameren Missouri

The following table summarizes the measure level energy savings, demand savings, incremental cost, and effective useful life.

Efficient Characteristics		Base Characteristics					
Description	Measure Life	Description	$\Delta$ UA	$\Delta$ Temp (°F)	Estimated Annual Energy Savings (kWh)	Estimated Annual Demand Savings (kW)	Incremental Cost
Electric Water Heater Tank Blanket Insulation, R-5 for Single Family Dwelling <sup>1</sup>	10	Water Heater with No Insulation	1.24	56.5	180	0.02	\$18.00
Electric Water Heater Tank Blanket Insulation, R-5 for Multifamily Dwelling <sup>2</sup>	15	Water Heater with No Insulation	0.14	56.5	33	0.00	\$18.00

[1] Taken from Morgan Measure Libraries. Morgan was appended to include information from Cadmus.

[2] Based on Ameren Missouri PY 2 EMV report.

[3] Pennsylvania TRM 2012.

### Water Heater Thermostat Set-back

Current typical existing market (baseline)	Electric Water Heater Thermostat set at 135°F
Minimum threshold for credit	Electric Water Heater Thermostat set at 120°F
Estimated savings credit for water heater set-back <sup>1</sup>	163 kWh
Estimated demand savings credit for water heater set-back <sup>1</sup>	0.02 kW
Measure life <sup>1</sup>	4 years
Incremental Cost <sup>1</sup>	\$ 8

[1] Taken from Morgan Measure Libraries (Cadmus Potential Study measure list)

#### Key Assumptions

- Assumes a 40 gallon residential tank

### Geothermal Heat Pump Desuperheater

The energy savings equation was taken from Morgan Measure Libraries. Morgan was appended to include information from Cadmus to include information for a geothermal heat pump desuperheater. The following table summarizes the measure level energy savings, demand savings, incremental cost, and effective useful life.

Current typical existing market (baseline)	No Desuperheater
Minimum threshold for credit	Electric Water Heater Thermostat set at 120°F
Estimated savings credit for desuperheater <sup>1</sup>	1,540 kWh
Estimated demand savings credit for efficient desuperheater <sup>1</sup>	0.17 kW
Measure life <sup>1</sup>	10 years
Incremental Cost <sup>1</sup>	\$ 239

[1] Taken from Morgan Measure Libraries (Cadmus Potential Study measure list)

***Pipe Wrap***

The energy savings equation for pipe wrap was taken from Ameren Missouri's Multifamily PY2 Report.

## Appendix A – Technical Resource Manual

## Ameren Missouri

- Days = number of days per year a shower is taken, 365
- $\Delta$ GPM = difference in gallons per minute for the base showerhead and the new showerhead
- $\Delta$ Temp = difference in temperatures of the shower water and the water main
- EF = energy factor of the water heater
- Number of Units = number of showerheads in home = 1
- 409.7 = a constant derived from  $3,413/8.33$

Note: the savings values have only been evaluated for multifamily units. It is likely there will be savings differences between multifamily and single family residences.

The following table summarizes the measure level energy savings, demand savings, incremental cost, and effective useful life.

Efficient Characteristics		Base Characteristics					
Description	Measure Life	Description	$\Delta$ GPM	$\Delta$ Temp (°F)	Estimated Annual Energy Savings (kWh)	Estimated Annual Demand Savings (kW)	Incremental Cost
Low Flow Showerhead for Single Family Dwelling <sup>1</sup>	12	Standard showerhead flow	0.75		361	0.048	\$31.60
Low Flow Showerhead for Multifamily Dwelling <sup>2</sup>	12	Standard showerhead flow	0.5	43.7	203.7	0.0	\$31.60

[1] Taken from Morgan Measure Libraries

[2] Based on PY 2 EMV results.

### Low Flow Faucet Aerators

The energy savings equation for low flow faucet aerator was taken from Ameren Missouri's Multifamily PY2 Report.

## Appendix A – Technical Resource Manual

## Ameren Missouri

- The following table summarizes the measure level energy savings, demand savings, incremental cost, and effective useful life.
- Annual Operating Hours = 2361.75

Efficient Characteristics		Base Characteristics					
Description	Measure Life	Description	ΔGPM	ΔTemp (°F)	Estimated Annual Energy Savings (kWh)	Estimated Annual Demand Savings (kW)	Incremental Cost
Low Flow Faucet Aerator for Single Family Dwelling <sup>1</sup>	12	Standard faucet flow of 2.2 gpm	0.7	45	57	0.016	\$9.50
Low Flow Faucet Aerator for Multifamily Dwelling <sup>2</sup>	12	Standard showerhead flow of 2.2 gpm	0.7	18.7 <sup>3</sup>	37.2	0.0	\$9.50

[1] Taken from Morgan Measure Libraries

[2] Based on Ameren Missouri PY 2 EMV report.

[3] Assume faucet outlet temperature is 80°F according to 2009 Vermont TRM. Assume cold water inlet temperature for St. Louis, MO is 61.3°F according to <http://www.gfxtechnology.com/WaterTemp.pdf>

## Commercial and Industrial Energy Efficiency Measures

### Commercial Lighting

Interior Lighting Operating Hours by Building Type		
Building Type	Annual Hours	Building Mix Weighting**
Assembly	5,397	4.2%
Big Box Retail	6,439	4.0%
Fast Food Restaurant	6,492	2.4%
Full Service Restaurant	4,850	1.2%
Grocery	6,702	6.2%
Hospital	3,758	5.9%
Hotel	8,760*	1.7%
Large Office	5,571	11.3%
Light Industrial	5,594	43.0%
Primary School	3,149	7.2%
Small Office	4,342	5.6%
Small Retail	4,883	2.0%
Warehouse	5,063	5.3%
Weighted Average	5,202	100%



Source: From Ameren Missouri PY 2 EMV report conducted by ADM Associates, Inc. 2011  
 \*Non-Guest Room  
 \*\* Weights taken from Morgan Measure Database

### Commercial Lighting 3-Lamp T5 Fluorescent Lighting Fixture Replacing 250 watt HID

Current typical existing lighting market (baseline)	High Bay High Intensity Discharge (HID) – Metal Halide 250 W
Minimum threshold for credit	T5 High-output fluorescent lamps
Estimated savings credit for installing T5 High-Output <sup>1</sup>	449 kWh (per fixture)
Change in usage calculation <sup>2</sup>	$\Delta\text{kWh} = ((\text{WATTS}_{\text{base}} - \text{WATTS}_{\text{ee}}) * \text{HOURS} * \text{IF}) / 1000^*$
Estimated demand savings credit for installing T5 High-Output <sup>1</sup>	0.103 kW (per fixture)
Measure life	12 years
Incremental Cost <sup>1</sup>	\$ 180

[1] Taken from Morgan Measure Libraries

[2] Taken from Ohio TRM 2009

\*- If the appropriate field data required to complete this equation cannot be obtained, the deemed savings values in the table are to be used for each measure.

#### Key Assumptions:

- Coincidence Factor (CF) = 0.95
- IF = Interactive Factor = 1.0 (assumed to be 1 for the first 3 year implementation program until further data can be gathered and consensus can be built).
- $\text{WATTS}_{\text{base}}$  = Power draw (expressed in Watts) of base (existing) interior electrical equipment = 290 watts
- $\text{WATTS}_{\text{ee}}$  = Power draw (expressed in Watts) of efficient (replacement) electrical equipment = 182 watts
- HOURS = annual operating hours= 4,160 (lighting hour estimate taken from Morgan Measure Libraries)

### Commercial Lighting 4-Lamp T5 Fluorescent Lighting Fixture Replacing 400 watt Metal Halide

Current typical existing lighting market (baseline)	High Bay HID – Metal Halide 400 W
Minimum threshold for credit	T5 High-output fluorescent lamps
Estimated savings credit for installing T5 High-Output <sup>1</sup>	1180.8 kWh (per fixture)
Change in usage calculation <sup>2</sup>	$\Delta\text{kWh} = ((\text{WATTS}_{\text{base}} - \text{WATTS}_{\text{ee}}) * \text{HOURS} * \text{IF}) / 1000^*$
Estimated demand savings credit for installing T5 High-Output <sup>1</sup>	0.21 kW (per fixture)
Measure life	11 years
Incremental Cost <sup>1</sup>	\$ 339

[1] Taken from EMV PY 2 analysis

[2] Taken from Ohio TRM 2009

\*- If the appropriate field data required to complete this equation cannot be obtained, the deemed savings values in the table are to be used for each measure.

## Key Assumptions:

- Coincidence Factor (CF) = 0.95
- IF = Interactive Factor = 1.0 (assumed to be 1 for the first 3 year implementation program until further data can be gathered and consensus can be built).
- WATTS<sub>base</sub> = Power draw (expressed in Watts) of base (existing) interior electrical equipment = 470 watts
- WATTS<sub>ee</sub> = Power draw (expressed in Watts) of efficient (replacement) electrical equipment = 243 watts
- HOURS = annual operating hours= 5,202 (weighted average of all building stock)

**Commercial Lighting 6-Lamp T5 Fluorescent Lighting Fixture Replacing 400 watt Metal Halide**

Current typical existing lighting market (baseline)	High Bay HID – Metal Halide 400 W
Minimum threshold for credit	T5 High-output fluorescent lamps
Estimated savings credit for installing T5 High-Output <sup>1</sup>	1,015.4 kWh (per fixture)
Change in usage calculation <sup>2</sup>	$\Delta\text{kWh} = ((\text{WATTS}_{\text{base}} - \text{WATTS}_{\text{ee}}) * \text{HOURS} * \text{IF}) / 1000^*$
Estimated demand savings credit for installing T5 High-Output <sup>1</sup>	0.165 kW (per fixture)
Measure life <sup>1</sup>	11 years
Incremental Cost <sup>1</sup>	\$ 256

[1] Taken from EMV PY 2 analysis

[2] Taken from Ohio TRM 2009

\*- If the appropriate field data required to complete this equation cannot be obtained, the deemed savings values in the table are to be used for each measure.

## Key Assumptions:

- Coincidence Factor (CF) = 0.95
- IF = Interactive Factor = 1.0 (assumed to be 1 for the first 3 year implementation program until further data can be gathered and consensus can be built).
- WATTS<sub>base</sub> = Power draw (expressed in Watts) of base (existing) interior electrical equipment = 560 watts
- WATTS<sub>ee</sub> = Power draw (expressed in Watts) of efficient (replacement) electrical equipment = 365 watts
- HOURS = annual operating hours= 5,202 (weighted average of all building stock)

## Appendix A – Technical Resource Manual

## Ameren Missouri

**Commercial Lighting Double 6-Lamp T5 Fluorescent Lighting Fixture Replacing 1000 watt HID**

Current typical existing lighting market (baseline)	High Bay HID – Metal Halide 1,000 W
Minimum threshold for credit	T5 High-output fluorescent lamps
Estimated savings credit for installing T5 High-Output <sup>1</sup>	1,456 kWh (per fixture)
Change in usage calculation <sup>2</sup>	$\Delta\text{kWh} = ((\text{WATTS}_{\text{base}} - \text{WATTS}_{\text{ee}}) * \text{HOURS} * \text{IF}) / 1000^*$
Estimated demand savings credit for installing T5 High-Output <sup>1</sup>	0.333 kW (per fixture)
Measure life	12 years
Incremental Cost <sup>1</sup>	\$ 700

[1] Taken from Morgan Measure Libraries

[2] Taken from Ohio TRM 2009

\*- If the appropriate field data required to complete this equation cannot be obtained, the deemed savings values in the table are to be used for each measure.

## Key Assumptions:

- Coincidence Factor (CF) = 0.95
- IF = Interactive Factor = 1.0 (assumed to be 1 for the first 3 year implementation program until further data can be gathered and consensus can be built).
- $\text{WATTS}_{\text{base}}$  = Power draw (expressed in Watts) of base (existing) interior electrical equipment = 1,080 watts
- $\text{WATTS}_{\text{ee}}$  = Power draw (expressed in Watts) of efficient (replacement) electrical equipment = 730 watts
- HOURS = annual operating hours= 4,160 (lighting hour estimate taken from Morgan Measure Libraries)

**Commercial Lighting 4-Lamp T8 Fluorescent Lighting Fixture Replacing 250 watt HID**

Current typical existing lighting market (baseline)	High Bay HID – Metal Halide 250 W
Minimum threshold for credit	T8 Fluorescent
Estimated savings credit for installing T8 Fluorescent <sup>1</sup>	616 kWh (per fixture)
Change in usage calculation <sup>2</sup>	$\Delta\text{kWh} = ((\text{WATTS}_{\text{base}} - \text{WATTS}_{\text{ee}}) * \text{HOURS} * \text{IF}) / 1000^*$
Estimated demand savings credit for installing T8 Fluorescent <sup>1</sup>	0.141 kW (per fixture)
Measure life <sup>1</sup>	12 years
Incremental Cost <sup>1</sup>	\$ 160

[1] Taken from Morgan Measure Libraries

[2] Taken from Ohio TRM 2009

\*- If the appropriate field data required to complete this equation cannot be obtained, the deemed savings values in the table are to be used for each measure.

## Key Assumptions:

- Coincidence Factor (CF) = 0.95
- IF = Interactive Factor = 1.0 (assumed to be 1 for the first 3 year implementation program until further data can be gathered and consensus can be built).
- $WATTS_{base}$  = Power draw (expressed in Watts) of base (existing) interior electrical equipment = 290 watts
- $WATTS_{ee}$  = Power draw (expressed in Watts) of efficient (replacement) electrical equipment = 142 watts
- HOURS = annual operating hours= 4,160 (lighting hour estimate taken from Morgan Measure Libraries)

**Commercial Lighting 6-Lamp T8 Fluorescent Lighting Fixture Replacing 400 watt HID**

Current typical existing lighting market (baseline)	High Bay HID – Metal Halide 400 W
Minimum threshold for credit	T8 Fluorescent
Estimated savings credit for installing T8 Fluorescent <sup>1</sup>	961 kWh (per fixture)
Change in usage calculation <sup>2</sup>	$\Delta kWh = ((WATTS_{base} - WATTS_{ee}) * HOURS * IF) / 1000^*$
Estimated demand savings credit for installing T8 Fluorescent <sup>1</sup>	0.219 kW (per fixture)
Measure life <sup>1</sup>	12 years
Incremental Cost <sup>1</sup>	\$ 160

[1] Taken from Morgan Measure Libraries

[2] Taken from Ohio TRM 2009

\*- If the appropriate field data required to complete this equation cannot be obtained, the deemed savings values in the table are to be used for each measure.

## Key Assumptions:

- Coincidence Factor (CF) = 0.95
- IF = Interactive Factor = 1.0 (assumed to be 1 for the first 3 year implementation program until further data can be gathered and consensus can be built).
- $WATTS_{base}$  = Power draw (expressed in Watts) of base (existing) interior electrical equipment = 455watts
- $WATTS_{ee}$  = Power draw (expressed in Watts) of efficient (replacement) electrical equipment = 224 watts
- HOURS = annual operating hours= 4,160 (lighting hour estimate taken from Morgan Measure Libraries)

## Appendix A – Technical Resource Manual

## Ameren Missouri

**Commercial Lighting 8-Lamp T8 Fluorescent Lighting Fixture Replacing 400 watt HID**

Current typical existing lighting market (baseline)	High Bay HID – Metal Halide 400 W
Minimum threshold for credit	T8 Fluorescent
Estimated savings credit for installing T8 Fluorescent <sup>1</sup>	1,184 kWh (per fixture)
Change in usage calculation <sup>2</sup>	$\Delta\text{kWh} = ((\text{WATTS}_{\text{base}} - \text{WATTS}_{\text{ee}}) * \text{HOURS} * \text{IF}) / 1000^*$
Estimated demand savings credit for installing T8 Fluorescent <sup>1</sup>	0.22 kW (per fixture)
Measure life <sup>1</sup>	11 years
Incremental Cost <sup>1</sup>	\$ 414

[1] Based on Ameren Missouri PY 2 EMV analysis

[2] Taken from Ohio TRM 2009

\*- If the appropriate field data required to complete this equation cannot be obtained, the deemed savings values in the table are to be used for each measure.

## Key Assumptions:

- Coincidence Factor (CF) = 0.95
- IF = Interactive Factor = 1.0 (assumed to be 1 for the first 3 year implementation program until further data can be gathered and consensus can be built).
- $\text{WATTS}_{\text{base}}$  = Power draw (expressed in Watts) of base (existing) interior electrical equipment = 527 watts
- $\text{WATTS}_{\text{ee}}$  = Power draw (expressed in Watts) of efficient (replacement) electrical equipment = 299 watts
- HOURS = annual operating hours= 5,202 (weighted average of all building stock)

**Commercial Lighting Double 8-Lamp T8 Fluorescent Lighting Fixture Replacing 1,000 watt HID**

Current typical existing lighting market (baseline)	High Bay HID – Metal Halide 1,000 W
Minimum threshold for credit	T8 Fluorescent
Estimated savings credit for installing T8 Fluorescent <sup>1</sup>	2005 kWh (per fixture)
Change in usage calculation <sup>2</sup>	$\Delta\text{kWh} = ((\text{WATTS}_{\text{base}} - \text{WATTS}_{\text{ee}}) * \text{HOURS} * \text{IF}) / 1000^*$
Estimated demand savings credit for installing T8 Fluorescent <sup>1</sup>	0.458 kW (per fixture)
Measure life <sup>1</sup>	12 years
Incremental Cost <sup>1</sup>	\$ 400

[1] Taken from Morgan Measure Libraries

[2] Taken from Ohio TRM 2009

\*- If the appropriate field data required to complete this equation cannot be obtained, the deemed savings values in the table are to be used for each measure.

## Key Assumptions:

- Coincidence Factor (CF) = 0.95
- IF = Interactive Factor = 1.0 (assumed to be 1 for the first 3 year implementation program until further data can be gathered and consensus can be built).
- $WATTS_{base}$  = Power draw (expressed in Watts) of base (existing) interior electrical equipment = 1,080 watts
- $WATTS_{ee}$  = Power draw (expressed in Watts) of efficient (replacement) electrical equipment = 598 watts
- HOURS = annual operating hours= 4,160 (lighting hour estimate taken from Morgan Measure Libraries)

**Commercial LED Exit Signs Replacing Incandescent Exit Sign**

Current typical existing lighting market (baseline)	Incandescent Exit Sign
Minimum threshold for credit	LED Exit Sign
Estimated savings credit for installing T5 High-Output <sup>1</sup>	237 kWh (per fixture)
Change in usage calculation <sup>2</sup>	$\Delta kWh = ((WATTS_{base} - WATTS_{ee}) * HOURS * IF) / 1000^*$
Estimated demand savings credit for installing T5 High-Output <sup>1</sup>	0.032kW (per fixture)
Measure life <sup>1</sup>	16 years
Incremental Cost <sup>1</sup>	\$ 63

[1] Based on Ameren Missouri PY 2 EMV report

[2] Taken from Ohio TRM 2009

\*- If the appropriate field data required to complete this equation cannot be obtained, the deemed savings values in the table are to be used for each measure.

## Key Assumptions:

- Coincidence Factor (CF) = 1.0
- IF = Interactive Factor = 1.0 (assumed to be 1 for the first 3 year implementation program until further data can be gathered and consensus can be built).
- $WATTS_{base}$  = Power draw (expressed in Watts) of base (existing) interior electrical equipment = 30 watts
- $WATTS_{ee}$  = Power draw (expressed in Watts) of efficient (replacement) electrical equipment = 3 watts
- HOURS = annual operating hours= 8,760

## Appendix A – Technical Resource Manual

## Ameren Missouri

**Commercial Pulse Start Metal Halide**

Current typical existing lighting market (baseline)	High Intensity Discharge Lamp
Minimum threshold for credit	Pulse Start Metal Halide
Estimated savings credit Pulse-start MH 150 – 200 W <sup>1</sup>	237 kWh
Estimated savings credit Pulse-start MH 320 W <sup>1</sup>	354 kWh
Estimated savings credit Pulse-start MH 750 W <sup>1</sup>	1,090 kWh
Change in usage calculation <sup>2</sup>	$\Delta\text{kWh} = ((\text{WATTS}_{\text{base}} - \text{WATTS}_{\text{ee}}) * \text{HOURS} * \text{IF}) / 1000^*$
Estimated demand savings credit Pulse-start MH 150 – 200 W <sup>1</sup>	0.054 kW
Estimated demand savings credit Pulse-start MH 320 W <sup>1</sup>	0.081 kW
Estimated demand savings credit Pulse-start MH 750 W <sup>1</sup>	0.249 kW
Measure life <sup>1</sup>	16 years
Incremental Cost Pulse-start MH 150 – 200 W <sup>1</sup>	\$ 135
Incremental Cost Pulse-start MH 320 W <sup>1</sup>	\$ 150
Incremental Cost Pulse-start MH 750 W <sup>1</sup>	\$ 200

[1] Taken from Morgan Measure Libraries

[2] Taken from Ohio TRM 2009

\*- If the appropriate field data required to complete this equation cannot be obtained, the deemed savings values in the table are to be used for each measure.

## Key Assumptions:

- Coincidence Factor (CF) = 0.95
- IF = Interactive Factor = 1.0 (assumed to be 1 for the first 3 year implementation program until further data can be gathered and consensus can be built).
- $\text{WATTS}_{\text{base}}$  = Power draw (expressed in Watts) of base (existing) interior electrical equipment = See table below.
- $\text{WATTS}_{\text{ee}}$  = Power draw (expressed in Watts) of efficient (replacement) electrical equipment = See table below.
- HOURS = annual operating hours= 4,160 (lighting hour estimate taken from Morgan Measure Libraries)

Efficient Measure	Baseline Measure	Wattseffic	Wattsbase
Average 150, 175, 200	Avg 175 and 250	210	267
320 Watt Metal Halide- Pulse Start	400 W HID	370	455
750 Watt Metal Halide - Pulse Start	1000 W HID	818	1080

## Appendix A – Technical Resource Manual

## Ameren Missouri

### Commercial Ceramic Metal Halide (20 – 100 watt)

Current typical existing lighting market (baseline)	Incandescent Display Lighting
Minimum threshold for credit	Ceramic Metal Halide
Estimated savings credit Pulse-start MH 150 – 200 W <sup>1</sup>	445 kWh
Change in usage calculation <sup>2</sup>	$\Delta\text{kWh} = ((\text{WATTS}_{\text{base}} - \text{WATTS}_{\text{ee}}) * \text{HOURS} * \text{IF}) / 1000^*$
Estimated demand savings credit Pulse-start MH 150 – 200 W <sup>1</sup>	0.115 kW
Measure life <sup>1</sup>	16 years
Incremental Cost Pulse-start MH 150 – 200 W <sup>1</sup>	\$ 225

[1] Taken from Morgan Measure Libraries

[2] Taken from Ohio TRM 2009

\*- If the appropriate field data required to complete this equation cannot be obtained, the deemed savings values in the table are to be used for each measure.

#### Key Assumptions:

- Coincidence Factor (CF) = 0.95
- IF = Interactive Factor = 1.0 (assumed to be 1 for the first 3 year implementation program until further data can be gathered and consensus can be built).
- $\text{WATTS}_{\text{base}}$  = Power draw (expressed in Watts) of base (existing) interior electrical equipment = 185 watts
- $\text{WATTS}_{\text{ee}}$  = Power draw (expressed in Watts) of efficient (replacement) electrical equipment = 64 watts
- HOURS = annual operating hours= 3,680 (lighting hour estimate taken from Morgan Measure Libraries)

### Commercial LED/Induction Garage Light Replacing HID Exterior Light

Current typical existing lighting market (baseline)	High Intensity Discharge Lamp
Minimum threshold for credit	LED/Induction
Estimated savings credit Pulse-start MH 175 – 250 W <sup>1</sup>	936 kWh
Estimated savings credit Pulse-start MH 400 W <sup>1</sup>	1,614 kWh
Change in usage calculation <sup>2</sup>	$\Delta\text{kWh} = ((\text{WATTS}_{\text{base}} - \text{WATTS}_{\text{ee}}) * \text{HOURS} * \text{IF}) / 1000^*$
Estimated demand savings credit Pulse-start MH 175 – 250 W <sup>1</sup>	0.102 kW
Estimated demand savings credit Pulse-start MH 400 W <sup>1</sup>	0.175 kW
Measure life <sup>1</sup>	12 years
Incremental Cost Ceramic MH 175 – 200 W <sup>1</sup>	\$ 500
Incremental Cost Ceramic MH 400 W <sup>1</sup>	\$ 800

[1] Taken from Morgan Measure Libraries

[2] Taken from Ohio TRM 2009



## Appendix A – Technical Resource Manual

## Ameren Missouri

\*- If the appropriate field data required to complete this equation cannot be obtained, the deemed savings values in the table are to be used for each measure.

### Key Assumptions:

- Coincidence Factor (CF) = 0.95
- IF = Interactive Factor = 1.0 (assumed to be 1 for the first 3 year implementation program until further data can be gathered and consensus can be built).
- $WATTS_{base}$  MH 400 watt = Power draw (expressed in Watts) of base (existing) interior electrical equipment = 461 watts
- $WATTS_{ee}$  MH 400 watt = Power draw (expressed in Watts) of efficient (replacement) electrical equipment = 279 watts
- $WATTS_{base}$  MH 175 – 250 watt = Power draw (expressed in Watts) of base (existing) interior electrical equipment = 267 watts
- $WATTS_{ee}$  MH 175 – 250 watt = Power draw (expressed in Watts) of efficient (replacement) electrical equipment = 160 watts
- HOURS = annual operating hours= 8,760

### Commercial Compact Fluorescent Lights/LED Replacing Incandescent Bulb

Current typical existing lighting market (baseline)	Incandescent (or EISA compliant equivalent)
Minimum threshold for credit	Compact Fluorescent Lights
Estimated savings CFL	See table below
Change in usage calculation <sup>2</sup>	$\Delta kWh = ((WATTS_{base} - WATTS_{ee}) * HOURS * IF) / 1000^*$
Estimated demand savings credit CFL	See table below
Measure life	See table below
Incremental Cost CFL	See table below

[1] Taken from Morgan Measure Libraries

[2] Taken from Ohio TRM 2009

\*- If the appropriate field data required to complete this equation cannot be obtained, the deemed savings values in the table are to be used for each measure.

### Key Assumptions:

- Coincidence Factor (CF) = 0.95
- IF = Interactive Factor = 1.0 (assumed to be 1 for the first 3 year implementation program until further data can be gathered and consensus can be built).
- $WATTS_{base}$  = Power draw (expressed in Watts) of base (existing) interior electrical equipment = See table below.
- $WATTS_{ee}$  = Power draw (expressed in Watts) of efficient (replacement) electrical equipment = See table below.
- HOURS = annual operating hours= 3,680 (lighting hour estimate taken from Morgan Measure Libraries)

## Appendix A – Technical Resource Manual

## Ameren Missouri

Efficient Measure	Baseline Measure	Watts effic	Watts base	kWh Saving s	Coincid ent kW Savings	Incr. Cost	Mea sure Life
Compact fluorescent lamp less than 30W <sup>1</sup>	Incandescent lamp	19	74	202	0.05	\$3	2
Compact fluorescent lamp ≤ 30W X ≤ 115W <sup>1</sup>	Incandescent lamp	65	200	497	0.12	\$15	2
Compact fluorescent lamps with reflectors <sup>1</sup>	Incandescent lamps with reflectors	19	74	202	0.05	\$6	2
GU-24 pin-based CFL <sup>2</sup>	Incandescent ≤ 100W	21	100	411	0.04	\$11	12
Interior CF 1L 26W Quad <sup>2</sup>	Incandescent	26	169	745	0.14	\$92	11
Interior CF 1L 32W Triple <sup>2</sup>	Incandescent	32	65	172	0.03	\$135	11
New pin-based CFL Fixture (>45W) <sup>2</sup>	Incandescent >100W	45	224	1,402	0.14	\$327	11
LED lamp <sup>1</sup>	Incandescent lamp	12	60	177	0.04	\$ 70	15

[1] Taken from Morgan Measure Libraries: assumes 3,680 hours

[2] Based on Ameren Missouri PY 2 EMV report from ADM: assumes 5,202 hours

### Commercial LED Case Lighting

Current typical existing lighting market (baseline)	T8 Fluorescent
Minimum threshold for credit	LED replacement
Estimated savings <sup>1</sup>	429 kWh per door
Change in usage calculation <sup>2</sup>	$\Delta\text{kWh} = ((\text{WATTS}_{\text{base}} - \text{WATTS}_{\text{ee}}) * \text{HOURS} * \text{IF}) / 1000^*$
Estimated demand savings credit <sup>1</sup>	0.041 kW per door
Measure life <sup>1</sup>	15 years
Incremental Cost <sup>1</sup>	\$ 300

[1] Taken from Morgan Measure Libraries

[2] Taken from Ohio TRM 2009

\*- If the appropriate field data required to complete this equation cannot be obtained, the deemed savings values in the table are to be used for each measure.

#### Key Assumptions:

- 25% of heat is lost through the case
- IF = Interactive Factor = 1.0
- Coincidence Factor (CF) = 0.95
- IF = Interactive Factor = 1.0 (assumed to be 1 for the first 3 year implementation program until further data can be gathered and consensus can be built).
- $\text{WATTS}_{\text{base}}$  = Power draw (expressed in Watts) of base (existing) interior electrical equipment = T8 Lighting (74 watts) + refrigeration load (25 watts) = 99 watts
- $\text{WATTS}_{\text{ee}}$  = Power draw (expressed in Watts) of efficient (replacement) electrical equipment = LED (37 watts) + refrigeration load (13 watts) = 50 watts

## Appendix A – Technical Resource Manual

## Ameren Missouri

- HOURS = annual operating hours= 8,760

### Lighting Controls

Current typical existing lighting market (baseline)	No Controls
Minimum threshold for credit	Automated or motion controls
Estimated kWh savings <sup>1</sup>	See table below
Change in usage calculation <sup>2</sup>	
Estimated demand savings <sup>1</sup>	See table below
Measure life <sup>1</sup>	10 years
Incremental Cost <sup>1</sup>	See table below

[1] Taken from Morgan Measure Libraries

[2] Taken from Ohio TRM 2009

\*- If the appropriate field data required to complete this equation cannot be obtained, the deemed savings values in the table are to be used for each measure.

#### Key Assumptions:

- 3,680 hours of operation (lighting hour estimate taken from Morgan Measure Libraries)
- SF = square feet of controlled lighting space
- Watt/SF = watt per square feet of controlled lighting space
- Coincidence Factor (CF) = 0.90 (Daylight Sensor Controls have CF = 0.95)
- DF = Diversity Factor (assumed at 0.9)

Measure	Square Feet	% Reduction	Watt/SF	kWh	Coincident kW	Incremental Cost	Measure Life
Occupancy Sensors under 500 W <sup>1</sup>	300	30%	1.20	397	0.099	\$144	10
Occupancy Sensors over 500 W <sup>1</sup>	750	30%	1.20	994	0.243	\$311	10
Central Lighting Control <sup>1</sup>	10,000	25%	1.25	11500	2.808	\$3,700	12
Switching Controls for Multilevel Lighting <sup>1</sup>	10,000	18%	1.25	8000	2.196	\$4,000	12
Daylight Sensor controls <sup>1</sup>	10,000	30%	1.30	14800	3.819	\$4,000	12
Passive Infrared or Ultrasonic <sup>2</sup>				616.3	0.023	\$92	11
Dual Technology Sensors <sup>2</sup>				770.4	0.034	\$128	8
Interior Wall Sensors (3 2-lamp T8 fixtures) <sup>2</sup>				620.9	0.060	\$91	11

[1] Taken from Morgan Measure Libraries

[2] Based on Ameren Missouri PY 2 EMV report

**Retro-commissioning Lighting**

Current typical existing market (baseline)	Conventional Lighting Set-up at existing facility
Minimum threshold for credit	5% Improvement in building's lighting load
Estimated savings for 5 degree reset <sup>1</sup>	5,311.4 kWh
Estimated savings for 10 degree reset <sup>1</sup>	0.939 kW
Measure life <sup>1</sup>	5 years
Incremental Cost <sup>1</sup>	\$ 761 per project

[1] Taken from Morgan Measure Libraries (GEP Potential Study Measure list)

## Key Assumptions:

- Assumes 6% savings of building's lighting energy consumption

**Commercial Cooking Equipment****Energy Star Steam Cookers**

Current typical existing cooking market (baseline)	Electric Steam Cooker (26% efficient)
Minimum threshold for credit	Energy Star Steam Cooker (50% efficient)
Estimated savings credit 3 pan <sup>1</sup>	11,188 kWh
Estimated savings credit 4 pan <sup>1</sup>	12,159 kWh
Estimated savings credit 5 pan <sup>1</sup>	13,139 kWh
Estimated savings credit 6 pan <sup>1</sup>	15,170 kWh
Change in usage calculation <sup>1</sup>	$\Delta kWh = LB_{Food} * \frac{E_{Food}}{\Delta Efficiency} + (1 - PTMM) * \Delta IdleRate * (OpHrs - \frac{LB_{Food}}{\Delta PC} - \frac{T_{preHT}}{60}) + E_{preHT} * Days$
Estimated demand	2.55 kW/unit

savings credit 3 pan <sup>1</sup>	
Estimated demand savings credit 4 pan <sup>1</sup>	2.85 kW/unit
Estimated demand savings credit 5 pan <sup>1</sup>	3.16 kW/unit
Estimated demand savings credit 6 pan <sup>1</sup>	3.46 kW/unit
Measure life <sup>1</sup>	12 years
Incremental Cost <sup>1</sup>	\$4,150

[1] Taken from Morgan Measure Libraries

[2] Taken from Ohio TRM 2009

\*- If the appropriate field data required to complete this equation cannot be obtained, the deemed savings values in the table are to be used for each measure.

#### Key Assumptions:

- One pre-heat daily, the preheat time is assumed to be 15 minutes, and the preheat energy 1.5 kWh/day.
- The amount of food cooked per day in each size of cooker is assumed to be:
  - 3 pan - 100 lbs
  - 4 pan - 128 lbs
  - 5 pan - 160 lbs
  - 6 pan - 192 lbs
- The ASTM Energy to Food value used is 0.0308 kWh/lb.
- PTMM = average amount of time per day steamer is operated in manual (constant steam) mode. Expressed as percentage per day.
- Days = days per year = 365
- CF = Coincidence Factor = 1.0

E<sub>Day</sub> = Daily Energy Consumption (kWh/day) or (BTU/day)

L<sub>B</sub>Food = Pounds of Food Cooked per Day (lb/day)

E<sub>food</sub> = ASTM Energy to Food (kWh/lb) = kWh/pound of energy absorbed by food product during cooking or (BTU/lb)

Efficiency = Heavy Load Cooking Energy Efficiency %

IdleRate = Idle Energy Rate (kW) or (BTU/hr)

OpHrs = Operating Hours/Day (hr/day) = 12

PC = Production Capacity (lbs/hr)

TPreHt = Preheat Time (min/day)  
EPreHt = Preheat Energy (kWh/day) or (BTU/day)  
ResidualRate = Residual Energy Rate (kW)

**Energy Hot Food Holding Cabinets (full size)**

Current typical existing cooking market (baseline)	Electric Hot Food Holding Cabinets (70 W/ft <sup>3</sup> )
Minimum threshold for credit	Energy Star Hot Food Holding Cabinet (< 40 W/ft <sup>3</sup> internal volume)
Estimated savings credit full size <sup>1</sup>	5,278 kWh
Estimated savings credit three- quarter size <sup>1</sup>	2,832 kWh
Estimated savings credit half size <sup>1</sup>	1,788 kWh
Change in usage calculation <sup>1</sup>	$\Delta kWh = \frac{\text{InternalVolume} * (\Delta\text{Watts} / \text{Volume}) * (\text{Hours} / \text{Year})}{1000} *$
Estimated demand savings credit full size <sup>1</sup>	0.96 kW/unit
Estimated demand savings credit three- quarter size <sup>1</sup>	0.52 kW/unit
Estimated demand savings credit half size <sup>1</sup>	0.33 kW/unit
Measure life <sup>1</sup>	12 years
Incremental Cost <sup>1</sup>	\$1,783

[1] Taken from Morgan Measure Libraries

\*- If the appropriate field data required to complete this equation cannot be obtained, the deemed savings values in the table are to be used for each measure.

## Key Assumptions:

- The demand is assumed to be the average demand (per Food Service Technology Center).
- Hot Food Holding Cabinets operate 15 hours per day (same assumption as used by the Food Service Technology Center and the ENERGY STAR savings calculator).
- The volume of each size range for calculation purposes (as also used in the ENERGY STAR calculator and the Food Service Technology Center workpapers) are:
  - Full Size - >15 ft<sup>3</sup> (average volume used is 20 ft<sup>3</sup>)
  - Three-quarter Size – 10-15 ft<sup>3</sup> (average volume used is 12 ft<sup>3</sup>)
  - Half Size - <10 ft<sup>3</sup> (average volume used is 8 ft<sup>3</sup>)
- Coincidence Factor = CF = 1.0

## Commercial Refrigeration

### Energy Star Commercial Refrigerators and Freezers

Current typical existing market (baseline)	Type	kWh Base
	Solid Door Refrigerators <sup>1</sup>	$0.1 * \text{Volume} + 2.04$
	Glass Door Refrigerators <sup>1</sup>	$0.12 * \text{Volume} + 3.34$
	Solid Door Freezers <sup>1</sup>	$0.4 * \text{Volume} + 1.38$
	Glass Door Freezers <sup>1</sup>	$0.75 * \text{Volume} + 4.11$
Minimum threshold for credit	See table below	
Estimated savings <sup>1</sup>	See Table Below	
Measure life <sup>1</sup>	12 years	
Incremental Cost <sup>1</sup>	See table below	

[1] Taken from Morgan Measure Libraries

#### Key Assumptions:

- 8760 operating hours per year
- CF (coincident peak factor)

Product Volume (in cubic feet)	Refrigerator	Freezer
<i>Solid Door Cabinets</i>		
$0 < V < 15$	$\leq 0.089V + 1.411$	$\leq 0.250V + 1.250$
$15 \leq V < 30$	$\leq 0.037V + 2.200$	$\leq 0.400V - 1.000$
$30 \leq V < 50$	$\leq 0.056V + 1.635$	$\leq 0.163V + 6.125$
$50 \leq V$	$\leq 0.060V + 1.416$	$\leq 0.158V + 6.333$
<i>Glass Door Cabinets</i>		
$0 < V < 15$	$\leq 0.118V + 1.382$	$\leq 0.607V + 0.893$
$15 \leq V < 30$	$\leq 0.140V + 1.050$	$\leq 0.733V - 1.000$
$30 \leq V < 50$	$\leq 0.088V + 2.625$	$\leq 0.250V + 13.500$
$50 \leq V$	$\leq 0.110V + 1.500$	$\leq 0.450V + 3.500$

[1] Morgan Measure Libraries



## Appendix A – Technical Resource Manual

## Ameren Missouri

*Efficient Refrigerators and Freezers Savings and Costs*

Measure	kWh Savings	kW Savings	Incremental Cost
ENERGY STAR Commercial Solid Door Freezers less than 15ft <sup>3</sup>	595.0	0.068	\$ 150
ENERGY STAR Commercial Solid Door Freezers 15 to 30 ft <sup>3</sup>	869.0	0.099	\$ 400
ENERGY STAR Commercial Solid Door Freezers 30 to 50ft <sup>3</sup>	1,728.0	0.197	\$ 550
ENERGY STAR Commercial Solid Door Freezers more than 50ft <sup>3</sup>	3,757.0	0.429	\$ 700
ENERGY STAR Commercial Glass Door Refrigerators less than 15ft <sup>3</sup>	722.0	0.082	\$ 250
ENERGY STAR Commercial Glass Door Refrigerators 15 to 30 ft <sup>3</sup>	1,434.0	0.164	\$ 500
ENERGY STAR Commercial Glass Door Freezers less than 15ft <sup>3</sup>	1,693.0	0.193	\$ 220
ENERGY STAR Commercial Glass Door Freezers 15 to 30 ft <sup>3</sup>	2,004.0	0.229	\$ 950
ENERGY STAR Commercial Glass Door Freezers 30 to 50ft <sup>3</sup>	3,869.0	0.442	\$ 1,307
ENERGY STAR Commercial Glass Door Freezers more than 50ft <sup>3</sup>	7,118.0	0.813	\$ 2,300

**Energy Star Ice Machines**

Current typical existing market (baseline)	N/A
Minimum threshold for credit	Energy Star Certified Ice Machines
Estimated savings < 500 lbs/24 hours <sup>1</sup>	1,652 kWh/unit
Estimated savings 500 – 1000 lbs/24 hours <sup>1</sup>	2,695 kWh/unit
Estimated savings >1000 lbs/24 hours <sup>1</sup>	6,048 kWh/unit
Change in usage calculation <sup>1</sup>	
Estimated demand savings < 500 lbs/24 hours <sup>1</sup>	0.1886 kW/unit
Estimated demand savings 500 – 1000 lbs/24 hours <sup>1</sup>	0.3077 kW/unit
Estimated demand savings >1000 lbs/24 hours <sup>1</sup>	0.6904 kW/unit
Measure life <sup>1</sup>	12 years
Incremental Cost < 500 lbs/24 hours <sup>1</sup>	\$600
Incremental Cost 500 – 1000 lbs/24 hours <sup>1</sup>	\$1,500
Incremental Cost >1000 lbs/24 hours <sup>1</sup>	\$2,000

[1] Taken from Morgan Measure Libraries

\*- If the appropriate field data required to complete this equation cannot be obtained, the deemed savings values in the table are to be used for each measure.

## Key Assumptions:

- Load Factor = LF =75% = pounds of ice used per day or Ice Harvest rate
- Ice Harvest Rate = lbs/24 hours
- 8760 operating hours per year
- Coincidence Factor = CF = 1.0

**Anti-Sweat Heater Controls**

Current typical existing market (baseline)	Door with no control
Minimum threshold for credit	Automated Control
Estimated savings <sup>1</sup>	1,367 kWh per unit
Change in usage calculation <sup>2</sup>	$\Delta kWh = kW_{base} * NUM_{doors} * ESF * BF *$
Estimated demand savings <sup>1</sup>	0.079 kW per unit
Measure life <sup>1</sup>	12 years
Incremental Cost <sup>1</sup>	\$ 151

[1] Based on Ameren Missouri PY 2 EMV report

[2] Taken from Ohio TRM 2009

\*- If the appropriate field data required to complete this equation cannot be obtained, the deemed savings values in the table are to be used for each measure.

## Key Assumptions:

- NUMdoors = number of doors
- ESF = Energy Savings Factor; percentage of annual hours door heater is powered off due to control (assume 60%)
- BF = Bonus Factor = increased savings due to reduction in cooling load inside cases. Assume 1.15.
- kWbase = connected load kW for typical reach-in refrigerator or freezer door and frame with a heater.

**Strip Curtains for Walk-in Coolers**

Current typical existing market (baseline)	No curtains
Minimum threshold for credit	Strip curtains installed
Estimated savings <sup>1</sup>	5058 kWh per unit
Estimated demand savings credit <sup>1</sup>	0.628 kW per unit
Measure life <sup>1</sup>	4 years
Incremental Cost <sup>1</sup>	\$ 132

[1] Based on Ameren Missouri PY 2 EMV report

**Beverage Vending Machine Controls**

Current typical existing market (baseline)	Beverage Vending Machine with no controls
Minimum threshold for credit	Beverage vending machine automated/motion controls
Estimated savings <sup>1</sup>	1,646 kWh per unit
Change in usage calculation <sup>2</sup>	$\Delta kWh = 8760 * WATT_{Sbase} / 1000 * ESF *$
Estimated demand savings credit <sup>1</sup>	0.055 kW per unit
Measure life <sup>1</sup>	5 years
Incremental Cost <sup>1</sup>	\$ 141

[1] Based on Ameren Missouri PY 2 EMV report

[2] Taken from Ohio TRM 2009

\*- If the appropriate field data required to complete this equation cannot be obtained, the deemed savings values in the table are to be used for each measure.

Key Assumptions:

- ESF = Energy Savings Factor = 35% (per Morgan Measure Library)
- WATTSbase = 536.85 watts per unit

Alternatively, if the variables listed in the above equation are not available, the following equation and parameters can be used to estimate savings:

**Efficient Refrigeration Condenser**

Current typical existing market (baseline) <sup>1</sup>	Medium Temperature System = 15°F design approach Low Temperature System = 10°F design approach
Minimum threshold for credit <sup>1</sup>	Condenser design temperature approach must be at or below the following parameters: Air-cooled condensers (exiting refrigerant vs. ambient dry bulb temperature): low temperature systems (8°F) and medium temperature systems (13°F). Evaporative-cooled condensers (exiting refrigerant vs. ambient wet bulb temperature): 18°F.
Change in use Calculation <sup>1</sup>	
Estimated savings <sup>1</sup>	120 kWh per ton
Estimated demand savings credit <sup>1</sup>	0.118 kW per ton
Measure life <sup>1</sup>	15 years
Incremental Cost <sup>1</sup>	\$ 35 per ton

[1] Taken from Morgan Measure Libraries

\*- If the appropriate field data required to complete this equation cannot be obtained, the deemed savings values in the table are to be used for each measure.

Key Assumptions:

- FLH = Full Load Hours = 4,380 hours
- System Capacity = Full Load = 2.3 kW/ton at 105°F saturated condensing temp.
- Average Annual Load
- Baseline (10°F condenser approach) operating based on 82F ambient had an average. load of 81.6%; based on 70F ambient had an average. load of 78.9%
- Efficient (7°F condenser approach) operating based on 82F ambient had an average. load of 83.2%; based on 70F ambient had an average. load of 80%
- FLE = Full Load Efficiency
  - Baseline based on 82F 1.92 kW/ton; based on 70F 1.85 kW/ton
  - Efficient based on 82F 1.86 kW/ton; based on 70F 1.78 kW/ton

**Night Covers**

Current typical existing market (baseline) <sup>1</sup>	No Covers
Minimum threshold for credit <sup>1</sup>	Night covers installed
Estimated savings credit <sup>1</sup>	43.8 kWh per linear foot
Estimated demand savings credit <sup>1</sup>	0.00 kW per linear foot
Measure life <sup>1</sup>	10 years
Incremental Cost <sup>1</sup>	\$ 15 per linear foot

[1] Numbers derived from 2011 Massachusetts Technical Reference Manual.

$$\Delta kWh = (Width)(Save)(Hours)$$

$$\Delta kW = (Width)(Save)$$

- Width = Width of the opening that the night covers protect (ft)

- Save = Savings factor based on the temperature of the cooler case (kW/ft)
- Hours = Annual hours that the night covers are in use

#### Cooler Case Temperature Savings Factor

- Low Temperature (-35 F to -5 F) 0.03 kW/ft
- Medium Temperature (0 F to 30 F) 0.02 kW/ft
- High Temperature (35 F to 55 F) 0.01 kW/ft

#### Key Assumptions:

1. Applicant must install a night cover on an open refrigerated case at close of business each day. The savings estimate for this measure assumes that a night cover is placed on an open case that was previously left uncovered.
2. Hours of operation = for a minimum of 6 hours per day, assumed 2,190 hours per year

#### ECM for Refrigeration

Current typical existing market (baseline) <sup>1</sup>	Shaded Pole or PSC on existing case
Minimum threshold for credit <sup>1</sup>	ECM installed
Estimated savings credit <sup>1</sup>	544 kWh
Estimated demand savings credit <sup>1</sup>	0.062 kW
Measure life <sup>1</sup>	15 years
Incremental Cost <sup>1</sup>	\$ 114

[1] Numbers derived from DEER 2005.

#### Key Assumptions:

1. ECM savings are based on an average of typical sizes of ECM's over PSC motors, as well as ECM's over shaded-pole motors for all types of refrigeration cases, (i.e. large walk-ins, small frozen, coffin style, etc.)
2. User surveys from retailers were conducted to determine the single weighted-average of savings values among types of refrigeration cases.
3. Minimum qualifying ECM size is 1/20 hp.

The following algorithms specify how Gross energy savings and demand reduction for motor upgrades are calculated<sup>6</sup>:

$$\Delta\text{kWhFAN} = \text{RHP} \times 0.746 \times \text{LF} \times (1/\text{ME-base} - 1/\text{ME-eff.}) \times \text{EFLH}$$

$$\Delta\text{kWhHEAT} = \Delta\text{kWhFAN} \times 0.28 \times \text{EFF}_{\text{RS}}$$

$$\Delta\text{kW} = \text{RHP} \times 0.746 \times \text{LF} \times (1/\text{MF-base} - 1/\text{MF-eff.}) \times \text{CF}$$

Where:

$\Delta\text{kWhFAN}$  = Energy savings due to increased motor efficiency

$\Delta\text{kWhHEAT}$  = Energy savings due to reduced heat from evaporator fans

RHP = Horsepower rating of motor (hp) as shown on nameplate

0.746 = Conversion Factor (0.746 kW/hp)

<sup>6</sup>Lockheed Martin, Cycle 1 Ameren Missouri TRM calculations 2009 – 2011. Massachusetts TRM 2011.

LF	=	Load Factor of motor (ratio of maximum operating hp load to nameplate hp)
ME-base	=	Efficiency of base (existing) motor
ME-eff.	=	Efficiency of replacement (efficient) motor
UF	=	Utilization Factor of motor (ratio of average annual hp load to maximum operating hp load)
AOH	=	Annual operating hours of motor
EFLH	=	Equivalent Full-Load Hours = AOH x UF
CF	=	Coincidence Factor (percentage of a motor's maximum power draw during Ameren's peak system demand period)
EFF <sub>RS</sub>	=	Efficiency of typical refrigeration system – 1.6 kW/ton. (60%)

### Auto door closers

Current typical existing market (baseline) <sup>1</sup>	Low or Medium Temperature walk in or reach in (-10 to 41F)
Minimum threshold for credit <sup>1</sup>	Auto Door closer installed
Estimated savings credit <sup>1</sup>	681 kWh
Estimated demand savings credit <sup>1</sup>	0.223 kW
Measure life <sup>1</sup>	8 years
Incremental Cost <sup>2</sup>	\$ 157

[1] Numbers derived from DEER 2005.

[2] Costs taken from Illinois TRM 2012.

#### Key Assumptions:

- Measures consist of installing an automatic door closer on an existing walk-in cooler or freezer door.
- Using the door open time estimate, energy savings captured by the automatic door closer is calculated to be approximately 12% of cooling load for each case type.
- Auto door closers should be applied to the main insulated door of a walk-in or reach-in cooler or freezer.
- For both walk-in and reach-in cases, the minimum door perimeter is 16 feet.
- One closer per case door.

## Commercial Hot Water Measures

### Commercial Heat Pump Hot Water Heaters

Current typical existing market (baseline)	98%
Minimum threshold for credit	≥ 3.0 COP
Estimated savings 10,000 – 50,000 BTU/h <sup>1</sup>	21,156 kWh/unit
Estimated savings 50,000 – 100,000 BTU/h <sup>1</sup>	52,890 kWh/unit
Estimated savings 100,000 – 300,000 BTU/h <sup>1</sup>	141,041 kWh/unit

## Appendix A – Technical Resource Manual

## Ameren Missouri

Estimated savings 300,000 – 500,000 BTU/h <sup>1</sup>	282,081 kWh/unit
Estimated savings > 500,000 BTU/h <sup>1</sup>	423,122 kWh/unit
Change in usage calculation <sup>2</sup>	
Estimated savings 10,000 – 50,000 BTU/h <sup>1</sup>	4.2 kW/unit
Estimated demand savings 50,000 – 100,000 BTU/h <sup>1</sup>	10.5 kW/unit
Estimated demand savings 100,000 – 300,000 BTU/h <sup>1</sup>	28 kW/unit
Estimated demand savings 300,000 – 500,000 BTU/h <sup>1</sup>	56 kW/unit
Estimated demand savings > 500,000 BTU/h <sup>1</sup>	84 kW/unit
Measure life <sup>1</sup>	15 years
Incremental Cost 10,000 – 50,000 BTU/h <sup>1</sup>	\$6,000
Incremental Cost 50,000 – 100,000 BTU/h <sup>1</sup>	\$14,000
Incremental Cost 100,000 – 300,000 BTU/h <sup>1</sup>	\$25,000
Incremental Cost 300,000 – 500,000 BTU/h <sup>1</sup>	\$42,000
Incremental Cost > 500,000 BTU/h <sup>1</sup>	\$63,000

[1] Taken from Morgan Measure Libraries

[2] Taken from Ohio TRM 2009, addition of DF from Morgan Measure Libraries

\*- If the appropriate field data required to complete this equation cannot be obtained, the deemed savings values in the table are to be used for each measure.

### Key Assumptions:

- E<sub>t</sub> Base: Thermal efficiency of a standard commercial electric water heater: 98%
- COP of an ASHP water heater: 3.5
- Cost estimates include installation.
- 77°F temperature difference from makeup water to hot water supply (Standard US DOE Test Procedure)
- Diversity Factor (DF): 0.65 = impact on demand of diversity between multiple water heating units in building.
- Heaters are generally located in unconditioned spaces
- 360 days per year
- E<sub>t</sub> Base: Thermal efficiency of existing unit

### Pre-Rinse Spray Valves

Current typical existing market (baseline)	≥1.6 gpm
Minimum threshold for credit	≤ 0.64 gpm
Estimated savings <sup>1</sup>	5,626 kWh



## Appendix A – Technical Resource Manual

## Ameren Missouri

Change in usage calculation <sup>1</sup>	*
Estimated demand savings credit full size <sup>1</sup>	0.116 kW/unit
Measure life <sup>1</sup>	5 years
Incremental Cost <sup>1</sup>	\$67

[1] Taken from Morgan Measure Libraries

\*- If the appropriate field data required to complete this equation cannot be obtained, the deemed savings values in the table are to be used for each measure.

### Key Assumptions:

- Cold Water Supply Temperature: 60°F, Hot Water Supply Temperature (from sprayer) of 128°F
- Average use of 5.1 hour per week (approximately 265.20 hours per year)
- Assumes 100% EF water heater
- Baseline GPM assumed to be 2.78 GPM

### Low Flow Faucet Aerators

Current typical existing market (baseline)	≥2.5 gpm
Minimum threshold for credit	1.5 gpm
Estimated savings <sup>1</sup>	174 kWh
Change in usage calculation <sup>2</sup>	$\Delta\text{kWh} = [Q \times 8.33 \times T_d] / 3,413 / \text{EF}$
Estimated demand savings credit full size <sup>1</sup>	0.017 kW/unit
Measure life <sup>1</sup>	9 years
Incremental Cost <sup>1</sup>	\$12

[1] Taken from Morgan Measure Libraries

[2] Taken from AmerenUE Business TRM 2008

\*- If the appropriate field data required to complete this equation cannot be obtained, the deemed savings values in the table are to be used for each measure.

### Key Assumptions:

- $Q$  = flow rate savings, gallons per year = 1,048 gallons/yr  
=  $\Delta\text{GPM} \times 1 \text{ min per use} \times 365 \text{ days} \times 5.74 \text{ persons} \div 2 \text{ fixtures}^1$
- 8.33 = conversion factor (Btu/gal-°F)
- $T_d$  = Temperature difference between hot water setting and makeup water temperature = 68°F
- EF = Efficiency of electric water heater = 100%
- 3,413 = Btu per kWh

[1] Taken from Ameren Illinois Potential Study 2009 measure list.

## Commercial Pumps and Drives

Commercial pumps and drives can be deemed, but many of these measures will include sufficient variability in usage that the project would likely follow a custom analysis. It is important to identify the appropriate baseline efficiency when conducting pumps and drives savings calculations.

### Commercial Pumps for Process

## Appendix A – Technical Resource Manual

## Ameren Missouri

Current typical existing market (baseline)	N/A
Minimum threshold for credit	≥ 75% Pump Efficiency Improvement (> 5 HP); for HP < 5, see table below.
Estimated savings 10,000 – 50,000 BTU/h <sup>1</sup>	Average of 236 kWh/HP
Change in usage calculation <sup>2</sup>	$\Delta kWh = kW * t * (1 - \eta_1 / \eta_2)$
Estimated demand savings <sup>1</sup>	Average of 0.064 kW/HP
Measure life <sup>1</sup>	15 years
Incremental Cost <sup>1</sup>	See table below

[1] Taken from Morgan Measure Libraries

[2] Taken from Ohio TRM 2009

\*- If the appropriate field data required to complete this equation cannot be obtained, the deemed savings values in the table are to be used for each measure.

### Key Assumptions:

- T = annual hours of operation = 3,680 hours
- Load Factor = LF = 76%.
  - η1 = Efficiency of the original pumping system, %
  - η2 = Efficiency of the improved pumping system, %

## Appendix A – Technical Resource Manual

## Ameren Missouri

Motor Horsepower	Average Base Efficiency (%)	Average High Efficiency (%)
0.75	59.02	63.58
1	62.10	67.15
2	58.99	65.51
3	59.19	67.30
5	59.41	71.11

Pump HP	Eff Increase	kW Savings	kWh Savings	Increased Cost \$	kW / hp	Incremental Cost
1.5	5.66	0.547067	1,991	\$ 319	0.365	\$ 350.00
2.0	7.48	0.140911	513	\$ 467	0.070	\$ 350.00
3.0	7.19	0.157489	573	\$ 461	0.052	\$ 350.00
5.0	2.86	0.182356	664	\$ 75	0.036	\$ 341.00
5.0	21.3	2.5364	9,232	\$ 304	0.507	\$ 341.00
5.0	12.9	1.210178	4,405	\$ 754	0.242	\$ 341.00
5.0	13.75	0.431022	1,569	\$ 341	0.086	\$ 341.00
5.0	24.54	1.168733	4,254	\$ 610	0.234	\$ 341.00
7.5	7.48	0.505622	1,840	\$ 657	0.067	\$ 498.00
7.5	6.05	0.472467	1,720	\$ 498	0.063	\$ 498.00
10.0	2.96	0.281822	1,026	\$ 131	0.028	\$ 332.00
10.0	4.6	0.4476	1,629	\$ 332	0.045	\$ 332.00
10.0	12.25	1.110711	4,043	\$ 150	0.111	\$ 332.00
15.0	16.09	2.0142	7,332	\$ 585	0.134	\$ 585.00
20.0	2.45	0.348133	1,267	\$ 1,029	0.017	\$ 850.00
20.0	9.24	1.467133	5,340	\$ 498	0.073	\$ 850.00
20.0	4	0.936644	3,409	\$ 850	0.047	\$ 850.00

**Commercial Variable Frequency Drives for Process Pumping (VFD)**

Current typical existing market (baseline)	N/A
Minimum threshold for credit	VFD speed must be automatically controlled by differential pressure, flow, temperature, or other variable signal.
Estimated savings <sup>1</sup>	See Table Below
Change in usage calculation <sup>2</sup>	$\Delta kWh = BHP * 0.746 / \eta_{motor} \times HOURS \times ESF$
Estimated savings <sup>1</sup>	See Table Below
Measure life <sup>1</sup>	15 years
Incremental Cost <sup>1</sup>	See table below

[1] Taken from Morgan Measure Libraries

[2] Taken from Ohio TRM 2009

\*- If the appropriate field data required to complete this equation cannot be obtained, the deemed savings values in the table are to be used for each measure.

## Key Assumptions:

- Hours of operation = see chart below
- The average loading of the pumps analyzed was 86% pump capacity.
- Coincidence Factor (CF) = 0.78
- BHP = Brake horsepower of motor, should be collected with application.
- $\eta_{motor}$  = efficiency of motor being driven by VFD = 59%
- 0.746 = conversion factor HP to kW
- ESF = energy savings factor = 39%<sup>1</sup>

[1] Taken from Morgan Measure Libraries

Size	kWh Savings	kW Savings	Incremental Cost	Hours
3HP	3,246.2	0.686	\$ 1,845	3,713
5 HP	5,356.7	1.143	\$ 2,070	3,676
7.5 HP	8,116.2	1.714	\$ 2,860	3,713
10 HP	10,713.4	2.286	\$ 2,860	3,676
15 HP	16,232.3	3.429	\$ 3,265	3,713
20 HP	21,643.1	4.571	\$ 4,515	3,713
25 HP	27,053.9	5.714	\$ 5,120	3,713
30 HP	32,464.6	6.857	\$ 5,770	3,713
40 HP	43,286.2	9.143	\$ 8,095	3,713
50 HP	54,108.4	11.429	\$ 8,950	3,713

**Commercial Variable Frequency Drives for Air Compressors (VFD)**

Current typical existing market (baseline)	Screw Air Compressor with Modulation Control
Minimum threshold for credit	Screw Air Compressor with Variable Speed Drive (VSD) Control

Estimated savings <sup>1</sup>	5.82 kWh per HP
Estimated demand savings <sup>1</sup>	0.0014 kW per HP
Measure life <sup>1</sup>	15 years
Incremental Cost <sup>1</sup>	\$ 1 per HP

[1] Taken from Morgan Measure Libraries

## Commercial HVAC Applications

To most accurately measure energy and demand savings attributable to heating, ventilation, and air conditioning measures, building simulation modeling should be conducted (see Section 05 below), however, if the resources required to complete building simulation analysis are not available, the following equations can be used to estimate savings. If a measure does not have a savings algorithm associated with it, the deemed values represented in the table should be used.

### <150 Ton Water Cooled Centrifugal Chiller

Current typical existing market (baseline) <sup>1</sup>	0.70 kW/ton full-load efficiency 0.67 kW/ton IPLV
Minimum threshold for credit <sup>1</sup>	0.56 – 0.70 kW/ton full-load efficiency 0.34 – 0.60 kW/ton IPLV
Estimated savings credit per chiller for 0.56 kW/ton <sup>1</sup>	422 kWh/ton
Change in usage calculation <sup>2</sup>	$\Delta kWh = T(OH)(IPLV_{base} - IPLV_{ee})$
Estimated demand savings credit per chiller for 0.56 kW/ton <sup>1</sup>	0.142 kW/ton
Measure life <sup>1</sup>	20 years 25 years
Incremental Cost <sup>1</sup>	\$ 186/ton

[1] Taken from Morgan Measure Libraries

[2] Taken from AmerenUE Business TRM 2008

\*- If the appropriate field data required to complete this equation cannot be obtained, the deemed savings values in the table are to be used for each measure.

#### Key Assumptions:

- IPLV = Integrated Part Load Factor - The term IPLV is used to signify the cooling efficiency related to a typical (hypothetical) season rather than a single rated condition. The IPLV is calculated by determining the weighted average efficiency at part-load capacities specified by an accepted standard
- T = Capacity of chiller (tons) (assumed 560 tons)
- OH = Equivalent full load annual operating hours (hr)

### >150 to <300 Ton Water Cooled Centrifugal Chiller

Current typical existing market (baseline) <sup>1</sup>	0.63 kW/ton full-load efficiency 0.60 kW/ton IPLV
Minimum threshold for credit <sup>1</sup>	0.51 – 0.63 kW/ton full-load efficiency 0.30 – 0.54 kW/ton IPLV
Estimated savings credit per chiller for 0.51 kW/ton <sup>1</sup>	375 kWh/ton
Change in usage calculation <sup>2</sup>	$\Delta kWh = T(OH)(IPLV_{base} - IPLV_{ee})$
Estimated demand savings credit per chiller for 0.51 kW/ton <sup>1</sup>	0.128 kW/ton

## Appendix A – Technical Resource Manual

## Ameren Missouri

Measure life <sup>1</sup>	20 years 25 years
Incremental Cost <sup>1</sup>	\$ 143/ton

[1] Taken from Morgan Measure Libraries

[2] Taken from AmerenUE Business TRM 2008

\*- If the appropriate field data required to complete this equation cannot be obtained, the deemed savings values in the table are to be used for each measure.

### Key Assumptions:

- IPLV = Integrated Part Load Factor - The term IPLV is used to signify the cooling efficiency related to a typical (hypothetical) season rather than a single rated condition. The IPLV is calculated by determining the weighted average efficiency at part-load capacities specified by an accepted standard
- T = Capacity of chiller (tons) (assumed 560 tons)
- OH = Equivalent full load annual operating hours (hr)

### >300 Ton Water Cooled Centrifugal Chiller

Current typical existing market (baseline) <sup>1</sup>	0.58 kW/ton full-load efficiency 0.55 kW/ton IPLV
Minimum threshold for credit <sup>1</sup>	0.46 – 0.58 kW/ton full-load efficiency 0.29 – 0.49 kW/ton IPLV
Estimated savings credit per chiller for 0.46 kW/ton <sup>1</sup>	346 kWh/ton
Change in usage calculation <sup>2</sup>	$\Delta\text{kWh} = T(\text{OH})(\text{IPLV}_{\text{base}} - \text{IPLV}_{\text{ee}})$
Estimated demand savings credit per chiller for 0.46 kW/ton <sup>1</sup>	0.116 kW/ton
Measure life <sup>1</sup>	20 years 25 years
Incremental Cost <sup>1</sup>	\$ 112/ton

[1] Taken from Morgan Measure Libraries

[2] Taken from AmerenUE Business TRM 2008

\*- If the appropriate field data required to complete this equation cannot be obtained, the deemed savings values in the table are to be used for each measure.

### Key Assumptions:

- IPLV = Integrated Part Load Factor - The term IPLV is used to signify the cooling efficiency related to a typical (hypothetical) season rather than a single rated condition. The IPLV is calculated by determining the weighted average efficiency at part-load capacities specified by an accepted standard
- T = Capacity of chiller (tons) (assumed 560 tons)
- OH = Equivalent full load annual operating hours (hr)

**<150 Ton Water Cooled Screw Chiller**

Current typical existing market (baseline) <sup>1</sup>	0.79 kW/ton full-load efficiency 0.68 kW/ton IPLV
Minimum threshold for credit <sup>1</sup>	0.63 – 0.79 kW/ton full-load efficiency 0.38 – 0.62 kW/ton IPLV
Estimated savings credit per chiller for 0.38 kW/ton <sup>1</sup>	460 kWh/ton
Change in usage calculation <sup>2</sup>	$\Delta\text{kWh} = T(\text{OH})(\text{IPLV}_{\text{base}} - \text{IPLV}_{\text{ee}})$
Estimated demand savings credit per chiller for 0.78 kW/ton <sup>1</sup>	0.169 kW/ton
Measure life <sup>1</sup>	20 years 25 years
Incremental Cost <sup>1</sup>	\$ 165/ton

[1] Taken from Morgan Measure Libraries

[2] Taken from AmerenUE Business TRM 2008

\*- If the appropriate field data required to complete this equation cannot be obtained, the deemed savings values in the table are to be used for each measure.

## Key Assumptions:

- IPLV = Integrated Part Load Factor - The term IPLV is used to signify the cooling efficiency related to a typical (hypothetical) season rather than a single rated condition. The IPLV is calculated by determining the weighted average efficiency at part-load capacities specified by an accepted standard
- T = Capacity of chiller (tons) (assumed 560 tons)
- OH = Equivalent full load annual operating hours (hr)

**>150 to <300 Ton Water Cooled Screw Chiller**

Current typical existing market (baseline) <sup>1</sup>	0.72 kW/ton full-load efficiency 0.63 kW/ton IPLV
Minimum threshold for credit <sup>1</sup>	0.57 – 0.72 kW/ton full-load efficiency 0.34 – 0.57 kW/ton IPLV
Estimated savings credit per chiller for 0.57 kW/ton <sup>1</sup>	416 kWh/ton
Change in usage calculation <sup>2</sup>	$\Delta\text{kWh} = T(\text{OH})(\text{IPLV}_{\text{base}} - \text{IPLV}_{\text{ee}})$
Estimated demand savings credit per chiller for 0.57 kW/ton <sup>1</sup>	0.154 kW/ton
Measure life <sup>1</sup>	20 years 25 years
Incremental Cost <sup>1</sup>	\$ 125/ton

[1] Taken from Morgan Measure Libraries

[2] Taken from AmerenUE Business TRM 2008

\*- If the appropriate field data required to complete this equation cannot be obtained, the deemed savings values in the table are to be used for each measure.

## Appendix A – Technical Resource Manual

## Ameren Missouri

### Key Assumptions:

- IPLV = Integrated Part Load Factor - The term IPLV is used to signify the cooling efficiency related to a typical (hypothetical) season rather than a single rated condition. The IPLV is calculated by determining the weighted average efficiency at part-load capacities specified by an accepted standard
- T = Capacity of chiller (tons) (assumed 560 tons)
- OH = Equivalent full load annual operating hours (hr)

### >300 Ton Water Cooled Screw Chiller

Current typical existing market (baseline) <sup>1</sup>	0.64 kW/ton full-load efficiency 0.57 kW/ton IPLV
Minimum threshold for credit <sup>1</sup>	0.51 – 0.64 kW/ton full-load efficiency 0.31 – 0.51 kW/ton IPLV
Estimated savings credit per chiller for 0.51 kW/ton <sup>1</sup>	373 kWh/ton
Change in usage calculation <sup>2</sup>	$\Delta\text{kWh} = T(\text{OH})(\text{IPLV}_{\text{base}} - \text{IPLV}_{\text{ee}})$
Estimated demand savings credit per chiller for 0.51 kW/ton <sup>1</sup>	0.137 kW/ton
Measure life <sup>1</sup>	20 years 25 years
Incremental Cost <sup>1</sup>	\$ 93/ton

[1] Taken from Morgan Measure Libraries

[2] Taken from AmerenUE Business 2008 TRM

\*- If the appropriate field data required to complete this equation cannot be obtained, the deemed savings values in the table are to be used for each measure.

### Key Assumptions:

- IPLV = Integrated Part Load Factor - The term IPLV is used to signify the cooling efficiency related to a typical (hypothetical) season rather than a single rated condition. The IPLV is calculated by determining the weighted average efficiency at part-load capacities specified by an accepted standard
- T = Capacity of chiller (tons) (assumed 560 tons)
- OH = Equivalent full load annual operating hours (hr)

### Unitary Air Conditioner <65,000 BTU/hr

Current typical existing market (baseline) <sup>2</sup>	SEER 13
Minimum threshold for credit	SEER 14
Estimated savings credit <sup>1</sup>	65.23 kWh/ton
Change in usage calculation <sup>3</sup>	$\Delta\text{kWh} = (\text{BtuH}/1000) \times (1/\text{EER}_{\text{b}} - 1/\text{EER}_{\text{q}}) \times \text{EFLH}^*$
Estimated demand savings credit <sup>1</sup>	0.0746 kW/ton
Measure life <sup>1</sup>	15 years
Incremental Cost <sup>1</sup>	\$ 55.57/ton

[1] Taken from Morgan Measure Libraries

[2] Taken from National Appliance Energy Conservation Act (NAECA)

[3] Taken from AmerenUE Business TRM 2008

\*- If the appropriate field data required to complete this equation cannot be obtained, the deemed savings values in the table are to be used for each measure.



## Key Assumptions:

- BtuH = Cooling capacity in Btu/Hour – This value comes from ARI or AHAM rating or manufacturer data.
- EERb = Efficiency rating of the baseline unit. For units < 65,000, SEER and HSPF should be used for cooling and heating savings, respectively = 13 SEER
- EERq = Efficiency rating of the High Efficiency unit – This value comes from the ARI or AHAM directories or manufacturer data. For units < 65,000, SEER and HSPF should be used for cooling and heating savings, respectively = 14 SEER.
- CF = Coincidence Factor – This value represents the percentage of the total load which is on during electric system's Peak. This value will be based on existing measured usage and determined as the average number of operating hours during the peak period.
- EFLH = Equivalent Full Load Hours – This represents a measure of energy use by season during the on-peak and off peak periods. This value will be determined by existing measured data of kWh during the period divided by kW at design conditions

**Unitary Air Conditioner <135,000 to <240,000 BTU/hr (3 phase)**

Current typical existing market (baseline) <sup>2</sup>	9.5 EER
Minimum threshold for credit	11.0 EER
Estimated savings credit <sup>1</sup>	119 kWh/ton
Change in usage calculation <sup>3</sup>	$\Delta\text{kWh} = (\text{BtuH}/1000) \times (1/\text{EERb} - 1/\text{EERq}) \times \text{EFLH} *$
Estimated demand savings credit <sup>1</sup>	0.136 kW/ton
Measure life <sup>1</sup>	15 years
Incremental Cost <sup>1</sup>	\$ 110.89/ton

[1] Taken from Morgan Measure Libraries

[2] Taken from American Society of Heating, Refrigerating and Air-Conditioning Engineers (ASHRAE) 90.1-2004

[3] Taken AmerenUE Business TRM 2008

\*- If the appropriate field data required to complete this equation cannot be obtained, the deemed savings values in the table are to be used for each measure.

## Key Assumptions:

- BtuH = Cooling capacity in Btu/Hour – This value comes from ARI or AHAM rating or manufacturer data.
- EERb = Efficiency rating of the baseline unit. For units < 65,000, SEER and HSPF should be used for cooling and heating savings, respectively = 9.5 EER
- EERq = Efficiency rating of the High Efficiency unit – This value comes from the ARI or AHAM directories or manufacturer data. For units < 65,000, SEER and HSPF should be used for cooling and heating savings, respectively = 11 EER.
- CF = Coincidence Factor – This value represents the percentage of the total load which is on during electric system's Peak. This value will be based on existing measured usage and determined as the average number of operating hours during the peak period.
- EFLH = Equivalent Full Load Hours – This represents a measure of energy use by season during the on-peak and off peak periods. This value will be determined by existing measured data of kWh during the period divided by kW at design conditions

## Appendix A – Technical Resource Manual

## Ameren Missouri

### Unitary Air Conditioner >760,000 BTU/hr (3 phase)

Current typical existing market (baseline) <sup>2</sup>	9.0 EER
Minimum threshold for credit	10.0 EER
Estimated savings credit <sup>1</sup>	92.12 kWh/ton
Change in usage calculation <sup>3</sup>	$\Delta\text{kWh} = (\text{BtuH}/1000) \times (1/\text{EERb}-1/\text{EERq}) \times \text{EFLH}^*$
Estimated demand savings credit <sup>1</sup>	0.105 kW/ton
Measure life <sup>1</sup>	15 years
Incremental Cost <sup>1</sup>	\$ 98.38/ton

[1] Taken from Morgan Measure Libraries

[2] Taken from ASHRAE 90.1-2004

[3] Taken from AmerenUE Business TRM 2008

\*- If the appropriate field data required to complete this equation cannot be obtained, the deemed savings values in the table are to be used for each measure.

#### Key Assumptions:

- BtuH = Cooling capacity in Btu/Hour – This value comes from ARI or AHAM rating or manufacturer data.
- EERb = Efficiency rating of the baseline unit. For units < 65,000, SEER and HSPF should be used for cooling and heating savings, respectively = 9 EER
- EERq = Efficiency rating of the High Efficiency unit – This value comes from the ARI or AHAM directories or manufacturer data. For units < 65,000, SEER and HSPF should be used for cooling and heating savings, respectively = 10 EER.
- CF = Coincidence Factor – This value represents the percentage of the total load which is on during electric system's Peak. This value will be based on existing measured usage and determined as the average number of operating hours during the peak period.
- EFLH = Equivalent Full Load Hours – This represents a measure of energy use by season during the on-peak and off peak periods. This value will be determined by existing measured data of kWh during the period divided by kW at design conditions

### Ground Source Heat Pump <135,000 BTU/hr

Current typical existing market (baseline) <sup>1</sup>	13.4 EER
Minimum threshold for credit <sup>1</sup>	17 EER
Estimated savings credit <sup>1</sup>	240 kWh/ton
Change in usage calculation <sup>2</sup>	$\Delta\text{kWh} = (\text{BtuH}/1000) \times (1/\text{EERb}-1/\text{EERq}) \times \text{EFLH}^*$
Estimated demand savings <sup>1</sup>	0.114 kW/ton
Measure life <sup>1</sup>	15 years
Incremental Cost <sup>1</sup>	\$ 180/ton

[1] Taken from Morgan Measure Libraries

[2] Taken from AmerenUE Business TRM 2008

\*- If the appropriate field data required to complete this equation cannot be obtained, the deemed savings values in the table are to be used for each measure.

#### Key Assumptions:

## Appendix A – Technical Resource Manual

## Ameren Missouri

- BtuH = Cooling capacity in Btu/Hour – This value comes from ARI or AHAM rating or manufacturer data.
- EERb = Efficiency rating of the baseline unit. For units < 65,000, SEER and HSPF should be used for cooling and heating savings, respectively = 13.4 EER
- EERq = Efficiency rating of the High Efficiency unit – This value comes from the ARI or AHAM directories or manufacturer data. For units < 65,000, SEER and HSPF should be used for cooling and heating savings, respectively = 17 EER.
- CF = Coincidence Factor – This value represents the percentage of the total load which is on during electric system's Peak. This value will be based on existing measured usage and determined as the average number of operating hours during the peak period.
- EFLH = Equivalent Full Load Hours – This represents a measure of energy use by season during the on-peak and off peak periods. This value will be determined by existing measured data of kWh during the period divided by kW at design conditions

### Ground Source Heat Pump <135,000 BTU/hr

Current typical existing market (baseline) <sup>1</sup>	13.4 EER
Minimum threshold for credit <sup>1</sup>	19 EER
Estimated savings credit <sup>1</sup>	305 kWh/ton
Change in usage calculation <sup>2</sup>	$\Delta\text{kWh} = (\text{BtuH}/1000) \times (1/\text{EERb}-1/\text{EERq}) \times \text{EFLH}^*$
Estimated demand savings credit <sup>1</sup>	0.147 kW/ton
Measure life <sup>1</sup>	15 years
Incremental Cost <sup>1</sup>	\$ 180/ton

[1] Taken from Morgan Measure Libraries

[2] Taken from AmerenUE Business TRM 2008

\*- If the appropriate field data required to complete this equation cannot be obtained, the deemed savings values in the table are to be used for each measure.

#### Key Assumptions:

- BtuH = Cooling capacity in Btu/Hour – This value comes from ARI or AHAM rating or manufacturer data.
- EERb = Efficiency rating of the baseline unit. For units < 65,000, SEER and HSPF should be used for cooling and heating savings, respectively = 13.4 EER
- EERq = Efficiency rating of the High Efficiency unit – This value comes from the ARI or AHAM directories or manufacturer data. For units < 65,000, SEER and HSPF should be used for cooling and heating savings, respectively = 19 EER.
- CF = Coincidence Factor – This value represents the percentage of the total load which is on during electric system's Peak. This value will be based on existing measured usage and determined as the average number of operating hours during the peak period.
- EFLH = Equivalent Full Load Hours – This represents a measure of energy use by season during the on-peak and off peak periods. This value will be determined by existing measured data of kWh during the period divided by kW at design conditions

### Heat Pump <65,000 BTU/hr

Current typical existing market (baseline) <sup>1</sup>	13.0 SEER, 7.7 HSPF
Minimum threshold for credit <sup>1</sup>	14 SEER, 7.97 HSPF
Estimated savings credit <sup>2</sup>	114 kWh/ton

## Appendix A – Technical Resource Manual

## Ameren Missouri

Change in usage calculation <sup>2</sup>	See equation below.
Estimated demand savings credit <sup>1</sup>	0.079 kW/ton
Measure life <sup>1</sup>	15 years
Incremental Cost <sup>1</sup>	\$ 73.5/ton

[1] Taken from Morgan Measure Libraries

[2] Ohio TRM 2009

\*- If the appropriate field data required to complete this equation cannot be obtained, the deemed savings values in the table are to be used for each measure.

For units with cooling capacities less than 65 kBtu/h:

Annual kWh Savings = Annual kWh Savingscool + Annual kWh Savingsheat

Annual kWh Savingscool = (kBtu/h) \* [(1/SEERbase) – (1/SEERee)] \* EFLHcool

Annual kWh Savingsheat = (kBtu/h) \* [(1/HSPFbase) – (1/HSPFee)] \* EFLHheat

Summer Coincident Peak kW Savings = (kBtu/h) \* [(1/EERbase) – (1/EERee)] \* CF

Key Assumptions:

- kBtu/hcool = capacity of the cooling equipment in kBtu per hour (1 ton of cooling capacity equals 12 kBtu/h). = Actual installed
- SEERbase = Seasonal Energy Efficiency Ratio of the baseline equipment; see table below for values.
- SEERee = Seasonal Energy Efficiency Ratio of the energy efficient equipment.
- = Actual installed
- EFLHcool = cooling mode equivalent full load hours; see table below for default values
- HSPFbase = Heating Seasonal Performance Factor of the baseline equipment; see table above for values.
- HSPFee = Heating Seasonal Performance Factor of the energy efficient equipment.
- = Actual installed
- EFLHheat = heating mode equivalent full load hours; see table above for default values.
- kBtu/hheat = capacity of the heating equipment in kBtu per hour.  
= Actual installed
- 3412= Btu per Wh.

### Heat Pump >135,000 to <240,000 BTU/hr

Current typical existing market (baseline) <sup>1</sup>	9.1 EER
Minimum threshold for credit <sup>1</sup>	10 EER
Estimated savings credit <sup>1</sup>	143 kWh/ton
Change in usage calculation <sup>2</sup>	$\Delta\text{kWh} = (\text{BtuH}/1000) \times (1/\text{EERb} - 1/\text{EERq}) \times \text{EFLH}^*$
Estimated demand savings credit <sup>1</sup>	0.095 kW/ton
Measure life <sup>1</sup>	15 years
Incremental Cost <sup>1</sup>	\$ 125/ton

[1] Taken from Morgan Measure Libraries

[2] Taken from AmerenUE Business TRM 2008

\*- If the appropriate field data required to complete this equation cannot be obtained, the deemed savings values in the table are to be used for each measure.

Key Assumptions:

- BtuH = Cooling capacity in Btu/Hour – This value comes from ARI or AHAM rating or manufacturer data.
- EERb = Efficiency rating of the baseline unit. For units < 65,000, SEER and HSPF should be used for cooling and heating savings, respectively = 9.1 EER
- EERq = Efficiency rating of the High Efficiency unit – This value comes from the ARI or AHAM directories or manufacturer data. For units < 65,000, SEER and HSPF should be used for cooling and heating savings, respectively = 10 EER.
- CF = Coincidence Factor – This value represents the percentage of the total load which is on during electric system's Peak. This value will be based on existing measured usage and determined as the average number of operating hours during the peak period.
- EFLH = Equivalent Full Load Hours – This represents a measure of energy use by season during the on-peak and off peak periods. This value will be determined by existing measured data of kWh during the period divided by kW at design conditions

### Heat Pump >240,000 BTU/hr

Current typical existing market (baseline) <sup>1</sup>	8.8 EER
Minimum threshold for credit <sup>1</sup>	10 EER
Estimated savings credit <sup>2</sup>	175 kWh/ton
Change in usage calculation <sup>2</sup>	$\Delta\text{kWh} = (\text{BtuH}/1000) \times (1/\text{EERb} - 1/\text{EERq}) \times \text{EFLH}^*$
Estimated demand savings credit <sup>1</sup>	0.130 kW/ton
Measure life <sup>1</sup>	15 years
Incremental Cost <sup>1</sup>	\$ 130/ton

[1] Taken from Morgan Measure Libraries

[2] Taken from AmerenUE Business TRM 2008

\*- If the appropriate field data required to complete this equation cannot be obtained, the deemed savings values in the table are to be used for each measure.

#### Key Assumptions:

- BtuH = Cooling capacity in Btu/Hour – This value comes from ARI or AHAM rating or manufacturer data.
- EERb = Efficiency rating of the baseline unit. For units < 65,000, SEER and HSPF should be used for cooling and heating savings, respectively = 8.8 EER
- EERq = Efficiency rating of the High Efficiency unit – This value comes from the ARI or AHAM directories or manufacturer data. For units < 65,000, SEER and HSPF should be used for cooling and heating savings, respectively = 10 EER.
- CF = Coincidence Factor – This value represents the percentage of the total load which is on during electric system's Peak. This value will be based on existing measured usage and determined as the average number of operating hours during the peak period.
- EFLH = Equivalent Full Load Hours – This represents a measure of energy use by season during the on-peak and off peak periods. This value will be determined by existing measured data of kWh during the period divided by kW at design conditions

**Guest Room Energy Management System – Electric Heating (Hotel/Lodging)**

Current typical Hotel Room Energy Management System <sup>1</sup>	Manual Controls
Minimum threshold for credit <sup>1</sup>	Keycard occupancy sensors and passive infrared occupancy sensors
Estimated savings credit <sup>1</sup>	1,112 kWh per room
	See equation below
Estimated demand savings credit <sup>1</sup>	.0.088 kW
Measure life <sup>1</sup>	9 years
Incremental Cost <sup>1</sup>	\$ 600 per room

[1] Taken from Morgan Measure Libraries

## Key Assumptions

- Tons = 1,900 square foot home

## Commercial Miscellaneous

### Tractor Heater Timers

Current typical existing market (baseline) <sup>1</sup>	N/A
Minimum threshold for credit <sup>1</sup>	N/A
Estimated savings credit <sup>1</sup>	576 kWh
Change in usage calculation <sup>1</sup>	
Measure life <sup>1</sup>	10 years
Incremental Cost <sup>1</sup>	\$ 35

[1] Taken from Focus on Energy Evaluation Business Programs: Deemed Savings Manual v1.0 March 22, 2010.

For custom – application specific, see Ohio TRM language/Lockheed Martin how they analyze projects.

\*- If the appropriate field data required to complete this equation cannot be obtained, the deemed savings values in the table are to be used for each measure.

## Key Assumptions:

- P = average power of engine block heater = 1,000 watts
- Hours – reduction in hours block heater is used = 8 hours
- Days = number of operating days per year = 90 days
- UF = usage fraction = 0.8

### Desktop Virtualization – Thin Client 2

Current typical existing market (baseline) <sup>1</sup>	Energy Star 3.0 desktop computer
Minimum threshold for credit <sup>1</sup>	Hardware/Software replacing desktop
Estimated savings credit <sup>1</sup>	541 kWh
Estimated demand savings credit <sup>1</sup>	0.070 kW
Measure life <sup>1</sup>	5 years
Incremental Cost <sup>1</sup>	\$ 116

[1] Information taken from Xcel Minnesota TRM.

$$kWh\ savings = (Base\ UEC * AOH - Efficient\ UEC * AOH) / 1000$$

## Key Assumptions:

- Annual Hours of Operation (AOH) = 7,311
- Baseline Energy Consumption = 96 watts
- Efficient Energy Consumption = 22 watts

Due to the progressive nature of this measure, EM&V activities will be undertaken to verify this measure's assumptions in this first MEEIA cycle.

**Energy Star Personal Computer (PC)**

Current typical existing market (baseline) <sup>1</sup>	Desktop computer meeting ENERGY STAR 3.0 with a standard efficiency power supply
Minimum threshold for credit <sup>1</sup>	ENERGY STAR 5.0 Desktop Computer
Estimated savings credit <sup>1</sup>	149 kWh
Estimated demand savings credit <sup>1</sup>	0.030 kW
Measure life <sup>1</sup>	4 years
Incremental Cost <sup>1</sup>	\$ 25

[1] Taken from Lockheed Martin proposal October 2012. Information taken from Energy Star Calculator.

$$kWh\ savings = Base\ UEC - Efficient\ UEC$$



## Appendix A – Technical Resource Manual

## Ameren Missouri

### PC Power Management Software

Current typical existing market (baseline) <sup>1</sup>	Desktop PC, not centrally power managed
Minimum threshold for credit <sup>1</sup>	Centrally power managed
Estimated savings credit <sup>1</sup>	200 kWh
Estimated demand savings credit <sup>1</sup>	0.000 kW
Measure life <sup>1</sup>	4 years
Incremental Cost <sup>1</sup>	\$ 20

[1] Taken from Lockheed Martin proposal October 2012.

#### Key Assumptions:

- Energy savings of typical PC usage in hospital, small office, large office and school setting was analyzed.
- The term “PC”, “Computer”, or “end point” refers to a single-user computer as it is defined by EPA’s Program Requirements for Computers, Version 5.0.

### Window Replacement

Current typical existing market (baseline) <sup>1</sup>	International Energy Conservation Code (IECC) 2004
Minimum threshold for credit <sup>1</sup>	Above IECC 2009
Estimated savings credit <sup>1</sup>	30,575 kWh
Estimated savings credit	6.413 kW
Measure life <sup>1</sup>	20 years
Incremental Cost <sup>1</sup>	\$ 13,394

[1] Taken Morgan Measure Libraries (GEP Potential Study Measure list)

#### Key Assumptions:

- Savings are on a per building basis.

## Commercial Optimization Measures

### Chilled Water Reset Controls

Current typical existing market (baseline)	45°F fixed chilled-water temperature setpoint
Minimum threshold for credit	Reset water temperature to increase by 5 or 10 degrees
Estimated savings for 5 degree reset <sup>1</sup>	74 kWh/ton
Estimated savings for 10 degree reset <sup>1</sup>	89 kWh/ton
Estimated demand savings for 5 degree reset <sup>1</sup>	0.0058 kW/ton
Estimated demand savings for 10 degree reset <sup>2</sup>	0.0064 kW/ton
Measure life <sup>1</sup>	5 years
Incremental Cost <sup>1</sup>	\$ 0.80 per ton

[1] Taken from Morgan Measure Libraries

## Appendix A – Technical Resource Manual

## Ameren Missouri

### Key Assumptions:

- Tons = 612.4
- Total kWh savings for 5 degree reset = 45,821.1 kWh
- Total kW savings for 5 degree rest = 3.580 kW
- Total kWh savings for 10 degree rest = 54,362.9 kWh
- Total kW savings for 10 degree reset = 3.928 k

### Energy Management System

Current typical existing market (baseline)	Constant chilled water temperature setpoint, loop pumps operating 24/7
Minimum threshold for credit	Chilled water temperature setback and on/off scheduling of loop pumps
Estimated savings credit <sup>1</sup>	0.832 kWh per ft <sup>2</sup>
Estimated demand savings credit <sup>1</sup>	0.000083283 per ft <sup>2</sup>
Measure life <sup>1</sup>	15 years
Incremental Cost <sup>1</sup>	\$ 0.32 per ft <sup>2</sup>

[1] Taken from Morgan Measure Libraries

### Key Assumptions:

- Tons = 612.4
- Total kWh savings for 5 degree reset = 45,821.1 kWh
- Total kW savings for 5 degree rest = 3.580 kW
- Total kWh savings for 10 degree rest = 54,362.9 kWh
- Total kW savings for 10 degree reset = 3.928 kW

### Refrigerant Charging Correction

Current typical existing market (baseline)	Cooling capacity and EIR degraded by 10% to reflect “typical” refrigerant charge
Minimum threshold for credit	Standard cooling performance – proper refrigerant charge; 10% EER improvement
Estimated savings credit <sup>1</sup>	96.19 kWh per ft <sup>2</sup>
Estimated demand savings credit <sup>1</sup>	0.11 kW per ft <sup>2</sup>
Measure life <sup>1</sup>	10 years
Incremental Cost <sup>1</sup>	\$ 38.35 per ft <sup>2</sup>

[1] Taken from Morgan Measure Libraries

### Key Assumptions:

- Tons = 235.8
- Total kWh savings for 10% EER improvement = 22,680.5kWh
- Total kW savings for 10% EER improvement = 26.075 kW

**Optimized Cooling Controls**

Current typical existing market (baseline)	Digital Control of Cooling Systems (Basic)
Minimum threshold for credit	Optimize to achieve 10% Improvement in building's cooling load
Estimated savings credit <sup>1</sup>	16,325 kWh
Estimated demand savings credit <sup>1</sup>	2.238 kW
Measure life <sup>1</sup>	15 years
Incremental Cost <sup>1</sup>	\$ 1,568 per project

[1] Taken from Morgan Measure Libraries (Cadmus Potential Study Measure list)

## Key Assumptions:

- Assumes 10% savings of building's cooling energy consumption by optimizing the building's existing Digital Control System

**Optimized Heating Controls**

Current typical existing market (baseline)	Digital Control of Heating Systems (Basic)
Minimum threshold for credit	Optimize to achieve 10% Improvement in building's heating load
Estimated savings credit <sup>1</sup>	7,053 kWh
Estimated demand savings credit <sup>1</sup>	0.967 kW
Measure life <sup>1</sup>	15 years
Incremental Cost <sup>1</sup>	\$ 760 per project

[1] Taken from Morgan Measure Libraries (Cadmus Potential Study Measure list)

## Key Assumptions:

- Assumes 10% savings of building's heating energy consumption by optimizing the building's existing Digital Control System

**Compressed Air Optimization**

Current typical existing market (baseline)	N/A
Minimum threshold for credit	20% Improvement in air compressor energy consumption
Estimated savings credit <sup>1</sup>	200 kWh
Estimated demand savings credit <sup>1</sup>	0.026 kW
Measure life <sup>1</sup>	10 years
Incremental Cost <sup>1</sup>	\$ 16 per project

[1] Taken from Morgan Measure Libraries (ICF Program Model)

## Key Assumptions:

- Assumes 20% improvement over base case

## Custom Project Analysis Methodology<sup>7</sup>

The C&I Custom projects typically require substantial analytic rigor to identifying project savings and costs. While the nature of Custom projects can vary dramatically, most commonly found Custom measures can be grouped into 14 categories:

- Lighting Improvements (fixture upgrades, except for exit signs and controls)
- Lighting Improvements (Exit signs and controls)
- Packaged Air-Conditioners and Heat Pumps (includes RTUs, ASHPs, WSHPs, GSHPs)
- Chiller Replacements
- Cooling Tower Replacements
- Refrigeration System Replacements
- Motor Drive Installations (i.e. variable-frequency drives [VFDs] )
- Compressed-Air Systems
- Controls and Energy Management Systems (EMS)
- Domestic Water Heating (various options)
- Pump, Fan, Piping, and Duct Improvements
- Process Upgrades
- All Other

Some measures involve replacing an item of equipment with a similar, more-efficient model, while others entail enhancing the performance of existing equipment. For example, a measure may consist of modifying the programming of a control system and perhaps also adding one or more sensors and/or circuit-control devices, or it may involve modifying an existing pump or changing a piping system to reduce pressure drop, such that the motor driving the pump draws less power.

In the case of eligible motor upgrades and the installation of Variable Frequency Drive (VFD) drives on motors, this category will be credited with the savings irrespective of where the motor is located, unless the motor is part of a new item of equipment. For example, replacing the motor driving a fan on a cooling tower is a Motor measure, but replacing the entire cooling tower, which includes a new fan motor, is a Cooling Tower Measure.

A Technical Analysis Study (TAS) or energy savings estimate is required for all Custom projects. An energy savings estimate can be provided by the customer or a contractor. The Program engineering staff will review all TAS reports and energy savings estimates to ensure all assumptions are reasonable and that the study is based on sound engineering methodology. When a TAS Report , it will contain complete documentation for the proposed project, and forms a vital element for the subsequent Impact Evaluation performed by the evaluation contractor. The TAS is also often used by the customer to get funding approval. More specifically, the TAS:

- Identifies the customer (organization), key customer representatives and their contact information, and the location of the facility that will host the proposed project.
- Describes the host facility (typically with a photograph and/or sketch showing site layout or floor plan).
- Documents monthly electricity use, and identifies Ameren Missouri account number and meter number.
- Describes the baseline equipment and provides its electricity-use (with estimated load shape<sup>8</sup>) and estimated annual O&M costs.

<sup>7</sup> Taken from Technical Resource Manual for AmerenUE – Business Energy Efficiency 2008 – 2011. Drafted by Lockheed Martin Energy Services.

<sup>8</sup> Load shape expressed as monthly kWh and kW.

- Describes the new equipment to be added, together with key performance specifications and expected lifetime, or otherwise completes the description of the measure (i.e., Energy Management System (EMS) reprogramming and new control functions).
- Provides estimated electricity-use (and estimated load shape) for the retrofit condition.
- Provides the energy and demand savings calculations,<sup>9</sup> together with 1) the source of input parameter numbers, and 2) justification for each assumption made.
- Provides the cost to implement the project, together with a cost breakdown and, when possible, written quotations for major equipment item(s) and estimates of ongoing annual O&M costs.
- Provides the estimated financial incentive and estimated annual cost savings, together with the financial metric(s) requested by the customer (i.e., simple payback, IRR, ROI).

As it is noted above, some measures may involve modifying existing controls or energy management systems so they perform more functions and act more effectively to minimize electricity use while still producing the desired or needed service outputs as a function of time. Examples include the installation of Variable Air Volume (VAV) fans and sensors and the installation of a multistage efficient chiller, with each of these new systems controlled by an existing energy management system. This type of project will involve reprogramming of the EMS for the new control functions. *It is most important that the TAS fully describe the new equipment recommended, the new ventilation and chiller controls strategies to be implemented, and the specific EMS control functions that require reprogramming.*

After the TAS is submitted together with an application signed by the customer that references the TAS, an engineer on the Program staff will formally review it and independently check the savings calculations. The TAS will either be approved or returned to the customer with a written explanation of what modifications are needed. When modifications are required, the revision number and date are noted on the cover, new signatures are affixed, and the TAS is resubmitted.

After final approval, the customer is authorized to proceed with implementing the project. Program staff will monitor progress and offer advice if this is needed and it is feasible for program staff to provide this assistance.

### **Calculating Custom Energy and Demand Savings**

The equations used in this protocol assume that the project has a single measure. If the project has multiple measures, these calculations shall be repeated for each measure in such a way as to capture interactive effects.

### **Lighting Improvements**

This measure category involves a retrofit of the lighting system at C&I facilities. Typically, these facilities have a significant lighting end-use consumption, and will have ceiling or high-bay lighting fixtures and exterior lighting in the parking areas as well for advertising and security. Typical replacement HID or T-8 linear fluorescent high output fixtures are high output T-8 or T-5 linear fluorescent fixtures. Additionally, in areas with variable occupancy, motion sensors can be employed to reduce the operating hours of the lighting equipment.

Baseline Calculations: An audit is performed to determine the total number of fixtures per lamp/ballast combination. The lighting system demand (kW) is typically derived from Standard Fixture Wattage Tables.

<sup>9</sup> Reductions in Greenhouse Gas emissions or other environmental data should be included when available.

This table is an average of wattages for lamp/ballast combinations from several lighting manufacturers. The energy consumption for each line item is calculated with the following equation:

$$\text{kWh} = \text{WATTS}_{\text{base}} * \text{HOURS} * \text{IF} / 1000$$

Where:

WATTS<sub>base</sub> = Baseline lighting system wattage  
 HOURS = Lighting equipment annual operating hours (hrs)

**Energy Savings:** The methodology to estimate the retrofit energy consumption is identical to the calculation described above for the baseline. The retrofit demand (kW) consumption is more likely to utilize manufacturer's specifications. If lighting controls are part of the measure, the percent hour's reduction will be estimated based on observations of facility occupancy patterns, interviews with facility personnel, and/or standard reductions used in current California Utility Customized Incentive Programs.

$$\text{kWh} = \text{WATTS}_{\text{ee}} * \text{HOURS} * \text{IF} / 1000$$

Where:

WATTS<sub>ee</sub> = Efficient lighting system wattage  
 HOURS = Lighting equipment annual operating hours (hrs)

The energy savings result for the baseline consumption less the total retrofit consumption, with interaction effects factored in are:

$$\Delta \text{kWh} = ((\text{WATTS}_{\text{base}} - \text{WATTS}_{\text{ee}}) * \text{HOURS} * \text{IF}) / 1000$$

**Demand Reduction** - Demand savings result when the demand of the system is reduced during the summer peak period. Since the lighting system is non-weather dependent, the demand reduction is constant throughout the year. Any reduction in demand due to controls will only be included if significant variable occupancy will be achieved during the peak summer period. In this instance, the proportional retrofit demand will be included based on the expected reduction in hours.

$$\Delta \text{kW} = ((\text{WATTS}_{\text{base}} - \text{WATTS}_{\text{ee}}) * \text{CF} * \text{IF}) / 1000$$

The following list defines the various terms that appear in the foregoing equations:

CF = Coincidence Factor (fraction of the maximum power draw of all equipment involved in the measure that occurs during Ameren Missouri's peak system demand period)

IF = Interactive factor (additional savings attributable to reduction in heating or cooling costs associated with the new efficient technology).

### HVAC Direct Expansion (DX)

It is recommended that savings be estimated using a computer simulation (eQuest or DOE-2), but as an alternative the savings can be calculated using the following method:

$$\Delta \text{kW} = (\text{BtuH}/1000) * (1/\text{EERb} - 1/\text{EERq}) * \text{CF}$$

$$\Delta \text{kWh} = (\text{BtuH}/1000) * (1/\text{EERb} - 1/\text{EERq}) * \text{EFLH}$$

Definition of Variables:

- BtuH = Cooling capacity in Btu/Hour – This value comes from ARI or AHAM rating or manufacturer data.
- EERb = Efficiency rating of the baseline unit. This data is found in the HVAC and Heat Pump verification summary table. For units < 65,000, SEER and HSPF should be used for cooling and heating savings, respectively.

- EERq = Efficiency rating of the High Efficiency unit – This value comes from the ARI or AHAM directories or manufacturer data. For units < 65,000, SEER and HSPF should be used for cooling and heating savings, respectively.
- CF = Coincidence Factor – This value represents the percentage of the total load which is on during electric system’s Peak Window. This value will be based on existing measured usage and determined as the average number of operating hours during the peak window period.
- EFLH = Equivalent Full Load Hours – This represents a measure of energy use by season during the on-peak and off peak periods. This value will be determined by existing measured data of kWh during the period divided by kW at design conditions.

### Chillers

This measure involves replacing an existing chiller with a high efficiency chiller. Energy is saved as a result of increasing the efficiency of the chiller system.

**Baseline Calculation:** There have been significant advancements in recent years in the efficiency of cooling equipment. The simple baseline calculation is to utilize the full load efficiency from the chiller manufacturer’s specifications. This is considered a conservative calculation since more savings are likely achieved during part load conditions. The equation for this calculation is:

$$kWh_{Base} = T(OH)(\eta_{Ex})$$

Where:

kWh <sub>Base</sub>	=	Energy consumption of existing equipment (kWh)
T	=	Capacity of chiller (tons)
OH	=	Equivalent full load annual operating hours (hr)
η <sub>Ex</sub>	=	Full load efficiency of existing chiller (kW/ton)

A complex analysis requires a distribution of operation at part load conditions. The efficiency of the chiller will change depending on the percent loading on the chiller. Manufacturer’s specifications may include part load efficiencies. Alternatively, ASHRAE 90.1 generic chiller curves can be used to develop part-load efficiencies.

For weather-dependent loads, a weather BIN analysis is a common method to apply accurate operating hours within part load conditions. Typical Meteorological Year (TMY) weather data should be examined in comparison with trend data to evaluate the chiller load and annual hours in each weather BIN. In many industrial facilities, the chiller load is dependent on the production. In this case, production records can be used in conjunction with trend data to develop the annual load profile.

Alternatively, if trend data does not exist, assumption can be made based on interviews with facility personnel and observations of chiller operation during facility audits. The equation above is carried out in each load bin.

$$kWh_{Base} = \sum T(OH)(\eta_{Ex})$$

Where:

kWh <sub>Base</sub>	=	Energy consumption of existing equipment (kWh)
T	=	Cooling load at given part load condition (tons)
OH	=	Annual operating hours at given part load condition (hr)
η <sub>Ex</sub>	=	Efficiency of existing chiller at given part load condition (kW/ton)

**Measure Life:** 20 years with proper maintenance.

**Retrofit Electricity Demand and Energy Consumption:** The existing operating profile is the basis for the retrofit consumption. Since the installation of the chiller will not affect the building load or operating hours, these parameters are identical to the existing analysis. The identical equations are used above with the insertion of the retrofit efficiency.

$$kWh_{Ret} = T(OH)(\eta_{Ret})$$

Where:

$kWh_{Ret}$  = Retrofit energy consumption (kWh)  
 T = Capacity of chiller (tons)  
 OH = Equivalent full load annual operating hours (hr)  
 $\eta_{Ret}$  = Full load efficiency for retrofit chiller (kW/ton)

Or:

$$kWh_{Ret} = \sum T(OH)(\eta_{Ret})$$

Where:

$kWh_{Ret}$  = Retrofit energy consumption (kWh)  
 T = Cooling load at given part load condition (tons)  
 OH = Annual operating hours at given part load condition (hr)  
 $\eta_{Ret}$  = Efficiency of retrofit chiller at given part load condition (kW/ton)

The electricity demand and energy savings are calculated as follows.

$$kW_{Saved} = kW_{base} - kW_{Ret}$$

$$kWh_{Saved} = kWh_{base} - kWh_{Ret}$$

### Chiller Replacement

This measure involves the replacement of an existing chiller with a more efficient chiller. The following equation applies.

$$kW_{Saved} = (\eta_{Ext} - \eta_{Ret})(T)$$

The kWh energy savings have been estimated based on an assumed annual load factor of 55%.

$$kWh_{Saved} = (\eta_{Saved})(T)(LF)(Hr)$$

### Free Cooling

Weather data is used to identify the annual hours in which outdoor air conditions are sufficient to provide water at a desirable temperature. Typically, demand savings may not be present with this measure because the process systems require water temperatures around 55-65°F and a cooling tower cannot meet these temperatures during the peak period. However, in many industrial facilities, air compressors are currently being cooled by chilled water. This equipment can be cooled with as high as 90°F water.

$$kWh_{Save} = (Tons) \left( \frac{kW}{Ton} \right)_{Chill} (Hr)_{Free}$$

### Chilled Water Pipe Insulation

The industry standard 3E+ insulation software<sup>3</sup> can be used as the basis. This program calculates the heat loss in bare and insulated pipes and is identified by the DOE Industrial Technologies Program as an assessment tool for insulation.

$$kW_{Saved} = (HL_{3E+})(\eta_{Chill})$$

$$kWh_{Saved} = (kW_{Saved})(Hr)$$



### Install VSD on Chiller

The installation of a VSD on a chiller will improve the efficiency of the chiller especially at part loads. The methodology is very similar to the chiller retrofit. We assume that there is some excess capacity in the chiller system during peak periods and demand savings will be realized.

$$kW_{Saved} = (\eta_{Exist} - \eta_{VSD})(T_{Peak})$$

Energy savings have been estimated with a load bin analysis with a typical load profile.

$$kWh_{Saved} = \Sigma(kW_{Saved})(Hr)$$

### Cooling Tower Replacement

This measure involves the complete replacement of the cooling tower. Savings are based on an improvement in heat exchanging efficiency and an improvement of the chiller efficiency with a lower condenser water temperature.

$$kW_{Saved} = (\eta_{Exist} - \eta_{Prop})(T_{Peak})$$

$$kWh_{Saved} = (kW_{Saved})(Hr)$$

### Controls and EMS

**Energy Savings Methodologies:** In determining the energy savings associated with a Building Automation System (BAS) or EMS, one must first determine the level of automation. Typically, the BAS controls HVAC systems from a demand perspective (ON/OFF) as well as an energy perspective. The following formulas are representative of the implementation of typical sequences of operation:

Savings = Motor Savings + Heating Savings + Cooling Savings

Motor Savings = Motor Cost<sub>base</sub> – Motor Cost<sub>prop</sub>

For constant volume fans:

$$Motor\ Energy_{base} = \sum_{motor} \frac{motor\ hp \times load\ factor \times 0.746\ kW / bhp \times motor\ op\ hrs_{base}}{\eta_{motor}}$$

$$Motor\ Energy_{prop} = \sum_{motor} \frac{motor\ hp \times load\ factor \times 0.746\ kW / bhp \times motor\ op\ hrs_{prop}}{\eta_{motor}}$$

For VAV fans:

Motor Energy<sub>base</sub>

$$= \sum_{motor} \left( \frac{motor\ hp \times load\ factor \times 0.746\ kW / bhp}{\eta} \right) \times (\% load)^{factor_{base}} \times motor\ op\ hrs_t$$

Motor Energy<sub>prop</sub>

$$= \sum_{motor} \left( \frac{motor\ hp \times load\ factor \times 0.746\ kW / bhp}{\eta} \right) \times (\% load)^{factor_{prop}} \times motor\ op\ hrs_t$$

$$Heat\ Load_{base} = \sum \frac{(1.08 \times mixed\ cfm_{base} \times (temp_{MA_{base}} - temp_{DA_{base}})) \times bin\ hrs_{base}}{\eta_{heating} \times 10^6\ Btu / MMBtu}$$

$$Heat\ Load_{prop} = \sum \frac{(1.08 \times mixed\ cfm_{prop} \times (temp_{MA_{prop}} - temp_{DA_{prop}})) \times bin\ hrs_{prop}}{\eta_{heating} \times 10^6\ Btu / MMBtu}$$

Cooling Savings = Cool Cost<sub>base</sub> + Cool Cost<sub>prop</sub>

Cool Cost = Cool Load<sub>elec</sub> (kWh/year) × Elec Util Rate (\$/kWh)

$$Cool\ Load_{elec\ base} = \sum \frac{(4.5 \times mixed\ cfm_{base} \times (H_{DA_{base}} - H_{MA_{base}}) \times bin\ hrs_{base} \times \eta_{cooling\ elec}}{12,000\ Btu / ton - hr}$$

$$Cool\ Load_{elec\ prop} = \sum \frac{(4.5 \times mixed\ cfm_{prop} \times (H_{DA_{prop}} - H_{MA_{prop}}) \times bin\ hrs_{prop} \times \eta_{cooling\ elec}}{12,000\ Btu / ton - hr}$$

$$mixed\ cfm_{base / prop} = vent\ air\ cfm_{base / prop} + return\ air\ cfm_{base / prop}$$

Where:

Motor hp	=	Horsepower of motor
$\eta_{motor}$	=	Efficiency of motor from manufacturer published data and verified during the pre-installation inspection
% load	=	Ratio of the flow in the current bin to the full load capability of the fan or pump
factor <sub>base/prop</sub>	=	Affinity law relationship between flow and power for the pump or fan
vent cfm <sub>base</sub>	=	Existing ventilation cfm
vent cfm <sub>prop</sub>	=	Proposed ventilation cfm (reduced for some AHUs)
temp <sub>DA</sub>	=	Discharge air temperature
temp <sub>MA</sub>	=	Temperature of mixed air in temperature bin
H <sub>DA</sub>	=	Discharge air enthalpy
H <sub>MA</sub>	=	Enthalpy of mixed air in temperature bin
$\eta_{heating}$	=	Efficiency of heating equipment
$\eta_{cooling}$	=	Efficiency of cooling equipment, kW/ton for electric cooling

### Compressed Air

**End Use Description:** This measure involves a modification of the compressed air system at the facility. Typical measures include installing more efficient equipment, reducing the operating pressure, and/or reducing facility plant air needs.

The end-use can be broken into the two separate systems, supply-side and demand-side. The supply side typically consists of an air compressor, air dryer (for moisture sensitive products and lines), and a storage tank. The three basic types of compressors are rotary screw, reciprocating, and centrifugal.

Additionally, the type of control can vary. These include: 1) inlet modulation with unloading; 2) inlet modulation without unloading; 3) load/unload; and 4) on/off. The higher the output pressure, the more work is required by the compressor to deliver the required flow (scfm) to the facility. Thus, the operating pressure will affect the energy consumption of the system. All these factors will result in a different overall efficiency (kW/scfm).

Also, examination of the uses for compressed air could lead to measures to reduce compressed air consumption. Some of these include, using blowers rather than compressed air when high pressure air is not necessary, replacing nozzles, using pressure sensors rather than timed intervals to only purge when necessary, and using water mists to cool hot products rather than compressed air.

**Energy Efficiency Measures:** There are many potential measures associated with the air compressor end-use. However, the measure can be broken down into four distinct categories. These include:

- **Air Compressor Replacement:** A minimum efficiency baseline adjustment may apply depending on the efficiency of the existing equipment.

- **Air Compressor Controls:** This applies to multiple compressor systems and will optimize the operation of the system to operate the most efficient compressor at a given time.
- **Air Compressor Pressure Reduction:** A general rule of thumb is that energy consumption is reduced 1% for every 2 psig of pressure reduction. However, a larger storage-tank volume may be needed to effectively reduce the compressor discharge pressure.
- **Reduction of Air Demand:** Several methods may be used to reduce the air demand of the plant. One of these is the replacement of existing nozzles with nozzles that require less air (such as venturi nozzles), and also to resize the nozzles for the specific application. Another is to use a blower for low pressure applications rather than high pressure compressed air. If air pressure regulators do not exist in the plant, the installation of individual machine pressure regulators will reduce the air demand for the system. And, finally, a leak management program should always be instituted and maintained.

**Baseline Calculation:** The power demand of an air compressor is dependent on the air requirements at the facility. The requirements can fluctuate drastically throughout the day. Thus, the facility's air profile is typically estimated through short-term monitoring of the true RMS kW of the air compressors at the facility. The preferred method is to calculate the annual power demand and energy consumption is with the DOE AirMaster+ software. These programs require an hourly demand profile in power (kW) or flow (scfm). Alternatively, the consumption can be calculated with the manufacturer's specifications and engineering equations.

Industry standard efficiencies exist for typical compressor and control types. Baseline adjustments only apply to air compressor retrofits when the equipment is replaced. Since other components within the compressed air system are modified when the operating compressor size is reduced, baseline adjustments do not apply.

The baseline AirMaster+ model is used as a basis for the retrofit power demand (kW) and energy (kWh) consumption. The load profile will be modified based on the amount of air reduced through energy efficiency efforts. Parameters such as orifice diameter, pressure and volumetric flow can be used to calculate the reduction in air.

**Retrofit Calculations:** For measures that will install equipment to replace the compressor (e.g., replacing with a blower), the power demand of the blower will be accounted for with the following equation:

$$kW_B = 0.746 \left( \frac{HP}{\eta} \right) (LF)$$

Where:

$kW_B$	=	Power demand of retrofit blower motor (kW)
hp	=	Horsepower rating of the retrofit blower motor from nameplate
$\eta$	=	Efficiency of retrofit blower motor
LF	=	Load factor (ratio of actual shaft hp vs. rated hp)
0.746	=	Conversion factor (hp to kW)

$$kWh_B = kW_B (OH)$$

Where:

$kWh_B$	=	Annual energy consumption of the retrofit blower (kWh)
OH	=	Annual operating hours of the blower (hr)

**Demand Reduction:** The demand on the air compressors is permanently reduced and is not weather dependent. Thus, power demand (kW) savings will be achieved. The total demand saved would be determined by the subtracting the demand of any auxiliary equipment added as part of the retrofit from the electricity demand saved by the air compressors. The air compressor demands are based on engineering calculations or outputs from the AirMaster+ modeling software.

**Energy Savings:** Energy savings are the Baseline energy consumption minus the Retrofit consumption. The net energy savings results from subtracting the consumption of the auxiliary equipment installed from the energy consumption outputs from the AirMaster+ model.

**Load Shape:** Trended data is used to establish the load shape. This is input into AirMaster+ model or an equivalent calculation methodology and is used as a basis for the retrofit power demand (kW) and energy (kWh) consumption. The load profile will be modified based on the amount of air reduced through energy efficiency efforts. Manufacturer specifications can be used in the case of the replacement of nozzles or demand side equipment.

**Measure Cost:** The measure cost will include the cost of the installation of the demand reducing equipment and any other modifications that may be required to the system to ensure the process is not affected with the retrofit.

### Compressed Air Pressure Reduction

This measure involves the installation of equipment to allow for the reduction in the discharge. This equipment could be additional storage for the compressed air system or equipment within the system to reduce the overall pressure drop. The rule of thumb is that for every two psi reduction the energy consumption is reduced by 1%.

$$kW_{Saved} \cong (kW_{Exist}) \left( \frac{1\%}{2\text{psi}} \right) (P)$$

The demand reduction will occur at all times the system operates. Thus, the kWh energy savings are:

$$kWh_{Saved} = (kW_{Saved})(Hr)$$

### Compressed Air System Controls

This measure involves the installation of controls to optimize the operation air compressors in systems with multiple machines. These control systems have the ability to trend data and continue to monitor the demand to ensure that the most efficient compressor is being utilized at any one time. Additionally, the system will help to manage correct system pressure automatically. The existing compressor system must be monitored for a representative period of time and analyzed to completely understand the air demand on the system. Each distinct period of existing operation ( $\Sigma kW_{Exist-i}$ ) is analyzed to determine the optimum operating sequence ( $\Sigma kW_{Post-i}$ ).

$$kW_{Saved} = \Sigma kW_{Exist-i} - \Sigma kW_{Post-i}$$

$$kWh_{Saved} = \Sigma [(kW_{Exist-i})(Hr_i)] - \Sigma [(kW_{Post-i})(Hr_i)]$$

### Air Compressor Replacement

This measure involves the replacement of an existing air compressor with a more efficient model. In many instances, the retrofit model will be controlled with a variable speed drive. As we expect the air compressor package power (kW/100 cfm) to vary as a function of load, a complete understanding of the system air profile is necessary to estimate the energy savings potential. Since the air compressor's

energy consumption is typically not driven by outdoor air temperature, a weighted average of hours at each specific air demand can be used to estimate the expected peak kW reduction.

$$kW_{Saved} = \frac{\sum[(PP_{Exist-i} - PP_{Ret-i})(CFM_i)(Hr_i)]}{Hr_{Total}}$$

$$kWh_{Save} = \sum[(PP_{Exist-i} - PP_{Ret-i})(CFM_i)(Hr_i)]$$

### Compressed Air Demand Side Retrofit

Several methods may be used to reduce the air demand of the plant. One of these is the replacement of nozzles that require less air, such as venturi nozzles, and also to resize the nozzles for the specific application. Another is to use a blower for low pressure applications rather than high pressure compressed air. If regulators do not exist in the plant, the installation of individual machine pressure regulators will reduce the air demand for the system. And, finally, a leak management program should always be instituted and maintained.

The average reduction in air use ( $CFM_{Red}$ ) through the installation of equipment is a permanent reduction in energy use. The estimated energy savings relates to the expected air profile after the installation. A complete understanding of the system air profile is necessary to estimate the energy savings potential.

$$kW_{Saved} = \sum(PP_{Exist-i})(CFM_{Exist}) - (PP_{Ret-i})(CFM_{Exist} - CFM_{Red})$$

$$kWh_{Save} = \sum[(PP_{Exist-i} - PP_{Ret-i})(CFM_i)(Hr_i)]$$

### VSD - Centrifugal Pumps

The measure involves installing a VSD on a centrifugal pump. This measure slows the speed of the pump motor to only supply the necessary fluid to meet the demand of the system. The energy consumption of the system is reduced when the flow of the system is reduced.

**Baseline Power Demand and Energy Consumption:** The baseline power demand (kW) is typically constant during operation. This value would be determined with standard engineering equations or a spot measurement. In the case of the calculated approach, the general engineering equation is:

$$kW_{Base} = 0.746 \left( \frac{HP}{\eta} \right) (LF)$$

Where:

$kW_{Base}$	=	Demand of existing motor
hp	=	Horsepower rating of the existing motor from nameplate
$\eta$	=	Efficiency of existing motor or NEMA efficiency if motor is replaced
LF	=	Load factor (ratio of actual shaft hp vs. rated hp)
0.746	=	Conversion factor (hp to kW)

This demand is then multiplied by the annual operating hours (OH) of the motor to estimate the baseline annual energy consumption (kWh). The operating hours may be determined through short-term, run-time monitoring, examination of historical records, or interviews with facility personnel.

$$kWh_{Base} = kW_{Base} (OH)$$

**Baseline Adjustments:** In general, baseline adjustments do not apply with this measure. There are instances when the Customer may replace the existing motor with a Premium Efficiency motor at the same time the VSD is installed. In the event that the existing motor's efficiency is less than the National Electrical Manufacturers Association (NEMA) standard, the baseline will be adjusted to reflect the NEMA Standard Efficiency.

**Retrofit Power Demand and Energy Consumption:** The VSD will control the speed of the motor to match the desired flow profile of the system. A centrifugal pump follows the affinity laws relating the flow directly proportional to the speed and power and speed by the theoretical cube root. However, in practice, inefficiencies exist and this relationship is typically 2.5.

$$kW_2 = kW_1 \left( \frac{n_2}{n_1} \right)^{2.5}$$

Where:

$kW_1$	=	Known energy demand (kW), typically at 100% speed or flow
$kW_2$	=	Energy demand (kW) at different speed, $n_2$
$n_1$	=	Speed at condition 1, expressed as a percent
$n_2$	=	Speed at condition 2, expressed as a percent

VSD's exhibit energy and power losses of approximately 2% in larger motors and 5% in smaller motors. Therefore, the VSD controlled 100% flow is typically, less efficient than the baseline condition. Any operation in this region will result in negative savings.

The operating load profile in the retrofit system will vary depending on the application. A pump is almost always weather dependent if it is used for space conditioning. However, a process pump profile may be based on the production rate at the facility. The determination of an accurate assessment for the retrofit operating profile is critical to the retrofit consumption. This activity may include a load analysis, examination of historical weather data, data logging, and/or interviews with facility personnel. The retrofit energy consumption follows as the sum of the energy consumptions in each flow region.

**Demand and Energy Savings:** Demand savings result when the power (kW) of the system is reduced during the summer peak period. Demand savings will be present in many VSD pumping applications. The system is investigated to estimate the highest possible retrofit demand during the peak period. This value is subtracted from the baseline kW to estimate the demand savings. Demand savings typically do not exist for space conditioning applications. The energy savings are calculated by subtracting the retrofit consumption from the baseline.

### VSD – Ventilation Fan

The measure involves installing a VSD on a ventilation fan. This measure slows the speed of the fan motor to only supply the necessary air flow to meet the demand of the system. The energy consumption of the system is reduced when the flow of the system is reduced.

**Baseline Power Demand and Energy Consumption:** If there is not a mechanism, such as guide vanes or dampers, to restrict the fan flow, the baseline kW demand will be constant for this measure. This value would be determined with standard engineering equations or a spot measurement. In the case of the calculated approach, the general engineering equation is:

$$kW_{Base} = 0.746 \left( \frac{HP}{\eta} \right) (LF)$$

Where:

kW <sub>Base</sub>	=	Demand of existing motor
hp	=	Horsepower rating of the existing motor from nameplate
η	=	Efficiency of existing motor or NEMA efficiency if motor is replaced
LF	=	Load factor (ratio of actual shaft hp vs. rated hp)
0.746	=	Conversion factor (hp to kW)

This demand is then multiplied by the annual operating hours (OH) of the motor to estimate the baseline energy consumption (kWh). The operating hours may be determined through short-term, run-time monitoring, examination of historical records, or interviews with facility personnel.

$$kWh_{Base} = kW_{Base} (OH)$$

If guide vanes or dampers exist to restrict the flow, the demand at different flow regions will vary. In this case, ASHRAE fan curves will be used to determine the demand in each flow region.

The operating profile of the fan is critical to achieving an accurate assessment of the baseline consumption. A ventilation fan is almost always weather dependent if it is used for space conditioning. However, a process oriented fan profile may be based on the production rate of the facility. This activity may include a load analysis, examination of historical weather data, data logging, and/or interviews with facility personnel.

**Baseline Adjustments:** In general, baseline adjustments do not apply with this measure. There are instances when the Customer may replace the existing motor with a Premium Efficiency motor at the same time the VSD is installed. In the event that the existing motor's efficiency is less than the NEMA standard, the baseline will be adjusted to reflect the NEMA Standard Efficiency.

**Retrofit Power Demand and Energy Consumption:** The VSD will control the speed of the motor to match the desired air flow requirements of the ventilation system. A centrifugal fan follows the affinity laws relating the flow directly proportional to the speed and power and speed by the theoretical cube root. However, in practice, inefficiencies exist and this relationship is typically 2.5.

$$kW_2 = kW_1 \left( \frac{n_2}{n_1} \right)^{2.5}$$

Where:

$kW_1$	=	Known energy demand (kW), typically at 100% speed or flow
$kW_2$	=	Energy demand (kW) at different speed, $n_2$
$n_1$	=	Speed at condition 1, expressed as a percent
$n_2$	=	Speed at condition 2, expressed as a percent

VSD's exhibit energy and power losses of approximately 2% in larger motors, and 5% in smaller ones. Therefore, the VSD controlled 100% flow is typically, less efficient than the baseline condition. Any operation in this region will result in negative savings.

If a mechanism to restrict the air flow did not exist in the baseline case, the operating hours flow profile will be determined in the same manner as described above. If a mechanism was present, the retrofit profile is typically identical to the baseline.

The retrofit energy consumption follows as the sum of the energy consumptions in each flow region.

**Demand and Energy Savings:** Demand savings result when the power (kW) of the system is reduced during the summer peak period. Demand savings will be present in many VSD ventilation applications. The system is investigated to estimate the highest possible retrofit demand during the peak period. This value is subtracted from the baseline kW to estimate the demand savings. Demand savings typically do not exist for space conditioning applications.

The energy savings is calculated by subtracting the retrofit consumption from the baseline.

### Generic Process Upgrades

The majority of the energy consumption and energy efficiency opportunities in industrial facilities exist within the actual production process. This end use consists of specific equipment used in the production lines at a facility and are varied depending on the applications ranging from production equipment to heat rejection equipment such as cooling towers.

**Energy Efficiency Measures:** There are countless measures associated with this end use depending on the specific process and facility involved. This section discusses generic process improvements that apply to a large number of industrial facilities.

**Facility Process Improvement:** A facility process improvement involves a measure that reduces the overall production efficiency (kWh/unit produced). This will account for a retrofit that will allow for an increase in production with the same or increased energy use, but results in a net reduction in kWh/unit



production. In this instance, the difference in the overall plant or system production efficiency determines the energy savings.

**Process Cooling Tower Upgrade:** This energy efficiency measure involves upgrading the existing inefficient cooling towers with energy efficient systems that have improved heat transfer enhancement.

**Hydraulic Process Improvement:** A retrofit to a hydraulic pump and motor system can reduce energy consumption during the clamp period of the cycle.

### Facility Process Improvement

This measure will pay incentives for the installation of new, high-efficiency equipment to meet the expanded process needs of an existing facility or to accommodate new production loads. Projects that involve modifying an existing operation, structure or process due to growth or expansion will also be included under this measure.

In general, the calculation methodology is the same for the specific process improvements. The calculation involves the difference in production efficiency (kW/unit, kWh/unit). The incentives for retrofit measures with increased capacity will be based on the post-installation production. In general, the following equations apply:

$$kW_{Saved} = \left[ \left( \frac{kW_{Exist}}{Unit_{Exist}} \right) - \left( \frac{kW_{Ret}}{Unit_{Ret}} \right) \right] (Unit_{Ret})$$

$$kWh_{Saved} = \left[ \left( \frac{kWh_{Exist}}{Unit_{Exist}} \right) - \left( \frac{kWh_{Ret}}{Unit_{Ret}} \right) \right] (Unit_{Ret})$$

### Process Cooling Tower Upgrade

This measure involves the upgrades of the cooling tower used to cool equipment in the process or the product. Savings are based on an improvement in heat exchanging efficiency and an improvement of the chiller efficiency, if applicable, with a lower condenser water temperature.

$$kW_{Saved} = (\eta_{Exist} - \eta_{Prop})(T_{Peak})$$

$$kWh_{Saved} = (kW_{Saved})(Hr)$$

### Hydraulic Process Improvement

A hydraulic system uses significant energy to maintain pressure throughout the entire cycle. Additionally, the hydraulic fluid must be cooled. Often times, this is done by mechanical cooling. A retrofit to a hydraulic pump and motor system can reduce the energy consumption during specific periods of the cycle. This specifically occurs during the clamp period of the cycle. A torque controlled servo motor can maintain the pressure of the fluid during clamp and hold periods at almost no power consumption. The speed of the shaft is constantly monitored to maintain the pressure in the system. Additionally, the requirement for hydraulic fluid cooling is eliminated. Monitoring of the system must be performed to completely understand the cycle and when the system can save energy.

$$kW_{Saved} = kW_{Ave-Exist-Cycle} - kW_{Ave-Ret-Cycle}$$

$$kWh_{Saved} = \sum kW_{Saved-period-i} (Hr_{Period-i})$$

### All Other

New and/or emerging technologies, as well as non-evaluated measures, will be evaluated by Program Engineers using commonly accepted engineering practices. These evaluations will be subject to review and approval by Ameren Missouri prior to issuance of a custom incentive offer. Following project completion the measure may be subject to EM&V review to confirm the results of the project.

Upon determination that the measure should be evaluated for inclusion in the TRM, the process as outlined in the section entitled “Protocol for Deeming Measures Not Found Within TRM” shall be employed and the measure treated accordingly.

## Building Simulation Protocols<sup>10</sup>

### Introduction

This report presents the results of an engineering study of common residential and commercial buildings retrofit measures analyzed in support of creating a statewide retrofit measure savings database for Ameren Business and Corporate Services. These per unit energy savings estimates will be used to guide program design and cost effectiveness calculations for Ameren Business and Corporate Services energy efficiency programs. The measures and analysis techniques are described in the following sections and are applicable to those measures within this TRM being derived from the Morgan Measure Database (MMD).

A set of residential and commercial prototypical building models was developed using the DOE-2.2 building energy simulation program for each of the market segments defined. The prototypes are based on the models used in the California Database for Energy Efficiency Resources (DEER) study, with appropriate modifications to adapt these models to local design practices and climate.

For the residential sector, prototype models for single family detached, multifamily and manufactured homes were developed. Prototype models for small commercial buildings were developed for small retail, big-box retail, small office, fast food restaurant, full service restaurant, school, assembly, warehouse, grocery and light industrial buildings. Large commercial building prototypes for large office, hospital, and hotel building types were also developed.

The HVAC measures for residential buildings include split system central air conditioners, air source heat pumps and dual fuel heat pumps, condensing gas furnaces with and without EC motors, and ground source heat pumps. Setback thermostats, duct insulation and leakage sealing, and refrigerant charge correction measures were also analyzed. Shell measures include roof, wall, floor, crawlspace and basement insulation upgrades, high-performance glazing, and air leakage sealing. Whole house fans and efficient ceiling fans were also analyzed.

The HVAC measures for small commercial buildings include single package rooftop air conditioners and heat pumps, split system air conditioners and heat pumps, packaged terminal air conditioners and heat pumps, and water loop heat pumps. Setback thermostats, air side economizers, and refrigerant charge correction measures were also analyzed. HVAC measures for large commercial buildings include air cooled and water cooled chillers, chilled water setback control, and variable frequency drives on fans and pumps. Shell measures include window films, high-performance glazing, and cool roofs. Refrigeration

---

<sup>10</sup> Developed for Ameren Missouri by Architectural Energy Corporation on behalf of Morgan Marketing Partners. September 2009.

measures include anti-sweat heater controls, case night covers, floating head pressure control and high-efficiency condensers.

Energy savings estimates were developed from the prototype models. The results of these simulations were compiled into a database containing measure savings and measure costs by building type and climate zone. The database was delivered in an Excel spreadsheet format. Population weights for climate zone, building type and vintage can be applied to compile weighted savings across all building types, vintages and climate zones of interest to the IOUs.

### **Residential Building Prototype Model Development**

Residential sector models of single family detached “stick-built” and manufactured homes along the two sizes of multifamily homes were developed. The description of the single family, manufactured home and multifamily prototypes follows.

#### ***Single Family Homes***

Residential sector models of single family detached “stick-built” and manufactured homes were developed. The description of the single family and manufacture home prototypes follows.

This analysis is based on DOE-2.2 simulations of a set of prototypical single family residential buildings. The prototypical simulation models were derived from the residential building prototypes used in the California DEER study, with adjustments make for local building practices and climate. The prototype “model” in fact contains 4 separate residential buildings; 2 one-story and 2 two-story buildings. Each version of the 1 story and 2 story buildings are identical except for the orientation, which is shifted by 90 degrees. The selection of these 4 buildings is designed to give a reasonable average response of buildings of different design and orientation to the impact of energy efficiency measures.

Three separate models were created to represent general vintages of buildings:

- Old, poorly insulated building constructed in the 1950s or earlier. This vintage is referred to as the “old” vintage
- Existing, average insulated building conforming to 1980s era building codes. This vintage is referred to as the “average” vintage.
- New construction conforming to the IECC 2004. This vintage is referred to as the “new” vintage.

A sketch of the residential prototype buildings is shown in Figure 1.

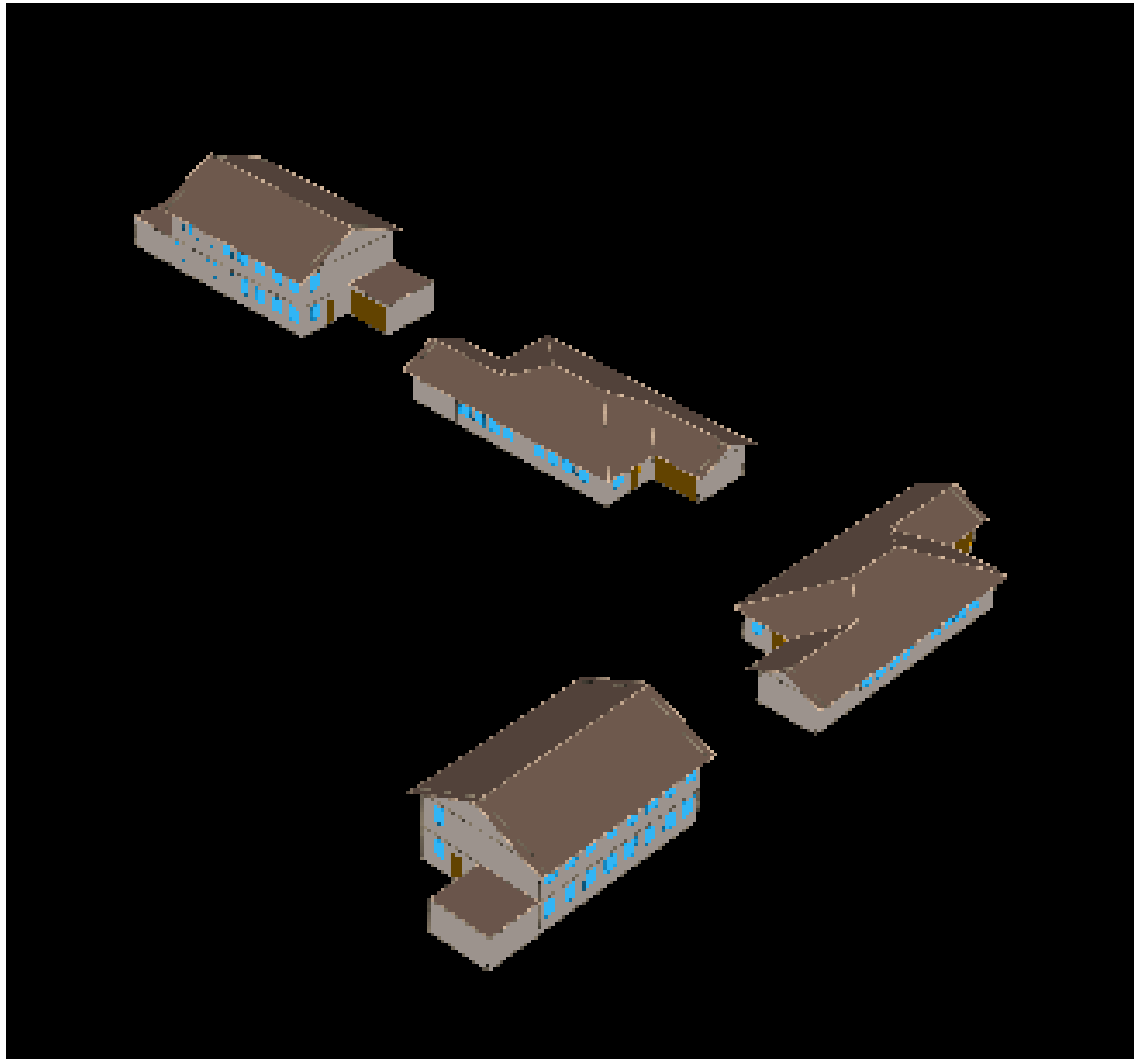

**Figure 1. Computer rendering of residential building prototypical DOE-2 model.**

The base prototype includes an unconditioned basement. The general characteristics of the residential building prototype model are summarized in Table 1.

**Table 1. Residential Building Prototype Description**

Characteristic	Value
Vintage	Three vintages simulated – old poorly insulated buildings, existing average insulated buildings and new buildings
Conditioned floor area	1 story house: 1465 SF (not including basement) 2 story house: 2930 SF (not including basement)
Wall construction and R-value	Wood frame with siding, R-value varies by vintage
Roof construction and R-value	Wood frame with asphalt shingles, R-value varies by vintage
Glazing type	Average of single and double pane; properties vary by vintage
Lighting and appliance power density	0.51 W/SF average

Characteristic	Value
HVAC system type	Central split system AC with gas furnace Central split system heat pump Electric furnace only Gas furnace only
HVAC system size	Based on ASHRAE design day peak load with 20% oversizing.
HVAC system efficiency	Baseline SEER = 13
Thermostat setpoints	Heating: 70°F with setback to 60°F Cooling: 75°F with setup to 80°F
Duct location	Buildings without basement: attic Buildings with basement: basement
Duct surface area	Single story house: 390 SF supply, 72 SF return Two story house: 505 SF supply, 290 SF return
Duct insulation	Uninsulated
Duct leakage	20% of fan flow total leakage, evenly split between supply and return.
Natural ventilation	Allowed during cooling season when cooling setpoint exceeded and outdoor temperature < 65°F. 2 air changes per hour

### Wall, Floor and Ceiling Insulation Levels

The assumed insulation R-values for wall, floor and ceiling insulation by vintage are shown in Table 2 through Table 4.

**Table 2. Wall Insulation R-Value Assumptions by Vintage**

Vintage	Assumed R-value of insulated wall	Notes
Older, poorly insulated	7	Wood frame 2x4 with wood siding, drywall, no insulation
Existing, average insulation	11	Fiberglass insulation in 2 by 4 wall per MEC 1980
New construction	St Louis - 15	IECC 2004

**Table 3. Floor Insulation Levels by Vintage**

Vintage	Assumed R-value of insulated wall	Notes
Older, poorly insulated	2	12" concrete block, no insulation
Existing, average insulation	6	12" concrete block, 1" expanded polystyrene
New construction	St Louis - 21	IECC 2004

**Table 4. Ceiling Insulation R-Value Assumptions by Vintage**

Vintage	Assumed R-value of insulated ceiling	Notes
Older, poorly insulated	11	Minimal ceiling insulation
Existing, average insulation	19	Fiberglass insulation per MEC 1980
New construction	St Louis - 38	IECC 2004

### Windows

The glazing U-value and solar heat gain coefficient (SHGC) assumptions for the three vintages are shown in Table 5.

**Table 5. Window Property Assumptions by Vintage**

Vintage	U-value (Btu/hr-F-SF)	SHGC	Notes
Older, poorly insulated	0.93	0.87	Single pane clear
Existing, average insulation	0.68	0.77	Avg. of Double Pane 1/2" air space (U=0.49) and standard double pane (U=0.87)
New construction	0.35	St Louis – 0.40	IECC 2004

### Infiltration

Infiltration rate assumptions were set by vintage as shown in Table 6.

**Table 6. Infiltration Rate Assumptions by Vintage**

Vintage	Assumed infiltration rate	Notes
Older, poorly insulated	1 ACH	
Existing, average insulation	0.5 ACH	
New construction	0.35 ACH	Minimum without forced ventilation per ASHRAE Standard 66.

### Manufactured Homes

This analysis is based on DOE-2.2 simulations of a set of prototypical manufactured homes. The prototypical simulation models were derived from the manufactured home prototypes used in the California DEER study, with adjustments made for local building practices and climate. The prototype “model” in fact contains 2 separate buildings; each version is identical except for the orientation, which is shifted by 90 degrees. The selection of these 2 buildings is designed to give a reasonable average

response of buildings of different orientations to the impact of energy efficiency measures. A computer rendering of the manufactured home DOE-2 prototype model is shown in Figure 2.

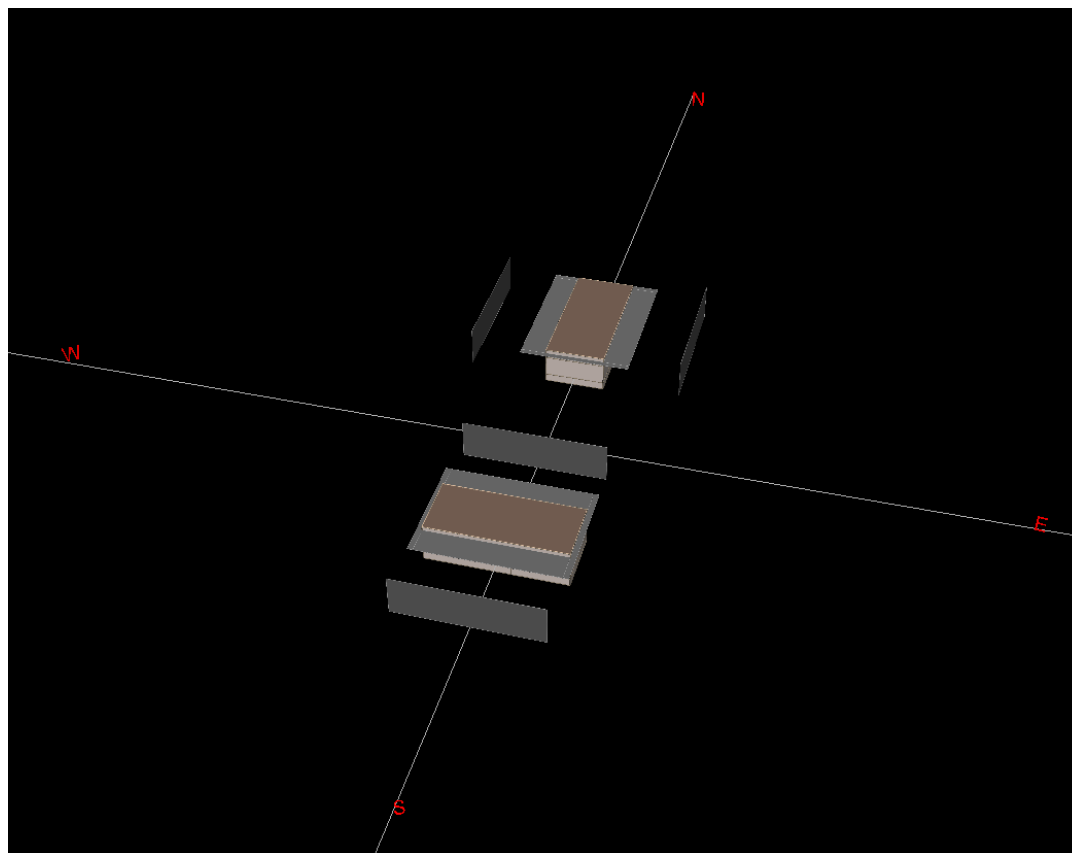

**Figure 2. Computer rendering of manufactured home prototypical DOE-2 model.**

Manufactured homes built before 1976 were constructed to much lower standards than those built later. Homes built prior to 1976 had only one or two inches of insulation wrapped around the walls, floor and ceiling, 2" x 2" or 2" x 3" studs, uninsulated air ducts, no ceiling vapor barrier, and jalousie windows. Manufactured homes manufactured in 1976 or later were built to much higher standards required by the HUD (US Government Dept. of Housing and Urban Development). An overall description of the manufactured home prototype model is shown in Table .

**Table 7. Manufactured Home Prototype Building Description**

Characteristic	Value
Vintage	Three vintages simulated – Pre 78, 78-95, and 95-05.
Conditioned floor area	1196 SF (23 x 52)
Wall construction and R-value	Wood frame, R-value varies by vintage
Roof construction and R-value	Wood frame, R-value varies by vintage
Glazing type	Single or double pane, varies by vintage. 191 SF (16% of floor area)
Lighting and appliance power density	0.58 W/SF



Characteristic	Value
HVAC system types	Central split system AC with gas furnace Central split system AC with electric furnace Central split system heat pump Central dual fuel heat pump Electric furnace only Gas furnace only
HVAC system size	Based on ASHRAE design day peak load with 20% oversizing.
HVAC system efficiency	Baseline SEER = 13
Thermostat setpoints	Heating: 70°F with setback to 60°F Cooling: 75°F with setup to 80°F
Duct location	Attic
Duct surface area	360 SF (supply only)
Duct insulation	Uninsulated
Duct leakage	22.5% of fan flow total leakage, evenly split between supply and return.
Natural ventilation	Allowed during cooling season when cooling setpoint exceeded and outdoor temperature < 65°F. 2 air changes per hour

### Wall, Floor and Ceiling Insulation Levels

The assumed values for wall and ceiling by vintage are shown in Table .

**Table 8. Wall Floor and Ceiling Insulation R-Value Assumptions by Vintage**

Vintage	R-value of insulated wall	R-value of insulated floor	R-value of insulated ceiling
Pre 78	5.0	5.0	5.0
78 - 94	8.0	8.0	8.0
95 - 05	13.0	13.0	13.0

### Windows

The glazing U-value and solar heat gain coefficient (SHGC) assumptions for the three vintages are shown in Table .

**Table 9. Window Property Assumptions by Vintage**

Vintage	U-value (Btu/hr-F-SF)	SHGC
Pre 78	1.27	0.87
78 - 94	0.87	0.77
95 - 05	0.65	0.56

### Infiltration

Infiltration rate assumptions were set by vintage as shown in Table .

**Table 10. Infiltration Rate Assumptions by Vintage**

Vintage	Assumed infiltration rate
Pre 78	1 ACH
78 - 94	0.5 ACH
95 - 05	0.35 ACH

### Multifamily

Analysis used to develop parameters for the energy and demand savings calculations are based on DOE-2.2 simulations of a set of prototypical multifamily buildings. The prototypical simulation models were derived from the multifamily residential building prototypes used in the California DEER<sup>11</sup> study, with adjustments made for local building practices and climate.

Prototypes were developed for the multi-family 2-4 unit and the multi-family 5+ unit sections. The multifamily 2-4 unit building is a four unit building, with 2 units on each of 2 floors. The multi-family 5+ unit building is a 12 unit building, with 6 units on each of two floors.

The low-rise prototype “models” in fact contains 2 separate buildings. Each version of the building is identical except for the orientation, which is shifted by 90 degrees. The selection of these 2 orientations is designed to give a reasonable average response of buildings of different design and orientation to the impact of energy efficiency measures.

Three separate models were created to represent general vintages of buildings:

- Old: Poorly insulated building constructed in the 1950s or earlier. This vintage is referred to as the “old” vintage
- Existing: Average insulated building conforming to 1980s era building codes. This vintage is referred to as the “average” vintage.
- New: Construction conforming to the current state energy standards for residential buildings. This vintage is referred to as the “new” vintage.

Each building was run with up to 7 different HVAC system types to capture the range of HVAC systems common in low-rise multifamily buildings. A sketch of the low-rise 5+ unit prototype is shown in Figure 3 below.

<sup>11</sup> 2004-2005 Database for Energy Efficiency Resources (DEER) Update Study, Final Report, Itron, Inc. Vancouver, WA. December, 2005. Available at [http://www.calmac.org/publications/2004-05\\_DEER\\_Update\\_Final\\_Report-Wo.pdf](http://www.calmac.org/publications/2004-05_DEER_Update_Final_Report-Wo.pdf)

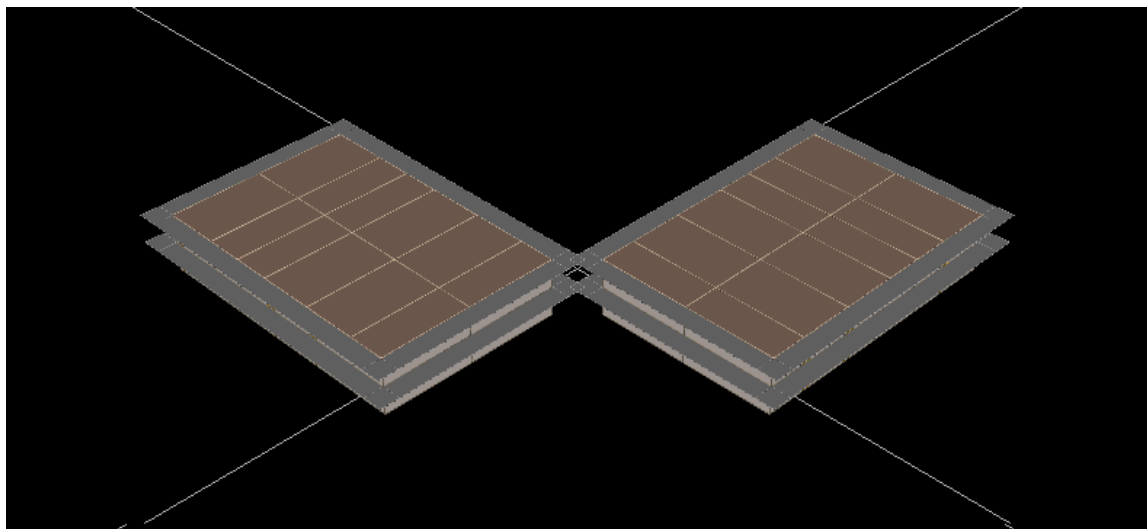

**Figure 3. Low-rise Multifamily 5+ Unit Building**

The general characteristics of the multi-family building prototype model are summarized in Table 12 below:

**Table 11. Multifamily Low-Rise Residential Building Prototype Description**

Characteristic	Value
Vintage	Three vintages simulated – old poorly insulated buildings, existing average insulated buildings and new buildings
Conditioned floor area	<b>2-4 unit building:</b> 950 SF per unit; 2 units per floor, 2 floors per building, 3,800 SF total <b>5+ unit building:</b> 950 SF per unit; 6 units per floor, 2 floors per building, 11,400 SF total.
Wall construction and R-value	Wood frame with siding, R-value varies by vintage
Roof construction and R-value	Wood frame with asphalt shingles, R-value varies by vintage
Glazing type	Single or double pane; properties vary by vintage
Lighting and appliance power density	0.87 W/SF average in bedrooms, 0.58 W/SF in living space
HVAC system types <sup>12</sup>	Split system AC with gas heat Split system AC with electric heat Split system heat pump PTAC with electric heat PTHP Electric heat only (no AC) Gas heat only (no AC)
HVAC system size	Based on peak load with 20% oversizing.
HVAC system efficiency	AC and heat pump: SEER = 13 PTAC and PTHP: EER = 7.1 (Old and Average) PTAC and PTHP: EER = 8.7 (New) Furnace AFUE = 78

<sup>12</sup> PTAC and PTHP systems simulated for MF 5+ unit building only.

Characteristic	Value
Thermostat setpoints	Heating: 70°F with setback to 67°F Cooling: 75°F with setup to 78°F
Duct location	In attic and plenum space between first and second floors. PTACs and PTHPs have no duct work.
Duct surface area	256 SF supply, 47 SF return per system
Duct insulation	Uninsulated
Duct leakage	20% of fan flow total leakage, evenly split between supply and return.
Natural ventilation	Allowed during cooling season when cooling setpoint exceeded and outdoor temperature < 65°F. 3 air changes per hour

### Wall and Ceiling Insulation Levels

The assumed values for wall and ceiling by vintage are shown in Tables 13-14 below:

**Table 12. Wall Insulation R-Value Assumptions by Vintage**

Vintage	Assumed R-value of insulated wall	Notes
Older, poorly insulated	7	No insulation in 2 by 4 wall; 3.5 in. air gap resistance only
Existing, average insulation	11	Fiberglass insulation in 2 by 4 wall per MEC 1980
New construction	Springfield – 19 St Louis - 15	Code

**Table 13. Ceiling Insulation R-Value Assumptions by Vintage**

Vintage	Assumed R-value of insulated ceiling	Notes
Older, poorly insulated	11	Minimal ceiling insulation
Existing, average insulation	19	Fiberglass insulation per MEC 1980
New construction	38	Code

### Windows

The glazing U-value and solar heat gain coefficient (SHGC) assumptions for the three vintages are shown in Table 15 below.

**Table 14. Window Property Assumptions by Vintage**

Vintage	U-value (Btu/hr-F-SF)	SHGC	Notes
Older, poorly insulated	0.93	0.87	Single pane clear
Existing, average insulation	0.68	0.77	Double pane clear
New construction	0.35	Springfield – 0.55 St Louis – 0.40	Double low e per code

### Infiltration

Infiltration rate assumptions were set by vintage as shown in Table 16 below.

**Table 15. Infiltration Rate Assumptions by Vintage**

Vintage	Assumed infiltration rate	Notes
Older, poorly insulated	1 ACH	
Existing, average insulation	0.5 ACH	
New construction	0.35 ACH	Minimum without forced ventilation per ASHRAE Standard 66.

### Residential Measure Savings Analysis

The prototype models were simulated with a variety of efficiency measures to develop a series of savings estimates. Efficiency measures are discussed in the following sections.

#### Air-Conditioners and Heat Pumps

Air conditioning systems were simulated with a baseline SEER 13 air conditioner and with a series of high efficiency air conditioners ranging from SEER 14 to SEER 17. Heat pump systems were simulated with a baseline SEER 13 heat pump and with a series of high efficiency heat pumps ranging from SEER 14 to SEER 18. Standard heat pumps were simulated with electric resistance backup, while dual fuel heat pumps were simulated with a gas furnace backup.

The basic efficiency assumptions for each of the air conditioner and heat pump measures are shown in Table 17. These data were taken from an extensive study of residential air conditioners and heat pumps conducted for the California DEER update study.<sup>13</sup> Besides these basic efficiency parameters, an extensive set of performance curves were developed representing mean performance of production units in each SEER category. These performance curves describe unit efficiency as a function of outdoor

<sup>13</sup> Itron, 2005. "2004-2005 Database for Energy Efficiency Resources (DEER) Update Study, Final Report," Itron, Inc., J.J. Hirsch and Associates, Synergy Consulting, and Quantum Consulting. December, 2005. Available at <http://eega.cpuc.ca.gov/deer>

temperature, part-load efficiency, fan power, and so on. These curves were also applied to air conditioner and heat pump measures in each SEER category. All air conditioners and heat pumps SEER 14 and higher were assumed to have electronically commutated motors (ECM) and thermostatic expansion valves (TXV).

**Table 16. Baseline and Measure Performance Assumptions for Split Air Conditioners and Heat pumps**

Type	Efficiency	Fan Motor Type	EER	Sensible Heat Ratio	Air flow (CFM/ton)	Heating COP
Air conditioner	SEER 13	Standard	11.09	0.75	376	
	SEER 14	ECM	11.99	0.81	409	
	SEER 15	ECM	12.72	0.81	409	
	SEER 16	ECM	11.61	0.81	409	
	SEER 17	ECM	12.28	0.8	422	
Air Source and Dual Fuel Heat Pump	SEER 13	Standard	11.07	0.725	337	3.28
	SEER 14	ECM	11.72	0.78	400	3.52
	SEER 15	ECM	12.32	0.78	400	3.74
	SEER 16	ECM	12.06	0.78	400	3.48
	SEER 17	ECM	12.52	0.81	430	3.26
	SEER 18	ECM	12.80	0.8	428	3.66

Efficiency assumptions for PTAC and PTHP systems vary by unit size and whether the unit is replacing an existing unit or is a new installation. Typical efficiency values were chosen for a 1.5 ton unit. The baseline and measure efficiencies are shown in Table 17 below:

**Table 17. Baseline and Measure Performance Assumptions for PTACs and PTHPs.**

Type	Vintage	Cooling EER base	Heating COP base	Cooling EER measure	Heating COP measure
PTAC	Existing	7.1		9.3	
	New	8.7		10.3	
PTHP	Existing	7.0	2.4	9.1	3.0
	New	8.5	2.7	10.9	3.4

### Wall Insulation

For single family residential buildings, the “old” vintage model insulation is upgraded to R-13 to fill 2x4 wall construction. The “average” vintage model insulation is upgraded to R-13 and added one inch of rigid foam insulation to the exterior (R-5). The “new” vintage model added rigid foam insulation to the exterior.

For manufactured homes, the Pre 78 vintage model has R-5 insulation in wall, upgraded to R-10. The 78-95 vintage model has R-8 insulation in the wall, upgraded to R-13. The 95-05 vintage model has R-13 insulation in the wall, added rigid foam insulation to the exterior (R-21)

### **Roof Insulation**

For single family residential buildings, the “old” vintage model has R-11 insulation, upgraded to R-30. The “average” vintage model has R-19 insulation, upgraded to R-30. The “new” vintage model roof insulation was upgraded to R-50

For manufactured homes, the Pre 78 vintage model has R-5 insulation in the roof, upgraded to R-10. The 78-95 vintage model has R-8 insulation in the roof, upgraded to R-30. The 95-05 vintage model has R-13 insulation in the roof, upgraded to R-38.

### **Floor Insulation**

Single family homes were modeled above a basement, thus floor insulation was not modeled. For manufactured homes, the Pre 78 vintage model has R-5 insulation in the floor, upgraded to R-10. The 78-95 vintage model has R-8 insulation in the floor, upgraded to R-19. The 95-05 vintage model has R-13 insulation in the floor, upgraded to R-25.

### **Basement Wall Insulation**

For single family residential buildings, the “old” vintage model has R-2 insulation, upgraded to R-19. The “average” vintage model has R-6 insulation, upgraded to R-19. The “new” vintage model has R-15 insulation, upgraded to R-19.

For manufactured homes, the crawlspace walls are simply skirting with no insulation for any vintage. The modeled measure assumes insulation is placed on the skirting in place of insulating the floor. R-19 insulation is assumed for all eras.

### **Replacement Windows**

Window upgrades for single family residential buildings are based on the Energy Star specifications, with a U-value of 0.35 and a SHGC of 0.40. Window upgrades for manufactured homes are based on a high performance system with a U-value of 0.41 and a SHGC of 0.35.

### **Duct Insulation**

Duct insulation was increased from the uninsulated base to R-6. Insulation was assumed to be applied to both supply and return ductwork as applicable.

### **Duct Leakage**

Total duct leakage (supply plus return) is reduced to 6% of the HVAC system air flow at system operating static pressure.

### **HVAC Tune-up**

This measure was modeled by simulating degrading the full-load efficiency of an untreated system in the base case and returning the treated system to its rated efficiency. A series of parametric runs was done to simulate the effect of HVAC tune-ups representing a 5%, 10% and 15% improvement.

### **Setback Thermostat**

Two levels of setback were evaluated. A “moderate” setback case and a “full” setback case. For the moderate case, the heating schedule was changed from 70 degrees F for all 24 hours of the day in the base to 65 degrees from 11 pm to 6 am using a setback thermostat. Cooling schedule was changed from 75 degrees F for all 24 hours of the day in the base to 78 degrees from 11 pm to 6 am with the setback thermostat.

For the full setback case, the heating schedule was changed from 70 degrees F for all 24 hours of the day in the base to 60 degrees from 11 pm to 6 am using a setback thermostat. Cooling schedule was changed from 75 degrees F for all 24 hours of the day in the base to 82 degrees from 11 pm to 6 am with the setback thermostat.

Note: baseline operation of buildings receiving setback thermostats may include some occupant manual setback of room temperature setpoints. This occupant behavioral effect on the baseline energy use is not accounted for in the simulations.

### **EC Motor**

For all EC motor measures, fan control was set to 2 speed operation and the fan power was reduced by 60%. The control of the furnace fan (either cycling with a call for heating or cooling; or continuous operation) was kept constant in the baseline and the EC motor simulations. Note: some occupants may change their operation from “cycling” to continuous operation after upgrading their furnace and/or air conditioner. This occupant behavioral effect on the energy savings is not accounted for in the simulations.

### **Infiltration Reduction**

Two simulations were run for this measure, where the infiltration rate is reduced by 30% and by 50% relative to the baseline infiltration rate, which varies by vintage.

### **Commercial Building Prototype Model Development**

Commercial sector prototype building models were developed for a series of small commercial buildings with packaged rooftop HVAC systems, including assembly, big box retail, fast food restaurant, full service restaurant, grocery, light industrial, primary school, small office and small retail buildings. A large office prototype was also included to analyze measures associated with built-up HVAC systems. The following sections describe the prototypical simulation models used in this analysis.

### **Assembly**

A prototypical building energy simulation model for an assembly building was developed using the DOE-2.2 building energy simulation program. The characteristics of the prototype are summarized in Table 18.

**Table 18. Assembly Prototype Building Description**

Characteristic	Value
Vintage	Existing (1970s) vintage
Size	34,000 square feet Auditorium: 33,240 SF Office: 760 SF
Number of floors	1
Wall construction and R-value	Concrete block, R-5
Roof construction and R-value	Wood frame with built-up roof, R-12
Glazing type	Multipane Shading-coefficient = 0.84 U-value = 0.72
Lighting power density	Auditorium: 1.9 W/SF Office: 1.55 W/SF
Plug load density	Auditorium: 1.2 W/SF Office: 1.7 W/SF
Operating hours	Mon-Sun: 8am – 9pm



Characteristic	Value
HVAC system type	Packaged single zone, no economizer
HVAC system size	Based on ASHRAE design day conditions, 10% oversizing assumed.
Thermostat setpoints	Occupied hours: 75 cooling, 70 heating Unoccupied hours: 80 cooling, 65 heating

A computer-generated sketch of the prototype is shown in Figure 3.

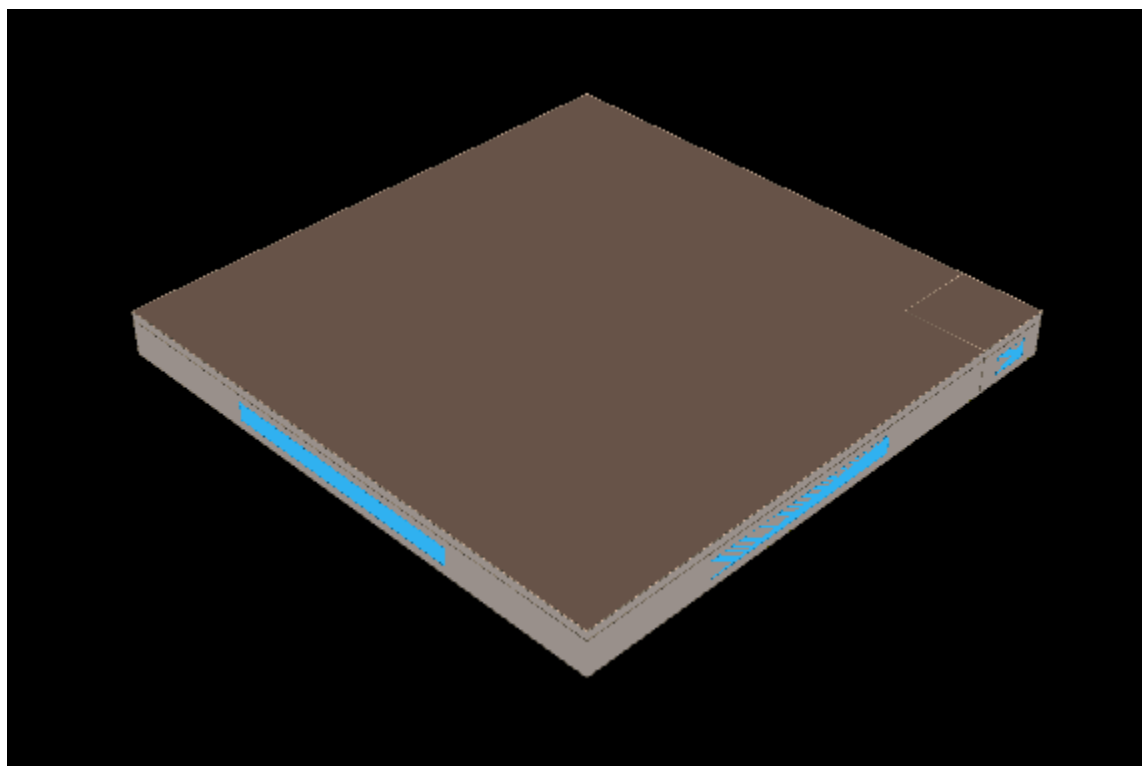

**Figure 3. Assembly Building Rendering**

### **Big Box Retail**

A prototypical building energy simulation model for a big box retail building was developed using the DOE-2.2 building energy simulation program. The characteristics of the prototype are summarized in Table 19.

**Table 19. Big Box Retail Prototype Building Description**

Characteristic	Value
Vintage	Existing (1970s) vintage
Size	130,500 square feet Sales: 107,339 SF Storage: 11,870 SF Office: 4,683 SF Auto repair: 5,151 SF Kitchen: 1,459 SF
Number of floors	1
Wall construction and R-value	Concrete block with insulation, R-7.5

Characteristic	Value
Roof construction and R-value	Metal frame with built-up roof, R-13.5
Glazing type	Multipane; Shading-coefficient = 0.84 U-value = 0.72
Lighting power density	Sales: 2.15 W/SF Storage: 0.85 W/SF (Active) 0.45 W/SF (Inactive) Office: 1.55 W/SF Auto repair: 1.7 W/SF Kitchen: 2.2 W/SF
Plug load density	Sales: 1.15 W/SF Storage: 0.23 W/SF Office: 1.73 W/SF Auto repair: 1.15 W/SF Kitchen: 3.23 W/SF
Operating hours	Mon-Sun: 10am – 9pm
HVAC system type	Packaged single zone, no economizer
HVAC system size	Based on ASHRAE design day conditions, 10% oversizing assumed.
Thermostat setpoints	Occupied hours: 75 cooling, 70 heating Unoccupied hours: 80 cooling, 65 heating

A computer-generated sketch of the prototype is shown in Figure 4.

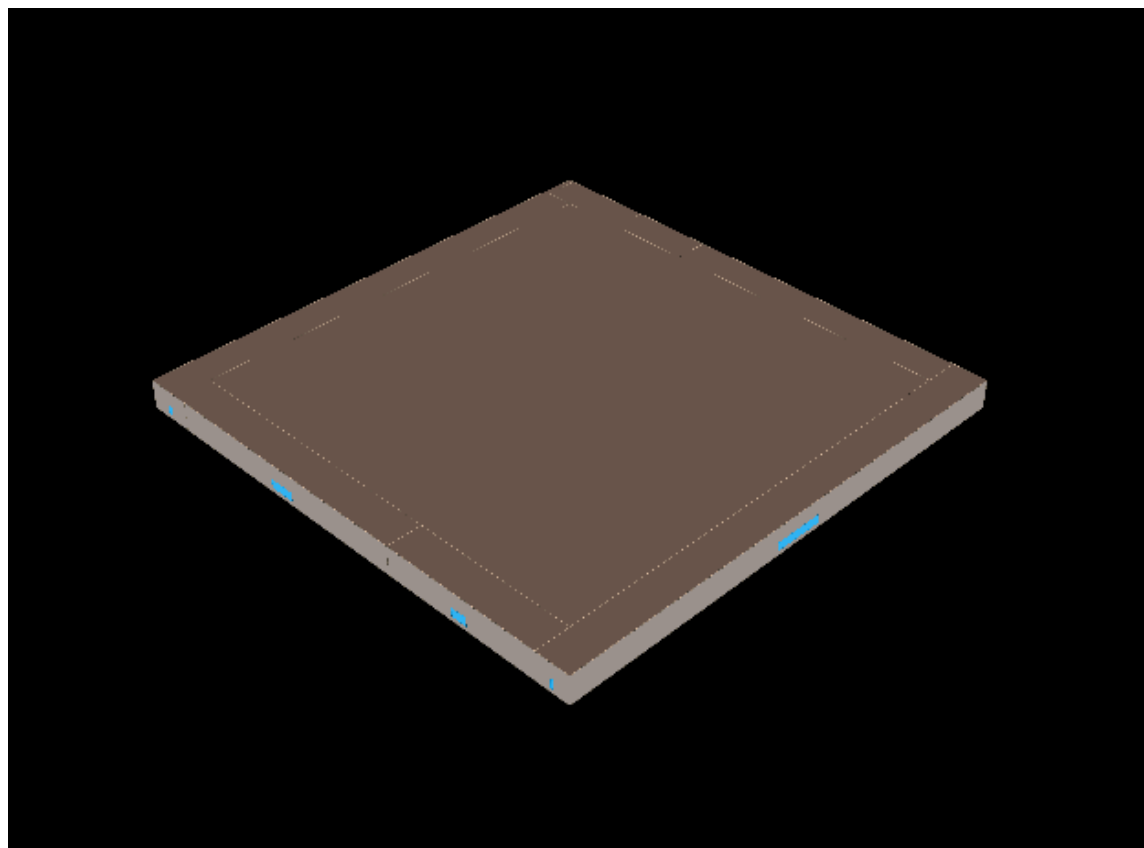

**Figure 4. Big Box Retail Building Rendering****Fast Food Restaurant**

A prototypical building energy simulation model for a fast food restaurant was developed using the DOE-2.2 building energy simulation program. The characteristics of the prototype are summarized in Table 20.

**Table 20. Fast Food Restaurant Prototype Building Description**

Characteristic	Value
Vintage	Existing (1970s) vintage
Size	2000 square feet 1000 SF dining 600 SF entry/lobby 300 SF kitchen 100 SF restroom
Number of floors	1
Wall construction and R-value	Concrete block with brick veneer, R-7.5
Roof construction and R-value	Concrete deck with built-up roof, R-13.5
Glazing type	Multipane Shading-coefficient = 0.84 U-value = 0.72
Lighting power density	Dining: 1.7 W/SF Entry area: 1.7 W/SF Kitchen: 2.2 W/SF Restroom: 0.9 W/SF
Plug load density	0.6 W/SF dining 0.6 W/SF entry/lobby 4.3 W/SF kitchen 0.2 W/SF restroom
Operating hours	Mon-Sun: 6am – 11pm
HVAC system type	Packaged single zone, no economizer
HVAC system size	Based on ASHRAE design day conditions, 10% oversizing assumed.
Thermostat setpoints	Occupied hours: 75 cooling, 70 heating Unoccupied hours: 80 cooling, 65 heating

A computer-generated sketch of the prototype is shown in Figure 5.

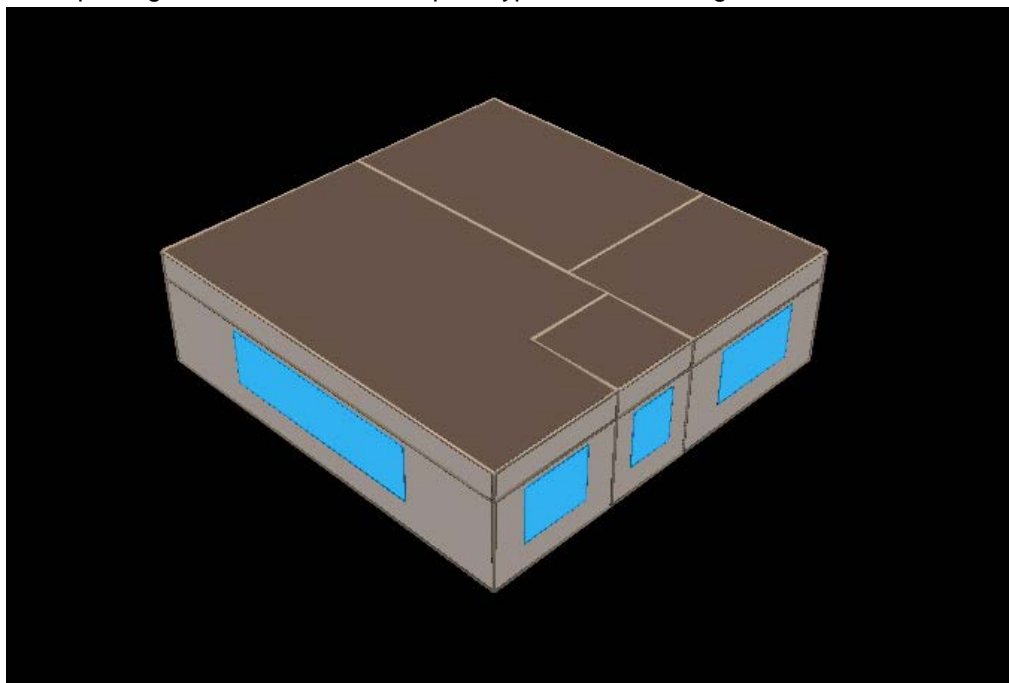

**Figure 5. Fast Food Restaurant Building Rendering**

### **Full-Service Restaurant**

A prototypical building energy simulation model for a full-service restaurant was developed using the DOE-2.2 building energy simulation program. The characteristics of the full service restaurant prototype are summarized in Table 21.

**Table 21. Full Service Restaurant Prototype Description**

Characteristic	Value
Vintage	Existing (1970s) vintage
Size	2000 square foot dining area 600 square foot entry/reception area 1200 square foot kitchen 200 square foot restrooms
Number of floors	1
Wall construction and R-value	Concrete block with brick veneer, R-7.5
Roof construction and R-value	Wood frame with built-up roof, R-13.5
Glazing type	Multipane; Shading-coefficient = 0.84 U-value = 0.72
Lighting power density	Dining area: 1.7 W/SF Entry area: 1.7 W/SF Kitchen: 2.2 W/SF Restrooms: 1.5 W/SF
Plug load density	Dining area: 0.6 W/SF Entry area: 0.6 W/SF Kitchen: 3.1 W/SF Restrooms: 0.2 W/SF

Characteristic	Value
Operating hours	9am – 12am
HVAC system type	Packaged single zone, no economizer
HVAC system size	Based on ASHRAE design day conditions, 10% oversizing assumed.
Thermostat setpoints	Occupied hours: 75 cooling, 70 heating Unoccupied hours: 80 cooling, 65 heating

A computer-generated sketch of the full-service restaurant prototype is shown in Figure 6.

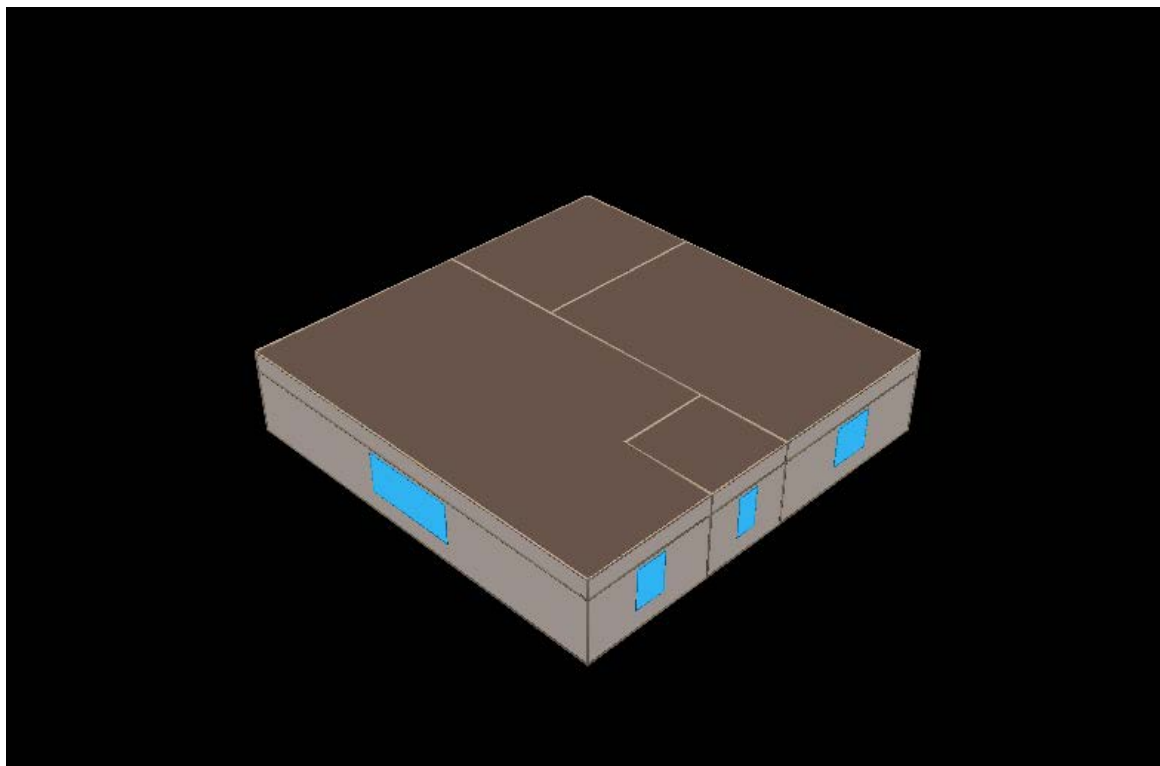

Figure 6. Full Service Restaurant Prototype Rendering

### Grocery

A prototypical building energy simulation model for a grocery building was developed using the DOE-2.2 building energy simulation program. The characteristics of the prototype are summarized in Table 22.

Table 22. Grocery Prototype Building Description

Characteristic	Value
Vintage	Existing (1970s) vintage
Size	50,000 square feet Sales: 40,000 SF Office and employee lounge: 3,500 SF Dry storage: 2,860 SF 50 °F prep area: 1,268 SF 35 °F walk-in cooler: 1,560 SF

## Appendix A – Technical Resource Manual

## Ameren Missouri

Characteristic	Value
	- 5 °F walk-in freezer: 812 SF
Number of floors	1
Wall construction and R-value	Concrete block with insulation, R-5
Roof construction and R-value	Metal frame with built-up roof, R-12
Glazing type	Single pane clear
Lighting power density	Sales: 3.36 W/SF Office: 2.2 W/SF Storage: 1.82 W/SF 50°F prep area: 4.3 W/SF 35°F walk-in cooler: 0.9 W/SF - 5°F walk-in freezer: 0.9 W/SF
Equipment power density	Sales: 1.15 W/SF Office: 1.73 W/SF Storage: 0.23 W/SF 50°F prep area: 0.23 W/SF + 36 kBtu/hr process load 35°F walk-in cooler: 0.23 W/SF + 17 kBtu/hr process load - 5°F walk-in freezer: 0.23 W/SF+ 29 kBtu/hr process load
Operating hours	Mon-Sun: 6am – 10pm
HVAC system type	Packaged single zone, no economizer
Refrigeration system type	Air cooled multiplex
Refrigeration system size	Low temperature (-20°F suction temp): 23 compressor ton Medium temperature (18°F suction temp): 45 compressor ton
Refrigeration condenser size	Low temperature: 535 kBtu/hr THR Medium temperature: 756 kBtu/hr THR
Thermostat setpoints	Occupied hours: 74°F cooling, 70°F heating Unoccupied hours: 79°F cooling, 65°F heating

A computer-generated sketch of the prototype is shown in Figure 7.

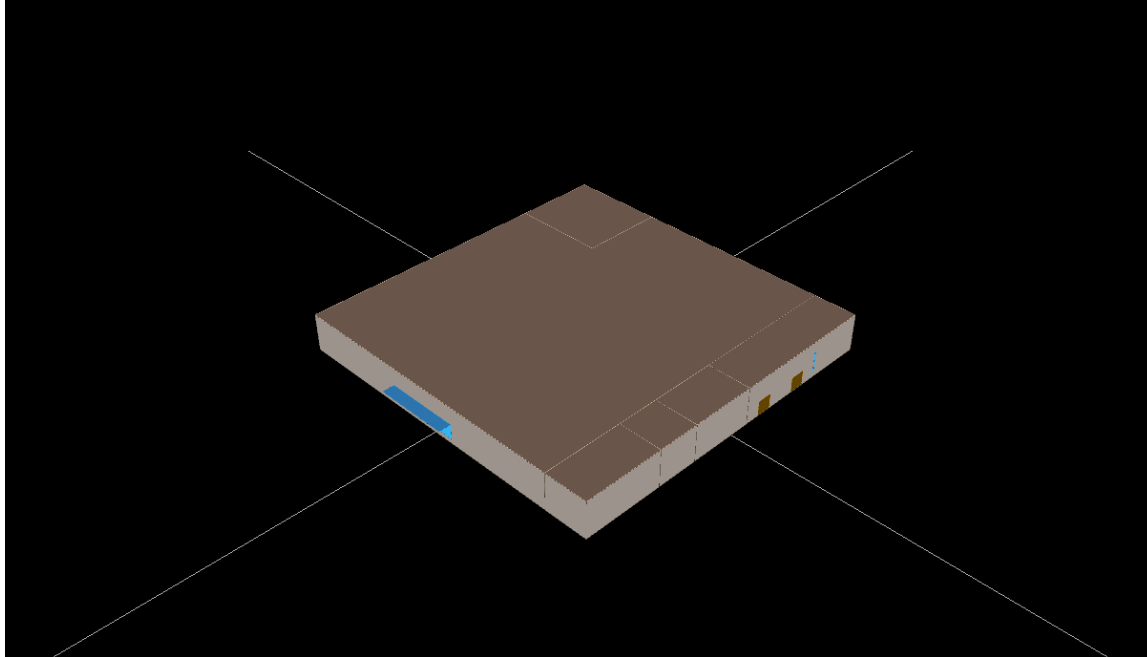

**Figure 7. Grocery Building Rendering**

### **HOSPITAL**

A prototypical building energy simulation model for a large hospital building was developed using the DOE-2.2 building energy simulation program. The characteristics of the prototype are summarized in Table 23.

**Table 23. Large Hospital Prototype Building Description**

Characteristic	Value
Vintage	Existing (1970s) vintage
Size	250,000 square feet
Number of floors	3
Wall construction and R-value	Brick and CMU, R=7.5
Roof construction and R-value	Built-up roof, R-13.5
Glazing type	Multipane; Shading-coefficient = 0.84 U-value = 0.72
Lighting power density	Patient rooms: 2.3 W/SF Office: 2.2 W/SF Lab: 4.4 Dining: 1.7 Kitchen and food prep: 4.3
Plug load density	Patient rooms: 1.7 W/SF Office: 1.7 W/SF Lab: 1.7 Dining: 0.6 Kitchen and food prep: 4.6
Operating hours	24/7, 365
HVAC system types	Patient Rooms: 4 pipe fan coil

Characteristic	Value
	Kitchen: Rooftop DX Remaining space; 1. Central constant volume system with hydronic reheat, without economizer; 2. Central constant volume system with hydronic reheat, with economizer; 3. Central VAV system with hydronic reheat, with economizer
HVAC system size	Based on ASHRAE design day conditions, 10% oversizing assumed.
Chiller type	Water cooled and air cooled
Chilled water system type	Constant volume with 3 way control valves,
Chilled water system control	Constant CHW Temp, 45 deg F setpoint
Boiler type	Hot water, 80% efficiency
Hot water system type	Constant volume with 3 way control valves,
Hot water system control	Constant HW Temp, 180 deg F setpoint
Thermostat setpoints	Occupied hours: 76 cooling, 72 heating Unoccupied hours: 81 cooling, 67 heating

Each set of measures was run using each of three different HVAC system configurations – a constant volume reheat system without economizer, a constant volume reheat system with economizer and a VAV system with economizer. The constant volume reheat system without economizer represents system with the most heating and cooling operating hours, while the VAV system with economizer represents a system with the least heating and cooling hours. This presents a range of system loads and energy savings for each measure analyzed.

A computer-generated sketch of the prototype is shown in Figure 15

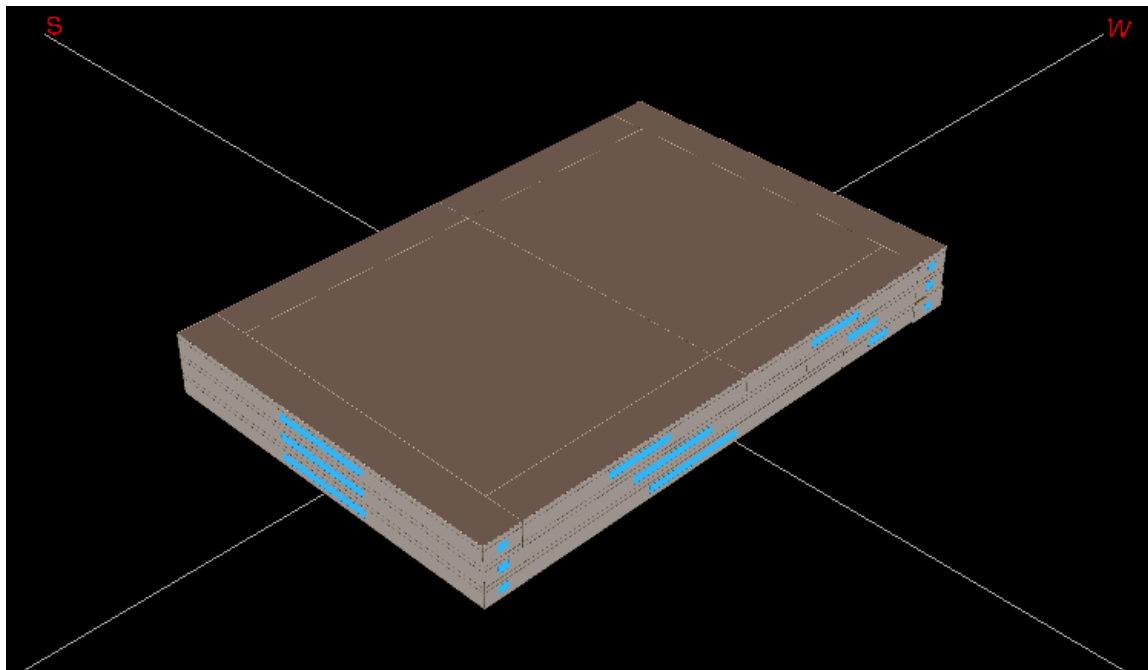



## Figure 15. Hospital Building Rendering

**Hotel**

A prototypical building energy simulation model for a Hotel building was developed using the DOE-2.2 building energy simulation program. The characteristics of the prototype are summarized in Table 24.

**Table 24. Hotel Prototype Building Description**

Characteristic	Value
Vintage	Existing (1970s) vintage
Size	200,000 square feet total Bar, cocktail lounge – 800 SF Corridor – 20,100 SF Dining Area – 1,250 SF Guest rooms – 160,680 SF Kitchen – 750 SF Laundry – 4,100 SF Lobby – 8,220 Office – 4,100 SF
Number of floors	11
Wall construction and R-value	Block construction, R-7.5
Roof construction and R-value	Wood deck with built-up roof, R-13.5
Glazing type	Multipane; Shading-coefficient = 0.84 U-value = 0.72
Lighting power density	Bar, cocktail lounge – 1.7 W/SF Corridor – 1.0 W/SF Dining Area – 1.7 W/SF Guest rooms – 0.6 W/SF Kitchen – 4.3 W/SF Laundry – 1.8 W/SF Lobby – 3.1 W/SF Office – 2.2 W/SF
Plug load density	Bar, cocktail lounge – 1.2 W/SF Corridor – 0.2 W/SF Dining Area – 0.6 W/SF Guest rooms – 0.6 W/SF Kitchen – 3.0 W/SF Laundry – 3.5 W/SF Lobby – 0.6 W/SF Office – 1.7 W/SF
Operating hours	Rooms: 60% occupied 40% unoccupied All others: 24 hr / day
HVAC system type	Central built-up system: All except corridors and rooms 1. Central constant volume system with perimeter hydronic reheat, without economizer; 2. Central constant volume system with perimeter hydronic reheat, with economizer;

Characteristic	Value
	3. Central VAV system with perimeter hydronic reheat, with economizer PTAC : Guest rooms PSZ: Corridors
HVAC system size	Based on ASHRAE design day conditions, 10% oversizing assumed.
Chiller type	Water cooled and air cooled
Chilled water system type	Constant volume with 3 way control valves,
Chilled water system control	Constant CHW Temp, 45 deg F setpoint
Boiler type	Hot water, 80% efficiency
Hot water system type	Constant volume with 3 way control valves,
Hot water system control	Constant HW Temp, 180 deg F setpoint
Thermostat setpoints	Occupied hours: 76 cooling, 72 heating Unoccupied hours: 81 cooling, 67 heating

A computer-generated sketch of the prototype is shown in Figure 17. Note, the middle floors, since they thermally equivalent, are simulated as a single floor, and the results are multiplied by 9 to represent the energy consumption of the 9 middle floors.

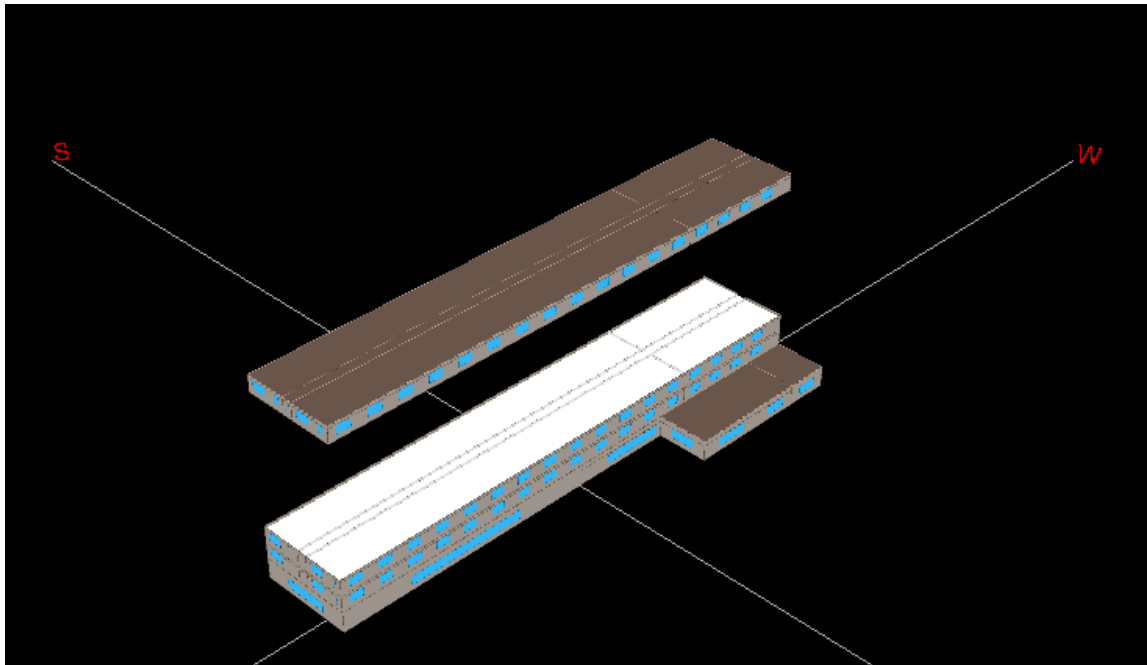

Figure 17. Hotel Building Rendering

### Large Office

A prototypical building energy simulation model for a large office building was developed using the DOE-2.2 building energy simulation program. The characteristics of the prototype are summarized in

Table 25.

**Table 25. Large Office Prototype Building Description**

Characteristic	Value
Vintage	Existing (1970s) vintage
Size	350,000 square feet
Number of floors	10
Wall construction and R-value	Glass curtain wall, R-7.5
Roof construction and R-value	Built-up roof, R-13.5
Glazing type	Multipane; Shading-coefficient = 0.84 U-value = 0.72
Lighting power density	Perimeter offices: 1.55 W/SF Core offices: 1.45 W/SF
Plug load density	Perimeter offices: 1.6 W/SF Core offices: 0.7 W/SF
Operating hours	Mon-Sat: 9am – 6pm Sun: Unoccupied
HVAC system types	1. Central constant volume system with perimeter hydronic reheat, without economizer; 2. Central constant volume system with perimeter hydronic reheat, with economizer; 3. Central VAV system with perimeter hydronic reheat, with economizer
HVAC system size	Based on ASHRAE design day conditions, 10% oversizing assumed.
Chiller type	Water cooled and air cooled
Chilled water system type	Constant volume with 3 way control valves,
Chilled water system control	Constant CHW Temp, 45 deg F setpoint
Boiler type	Hot water, 80% efficiency
Hot water system type	Constant volume with 3 way control valves,
Hot water system control	Constant HW Temp, 180 deg F setpoint
Thermostat setpoints	Occupied hours: 75 cooling, 70 heating Unoccupied hours: 80 cooling, 65 heating

Each set of measures was run using each of three different HVAC system configurations – a constant volume reheat system without economizer, a constant volume reheat system with economizer and a VAV system with economizer. The constant volume reheat system without economizer represents system with the most heating and cooling operating hours, while the VAV system with economizer represents a system with the least heating and cooling hours. This presents a range of system loads and energy savings for each measure analyzed.

A computer-generated sketch of the prototype is shown in Figure 8. Note, the middle floors, since they thermally equivalent, are simulated as a single floor, and the results are multiplied by 8 to represent the energy consumption of the 8 middle floors.

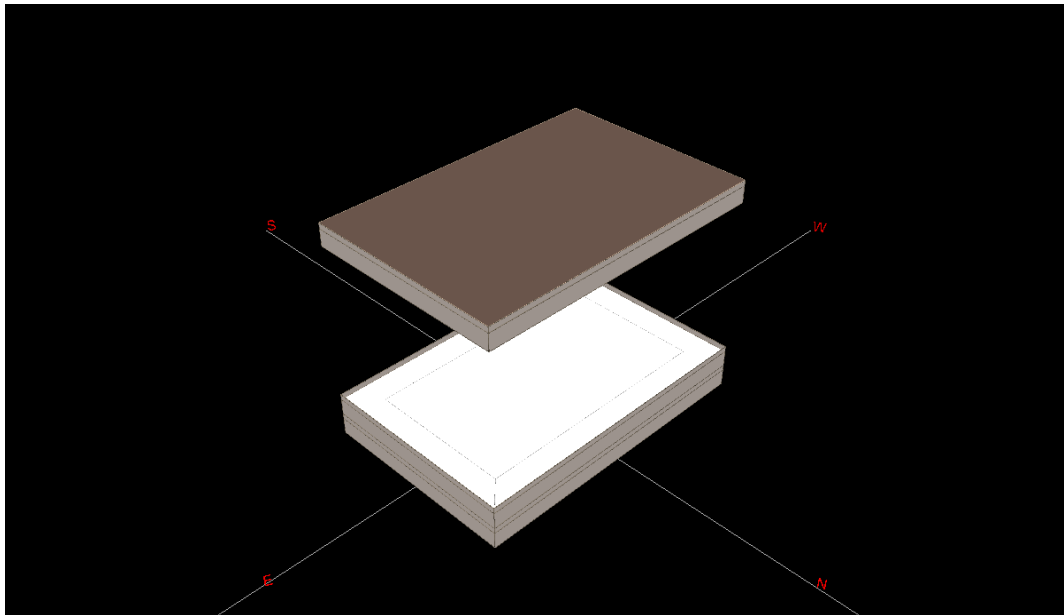

**Figure 8. Large Office Building Rendering**

### *Light Industrial*

A prototypical building energy simulation model for a light industrial building was developed using the DOE-2.2 building energy simulation program. The characteristics of the prototype are summarized in Table 26.

**Table 26. Light Industrial Prototype Building Description**

Characteristic	Value
Vintage	Existing (1970s) vintage
Size	100,000 square feet total 80,000 SF factory 20,000 SF warehouse
Number of floors	1
Wall construction and R-value	Concrete block with Brick, no insulation, R-5
Roof construction and R-value	Concrete deck with built-up roof, R-12
Glazing type	Multipane; Shading-coefficient = 0.84 U-value = 0.72
Lighting power density	Factory – 2.25 W/SF Warehouse – 0.7 W/SF
Plug load density	Factory – 1.2 W/SF Warehouse – 0.2 W/SF
Operating hours	Mon-Fri: 6am – 6pm Sat Sun: Unoccupied
HVAC system type	Packaged single zone, no economizer
HVAC system size	Based on ASHRAE design day conditions, 10% oversizing assumed.
Thermostat setpoints	Occupied hours: 75 cooling, 70 heating Unoccupied hours: 80 cooling, 65 heating

A computer-generated sketch of the prototype is shown in Figure 9.

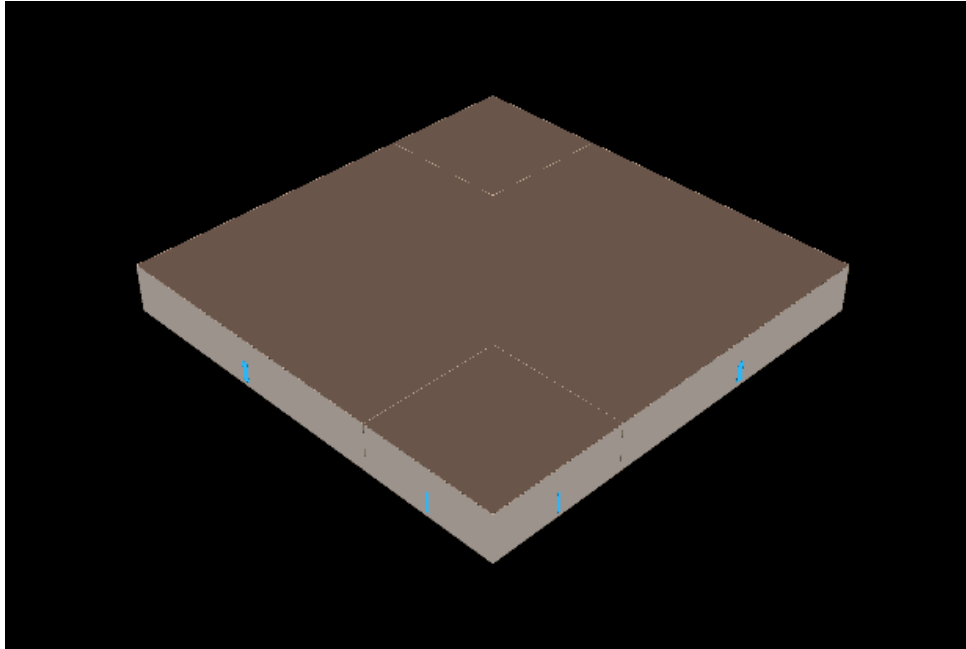

**Figure 9. Light Industrial Building Rendering**

### **Primary School**

A prototypical building energy simulation model for an elementary school was developed using the DOE-2.2 building energy simulation program. The model is really of two identical buildings oriented in two different directions. The characteristics of the prototype are summarized in Table 27.

**Table 27. Elementary School Prototype Building Description**

Characteristic	Value
Vintage	Existing (1970s) vintage
Size	2 buildings, 25,000 square feet each; oriented 90° from each other Classroom: 15,750 SF Cafeteria: 3,750 SF Gymnasium: 3,750 SF Kitchen: 1,750 SF
Number of floors	1
Wall construction and R-value	Concrete with brick veneer, R-7.5
Roof construction and R-value	Wood frame with built-up roof, R-13.5
Glazing type	Multipane Shading-coefficient = 0.84 U-value = 0.72
Lighting power density	Classroom: 1.8 W/SF Cafeteria: 1.3 W/SF Gymnasium: 1.7 W/SF Kitchen: 2.2 W/SF
Plug load density	Classroom: 1.2 W/SF Cafeteria: 0.6 W/SF

Characteristic	Value
	Gymnasium: 0.6 W/SF Kitchen: 4.2 W/SF
Operating hours	Mon-Fri: 8am – 6pm Sun: 8am – 4pm
HVAC system type	Packaged single zone, no economizer
HVAC system size	Based on ASHRAE design day conditions, 10% oversizing assumed.
Thermostat setpoints	Occupied hours: 75 cooling, 70 heating Unoccupied hours: 80 cooling, 65 heating

A computer-generated sketch of the prototype is shown in Figure 10.

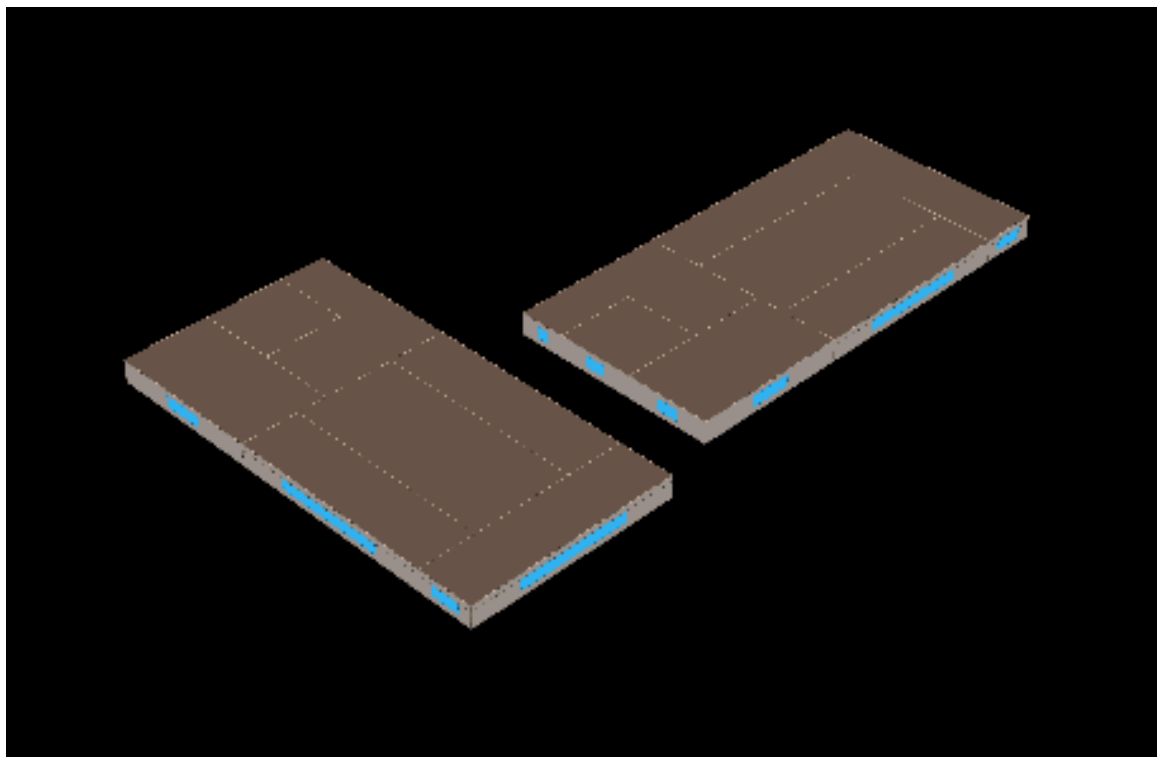

**Figure 10. School Building Rendering**

### **Small Office**

A prototypical building energy simulation model for a small office was developed using the DOE-2.2 building energy simulation program. The characteristics of the small office prototype are summarized in Table 28.

**Table 28. Small Office Prototype Building Description**

Characteristic	Value
Vintage	Existing (1970s) vintage
Size	10,000 square feet
Number of floors	2
Wall construction and R-value	Wood frame with brick veneer, R-7.5
Roof construction and R-value	Wood frame with built-up roof, R-13.5
Glazing type	Multipane; Shading-coefficient = 0.84 U-value = 0.72
Lighting power density	Perimeter offices: 1.55 W/SF Core offices: 1.45 W/SF
Plug load density	Perimeter offices: 1.6 W/SF Core offices: 0.7 W/SF
Operating hours	Mon-Sat: 9am – 6pm Sun: Unoccupied
HVAC system type	Packaged single zone, no economizer
HVAC system size	Based on ASHRAE design day conditions, 10% oversizing assumed.
Thermostat setpoints	Occupied hours: 75 cooling, 70 heating Unoccupied hours: 80 cooling, 65 heating

A computer-generated sketch of the small office prototype is shown in Figure 11.

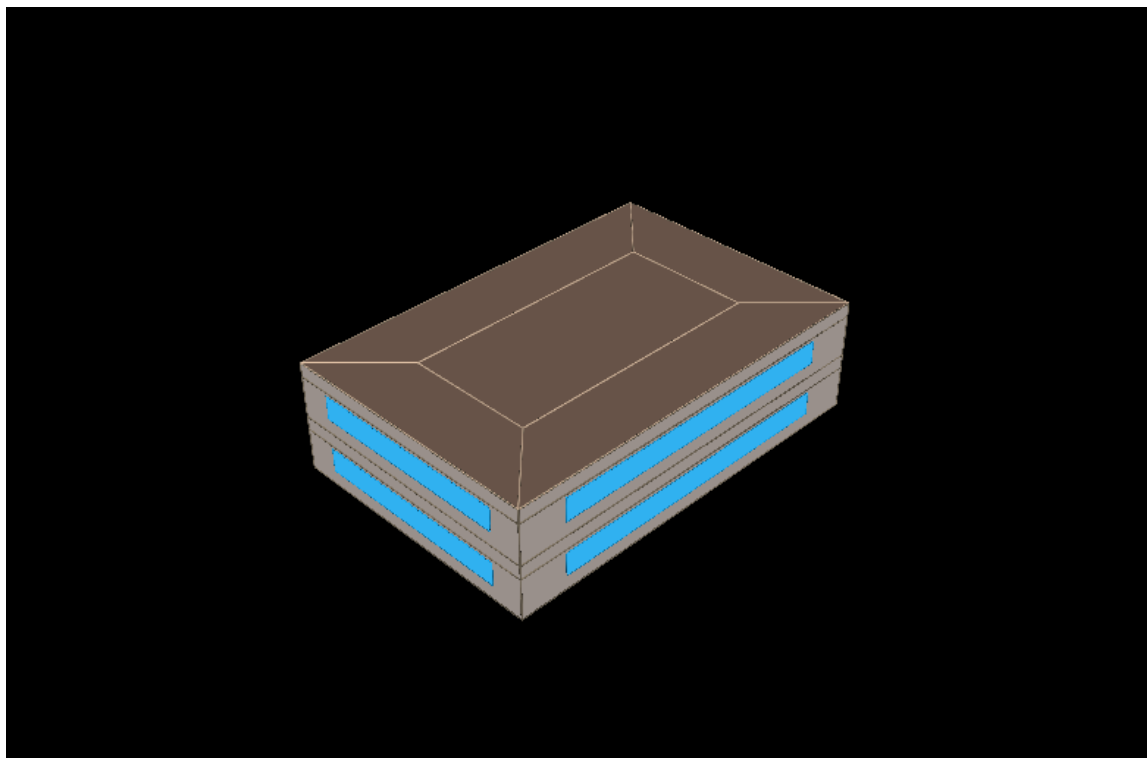

**Figure 11. Small Office Prototype Building Rendering**

**Small Retail**

A prototypical building energy simulation model for a small retail building was developed using the DOE-2.2 building energy simulation program. The characteristics of the small retail building prototype are summarized in Table 29.

**Table 29. Small Retail Prototype Description**

Characteristic	Value
Vintage	Existing (1970s) vintage
Size	6400 square foot sales area 1600 square foot storage area 8000 square feet total
Number of floors	1
Wall construction and R-value	Concrete block with brick veneer, R-7.5
Roof construction and R-value	Wood frame with built-up roof, R-13.5
Glazing type	Multipane; Shading-coefficient = 0.84 U-value = 0.72
Lighting power density	Sales area: 2.15 W/SF Storage area: 0.85 W/SF (Active) 0.45 W/SF (Inactive)
Plug load density	Sales area: 1.2 W/SF Storage area: 0.2 W/SF
Operating hours	10 – 10 Monday-Saturday 10 – 8 Sunday
HVAC system type	Packaged single zone, no economizer
HVAC system size	Based on ASHRAE design day conditions, 10% oversizing assumed.
Thermostat setpoints	Occupied hours: 75 cooling, 70 heating Unoccupied hours: 80 cooling, 65 heating

A computer-generated sketch of the small retail building prototype is shown in Figure 12.



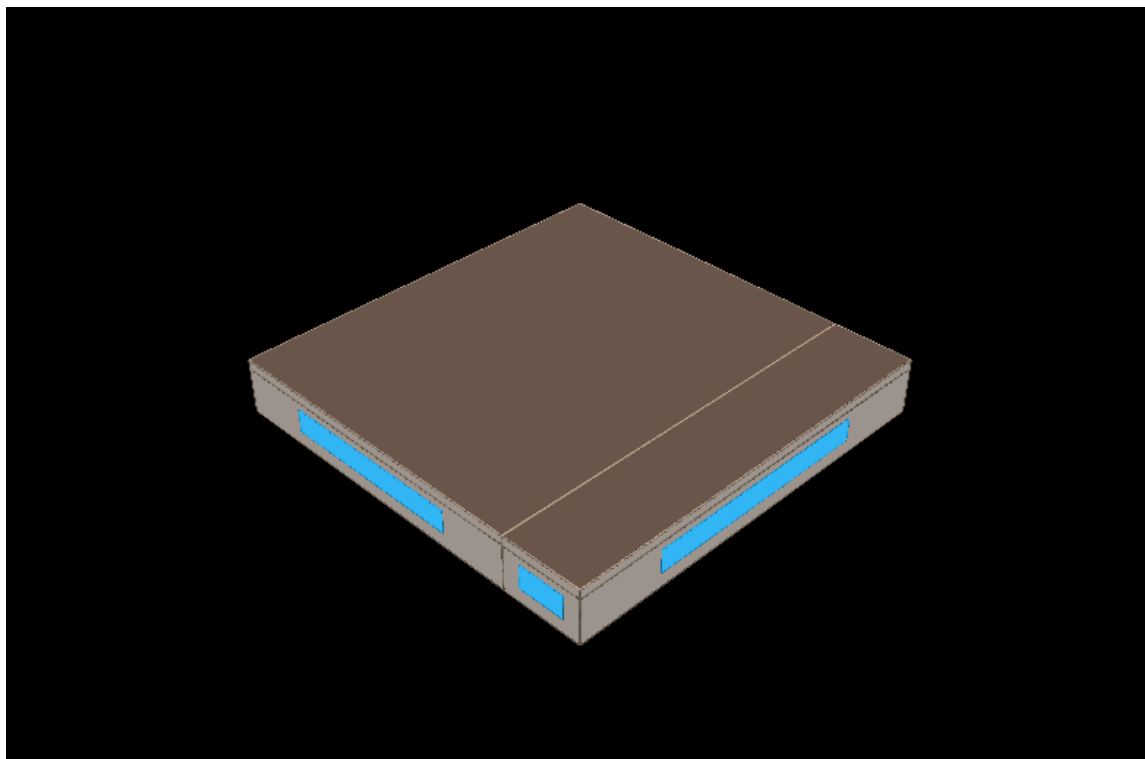

Figure 12. Small Retail Prototype Building Rendering

### Warehouse

A prototypical building energy simulation model for a warehouse building was developed using the DOE-2.2 building energy simulation program. The characteristics of the prototype are summarized in Table 30.

Table 30. Warehouse Prototype Building Description

Characteristic	Value
Vintage	Existing (1970s) vintage
Size	500,000
Number of floors	1
Wall construction and insulation R-value	Concrete block, R-5
Roof construction and insulation R-value	Wood deck with built-up roof, R-12
Glazing type	Multipane; Shading-coefficient = 0.84 U-value = 0.72
Lighting power density	0.9 W/SF
Plug load density	0.2 W/SF
Operating hours	Mon-Fri: 7am – 6pm Sat Sun: Unoccupied
HVAC system type	Packaged single zone, no economizer
HVAC system size	Based on ASHRAE design day conditions, 10% oversizing assumed.
Thermostat setpoints	Occupied hours: 80 cooling, 68 heating Unoccupied hours: 85 cooling, 63 heating

A computer-generated sketch of the prototype is shown in Figure 16.

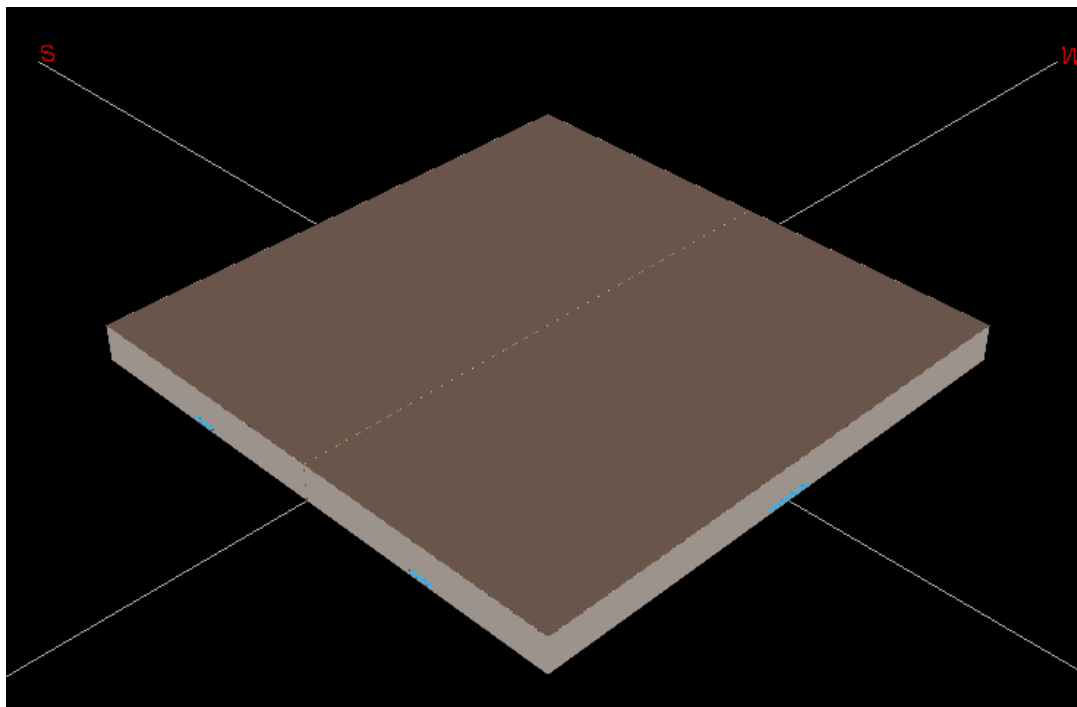

Figure 16. Warehouse Building Rendering

### Commercial Building Measure Savings Analysis

Commercial building measures included efficiency upgrades to the heating and cooling equipment, HVAC control measures, building shell measures. A matrix of the measures and their applicability across each of the commercial building types is shown in Table 31 and 32. The assumptions used in the analysis are described in the following sections.

## Appendix A – Technical Resource Manual

## Ameren Missouri

Table 31. Measure Applicability by Small Commercial Building Type

	Assembly	Big Box Retail	Fast Food Restaurant	Full Service Restaurant	Grocery	Light Industrial	Primary School	Small Office	Small Retail	Warehouse
Anti Sweat Heater Control					✓					
Cool Roof	✓	✓	✓	✓		✓	✓	✓	✓	✓
Demand Controlled Ventilation	✓	✓	✓	✓		✓	✓	✓	✓	✓
Economizer	✓	✓	✓	✓		✓	✓	✓	✓	✓
Efficient Condenser					✓					
Engineered CKV hood			✓	✓						
Floating Head Pressure Control					✓					
Gas Furnace	✓	✓	✓	✓		✓	✓	✓	✓	✓
High Performance Glazing	✓	✓	✓	✓		✓	✓	✓	✓	✓
Infrared Heater						✓				✓
Night Covers					✓					
PTAC							✓	✓	✓	
PTAC-HP							✓	✓	✓	
Refrigerant Charge Correction	✓	✓	✓	✓		✓	✓	✓	✓	✓
Roof Insulation	✓	✓	✓	✓		✓	✓	✓	✓	✓
Rooftop Air Conditioners	✓	✓	✓	✓		✓	✓	✓	✓	✓
Rooftop Air Source Heat Pump	✓	✓	✓	✓		✓	✓	✓	✓	✓
Setback/Setup	✓	✓	✓	✓		✓	✓	✓	✓	✓
Water Loop Heat Pump	✓						✓	✓		
Window Film	✓	✓	✓	✓		✓	✓	✓	✓	✓

Table 32. Measure Applicability by Large Commercial Building Type

	Large Office	Hotel	Hospital
Air-Cooled Chiller	✓	✓	✓
Boiler	✓	✓	✓
CHW Reset	✓	✓	✓
Cool Roof	✓	✓	✓
Demand Controlled Ventilation	✓	✓	✓
Economizer	✓	✓	✓
Energy Management System	✓	✓	✓
Gas Engine Chiller	✓	✓	✓
High Performance Glazing	✓	✓	✓
Roof Insulation	✓	✓	✓
Setback/Setup	✓	✓	✓
VFD Fan	✓	✓	✓
VFD Pump	✓	✓	✓
Water-Cooled Chiller	✓	✓	✓
Window Film	✓	✓	✓

### HVAC Equipment Efficiency Upgrades

The HVAC equipment efficiency measures include upgrades to single package rooftop air conditioners and heat pumps, split system air conditioners and heat pumps, packaged terminal air conditioners and heat pumps, and ground source and water loop heat pumps in a variety of size ranges. The program baseline is defined by the National Appliance Energy Conservation Act (NAECA) minimum efficiency for single phase equipment and ASHRAE 90.1 – 2004 minimum efficiency for three phase equipment. HVAC measures cover the upgrade of standard efficiency packaged HVAC systems with high efficiency versions of the same equipment. A separate set of simulations were conducted to address the energy savings associated with changing from a rooftop air cooled heat pump system to a ground-source heat pump system in selected building types.

The HVAC equipment covered, the size ranges, and the program baseline efficiency assumptions are shown in Table 33.

**Table 33. Unitary HVAC Equipment Measure Efficiency Assumptions**

Equipment Category	Capacity Range (Btu/hr)	Baseline Efficiency	Baseline Source	Measure Efficiency
Packaged Terminal A/C	All	8.9 EER	ASHRAE 90.1-2004	9.2
Packaged Terminal HP	All	8.7 EER	ASHRAE 90.1-2004	9.0
Unitary A/C (1 ) phase	<65,000 1 Ph	13.0 SEER	NAECA	14.0
Unitary A/C (3) phase	<65,000 3 Ph	12.0 SEER	ASHRAE 90.1-2004	13.0
Unitary A/C (3) phase	65,000 - 135,000	10.1 EER	ASHRAE 90.1-2004	11.0
Unitary A/C (3) phase	135,000 - 240,000	9.5 EER	ASHRAE 90.1-2004	11.0
Unitary A/C (3) phase	240,000 - 760,000	9.3 EER	ASHRAE 90.1-2004	10.0
Unitary A/C (3) phase	>760,000	9.0 EER	ASHRAE 90.1-2004	10.0
Unitary HP (1) phase	<65,000 1 Ph	13.0 SEER	NAECA	14.0
Unitary HP (3) phase	<65,000 3 Ph	12.0 SEER	ASHRAE 90.1-2004	13.0
Unitary HP (3) phase	65,000 - 135,000	9.9 EER	ASHRAE 90.1-2004	11.0
Unitary HP (3) phase	135,000 - 240,000	9.1 EER	ASHRAE 90.1-2004	10.0
Unitary HP (3) phase	>240,000	8.8 EER	ASHRAE 90.1-2004	10.0
Ground Source HP	<135,000 & 77F EWT	13.4 EER	ASHRAE 90.1-2004	17 EER and 19

## Appendix A – Technical Resource Manual

## Ameren Missouri

Equipment Category	Capacity Range (Btu/hr)	Baseline Efficiency	Baseline Source	Measure Efficiency
				EER
Water Loop Heat Pump	<17,000 & 86F EWT	11.2 EER	ASHRAE 90.1-2004	11.5
Water Loop Heat Pump	17,000 - 65,000 & 86F EWT	12.0 EER	ASHRAE 90.1-2004	12.3
Water Loop Heat Pump	65,000 - 135,000 & 86F EWT	12.0 EER	ASHRAE 90.1-2004	12.3

Rooftop AC units with gas heat were simulated with high efficiency gas heating sections. The simulations modeled improvement from a 78 AFUE baseline furnace section to a 95 AFUE furnace.

An infrared heater simulation was conducted for the light manufacturing prototype, where the baseline system was a standard efficiency gas unit heater. Energy savings from the infrared heating system were simulated by lowering the room heating temperature setpoint by 5 degrees F and eliminating the fan energy consumption. Combustion efficiency between the baseline unit heater and the infrared heater was assumed to remain constant.

Chiller efficiency improvements were analyzed for the Large Office prototype. The efficiency scenarios covered a range of full load and part load Integrated Part Load Value (IPLV) efficiencies for air cooled reciprocating and screw chillers; and water cooled screw and centrifugal chillers of various size ranges. Full load efficiency improvements of 10% and 20% were evaluated. The 10% improvement is coincident with the Federal Energy Management Program (FEMP) program guidelines, while the 20% efficiency improvement was run as an aggressive case. Part load (IPLV) improvement scenarios were run at each full-load efficiency level, covering a range of IPLV improvements available from variable speed drive chillers. An efficient gas engine chiller was also simulated relative to a standard gas engine chiller baseline. The baseline and efficient equipment efficiencies are summarized in Table 34.

**Table 34. Chiller Measure Efficiency Assumptions**

Equipment Category	Capacity Range (Btu/hr)	Baseline Full-load Efficiency (kW/ton)	Baseline IPLV (kW/ton)	Measure Efficiency (kW/ton)	Measure IPLV (kW/ton)
Air-Cooled Chiller	All	1.26	1.15	1.05 – 1.14	0.62 – 1.02
Water-Cooled Screw Chiller	<150 tons	0.79	0.68	0.63 - 0.79	0.38 – 0.62
	150 – 300 ton	0.72	0.63	0.57 – 0.72	0.34 - 0.57
	> 300 ton	0.64	0.57	0.51 - .064	0.31 -0.51
Water-Cooled Centrifugal Chiller	<150 tons	0.70	0.67	0.56 - 0.7	0.34 - 0.60
	150 – 300 ton	0.63	0.60	0.51 – 0.63	0.30 - 0.54
	> 300 ton	0.58	0.55	0.46 – 0.58	0.29 - 0.49
Gas Engine Chiller	All	1.6 COP		1.76 COP	

High efficiency boilers were applied to the Large Office prototype, assuming a thermal efficiency of 80% in the base case and 85% for the measure.

### **HVAC Control Measures**

A series of HVAC control and system tune-up measures were also analyzed. Dual temperature air side economizer systems were added to both packaged rooftop and built-up systems. Chilled water reset controls were analyzed for both air cooled and water cooled chiller systems. Variable frequency drives on air handlers and pumps were analyzed. The VFD fan applications simulated VFDs applied to both the supply and return fans of the VAV built up system air handlers in the large commercial buildings. Inlet vane control was assumed in the base case. VFD pumping applications were simulated by applying a VFD to the secondary loop of a constant volume primary/secondary pumping system. Three-way chilled water coil control valves were assumed in the base case, while the variable flow case assumed two-way control valves.

Demand controlled ventilation (DCV) systems were simulated by adding an air-side economizer with zone-level CO<sub>2</sub> sensor controls to the packaged rooftop equipment, thus the savings represent the combined effect of the DCV and the air side economizer. For the built up systems using in the large commercial building prototypes, outdoor air volume control based on return air CO<sub>2</sub> sensors was simulated. The simulations calculated the effect of the DCV controls only. In all cases, minimum outside ventilation rates tracked the occupancy schedules used to define the prototypes.

Setback thermostats (assumed to be present in the base building) were analyzed by comparing the baseline building simulations to a no-setback simulation. A refrigerant charge adjustment measure was analyzed for rooftop air conditioners. The simulations assumed an undercharged scenario where the charge correction improved the unit efficiency by 10%.

A simple EMS upgrade was simulated by combining the chilled water reset controls with hot water, chilled water and condenser pump on/off controls that turn the pumps off when heating and/or cooling are not needed.

The HVAC control and system tune-up measure assumptions are summarized in Table 35.

**Table 35. HVAC Control and System Tune-up Measure Assumptions**

Measure	Baseline Assumption	Measure Assumption
Chilled Water Reset – Air-Cooled Chiller	45°F fixed chilled-water temperature setpoint	Chilled-water temperature allowed to increase by 5°F or 10°F during periods of low load.
Chilled Water Reset – Water-Cooled Chiller	45°F fixed chilled-water temperature setpoint	Chilled-water temperature allowed to increase by 5°F or 10°F during periods of low load.
Demand controlled ventilation	Fixed outside air without economizer	Dual temperature air-side economizer with zone-level CO <sub>2</sub> sensors for rooftop units; return system CO <sub>2</sub> sensors for built up systems.

Measure	Baseline Assumption	Measure Assumption
Economizer	Fixed outside air without economizer	Dual temperature air-side economizer
Setback Thermostat	No setback/setup during unoccupied hours	Temperatures are setback/setup during unoccupied hours
Refrigerant Charge adjustment for rooftop AC	Cooling capacity and EIR degraded by 10% to reflect “typical” refrigerant charge	Standard cooling performance – proper refrigerant charge
VFD on air-handler fan	Inlet vane controlled VAV	VSD controlled VAV
VFD on chilled-water pumps	3-way valve with single-speed chilled-water pump	VSD controlled chilled-water pump with 2 way control valves
EMS	Constant chilled water temperature setpoint, loop pumps operating 24/7	Chilled water temperature setback and on/off scheduling of loop pumps

### Shell Measures

Shell measures included window films applied to the existing double pane clear glass, high performance tinted low-e glazing compliant with ASHRAE 90.1-2004, upgraded roof insulation and “cool roofs.” A summary of the shell measure assumptions is shown in Table 36.

**Table 36. Shell Measure Assumptions**

Measure	Baseline Assumption	Measure Assumption
High Performance Glazing	Clear, double-pane Shading-coefficient =	SHGC = 0.39 U-value = 0.57
Window Film	.84 U-value = .72	SHGC = 0.39 U-value = .72
Roof insulation	Varies by prototype	R-18
Cool roof	Solar absorptance = 0.8	Solar absorptance = 0.3

### Refrigeration Measures

The grocery store prototype building was used to analyze a set of refrigeration measures. The measures included efficient air-cooled condensers, floating head pressure control, night covers and anti-sweat heater controls. The air cooled condenser measure assumed an oversized condenser with improved condenser fan efficiency. The base case condenser assumed a 15°F temperature difference between the condensed liquid and outdoor air temperature under design conditions for low temperature systems and a 20°F temperature difference for medium temperature systems. The efficient case assumed the temperature difference of 8°F and 13°F for low and medium temperature systems respectively. The



efficiency of the fan was also considered. The base system assumed 45 Btu/hr of heat rejection<sup>14</sup> per watt of fan power, while the efficient case assumed 85 Btu/hr of heat rejection per watt of fan power.

Floating head pressure controls were simulated by allowing the condenser fans to run until a 70°F condensing temperature was achieved compared to an 85°F condensing temperature in the base case. Night covers were simulated by reducing the infiltration rate on medium temperature open multi-deck cases by 50% for 4 hours per day while the night covers were deployed. Anti-sweat heater controls were simulated by controlling the door anti-sweat heaters on low temperature reach-in cases according to store dewpoint temperature. Door heater energy is reduced starting at a dewpoint temperature setpoint of 55°F and are shut off completely at a 33°F dewpoint temperature. Door heaters are assumed to run continuously in the base case.

The refrigeration measure assumptions are summarized in Table 37.

**Table 37. Grocery Refrigeration Measure Assumptions**

Measure	Baseline Assumption	Measure Assumption
Efficient Refrigeration Condenser	Low Temp: 15°F approach; 45 Btu/hr - watt Medium Temp: 20°F approach; 45 Btu/hr - watt	Low Temp: 8°F approach; 85 Btu/hr-watt Medium Temp: 13°F approach; 85 Btu/hr-watt
Floating Head Pressure Control	SCT controlled to 85°F fixed setpoint	SCT controlled to 70°F setpoint
Night Covers on Open Case	Open cases with no night cover	Open cases covered 4 hrs/night Reduces infiltration by 50%
Anti-Sweat Heater Controls	Uncontrolled anti-sweat heaters on case doors	Anti-sweat heaters controlled based on store interior dewpoint temperature.

### Other Measures

The impacts of engineered commercial kitchen ventilation (CKV) systems were simulated for the fast food and full service restaurant buildings. Engineered CKV systems can reduce the ventilation rates for the cookline ventilation hoods by 50% to 60%. The size of the hoods and the ventilation air requirements vary widely by restaurant, so the impacts of this technology were normalized per 100 cfm of ventilation air reduction. The makeup air for the system is assumed to be introduced through the kitchen HVAC systems, rather than through a dedicated makeup air heater.

### Simulation Results

Annual kWh, summer and winter peak kW, and gas therm savings estimates were developed based on differences between the simulated energy consumption and peak demand at the baseline and the

<sup>14</sup> Heat rejection rates are based on a 10 degree F temperature difference for this specification.

measure efficiency levels. Summer peak demand was assumed to occur during the month of July, while winter peak impacts were calculated during the month of January. The set of simulations described above were conducted for St. Louis, MO. The TMY3 long term average weather data set was used. The simulated savings were normalized using appropriate units – tons for cooling measures, 100 square feet of window area for window measures, etc.

Measure cost data were compiled from a combination of the DEER database and cost estimation conducted by Franklin Energy. Base case equipment costs, measure costs, and labor costs to install the equipment were compiled. The incremental costs are reported as the difference between the baseline and measure equipment costs, exclusive of labor costs. The installed costs are the sum of the measure costs and the installation labor costs. First costs only are reported; incremental maintenance costs are assumed to be zero.

The base case for most of the measures in this study assumes a normal replacement scenario, where the equipment has reached the end of its service life and must be replaced. The energy savings are evaluated against standard efficiency replacement equipment (assumed to be either code or standard industry practice). In these instances, the incremental measure costs should be used to evaluate measure cost effectiveness.

Normalized measure savings and cost data are included in a separate electronic file. The energy and cost data are all normalized to the same units. A typical measure sized is included as appropriate to estimate the energy savings and costs for a typical measure in each size range.

## Appendix A – Technical Resource Manual

<u>Table of Abbreviations .....</u>	<u>iii</u>
<u>Introduction .....</u>	<u>1</u>
<u>Special issues .....</u>	<u>2</u>
<u>Protocol for Deeming Measures Not Found Within TRM .....</u>	<u>4</u>
<u>Residential Energy Efficiency Measures .....</u>	<u>5</u>
<u>Residential Lighting .....</u>	<u>5</u>
<u>Residential HVAC Applications .....</u>	<u>7</u>
<u>Residential Appliances .....</u>	<u>30</u>
<u>Residential Building Shell .....</u>	<u>37</u>
<u>Residential Water Heating .....</u>	<u>40</u>
<u>Commercial and Industrial Energy Efficiency Measures .....</u>	<u>46</u>
<u>Commercial Lighting .....</u>	<u>46</u>
<u>Commercial Cooking Equipment .....</u>	<u>58</u>
<u>Commercial Refrigeration .....</u>	<u>62</u>
<u>Commercial Hot Water Measures .....</u>	<u>69</u>
<u>Commercial Pumps and Drives .....</u>	<u>71</u>
<u>Commercial HVAC Applications .....</u>	<u>75</u>
<u>Commercial Miscellaneous .....</u>	<u>85</u>
<u>Commercial Optimization Measures .....</u>	<u>87</u>
<u>Custom Project Analysis Methodology .....</u>	<u>90</u>
<u>Building Simulation Protocols .....</u>	<u>104</u>
<u>Table of Abbreviations .....</u>	<u>iiii</u>
<u>Introduction .....</u>	<u>1</u>
<u>Special issues .....</u>	<u>2</u>
<u>Protocol for Deeming Measures Not Found Within TRM .....</u>	<u>4</u>
<u>Residential Energy Efficiency Measures .....</u>	<u>5</u>
<u>Residential Lighting .....</u>	<u>5</u>
<u>Residential HVAC Applications .....</u>	<u>7</u>
<u>Residential Appliances .....</u>	<u>30</u>
<u>Residential Building Shell .....</u>	<u>37</u>
<u>Residential Water Heating .....</u>	<u>40</u>
<u>Commercial and Industrial Energy Efficiency Measures .....</u>	<u>46</u>
<u>Commercial Lighting .....</u>	<u>46</u>
<u>Commercial Cooking Equipment .....</u>	<u>58</u>

**Appendix A – Technical Resource Manual****Ameren Missouri**

---

Commercial Refrigeration .....	<u>62</u>
Commercial Hot Water Measures .....	<u>69</u>
Commercial Pumps and Drives .....	<u>71</u>
Commercial HVAC Applications .....	<u>75</u>
Commercial Miscellaneous .....	<u>85</u>
Commercial Optimization Measures .....	<u>87</u>
Custom Project Analysis Methodology .....	<u>90</u>
Building Simulation Protocols .....	<u>104</u>

## Appendix A – Technical Resource Manual

## Ameren Missouri

## Table of Abbreviations

<u>Term</u>	<u>Abbrev</u>	<u>Term</u>	<u>Abbrev</u>
Air Source Heat Pump	ASHP	American Society of Heating, Refrigerating & Air-Conditioning Engineers	ASHRAE
Annual Fuel Utilization Efficiency	AFUE	Building Automation System	BAS
Central Air Conditioner	CAC	Compact Fluorescent Light	CFL
Database for Energy Efficiency Resources	DEER	Demand controlled ventilation	DCV
Department of Energy	DOE	Dual Fuel Heat Pump	DFHP
<del>Effective Useful Life</del>	<del>EUL</del>	<del>Energy Efficiency Ratio</del>	<del>EER</del>
Electronically Commutated Motors	ECM	<del>Energy Management System</del> <del>Energy Efficiency Ratio</del>	<del>EMSEER</del>
Energy Independence & Security Act	EISA	<del>Equivalent Full Load Hours</del> <del>Energy Management System</del>	<del>EFLHEMS</del>
Environmental Protection Agency	EPA	<del>Federal Energy Management Program</del> <del>Equivalent Full Load Hours</del>	<del>FEMPEFLH</del>
Evaluation Measurement & Verification	EMV	<del>Integrated Part Load Value</del> <del>Federal Energy Management Program</del>	<del>IPLVFEMP</del>
High Intensity Discharge	HID	<del>International Energy Conservation Code</del> <del>Integrated Part Load Value</del>	<del>IECC</del> <del>IPLV</del>
Integrated Resource Plan	IRP	<del>Kilowatt per Hour</del> <del>International Energy Conservation Code</del>	<del>kWh</del> <del>IECC</del>
Kilowatt	kW	<del>National Appliance Energy Conservation Act</del> <del>Kilowatt per Hour</del>	<del>NAECA</del> <del>kWh</del>
Missouri Energy Efficiency Investment Act	MEEIA	<del>Net Present Value</del> <del>National Appliance Energy Conservation Act</del>	<del>NPV</del> <del>NAECA</del>
National Electrical Manufacturers Association	NEMA	<del>Packaged Terminal Heat Pump</del> <del>Net Present Value</del>	<del>PTHP</del> <del>NPV</del>
Packaged Terminal Air Conditioner	PTAC	<del>Remaining Efficient Life</del> <del>Packaged Terminal Heat Pump</del>	<del>REL</del> <del>PTHP</del>
Real Discount Rate	RDR	<del>Seasonal Energy Efficiency Ratio</del> <del>Remaining Efficient Life</del>	<del>SEER</del> <del>REL</del>
Remaining Useful Life	RUL	<del>Technical Analysis Study</del> <del>Seasonal Energy Efficiency Ratio</del>	<del>TAS</del> <del>SEER</del>

**Appendix A – Technical Resource Manual****Ameren Missouri**

Solar Heat Gain Coefficient	SHGC	<del>Thermostatic Expansion Valves</del> <del>Technical Analysis Study</del>	<del>TXV</del> <del>TAS</del>
Technical Resource Manual	TRM	<del>Utility Discount Rate</del> <del>Thermostatic Expansion Valves</del>	<del>UDR</del> <del>TXV</del>
Typical Meteorological Year	TMY	<del>Variable Air Volume</del> <del>Utility Discount Rate</del>	<del>VAV</del> <del>UDR</del>
Unit Energy Consumption	UEC	<del>Variable Speed Drive</del> <del>Variable Air Volume</del>	<del>VSD</del> <del>VAV</del>
Variable Frequency Drive	VFD	<del>Variable Speed Drive</del>	<del>VSD</del>

## Introduction

The Ameren Missouri Technical Resource Manual (TRM) was developed to establish deemed measure level values and/or protocols for measures that cannot be deemed. These values and protocols will be used prospectively for the three year implementation cycle as defined in the Missouri Energy Efficiency Investment Act (MEEIA) rules.

The technologies are divided into 2 main sections, each contains multiple end-use categories.

- Residential Applications
  - Residential Lighting
  - Residential HVAC
  - Residential Appliances
  - Residential Building Shell
  - Residential Water Heating
  
- Commercial and Industrial Applications
  - Commercial Lighting
  - Cooking Equipment
  - Commercial Refrigeration
  - Commercial Hot Water Measures
  - Commercial Motors and Drives
  - Commercial HVAC Applications
  - Commercial Miscellaneous
  - Commercial Optimization Measures
  - Custom Project Analysis Methodology

A separate table is provided for each technology containing equations that can be used to calculate gross annual electric energy and demand savings. Furthermore, each table identifies baseline efficiency levels, which are used as the standard for which the energy efficient technology is measured against. The tables also highlight the minimum efficiency criteria required for the measure to receive a savings credit. Each measure is allocated a specific effective useful life (EUL), which is the amount of time that particular measure is expected to perform. Finally, each measure is also given an incremental cost, which indicates the cost differential between the baseline efficiency and the minimum required efficiency highlighted in each individual table. Key assumptions utilized for each measure are highlighted in a bulleted list below each table.

To arrive at the individual measure level assumptions, Ameren Missouri consulted multiple databases, Evaluation Measurement & Verification (EMV) Reports, and other TRMs. Missouri specific data, where available, took precedence over all other data available. Measure level values were given primary precedence if they came from

Ameren Missouri EMV reports. For measures not contained in the EMV reports, Ameren Missouri consulted its internal database developed by Morgan Marketing Partners which utilizes Missouri specific weather, building vintages, and home sizes. Finally, other state and utility TRMs were consulted including the 2005 Pennsylvania draft TRM and the 2009 Ohio TRM. These other TRMs were mainly used to derive engineering equations for estimating energy savings and other formatting ideas and practices, no measure level savings, costs, or effective useful lives were utilized from these TRMs.

The TRM values will be updated once every three years via the EM&V review process. Any new measure level data changes will be applied prospectively for the next three year implementation cycle. If there are measures not included within this TRM, or if new measures proliferate within Ameren Missouri's service territory, a process will be followed to include these new technologies as defined, starting on page 4.

### Special issues

In developing this TRM, several key issues arose that necessitate further discussion. The first topic involves weather sensitive measures. Typical weather sensitive measures include:

- HVAC measures (heat pumps, air conditioners, furnaces, chillers, etc.);
- Building shell (insulation, air sealing, duct sealing, windows, etc.);
- Thermostats;
- Energy Management Systems;
- Condensers;
- Other measures whose savings depend on weather.

For all weather sensitive measures not included in program year 2 (October 2009 – September 2010) EMV reports, building simulation modeling was conducted by Morgan Marketing Partners. The process is outlined, starting on page 99. The weather sensitive measure values reflected in this TRM as indicated by the footnote, “[#] Taken from Morgan Measure Libraries”, were derived using a building simulation approach. The equations listed provide a different method to estimate measure level savings in the case the user does not have access to the appropriate simulation modeling tools (DOE 2-2 or E-quest). The building simulation approach, however, is far more accurate and Ameren Missouri believes this is the best method to quantify measure level energy and demand savings.

Another issue that arose involves the demand savings estimates. The values represented within this TRM were either provided by EMV contractors or supplied by Morgan Marketing Partners. While these values are meant to represent the coincident peak demand savings, they may not be equivalent to the coincident savings that are



used when developing the Integrated Resource Plan (IRP). This is due to the operating characteristics of the energy efficiency modeling tool used by Ameren Missouri that models savings against class load shapes, which typically do not have peaks coincident with the Ameren Missouri system peak. The coincident peak impact used for developing the IRP is derived from “calibrated” end-use and system load shapes that were developed as part of the load forecasting process. A description of the forecast development process can be found in Chapter 3 of the Ameren Missouri 2011 IRP and specifics regarding the calibration of end-use load shapes are located in Section 3.2.2 of the Ameren Missouri 2011 IRP<sup>1</sup>. The appropriate “calibrated” end-use load shapes are applied to each energy efficiency measure energy savings and scaled based on the level of energy savings for that measure. The resulting hourly value that is coincident with the system peak is the coincident demand used for IRP development purposes. Ameren Missouri uses the loadshape methodology in the IRP process to maintain consistency with its load forecasting approach.

Early replacement measures are included in this TRM as well. This type of measure (mainly applicable to HVAC measures, specifically heat pumps and air conditioners) is exactly as the name suggests, replacing existing installed equipment with a new efficient alternative. Several key factors are involved when conducting early replacement cost effectiveness analysis.

1. Remaining effective useful life of the existing equipment (assumed to be 1/3 of the life of the equipment). For example, an air conditioner lasts 18 years, regardless of efficiency. The existing equipment installed in the home would then have 6 years of remaining useful life.
2. Remaining effective useful life of the efficient equipment (assumed to be 2/3 of the life of the equipment). For example, an air conditioner lasts 18 years, regardless of efficiency. The existing equipment installed in the home would then have 12 years of remaining useful life.
3. There are two levels of savings. One level of savings occurs from the new, efficient equipment and the existing, installed unit for the remaining effective useful life of the existing unit. The next level of savings is obtained by subtracting the current federal standard or code equipment’s consumption from the new efficient equipment. Example: replacing an existing Seasonal Energy Efficiency Ratio (SEER) 8 central air conditioner with a new SEER 15 air conditioner. There would be 6 years of savings for the first Tier (SEER 8 kWh – SEER 15 kWh), and then there would be 12 years of savings from the second tier (SEER 13 (code) kWh – SEER 15 kWh).

---

<sup>1</sup> Ameren Missouri’s 2011 IRP can be found here:  
<http://www.ameren.com/sites/ae/Environment/Renewables/Pages/IntegratedResourcePlan.aspx>

4. Incremental cost calculation. This is typically calculated as the difference between the full cost of the efficient measure and the Net Present Value of the Standard/Code baseline equipment. The Standard/Code measure will be installed at the expiration of the remaining useful life of the existing equipment (in the previous example, 6 years from today).

Evaluating the incremental costs associated with lighting measures in cases where the efficient technology has a longer life than the baseline measure being replaced also deserves a brief discussion. An example of this is a Compact Fluorescent Light (CFL) bulb. A CFL lasts 9 years, while a conventional incandescent light bulb only lasts 2 years. This differential in lifetimes indicates that the incandescent bulb would actually need to be replaced 4 times over the life of the CFL. Furthermore, Energy Independence & Security Act (EISA) has implications on the baseline technology, eliminating conventional incandescent bulbs and instilling new, more efficient bulbs. As mentioned in the section entitled, “Legislative Impacts” new halogen bulbs will likely be the baseline, and each bulb was assumed to cost \$2 (based off of primary market data collected by Ameren Missouri’s contractors). By comparing the net present value of the CFL bulb installed today (\$3.00), with the Net Present Value (NPV) of the lifetime of incandescent replacements (\$6.57), the incremental cost is actually negative as the efficient measure is cheaper than the baseline unit. Table 1 demonstrates the lifetime financial savings continually replacing incandescent light bulbs over the life of the CFL exceed the present value of the cost of the CFL.

**Table 1 Incremental Cost for Lighting Measures**

	NPV	2012	2013	2014	2015	2016	2017	2018	2019	2020
Efficient (CFL)	\$3.00	\$ 3.0								
Base (Incandescent EISA compliant)	\$6.57	\$ 0.5	\$ 0.5	\$ 2.0	\$ 0.0	\$ 2.0	\$ 0.0	\$ 2.0	\$ 0.0	\$ 2.0

The following sections identify various energy efficiency measures for both the residential and commercial and industrial end-users. The values expressed represent Ameren Missouri’s best effort to utilize Missouri specific data and where this type of data was not readily available, national best practices.

### Protocol for Deeming Measures Not Found Within TRM

If a measure or technology is discovered to yield energy and demand savings and is not found within this TRM, the following process will be followed to deem measure level energy and demand savings, incremental costs, and effective useful life. While it may be possible there are energy efficiency measures not contained within this TRM, it is unlikely those measures will have significant contributions to the portfolio savings.

1. The following information will be distributed to the appropriate stakeholders for a 2 week review and commenting period.
  - Measure level description (i.e. what the technology does, the efficiency level of the new measure and the baseline efficiency level of the existing technology);
  - Measure level energy and demand savings (and any equations that may be used to calculate those savings);
  - Measure level incremental costs;
  - Effective useful life;
  - All applicable studies, databases, reports, papers, or other supporting documentation and workpapers that inform each assumption for the proposed measure(s).
2. The appropriate EMV consultant will be asked to review inputs and calculation methodologies to assess reasonableness.
3. At the end of the two week period, a conference call will be held to solidify each measure level assumption (majority vote wins).

The TRM will be updated with the new measure value and the new measure will be used prospectively.

## **Residential Energy Efficiency Measures**

### **Residential Lighting**

The energy and demand savings for each residential lighting measure can be calculated using the following formulae:

It should also be noted that efficient lighting also impacts heating loads. The following equation can be used to estimate interactive effects for increased heating.

## Appendix A – Technical Resource Manual

## Ameren Missouri

LED Dimmable Light Bulb	12	25	Incandescent Dimmable Bulb	60.7	2.7 <sup>9</sup>	48	0	\$32.97
LED Flood PAR30 Bulb POST-EISA	15	25	Incandescent Flood Light Bulb	50.5	2.7 <sup>9</sup>	35	0	\$5.97
LED Flood PAR38 Bulb POST-EISA	18	25	Incandescent Flood Light Bulb	50.5	2.7 <sup>9</sup>	32	0	\$7.97
LED Globe G25 Bulb	8	25	Incandescent Globe Light Bulb	40.5	2.7 <sup>9</sup>	32	0	\$22.97
Metal Halide Outdoor Lighting	35	15	Incandescent Outdoor Lighting	100	8 <sup>3</sup>	189.8 <sup>3</sup>	0	\$112.00
Occupancy Sensor	N/A	10	No Sensor	N/A	N/A	217 <sup>3</sup>	0.04 <sup>7</sup>	\$61.00
CFL PRE-EISA for Multifamily	13.5 <sup>1</sup>	9 <sup>1</sup>	Incandescent Bulb	59.1	2.91 <sup>1</sup>	48.4 <sup>1</sup>	0.0075 <sup>11</sup>	\$0.00
CFL POST-EISA for Multifamily	13	9	EISA Compliant Bulb	45	2.7 <sup>11</sup>	31.5	0.00256	\$0.00
Airtight Can Bulb for Multifamily <sup>3,12</sup>	N/A	15	Standard Can Light Bulb	N/A	N/A	85	0.03	\$150.00

[1] Based on PY 2 EMV results

[2] Actual coincident demand impacts are derived using end-use load shapes that are also used for forecasting purposes

[3] Taken from Morgan Measure Libraries

[4] Incremental Cost is Negative when the Present Value of the Base and Efficient are compared

[5] Assumptions from OSRAM SYLVANIA website on HID lighting

[6] Morgan was edited to include HID data from GEP. This demand came from the loadshape since it was not accounted for in Morgan.

[7] Morgan was edited to include Sensor data from Cadmus. This demand came from the loadshape since Morgan did not account for it.

[8] Assumed same hours of use as listed in Morgan for Metal Halide Outdoor

[9] Assumed same hours of use as listed in Morgan for CFLs

[10] Based on numbers from Applied Proactive Technologies

[11] Assumed same parameter as comparable 13W CFLs for single families

[12] Assumed 6 can lights per measure

## Residential HVAC Applications

To most accurately calculate HVAC savings, building simulation modeling should be conducted (see section Building Simulation Protocols). However, if the resources to conduct building simulation do not exist, the following values can be used.

HVAC applications can either be applied as an “early replacement” or as a “replace on fail”. A “replace on fail” analysis is relatively simple, when contrasted with an “early replacement” analysis, as the analysis is a calculation of the energy and demand savings associated with the use of the efficient equipment when compared with the base equipment energy. In addition, the incremental cost for using the efficient equipment is the difference between the cost of the installed efficient equipment versus the installed base equipment.

The “early replacement” application is a more involved analysis. In this analysis, there are two timeframes that need to be analyzed. The first is the timeframe that the existing equipment would continue to operate before reaching the end of the equipment life, or the Remaining Useful Life (RUL). During the RUL of the existing equipment, the energy and demand savings gained through the use of the efficient equipment is the difference in energy and demand consumed by the efficient versus the existing equipment. Following the RUL, the second timeframe for the operation of the existing equipment is entered where the efficient equipment will continue to operate for the remainder of the equipment’s life, or the Remaining Efficient Life (REL). The REL is the difference between the EUL of the efficient equipment and the RUL of the existing equipment. During the REL of the efficient equipment, the energy and

demand savings gained through the use of the efficient equipment is the difference in energy and demand consumed by the efficient versus the base equipment that would have been installed if the existing equipment had failed.

Finally, the determination of the incremental cost associated with the “early replacement” analysis is different than that used for a “replace on fail” analysis. In the “early replacement” analysis, the incremental cost is the difference between the Net Present Value (NPV) of the efficient equipment full install cost and the NPV of the Future Value (FV) of the base equipment full installation cost.

#### ***Early Replacement Applications***

## Appendix A – Technical Resource Manual

## Ameren Missouri

<i>Central Air Conditioner (CAC) Early Replacement</i>			
Efficient CAC Efficiency Rating <sup>1</sup>	SEER 14	SEER 15	SEER 16+
Efficient CAC Annual Energy Usage <sup>1</sup>	3,567.9 kWh	3,410.2 kWh	3,266.0 kWh
Efficient CAC Electric Demand <sup>1</sup>	2.202 kW	2.105 kW	2.016 kW
Efficient CAC Cost <sup>1</sup>	\$2,640	\$2,997	\$3,054
Estimated annual energy savings for RUL replacement (SEER 8 to Efficient Unit SEER) <sup>1</sup>	1,899.6 kWh	2,057.3 kWh	2,201.5 kWh
Estimated annual energy savings for REL replacement (SEER 13 to Efficient Unit SEER) <sup>1</sup>	408.5 kWh	566.1 kWh	710.4 kWh
Estimated demand savings for RUL	1.173 kW	1.270 kW	1.359 kW
Estimated demand savings for REL	0.252 kW	0.349 kW	0.439 kW
Early Replacement Incremental Cost	\$890	\$1,247	\$1,304
Current Installed CAC Efficiency <sup>1</sup>	SEER 8		
Current Installed CAC Annual Energy Usage <sup>1</sup>	5,467.5 kWh		
Current Installed CAC electric demand <sup>1</sup>	3.375 kW		
Existing Unit RUL <sup>1</sup>	6 years		
New Air Conditioner System EUL <sup>1</sup>	18 years		
REL after RUL <sup>1</sup>	12 years		
Baseline CAC Efficiency Rating <sup>1</sup>	SEER 13		
Baseline CAC Annual Energy Usage <sup>1</sup>	3,976.4 kWh		
Baseline CAC Electric Demand <sup>1</sup>	2.455 kW		
Baseline CAC Cost <sup>1</sup>	\$2,283		
UDR used for calculating Early Replacement Incremental Cost <sup>2</sup>	7.67%		
RDR used for calculating Early Replacement Incremental Cost	3.00%		

**Appendix A – Technical Resource Manual**
**Ameren Missouri**

[1] Taken from Morgan Measure Libraries

[2] Taken from Proctor Engineering Group

**Key Assumptions:**

- Savings and costs represent the entire unit
- Unit size = 3 ton

<i>Air Source Heat Pump – ASHP Base Unit Early Replacement</i>			
Efficient ASHP Efficiency Rating <sup>1</sup>	SEER 14	SEER 15	SEER 16+
Efficient ASHP Annual Energy Usage <sup>1</sup>	11,748 kWh	11,267 kWh	10,824 kWh
Efficient ASHP Electric Demand <sup>1</sup>	2.202 kW	2.105 kW	2.016 kW
Efficient ASHP Cost <sup>1</sup>	\$3,246	\$3,357	\$3,768
Estimated annual energy savings for RUL replacement (SEER 8 to Efficient Unit SEER) <sup>1</sup>	4,201.5 kWh	4,682.6 kWh	5,125.8 kWh
Estimated annual energy savings for REL replacement (SEER 13 to Efficient Unit SEER) <sup>1</sup>	1,157.5 kWh	1,638.6 kWh	2,081.8 kWh
Estimated demand savings for RUL	1.173 kW	1.270 kW	1.359 kW
Estimated demand savings for REL	0.252 kW	0.349 kW	0.439 kW
Early Replacement Incremental Cost	\$1,073	\$1,184	\$1,595
Current Installed ASHP Efficiency <sup>1</sup>	SEER 8		
Current Installed ASHP Annual Energy Usage <sup>1</sup>	15,949.2 kWh		
Current Installed ASHP electric demand <sup>1</sup>	3.375 kW		
Existing Unit RUL <sup>1</sup>	6 years		
New ASHP EUL <sup>1</sup>	18 years		
REL after RUL <sup>1</sup>	12 years		
Baseline ASHP Efficiency Rating <sup>1</sup>	SEER 13		
Baseline ASHP Annual Energy Usage <sup>1</sup>	12,905.3 kWh		



## Appendix A – Technical Resource Manual

## Ameren Missouri

<i>Air Source Heat Pump – ASHP Base Unit Early Replacement</i>	
Baseline ASHP Electric Demand <sup>1</sup>	2.455 kW
Baseline ASHP Cost <sup>1</sup>	\$2,835
UDR used for calculating Early Replacement Incremental Cost <sup>2</sup>	7.67%
RDR used for calculating Early Replacement Incremental Cost	3.00%

[1] Taken from Morgan Measure Libraries

[2] Taken from Proctor Engineering Group

## Key Assumptions:

- Savings and costs represent the entire unit
- Unit size = 3 ton

<i>Air Source Heat Pump – Electric Resistance Base Unit Early Replacement</i>			
Efficient ASHP Efficiency Rating <sup>1</sup>	SEER 14	SEER 15	SEER 16+
Efficient ASHP Annual Energy Usage <sup>1</sup>	11,748 kWh	11,267 kWh	10,824 kWh
Efficient ASHP Electric Demand <sup>1</sup>	2.202 kW	2.105 kW	2.016 kW
Efficient ASHP Cost <sup>1</sup>	\$3,246	\$3,357	\$3,768
Estimated annual energy savings for RUL replacement (SEER 8 to Efficient Unit SEER) <sup>1</sup>	14,917 kWh	15,398 kWh	15,841 kWh
Estimated annual energy savings for REL replacement (SEER 13 to Efficient Unit SEER) <sup>1</sup>	13,426 kWh	13,907 kWh	14,350 kWh
Estimated demand savings for RUL	1.173 kW	1.270 kW	1.359 kW
Estimated demand savings for REL	0.252 kW	0.349 kW	0.439 kW
Early Replacement Incremental Cost	\$1,496	\$1,607	\$2,018
Current Installed ASHP Efficiency <sup>1</sup>	SEER 8		
Current Installed ASHP Annual Energy Usage <sup>1</sup>	26,664.5 kWh		
Current Installed ASHP electric demand <sup>1</sup>	3.375 kW		

## Appendix A – Technical Resource Manual

## Ameren Missouri

<i>Air Source Heat Pump – Electric Resistance Base Unit Early Replacement</i>	
Existing Unit RUL <sup>1</sup>	6 years
New ASHP EUL <sup>1</sup>	18 years
REL after RUL <sup>1</sup>	12 years
Baseline ASHP Efficiency Rating <sup>1</sup>	SEER 13
Baseline ASHP Annual Energy Usage <sup>1</sup>	25,173.3 kWh
Baseline ASHP Electric Demand <sup>1</sup>	2.455 kW
Baseline ASHP Cost <sup>1</sup>	\$2,283
UDR used for calculating Early Replacement Incremental Cost <sup>2</sup>	7.67%
RDR used for calculating Early Replacement Incremental Cost	3.00%

[1] Taken from Morgan Measure Libraries

[2] Taken from Proctor Engineering Group

## Key Assumptions:

- Savings and costs represent the entire unit
- Unit size = 3 ton

<i>Ground Source Heat Pump Early Replacement</i>		
Efficient Ground Source Heat Pump Efficiency Rating <sup>1</sup>	SEER 14+ Replace ASHP	SEER 14+ Replace CAC w/ Elect Resist
Efficient Ground Source Heat Pump Annual Energy Usage <sup>1</sup>	10,823.5 kWh	
Efficient Ground Source Heat Pump Electric Demand <sup>1</sup>	2.016 kW	
Efficient Ground Source Heat Pump Cost <sup>1</sup>	\$7,000	
Estimated annual energy savings for RUL replacement (Installed Base to Efficient Unit SEER) <sup>1</sup>	5,125.8 kWh	15,841.0 kWh
Estimated annual energy savings for REL replacement (SEER 13 to Efficient Unit SEER) <sup>1</sup>	2,081.8 kWh	14,349.8 kWh
Estimated demand savings for RUL	1.359 kW	
Estimated demand savings for REL	0.439 kW	

## Appendix A – Technical Resource Manual

## Ameren Missouri

<i>Ground Source Heat Pump Early Replacement</i>		
Early Replacement Incremental Cost	\$4,827	\$5,250
Current Installed ASHP or CAC Efficiency <sup>1</sup>	SEER 8	
Current Installed ASHP or CAC Annual Energy Usage <sup>1</sup>	15,949.2 kWh	26,664.5 kWh
Current Installed ASHP or CAC electric demand <sup>1</sup>	3.375 kW	
Existing Unit RUL <sup>1</sup>	6 years	
New ASHP EUL <sup>1</sup>	18 years	
REL after RUL <sup>1</sup>	12 years	
Baseline ASHP Efficiency Rating <sup>1</sup>	SEER 13	
Baseline ASHP or CAC Annual Energy Usage <sup>1</sup>	12,905.3 kWh	25,173.3 kWh
Baseline ASHP or CAC Electric Demand <sup>1</sup>	2.455 kW	
Baseline ASHP or CAC Cost <sup>1</sup>	\$2,835	\$2,283
UDR used for calculating Early Replacement Incremental Cost <sup>2</sup>	7.67%	
RDR used for calculating Early Replacement Incremental Cost	3.00%	

[1] Taken from Morgan Measure Libraries

[2] Taken from Proctor Engineering Group

## Key Assumptions:

- Savings and costs represent the entire unit
- Unit size = 3 ton

## Appendix A – Technical Resource Manual

## Ameren Missouri

<i>Concept 3 Motor Installation (ECM motor, or Brushless DC motor) Early Replacement</i>		
Efficient ECM Motor Operating Mode <sup>1</sup>	Auto Fan Operation	Continuous Fan Operation
Efficient ECM Motor Annual Energy Usage <sup>1</sup>	6,851.6 kWh	7,148.0 kWh
Efficient ECM Motor Electric Demand <sup>1</sup>	3.107 kW	
Efficient ECM Motor Cost <sup>1</sup>	\$340	
Estimated annual energy savings for RUL replacement (Older Permanent Split Capacitor motor to Efficient ECM motor) <sup>1</sup>	928.6 kWh	3,596.6 kWh
Estimated annual energy savings for REL replacement (Newer Permanent Split Capacitor motor to Efficient ECM motor) <sup>1</sup>	928.570104	3,596.6 kWh
Estimated demand savings for RUL	0.268 kW	
Estimated demand savings for REL	0.268 kW	
Early Replacement Incremental Cost	\$168	
Current Installed fan motor <sup>1</sup>	PSC Motor (Permanent Split Capacitor) for 8 SEER AC	
Current Installed PSC motor Annual Energy Usage <sup>1</sup>	7,780.2 kWh	10,744.7 kWh
Current Installed PSC motor Electric Demand <sup>1</sup>	3.375 kW	
Existing PSC motor RUL <sup>1</sup>	6 years	
New motor EUL <sup>1</sup>	18 years	
REL after RUL <sup>1</sup>	12 years	
Baseline motor type <sup>1</sup>	PSC Motor (Permanent Split Capacitor) for 13 SEER AC	
Baseline PSC motor Annual Energy Usage <sup>1</sup>	7,780.20	10,744.70
Baseline PSC motor Electric Demand <sup>1</sup>	3.375 kW	
Baseline PSC motor Cost <sup>1</sup>	\$215	
UDR used for calculating Early Replacement Incremental Cost <sup>2</sup>	7.67%	
RDR used for calculating Early Replacement Incremental Cost	3.00%	

[1] Taken from Morgan Measure Libraries

[2] Taken from Proctor Engineering Group

## Appendix A – Technical Resource Manual

## Ameren Missouri

**Moderate Setback Thermostat**

Single Family	Current typical thermostat	No setback
	Minimum threshold for credit	Moderate setback
	Estimated savings credit <sup>1</sup>	543 kWh
	Estimated demand savings credit <sup>1</sup>	-0.02 kW
	Measure life <sup>1</sup>	9 years
	Incremental Cost <sup>1</sup>	\$ 73

[1] Taken from Morgan Measure Libraries

Key Assumptions:

- 1,900 square foot home

**Full Setback Thermostat**

Single Family	Current typical thermostat	No setback
	Minimum threshold for credit	Full setback
	Estimated savings credit <sup>1</sup>	753 kWh
	Estimated demand savings credit <sup>1</sup>	-0.02 kW
	Measure life <sup>1</sup>	9 years
	Incremental Cost <sup>1</sup>	\$ 63

Multifamily Unit	Current typical thermostat	No setback
	Minimum threshold for credit	Full setback
	Estimated savings credit <sup>2</sup>	234 kWh
	Estimated demand savings credit <sup>2</sup>	-0.09 kW
	Measure life <sup>1</sup>	9 years
	Incremental Cost <sup>1</sup>	\$ 63

[1] Taken from Morgan Measure Libraries

[2] Taken from Ameren Missouri PY 2 EMV reports

Key Assumptions:

- Single Family Dwelling Area: 1,900 square feet
- Multifamily Dwelling Area: 1,000 square feet

**Energy Star Room AC**

Single Family	Current typical CAC market	9.8 EER
	Minimum threshold for credit	10.8 EER Energy Star Room AC
	Estimated savings credit <sup>1</sup>	115 kWh
	Estimated demand savings credit <sup>2</sup>	0.094 kW
	Measure life <sup>2</sup>	12 years
	Incremental Cost <sup>2</sup>	\$ 50

Multifamily Unit	Current typical CAC market	9.8 EER
	Minimum threshold for credit	Energy Star Room AC
	Estimated savings credit <sup>1</sup>	273 kWh
	Estimated demand savings credit <sup>1</sup>	0.29 kW
	Measure life <sup>2</sup>	12 years
	Incremental Cost <sup>2</sup>	\$ 50

## Appendix A – Technical Resource Manual

## Ameren Missouri

Multifamily Unit	Current typical CAC market	10.8 EER
	Minimum threshold for credit	Energy Star Room thru-wall AC
	Estimated savings credit <sup>3</sup>	274 kWh
	Estimated demand savings credit <sup>1</sup>	0.29 kW
	Measure life <sup>2</sup>	12 years
	Incremental Cost <sup>2</sup>	\$ 50

[1] Taken from Ameren Missouri PY 2 EMV reports

[2] Taken from Morgan Measure Libraries

[3] Taken from Ameren Missouri Implementation Team of Residential HVAC program

### Air Source Heat Pump SEER 14 Replace on Fail

Single Family	Current typical ASHP	ASHP SEER 13
	Minimum threshold for credit	ASHP SEER 14
	Estimated savings credit <sup>1</sup>	1,157 kWh
	Estimated demand savings credit <sup>1</sup>	0.3 kW
	Measure life <sup>1</sup>	18 years
	Incremental Cost <sup>1</sup>	\$ 411

Single Family	Current typical CAC	Electric Resistance Furnace SEER 13
	Minimum threshold for credit	ASHP SEER 14
	Estimated savings credit <sup>1</sup>	13,426 kWh
	Estimated demand savings credit <sup>1</sup>	0.3 kW
	Measure life <sup>1</sup>	18 years
	Incremental Cost <sup>1</sup>	\$ 963

Multifamily Unit	Current typical CAC	Electric Resistance Furnace SEER 13
	Minimum threshold for credit	ASHP SEER 14
	Estimated savings credit <sup>2</sup>	244 kWh
	Estimated demand savings credit <sup>2</sup>	0.32 kW
	Measure life <sup>2</sup>	12 years
	Incremental Cost <sup>2</sup>	\$ 147

[1] Taken from Proctor Engineering Group

[2] Taken from Morgan Measure Libraries

#### Key Assumptions:

- Single Family Tons = 3.0, Multifamily Tons = 1.5
- Equivalent Full Load Hours (EFLH) Cooling = 1215 (Used by Proctor Engineering Group in their calculations - Sourced from DOE, EPA, Energy Star Calculation Sheet)
- EFLH Heating = 2009 (Used by Proctor Engineering Group in their calculations - Sourced from DOE, EPA, Energy Star Calculation Sheet)

## Appendix A – Technical Resource Manual

## Ameren Missouri

*Air Source Heat Pump SEER 15 Replace on Fail*

Single Family	Current typical ASHP	ASHP SEER 13
	Minimum threshold for credit	ASHP SEER 15
	Estimated savings credit <sup>1</sup>	1,639 kWh
	Estimated demand savings credit <sup>1</sup>	0.3 kW
	Measure life <sup>1</sup>	18 years
	Incremental Cost <sup>1</sup>	\$ 522

Single Family	Current typical CAC	Electric Resistance Furnace; SEER 13
	Minimum threshold for credit	ASHP SEER 15
	Estimated savings credit <sup>1</sup>	13,907 kWh
	Estimated demand savings credit <sup>1</sup>	0.3 kW
	Measure life <sup>1</sup>	18 years
	Incremental Cost <sup>1</sup>	\$ 1,074

Multifamily Unit	Current typical CAC	Electric Resistance Furnace; SEER 13
	Minimum threshold for credit	ASHP SEER 15
	Estimated savings credit <sup>2</sup>	437 kWh
	Estimated demand savings credit <sup>2</sup>	0.41 kW
	Measure life <sup>2</sup>	12 years
	Incremental Cost <sup>2</sup>	\$ 294

[1] Taken from Proctor Engineering Group

[2] Taken from Morgan Measure Libraries

## Key Assumptions:

- Single Family Tons = 3.0, Multifamily Tons = 1.5
- EFLH Cooling = 1215 (Used by Proctor Engineering Group in their calculations - Sourced from DOE, EPA, Energy Star Calculation Sheet)
- EFLH Heating = 2009 (Used by Proctor Engineering Group in their calculations - Sourced from DOE, EPA, Energy Star Calculation Sheet)

*Air Source Heat Pump SEER 16 Replace on Fail*

Single Family	Current typical ASHP	ASHP SEER 13
	Minimum threshold for credit	ASHP SEER 16
	Estimated savings credit <sup>1</sup>	2,082 kWh
	Estimated demand savings credit <sup>1</sup>	0.4 kW
	Measure life <sup>1</sup>	18 years
	Incremental Cost <sup>1</sup>	\$ 933

Single Family	Current typical CAC	Electric Resistance Furnace; SEER 13
	Minimum threshold for credit	ASHP SEER 16
	Estimated savings credit <sup>1</sup>	14,350 kWh
	Estimated demand savings credit <sup>1</sup>	0.4 kW
	Measure life <sup>1</sup>	18 years
	Incremental Cost <sup>1</sup>	\$ 1,485

## Appendix A – Technical Resource Manual

## Ameren Missouri

Multifamily Unit	Current typical CAC	Electric Resistance Furnace; SEER 13
	Minimum threshold for credit	ASHP SEER 16
	Estimated savings credit <sup>2</sup>	316 kWh
	Estimated demand savings credit <sup>2</sup>	0.30 kW
	Measure life <sup>2</sup>	12 years
	Incremental Cost <sup>2</sup>	\$ 441

[1] Taken from Proctor Engineering Group

[2] Taken from Morgan Measure Libraries

## Key Assumptions:

- Single Family Tons = 3.0, Multifamily Tons = 1.5
- EFLH Cooling = 1215 (Used by Proctor Engineering Group in their calculations - Sourced from DOE, EPA, Energy Star Calculation Sheet)
- EFLH Heating = 2009 (Used by Proctor Engineering Group in their calculations - Sourced from DOE, EPA, Energy Star Calculation Sheet)

**Air Source Heat Pump SEER 17 Replace on Fail**

Multifamily Unit	Current typical CAC	Electric Resistance Furnace; SEER 13
	Minimum threshold for credit	ASHP SEER 17
	Estimated savings credit <sup>1</sup>	414 kWh
	Estimated demand savings credit <sup>1</sup>	0.34 kW
	Measure life <sup>1</sup>	12 years
	Incremental Cost <sup>1</sup>	\$ 588

[1] Taken from Morgan Measure Libraries

## Key Assumptions:

- Multifamily Tons = 1.5

**Air Source Heat Pump SEER 18 Replace on Fail**

Multifamily Unit	Current typical CAC	Electric Resistance Furnace; SEER 13
	Minimum threshold for credit	ASHP SEER 18
	Estimated savings credit <sup>1</sup>	454 kWh
	Estimated demand savings credit <sup>1</sup>	0.36 kW
	Measure life <sup>1</sup>	12 years
	Incremental Cost <sup>1</sup>	\$ 735

[1] Taken from Morgan Measure Libraries

## Key Assumptions:

- Multifamily Tons = 1.5

**Central Air Conditioner SEER 14 Replace on Fail**

Single Family	Current typical CAC	SEER 13
	Minimum threshold for credit	SEER 14
	Estimated savings credit <sup>1</sup>	409 kWh
	Estimated demand savings credit <sup>1</sup>	0.25 kW
	Measure life <sup>1</sup>	18 years
	Incremental Cost <sup>1</sup>	\$ 357



**Appendix A – Technical Resource Manual****Ameren Missouri**

Multifamily Unit	Current typical CAC	SEER 13
	Minimum threshold for credit	SEER 14
	Estimated savings credit <sup>2</sup>	294 kWh
	Change in usage calculation	
	Estimated demand savings credit <sup>2</sup>	0.26 kW
	Measure life <sup>2</sup>	12 years
	Incremental Cost <sup>2</sup>	\$ 139

[1] Taken from Proctor Engineering Group

[2] Taken from Morgan Measure Libraries

## Key Assumptions:

- Single Family Tons = 3.0, Multifamily Tons = 1.5
- EFLH Cooling = 1215 (Used by Proctor Engineering Group in their calculations - Sourced from DOE, EPA, Energy Star Calculation Sheet)
- EFLH Heating = 2009 (Used by Proctor Engineering Group in their calculations - Sourced from DOE, EPA, Energy Star Calculation Sheet)

**Central Air Conditioner SEER 15 Replace on Fail**

Single Family	Current typical CAC	SEER 13
	Minimum threshold for credit	SEER 15
	Estimated savings credit <sup>1</sup>	566 kWh
	Estimated demand savings credit <sup>1</sup>	0.35 kW
	Measure life <sup>1</sup>	18 years
	Incremental Cost <sup>1</sup>	\$ 714

Multifamily Unit	Current typical CAC	SEER 13
	Minimum threshold for credit	SEER 15
	Estimated savings credit <sup>2</sup>	310 kWh
	Estimated demand savings credit <sup>2</sup>	0.28 kW
	Measure life <sup>2</sup>	12 years
	Incremental Cost <sup>2</sup>	\$ 278

[1] Taken from Proctor Engineering Group

[2] Taken from Morgan Measure Libraries

## Key Assumptions:

- Single Family Tons = 3.0, Multifamily Tons = 1.5
- EFLH Cooling = 1215 (Used by Proctor Engineering Group in their calculations - Sourced from DOE, EPA, Energy Star Calculation Sheet)
- EFLH Heating = 2009 (Used by Proctor Engineering Group in their calculations - Sourced from DOE, EPA, Energy Star Calculation Sheet)

## Appendix A – Technical Resource Manual

## Ameren Missouri

**Central Air Conditioner SEER 16 Replace on Fail**

Single Family	Current typical CAC	SEER 13
	Minimum threshold for credit	SEER 16
	Estimated savings credit <sup>1</sup>	710 kWh
	Estimated demand savings credit <sup>1</sup>	0.44 kW
	Measure life <sup>1</sup>	18 years
	Incremental Cost <sup>1</sup>	\$ 771

Multifamily Unit	Current typical CAC	SEER 13
	Minimum threshold for credit	SEER 16
	Estimated savings credit <sup>2</sup>	268 kWh
	Estimated demand savings credit <sup>2</sup>	0.18 kW
	Measure life <sup>2</sup>	12 years
	Incremental Cost <sup>2</sup>	\$ 417

[1] Taken from Proctor Engineering Group

[2] Taken from Morgan Measure Libraries

## Key Assumptions:

- Single Family Tons = 3.0, Multifamily Tons = 1.5
- EFLH Cooling = 1215 (Used by Proctor Engineering Group in their calculations - Sourced from DOE, EPA, Energy Star Calculation Sheet)
- EFLH Heating = 2009 (Used by Proctor Engineering Group in their calculations - Sourced from DOE, EPA, Energy Star Calculation Sheet)

**Central Air Conditioner SEER 17 Replace on Fail**

Multifamily Unit	Current typical CAC	SEER 13
	Minimum threshold for credit	SEER 17
	Estimated savings credit <sup>1</sup>	401 kWh
	Estimated demand savings credit <sup>1</sup>	0.32 kW
	Measure life <sup>1</sup>	12 years
	Incremental Cost <sup>1</sup>	\$ 556

[1] Taken from Morgan Measure Libraries

## Key Assumptions:

- Multifamily Tons = 1.5

**Concept 3 Continuous Fan Replace on Fail**

Current typical CAC	Energy Efficiency Ratio (EER) 8 with continuous fan
Minimum threshold for credit	Concept 3 blower motor w/ continuous fan
Estimated savings credit <sup>1</sup>	3,597 kWh
Estimated demand savings credit <sup>1</sup>	0.27 kW
Measure life <sup>1</sup>	15 years
Incremental Cost <sup>1</sup>	\$ 125

**Appendix A – Technical Resource Manual****Ameren Missouri**

[1] Taken from Proctor Engineering Group

Key Assumptions:

- EFLH Cooling = 1215 (Used by Proctor Engineering Group in their calculations - Sourced from DOE, EPA, Energy Star Calculation Sheet)
- EFLH Heating = 2009 (Used by Proctor Engineering Group in their calculations - Sourced from DOE, EPA, Energy Star Calculation Sheet)

**Concept 3 Auto Fan Replace on Fail**

Current typical CAC	EER 8 with auto fan
Minimum threshold for credit	Concept 3 blower motor with auto fan
Estimated savings credit <sup>1</sup>	929 kWh
Estimated demand savings credit <sup>1</sup>	0.27 kW
Measure life <sup>1</sup>	15 years
Incremental Cost <sup>1</sup>	\$ 125

[1] Taken from Proctor Engineering Group

Key Assumptions:

- EFLH Cooling = 1215 (Used by Proctor Engineering Group in their calculations - Sourced from DOE, EPA, Energy Star Calculation Sheet)
- EFLH Heating = 2009 (Used by Proctor Engineering Group in their calculations - Sourced from DOE, EPA, Energy Star Calculation Sheet)

**Dual Fuel Heat Pump (DFHP) SEER 14 Replace on Fail**

Single Family	Current typical DFHP	SEER 13; 78 Annual Fuel Utilization Efficiency ( AFUE)
	Minimum threshold for credit	SEER 14
	Estimated savings credit <sup>1</sup>	650 kWh
	Estimated demand savings credit <sup>1</sup>	0.76 kW
	Measure life <sup>1</sup>	12 years
	Incremental Cost <sup>1</sup>	\$ 254

Multifamily Unit	Current typical DFHP	SEER 13; 78 AFUE
	Minimum threshold for credit	SEER 14
	Estimated savings credit <sup>1</sup>	302 kWh
	Estimated demand savings credit <sup>1</sup>	0.32 kW
	Measure life <sup>1</sup>	12 years
	Incremental Cost <sup>1</sup>	\$ 139

[1] Taken from Morgan Measure Libraries

Key Assumptions

- Single Family Tons = 2.7, Multifamily Tons = 1.5

## Appendix A – Technical Resource Manual

## Ameren Missouri

**Dual Fuel Heat Pump SEER 15 Replace on Fail**

Single Family	Current typical DFHP	SEER 13; 78 AFUE
	Minimum threshold for credit	SEER 15
	Estimated savings credit <sup>1</sup>	1,230 kWh
	Estimated demand savings credit <sup>1</sup>	0.80 kW
	Measure life <sup>1</sup>	12 years
	Incremental Cost <sup>1</sup>	\$ 508

Multifamily Unit	Current typical DFHP	SEER 13; 78 AFUE
	Minimum threshold for credit	SEER 15
	Estimated savings credit <sup>1</sup>	590 kWh
	Estimated demand savings credit <sup>1</sup>	0.41 kW
	Measure life <sup>1</sup>	12 years
	Incremental Cost <sup>1</sup>	\$ 278

[1] Taken from Morgan Measure Libraries

## Key Assumptions

- Single Family Tons = 2.7, Multifamily Tons = 1.5

**Dual Fuel Heat Pump SEER 16 Replace on Fail**

Single Family	Current typical DFHP	SEER 13; 78 AFUE
	Minimum threshold for credit	SEER 16
	Estimated savings credit <sup>1</sup>	1,439 kWh
	Estimated demand savings credit <sup>1</sup>	0.83 kW
	Measure life <sup>1</sup>	12 years
	Incremental Cost <sup>1</sup>	\$ 763

Multifamily Unit	Current typical DFHP	SEER 13; 78 AFUE
	Minimum threshold for credit	SEER 16
	Estimated savings credit <sup>1</sup>	492 kWh
	Estimated demand savings credit <sup>1</sup>	0.30 kW
	Measure life <sup>1</sup>	12 years
	Incremental Cost <sup>1</sup>	\$ 417

[1] Taken from Morgan Measure Libraries

## Key Assumptions

- Single Family Tons = 2.7, , Multifamily Tons = 1.5

**Dual Fuel Heat Pump SEER 17 Replace on Fail**

Single Family	Current typical DFHP	SEER 13; 78 AFUE
	Minimum threshold for credit	SEER 17
	Estimated savings credit <sup>1</sup>	1,651 kWh
	Estimated demand savings credit <sup>1</sup>	0.81 kW
	Measure life <sup>1</sup>	12 years
	Incremental Cost <sup>1</sup>	\$ 1,017

**Appendix A – Technical Resource Manual****Ameren Missouri**

Multifamily Unit	Current typical DFHP	SEER 13; 78 AFUE
	Minimum threshold for credit	SEER 17
	Estimated savings credit <sup>1</sup>	667 kWh
	Estimated demand savings credit <sup>1</sup>	0.34 kW
	Measure life <sup>1</sup>	12 years
	Incremental Cost <sup>1</sup>	\$ 556

[1] Taken from Morgan Measure Libraries

## Key Assumptions

- Single Family Tons = 2.7, Multifamily Tons = 1.5

**Dual Fuel Heat Pump SEER 18 Replace on Fail**

Single Family	Current typical DFHP	SEER 13; 78 AFUE
	Minimum threshold for credit	SEER 18
	Estimated savings credit <sup>1</sup>	1,638 kWh
	Estimated demand savings credit <sup>1</sup>	0.88 kW
	Measure life <sup>1</sup>	12 years
	Incremental Cost <sup>1</sup>	\$ 1,342

Multifamily Unit	Current typical DFHP	SEER 13; 78 AFUE
	Minimum threshold for credit	SEER 18
	Estimated savings credit <sup>1</sup>	681 kWh
	Estimated demand savings credit <sup>1</sup>	0.36 kW
	Measure life <sup>1</sup>	12 years
	Incremental Cost <sup>1</sup>	\$ 734

[1] Taken from Morgan Measure Libraries

## Key Assumptions

- Single Family Tons = 2.7, Multifamily Tons = 1.5

**Duct Insulation**

Multifamily Unit	Current typical duct system	Ducts not insulated
	Minimum threshold for credit	Insulate ducts
	Estimated savings credit <sup>1</sup>	460 kWh
	Estimated demand savings credit <sup>1</sup>	0.15 kW
	Measure life <sup>1</sup>	20 years
	Incremental Cost <sup>1</sup>	\$ 528

[1] Taken from Morgan Measure Libraries

## Key Assumptions:

- 2,200 square feet

## Appendix A – Technical Resource Manual

## Ameren Missouri

**Duct Location**

Multifamily Unit	Current typical duct system	Ducts outside conditioned space
	Minimum threshold for credit	Relocate ducts
	Estimated savings credit <sup>1</sup>	852 kWh
	Estimated demand savings credit <sup>1</sup>	0.43 kW
	Measure life <sup>1</sup>	20 years
	Incremental Cost <sup>1</sup>	\$ 1,650

[1] Taken from Morgan Measure Libraries

Key Assumptions:

- 2,200 square foot home

**Duct Sealing Level 1**

Single Family	Current typical ducted air distribution system	Substantial Leakage
	Minimum threshold for credit	14% Duct leakage improvement
	Estimated savings credit <sup>1</sup>	1,352 kWh
	Estimated demand savings credit <sup>1</sup>	0.24 kW
	Measure life <sup>1</sup>	20 years
	Incremental Cost <sup>1</sup>	\$ 325

Multifamily Unit	Current typical ducted air distribution system	Substantial Leakage
	Minimum threshold for credit	20% Duct leakage improvement
	Estimated savings credit <sup>2</sup>	250 kWh
	Estimated demand savings credit <sup>2</sup>	0.08 kW
	Measure life <sup>2</sup>	18 years
	Incremental Cost <sup>2</sup>	\$ 475

[1] Taken from Proctor Engineering Group

[2] Taken from Morgan Measure Libraries

Key Assumptions:

- 2,200 square feet (for both single family and multifamily)

**Duct Sealing Level 2**

Single Family	Current typical ducted air distribution system	Substantial Leakage
	Minimum threshold for credit	50% Duct leakage improvement
	Estimated savings credit <sup>1</sup>	2,347 kWh
	Estimated demand savings credit <sup>1</sup>	0.42 kW
	Measure life <sup>1</sup>	20 years
	Incremental Cost <sup>1</sup>	\$ 325

Multifamily Unit	Current typical ducted air distribution system	Substantial Leakage
	Minimum threshold for credit	25% Duct leakage improvement
	Estimated savings credit <sup>2</sup>	338 kWh
	Estimated demand savings credit <sup>2</sup>	0.10 kW
	Measure life <sup>2</sup>	18 years
	Incremental Cost <sup>2</sup>	\$ 475

**Appendix A – Technical Resource Manual****Ameren Missouri**

[1] Taken from Proctor Engineering Group

[2] Taken from Morgan Measure Libraries

Key Assumptions:

- 2,200 square feet (for both single family and multifamily)

**Duct Sealing Level 3**

Multifamily Unit	Current typical ducted air distribution system	Substantial Leakage
	Minimum threshold for credit	30% Duct leakage improvement
	Estimated savings credit <sup>2</sup>	424 kWh
	Estimated demand savings credit <sup>2</sup>	0.13 kW
	Measure life <sup>2</sup>	18 years
	Incremental Cost <sup>2</sup>	\$ 475

[1] Taken from Proctor Engineering Group

[2] Taken from Morgan Measure Libraries

Key Assumptions:

- 2,200 square feet

**Electronically Commutated Motor Blower – Continuous**

Multifamily Unit	Current typical motor	Standard motor continuous operation
	Minimum threshold for credit	Continuous ECM blower
	Estimated savings credit <sup>1</sup>	794 kWh
	Estimated demand savings credit <sup>1</sup>	0.14 kW
	Measure life <sup>1</sup>	15 years
	Incremental Cost <sup>1</sup>	\$ 263

[1] Taken from Morgan Measure Libraries

Key Assumptions:

- Multifamily Tons = 1.5

**Electronically Commutated Motor Blower – Intermittent**

Multifamily Unit	Current typical motor	Standard motor continuous operation
	Minimum threshold for credit	Intermittent ECM blower
	Estimated savings credit <sup>1</sup>	190 kWh
	Estimated demand savings credit <sup>1</sup>	0.11 kW
	Measure life <sup>1</sup>	15 years
	Incremental Cost <sup>1</sup>	\$ 263

[1] Taken from Morgan Measure Libraries

Key Assumptions:

- Multifamily Tons = 1.5

## Appendix A – Technical Resource Manual

## Ameren Missouri

### Ground Source Heat Pump SEER 14 Replace on Fail

Current typical heating equipment	Electric Resistance Furnace SEER 13
Minimum threshold for credit	Ground Source Heat Pump SEER 14
Estimated savings credit <sup>1</sup>	14,350 kWh
Estimated demand savings credit <sup>1</sup>	0.44 kW
Measure life <sup>1</sup>	18 years
Incremental Cost <sup>1</sup>	\$ 4,717

[1] Taken from Proctor Engineering Group

#### Key Assumptions

- Tons = 3.0

### Heat Pump Strip Heat Lock Out Installed

Current typical heat pump system	No heat pump control dial installed
Minimum threshold for credit	Heat pump strip control dial installed
Estimated savings credit <sup>1</sup>	1,332 kWh
Estimated demand savings credit <sup>1</sup>	0.47 kW
Measure life <sup>1</sup>	15 years
Incremental Cost <sup>1</sup>	\$ 154

[1] Taken from Proctor Engineering Group

#### Key Assumptions

- Tons = 3.0

### Heat Pump Strip Heat Lock Out Reset

Current typical heat pump system	Heat pump control dial installed, but not set
Minimum threshold for credit	Heat pump strip lock out installed
Estimated savings credit <sup>1</sup>	1,332 kWh
Estimated demand savings credit <sup>1</sup>	0.47 kW
Measure life <sup>1</sup>	15 years
Incremental Cost <sup>1</sup>	\$ 25

[1] Taken from Proctor Engineering Group

#### Key Assumptions

- Tons = 3.0

### HVAC Maintenance and Tune-Up

Single Family	Current typical HVAC system	10% EER degradation; 5% furnace efficiency degradation
	Minimum threshold for credit	HVAC maintenance and tune-up
	Estimated savings credit <sup>1</sup>	174 kWh
	Estimated demand savings credit <sup>1</sup>	0.21 kW
	Measure life <sup>1</sup>	10 years
	Incremental Cost <sup>1</sup>	\$ 130



## Appendix A – Technical Resource Manual

## Ameren Missouri

Multifamily Unit	Current typical HVAC system	10% EER degradation; 5% furnace efficiency degradation
	Minimum threshold for credit	HVAC maintenance and tune-up
	Estimated savings credit <sup>1</sup>	75 kWh
	Estimated demand savings credit <sup>1</sup>	0.09 kW
	Measure life <sup>1</sup>	10 years
	Incremental Cost <sup>1</sup>	\$ 70

[1] Taken from Morgan Measure Libraries

### Key Assumptions

- Single Family Tons = 2.7, Multifamily Tons = 1.5

### Indoor Coil Cleaning

Current typical air conditioning or heat pump system	Dirty coils
Minimum threshold for credit	Coil cleaning
Estimated savings credit <sup>1</sup>	638 kWh
Estimated demand savings credit <sup>1</sup>	0.23 kW
Measure life <sup>1</sup>	5 years
Incremental Cost <sup>1</sup>	\$ 63

[1] Taken from Proctor Engineering Group

### Key Assumptions

- Tons = 3.0

### Outdoor Coil Cleaning

Current typical air conditioning or heat pump system	Dirty coils
Minimum threshold for credit	Coil cleaning
Estimated savings credit <sup>1</sup>	515 kWh
Estimated demand savings credit <sup>1</sup>	0.18 kW
Measure life <sup>1</sup>	5 years
Incremental Cost <sup>1</sup>	\$ 31

[1] Taken from Proctor Engineering Group

### Key Assumptions

- Tons = 3.0

### Packaged Terminal Air Conditioner (PTAC) EER 9.3 Replace on Fail

Current typical PTAC	EER 7.1
Minimum threshold for credit	EER 9.3
Estimated savings credit <sup>1</sup>	213 kWh
Estimated demand savings credit <sup>1</sup>	0.20 kW
Measure life <sup>1</sup>	15 years
Incremental Cost <sup>1</sup>	\$ 136

[1] Taken from Morgan Measure Libraries

### Key Assumptions

- Tons = 0.8

**Appendix A – Technical Resource Manual****Ameren Missouri****Packaged Terminal Air Conditioner EER 10.3 Replace on Fail**

Current typical PTAC	EER 8.7
Minimum threshold for credit	EER 10.3
Estimated savings credit <sup>1</sup>	133 kWh
Estimated demand savings credit <sup>1</sup>	0.11 kW
Measure life <sup>1</sup>	15 years
Incremental Cost <sup>1</sup>	\$ 124

[1] Taken from Morgan Measure Libraries

## Key Assumptions

- Tons = 0.8

**Packaged Terminal Heat Pump (PTHP) EER 9.1 Replace on Fail**

Current typical PTHP	EER 7.0
Minimum threshold for credit	EER 9.1
Estimated savings credit <sup>1</sup>	336 kWh
Estimated demand savings credit <sup>1</sup>	0.20 kW
Measure life <sup>1</sup>	15 years
Incremental Cost <sup>1</sup>	\$ 169

[1] Taken from Morgan Measure Libraries

## Key Assumptions

- Tons = 0.8

**Packaged Terminal Heat Pump EER 10.9 Replace on Fail**

Current typical PTHP	EER 8.5
Minimum threshold for credit	EER 10.9
Estimated savings credit <sup>1</sup>	244 kWh
Estimated demand savings credit <sup>1</sup>	0.15 kW
Measure life <sup>1</sup>	15 years
Incremental Cost <sup>1</sup>	\$ 155

[1] Taken from Morgan Measure Libraries

## Key Assumptions

- Tons = 0.8

**Refrigerant Charge Adjustment**

Single Family	Current typical system	10% EER degradation
	Minimum threshold for credit	Correct charge
	Estimated savings credit <sup>1</sup>	191 kWh
	Estimated demand savings credit <sup>1</sup>	0.23 kW
	Measure life <sup>1</sup>	10 years
	Incremental Cost <sup>1</sup>	\$ 127

## Appendix A – Technical Resource Manual

## Ameren Missouri

Multifamily	Current typical system	5% EER degradation
	Minimum threshold for credit	Correct charge
	Estimated savings credit <sup>1</sup>	44 kWh
	Estimated demand savings credit <sup>1</sup>	0.06 kW
	Measure life <sup>1</sup>	10 years
	Incremental Cost <sup>1</sup>	\$ 58

Multifamily	Current typical system	10% EER degradation
	Minimum threshold for credit	Correct charge
	Estimated savings credit <sup>1</sup>	87 kWh
	Estimated demand savings credit <sup>1</sup>	0.12 kW
	Measure life <sup>1</sup>	10 years
	Incremental Cost <sup>1</sup>	\$ 70

Multifamily	Current typical system	15% EER degradation
	Minimum threshold for credit	Correct charge
	Estimated savings credit <sup>1</sup>	131 kWh
	Estimated demand savings credit <sup>1</sup>	0.18 kW
	Measure life <sup>1</sup>	10 years
	Incremental Cost <sup>1</sup>	\$ 219

[1] Taken from Morgan Measure Libraries

## Key Assumptions

- Tons = 2.7

**Air Sealing (Infiltration Reduction) Level 1**

Current typical system	Varies by vintage
Minimum threshold for credit	Reduce air leakage 30%
Estimated savings credit <sup>1</sup>	448 kWh
Estimated demand savings credit <sup>1</sup>	0.07 kW
Measure life <sup>1</sup>	13 years
Incremental Cost <sup>1</sup>	\$ 264

[1] Taken from Morgan Measure Libraries

## Key Assumptions

- Tons = 2.2

**Air Sealing (Infiltration Reduction) Level 2**

Current typical system	Varies by vintage
Minimum threshold for credit	Reduce air leakage 50%
Estimated savings credit <sup>1</sup>	740 kWh
Estimated demand savings credit <sup>1</sup>	0.12 kW
Measure life <sup>1</sup>	13 years
Incremental Cost <sup>1</sup>	\$ 264

[1] Taken from Morgan Measure Libraries

Key Assumptions

- Tons = 2.2

## **Residential Appliances**

### ***Appliance Recycling***

Ameren Missouri considered 3 measures for an Appliance Recycling program. All 3 measures were associated with different residential end uses: refrigeration, freezer, and miscellaneous. These measures are different than other measures in the TRM because the efficient characteristics assume a complete removal of the base characteristic. The incremental cost for each appliance recycling measure is the actual cost associated with the removal and recycling of the retired unit.

The energy and demand savings for the freezer and refrigerator recycling measures can be calculated using the following formula:

**Appendix A – Technical Resource Manual****Ameren Missouri**

The Energy Star refrigerator measure is associated with the residential refrigeration end use. The energy savings equation was taken from Ameren Missouri's PY 2 EMV reports. The following table summarizes the measure level energy savings, demand savings, incremental cost, and effective useful life.

Current typical existing market (baseline)	Operating unit with top freezer (15, 18, or 21 ft <sup>3</sup> ) manufactured before 2000
Minimum threshold for credit	Energy Star Refrigerator in Multifamily Unit
Estimated savings credit for Energy Star Refrigerator <sup>1</sup>	1,126 kWh
Change in usage calculation <sup>1</sup>	
Estimated demand savings credit for installing Energy Star Refrigerator <sup>1</sup>	0.1778 kW
Measure life	10 years
Incremental Cost <sup>1</sup>	\$ 680

[1] Taken from Ameren Missouri PY 2 EMV Report

\*- If the appropriate field data required to complete this equation cannot be obtained, the deemed savings values in the table are to be used for each measure.

**Key Assumptions**

- Base UEC = 1,495 kWh
- Efficient UEC = 369 kWh

Note, this savings value is only for multi-family units, savings for single family units, while similar, may be slightly different due to various factors including as household size, location of unit, or climate. Another tool to help estimate savings is the Energy Star website which provides various unit models and associated energy consumption.

[http://www.energystar.gov/index.cfm?fuseaction=find\\_a\\_product.showProductGroup&pgw\\_code=RF](http://www.energystar.gov/index.cfm?fuseaction=find_a_product.showProductGroup&pgw_code=RF)

**Energy Star Freezer**

The Energy Star freezer measure is associated with the residential refrigeration end use. The energy savings equation was taken from Ameren Missouri's PY 2 EMV reports. The following table summarizes the measure level energy savings, demand savings, incremental cost, and effective useful life.

Current typical existing market (baseline)	Standard Freezer
Minimum threshold for credit	Energy Star Freezer
Estimated savings credit for Energy Star Freezer <sup>1</sup>	61 kWh
Estimated demand savings credit for installing Energy Star Freezer <sup>1</sup>	0.004 kW
Measure life <sup>1</sup>	11 years
Incremental Cost <sup>1</sup>	\$ 33

[1] Taken from Ameren Missouri PY 2 EMV Report

**Energy Room Air Purifier**

The Energy Star air purifier measure is associated with the residential miscellaneous end use. The energy savings equation was taken from Ameren Missouri's PY 3 EMV reports. The following table summarizes the measure level energy savings, demand savings, incremental cost, and effective useful life.

## Appendix A – Technical Resource Manual

## Ameren Missouri

<u>Current typical existing market (baseline)</u>	<u>Standard Air Purifier</u>
<u>Minimum threshold for credit</u>	<u>Energy Star Air Purifier</u>
<u>Estimated savings credit for Energy Star Air Purifier<sup>1</sup></u>	<u>482 kWh</u>
<u>Estimated demand savings credit for installing Energy Star Air Purifier<sup>1</sup></u>	<u>0.0813 kW</u>
<u>Measure life<sup>1</sup></u>	<u>9 years</u>
<u>Incremental Cost<sup>1</sup></u>	<u>\$ 70</u>

[1] Taken from Ameren Missouri PY 3 EMV Report. Updated calculations using Air Purifier Energy Star calculator.

Key Assumptions:

- Unit Size = CADR(clean air delivery rate)

<u>CADR</u>	<u>Annual Energy Savings (kWh)</u>	<u>Qty</u>	<u>Weight</u>
<u>51-100 (75)</u>	<u>293</u>	<u>352</u>	<u>34%</u>
<u>101-150 (125)</u>	<u>488</u>	<u>508</u>	<u>48%</u>
<u>151-200 (175)</u>	<u>683</u>	<u>117</u>	<u>11%</u>
<u>201-250 (225)</u>	<u>877</u>	<u>10</u>	<u>1%</u>
<u>Over 250 (275)</u>	<u>1,072</u>	<u>61</u>	<u>6%</u>
<u>Not listed</u>	<u>482.08*</u>	<u>460</u>	<u>N/A</u>

\* Savings are the weighted average savings for the products included in the ENERGY STAR QPL.

Information taken from the Energy Star calculator found here:

[http://www.energystar.gov/index.cfm?fuseaction=find\\_a\\_product.showProductGroup&pgw\\_code=RAC](http://www.energystar.gov/index.cfm?fuseaction=find_a_product.showProductGroup&pgw_code=RAC)

Refrigerator Coil Cleaning Brush

The refrigerator coil cleaning brush is a device used to clean the coils underneath a refrigerator. This device will be initially used during the low income program by the program administrator, and subsequently left behind for customers to use.

<u>Current typical existing market (baseline)</u>	<u>No Brush</u>
<u>Minimum threshold for credit</u>	<u>Coil Cleaner Brush</u>
<u>Estimated savings credit<sup>1</sup></u>	<u>16.5 kWh</u>
<u>Estimated demand savings credit<sup>1</sup></u>	<u>0.0773 kW</u>
<u>Measure life<sup>1</sup></u>	<u>2 years</u>
<u>Incremental Cost<sup>1</sup></u>	<u>\$ 3</u>

[1] Taken from Honeywell Low Income proposal October 2012.

Key Assumptions:

- 3% of annual refrigerator annual kWh consumption
- Annual refrigerator consumption = 550 kWh based on the average Federal Standard kWh/year

Energy Star Water Cooler

The Energy Star water cooler measure is associated with the residential refrigeration end use. The energy savings equation was taken from Ameren Missouri's PY 3 EMV reports. The following table

## Appendix A – Technical Resource Manual

## Ameren Missouri

summarizes the measure level energy savings, demand savings, incremental cost, and effective useful life.

Current typical existing market (baseline)	Standard Water Cooler
Minimum threshold for credit	Energy Star Water Cooler
Estimated savings credit for Energy Star Water Cooler Cold Only <sup>1</sup>	47 kWh
Estimated savings credit for Energy Star Water Cooler Hot and Cold <sup>1</sup>	361 kWh
Estimated demand savings credit for installing Energy Star Water Cooler Cold Only <sup>1</sup>	0.233 kW
Estimated demand savings credit for installing Energy Star Water Cooler Hot and Cold <sup>1</sup>	.001 kW
Measure life <sup>1</sup>	10 years
Incremental Cost <sup>1</sup>	\$ 17

[1] Taken from Ameren Missouri PY 3 EMV Report

## Key Assumptions:

- 365 days per year
- Conventional Hot and Cold energy consumption = 2.19 kWh/day
- Conventional Cold Water Only energy consumption = 0.29 kWh per day
- Efficient Hot and Cold energy consumption = 1.2 kWh per day.
- Efficient Cold Water Only energy consumption = 0.16 kWh per day
- Blend of hot and cold, and cold only water coolers. 98% are assumed to be combination and 2% are cold only.

Unit Type	Annual Energy Savings (kWh)	Qty	Weight
Hot and Cold	361	508	98%
Cold only*	47	9	2%

\* This category includes "Cook and Cold" units.

Information taken from the Energy Star calculator found here:

[http://www.energystar.gov/index.cfm?fuseaction=find\\_a\\_product.showProductGroup&pgw\\_code=WA](http://www.energystar.gov/index.cfm?fuseaction=find_a_product.showProductGroup&pgw_code=WA)

**Smart Strip Plug Outlet**

The smart strip plug outlet measure is associated with the residential miscellaneous end use. All of the parameters for the smart strip plug outlet were taken from Morgan Measure Libraries. Morgan Measure Libraries methodology for calculating the savings for smart strips considered idle wattages for computer and television peripherals and took an average of both peripheral systems. Morgan Measure Libraries considered the computer peripherals to include: speakers, ink-jet printer, internet terminal and phone/fax/copier. Morgan Measure Libraries considered the television peripherals to include: audio system/ speakers, DVD player, VCR, cable box, and video game console.

The energy and demand savings for the smart strip measure can be calculated using the following formulae:

**Appendix A – Technical Resource Manual****Ameren Missouri**

If the appropriate field data required to complete this equation cannot be obtained, the deemed savings values in the following table are to be used for each measure.

Current typical existing market (baseline)	Standard Plug +Outlet
Minimum threshold for credit	Smart Strip Plug Outlet
Estimated savings credit for smart strip <sup>1</sup>	184 kWh
Estimated demand savings credit for installing smart strip <sup>1</sup>	0.0261 kW
Measure life	5 years
Incremental Cost <sup>1</sup>	\$ 40

[1] Taken from Morgan Measure Libraries

**Key Assumptions:**

- Idle Watts = average energy used by system when in standby mode and computer or TV is turned off
- Efficient Idle Watts = average energy used by system when in standby mode and computer or TV is turned off
- Idle Hours per day = hours per day when system is assumed to be turned off = 19.5

**Pool Pump and Motor**

The pool pump and motor measures are associated with the business motors end use. All of the parameters for the pool pump and motor measures were taken from Morgan Measure Libraries. For each of the measures steady state operation was assumed. A base case and an improved case was calculated for each measure and the power reduction was taken as the average power reduction in the case of the single speed measure or the time weighted average power reduction in the case of the dual speed measure. A coincidence factor of 50% was used for peak savings. Morgan Measure libraries assumed a swimming season duration of May 1 through September 30. Morgan Measure libraries assumed the average pool volume is 25,000 gallons.

The energy and demand savings for the smart strip measure can be calculated using the following formulae:

**Single Speed High Efficiency Pool Pump**

Current typical existing market (baseline)	Standard Pool Pump and Motor Efficiency
Minimum threshold for credit	Single Flow High Efficiency Pool Pump and Motor with Controls
Estimated savings credit for efficient pool pump <sup>1</sup>	694 kWh
Change in use calculation <sup>2</sup>	See equation below.
Estimated demand savings credit for efficient pool pump <sup>1</sup>	0.357 kW
Measure life <sup>1</sup>	10 years
Incremental Cost <sup>1</sup>	\$ 85

[1] Taken from Morgan Measure Libraries

[2] Taken from Ohio TRM 2010



\*- If the appropriate field data required to complete this equation cannot be obtained, the deemed savings values in the table are to be used for each measure.

- LFBASE = Load factor of baseline motor
- LFEff1 = Load factor of two speed motor at slow speed = 55% delta
- LFEff2 = Load factor of two speed motor at high speed = 1%delta
- $\eta$ PumpBase = Efficiency of baseline motor
- $\eta$ PumpEff1 = Efficiency of two speed motor at slow speed = 5% delta
- $\eta$ PumpEff2 = Efficiency of two speed motor at high speed = 13% delta
- AOHBase = Assumed annual operating hours of baseline pump
- AOHEff1 = Assumed annual hours of two speed pump at low speed = 918
- AOHEff2 = Assumed annual hours of two speed pump at high speed = 918
- HP1 = Pump horse power = 0.12 delta
- CF = conversion factor = 0.746
- HP2 = Pump horse power = 0.0 delta
- CF = conversion factor = 0.746

***Variable Frequency Drive (VFD) on Swimming Pool Pump***

The VFD on swimming pool pump measure is associated with the residential pool spa end use.

The energy and demand savings for the VFD on swimming pool pump measure can be calculated using the following formulae:

## Appendix A – Technical Resource Manual

## Ameren Missouri

[1]Information taken from Morgan Measure Library

### Multi Family Window Replacement

Current typical existing market (baseline)	Varies by Vintage
Minimum threshold for credit	SHGC = 0.4, U = 0.35
Estimated savings credit for efficient windows <sup>1</sup>	2,140 kWh
Estimated demand savings credit for efficient windows <sup>1</sup>	0.692 kW
Measure life <sup>1</sup>	20 years
Incremental Cost <sup>1</sup>	\$ 1,500

[1]Information taken from Morgan Measure Library

### Multi Family Window Film

Current typical existing market (baseline)	SHGC = .39; U=.72
Minimum threshold for credit	2 pane clear; SHGC = .73; U=.72
Estimated savings credit for efficient windows <sup>1</sup>	325 kWh
Estimated demand savings credit for efficient windows <sup>1</sup>	0.626 kW
Measure life <sup>1</sup>	10 years
Incremental Cost <sup>1</sup>	\$ 538

[1]Information taken from Morgan Measure Library

### Ceiling Insulation

Current typical existing market (baseline)	R-19 or below
Minimum threshold for credit	R-30 or above
Estimated savings credit <sup>1</sup>	See table below
Estimated demand savings credit <sup>1</sup>	See table below
Measure life <sup>1</sup>	25 years
Incremental Cost <sup>2</sup>	See Table Below

[1] Information taken Illinois TRM 2012.

[2] Information gathered from Missouri insulation contractors participating in Ameren Missouri's natural gas incentive program.

Efficient	Baseline	kWh	kW	Electric Incremental Cost*	Full Incremental Cost**
R-30	R-5	433.9	0.3	\$ 75	\$ 475
R-38	R-5	452.2	0.3	\$ 86	\$ 550
R-49	R-5	467.6	0.4	\$ 104	\$ 665
R-30	R-11	149.9	0.1	\$ 66	\$ 420
R-38	R-11	168.2	0.1	\$ 78	\$ 495
R-49	R-11		0.1	\$ 94	\$ 600

Formatted Table

## Appendix A – Technical Resource Manual

## Ameren Missouri

		<u>183.6</u>			
R-30	R-19	<u>50.2</u>	<u>0.0</u>	<u>\$ 54</u>	<u>\$ 345</u>
R-38	R-19	<u>68.5</u>	<u>0.1</u>	<u>\$ 66</u>	<u>\$ 420</u>
R-49	R-19	<u>83.9</u>	<u>0.1</u>	<u>\$ 82</u>	<u>\$ 525</u>

\*-This measure is intended to be included within Ameren Missouri's Home Energy Performance program. Since this program seeks to glean both electric and natural gas savings from Ameren Missouri customers receiving both fuel services from the Company, the incremental costs are parsed on a source BTU basis between natural gas and electric fuels. This is done by multiplying annual CCF savings by 100,000 and electric annual kWh savings by 10,000. As an example, ceiling insulation with a baseline of R-5 and an efficient of R-30 saves 433.9 kWh and 227.6 therms. Multiply therm savings by 1.024 to convert to CCF,  $227.5 * 1.024 = 233$ . This yields 4,339,268 source BTU electric and 23,303,097 source BTU gas, or 15.7% electric and 84.3% gas. Multiplying the full incremental cost of  $\$475 * 15.7\% = \$75$ .

\*\*-Incremental cost is assuming 950 square feet times the appropriate R-value differential in "Insulation Cost Table." These cost estimates were gathered from Missouri based insulation contractors.

## Key Assumptions

AC SEER	10	based on Illinois TRM 2012
Furnace AFUE	70%	based on Illinois TRM 2012
Baseline R-value	See Above	
Efficient R-value	See Above	
Framing factor	0.15	
Ceiling Area (sq ft)	950	based on 2009 DSM potential study home size of 1900 sq ft
Lifetime	25	years based off Illinois TRM
CDD	1646	NOAA @65 degrees @ Lambert
HDD	4535	NOAA @65 degrees @ Lambert
FLH cool	1215	based on Energy Star calculator St Louis
System Coincidence Factor	0.915	based on Illinois TRM Belleville Area
	100,067	Btu/therm

$$= [(1/R_{old} - 1/R_{attic}) * A_{attic} * (1 - \text{Framing factor}/2) * 24 * CDD] / (1000 * \eta_{Cool})$$

$R_{attic}$  = R-value of new attic assembly (including all layers between inside air and outside air).

$R_{old}$  = R-value value of existing assemble and any existing insulation. (Minimum of R-5 for uninsulated assemblies<sup>2</sup>)

$A_{attic}$  = Total area of insulated ceiling/attic (ft<sup>2</sup>)

Framing factor = Adjustment to account for area of framing  
= 15%<sup>3</sup>

<sup>2</sup> An estimate based on review of Madison Gas and Electric, Exterior Wall Insulation, R-value for no insulation in walls, and NREL's Building Energy Simulation Test for Existing Homes (BESTEST-EX).

<sup>3</sup> Based on Oak Ridge National Lab, Technology Fact Sheet for Wall Insulation. Factor is used directly for walls, but

## Appendix A – Technical Resource Manual

## Ameren Missouri

24 = Converts hours to days

CDD = Cooling Degree Days  
= dependent on location<sup>4</sup>:

1000 = Converts Btu to kBtu

nCool = Seasonal Energy Efficiency Ratio of cooling system (kBtu/kWh)  
= Actual (where it is possible to measure or reasonably estimate). If unknown assume the following<sup>5</sup>:

Age of Equipment	nCool Estimate
Before 2006	10
After 2006	13

Formatted: Indent: Left: 0.5", First line: 0.5"

Insulation Cost Table		
Starting Baseline Insulation	Upgraded Insulation	\$/sf cellulose
R-5	R-30	\$ 0.50
R-5	R-38	\$ 0.58
R-5	R-49	\$ 0.70
R-11	R-30	\$ 0.44
R-11	R-38	\$ 0.52
R-11	R-49	\$ 0.63
R-19	R-30	\$ 0.36
R-19	R-38	\$ 0.44
R-19	R-49	\$ 0.55

Formatted: Font: Bold

Formatted: Font: Bold, Not Italic

Formatted: Centered, None, Space Before: 0 pt, Don't keep with next

Formatted Table

In order to appropriately parse costs and savings, the following natural gas savings equations can be utilized.

$$= [(1/R_{old} - 1/R_{attic}) * A_{attic} * (1 - \text{Framing factor}/2) * 24 * \text{HDD}] / (100,067 * n_{Heat})$$

nHeat = Efficiency of heating system. Use actual, if unknown assume 70%.

Formatted: Indent: Left: 1"

## Residential Water Heating

### Water Heater

Water heater efficiency is rated according to its Energy Factor (EF). For residential storage tank electric water heaters, the current minimum standard requires an EF of 0.90 or greater. Heat Pump Water Heaters (HPWH) take heat from the surrounding air and transfer it to the water in the tank, unlike

reduced by 1/2 for attics, assuming that the average joist is 5.5" and R-38 requires 11" of cellulose, therefore at each joist, 1/2 the thickness of insulation has been added as between the joists.

<sup>4</sup> National Climatic Data Center, Cooling Degree Days are based on a base temp of 65°F. There is a county mapping table in the Appendix providing the appropriate city to use for each county of Illinois.

<sup>5</sup> These default system efficiencies are based on the applicable minimum Federal Standards. In 2006 the Federal Standard for Central AC was adjusted. While one would expect the average system efficiency to be higher than this minimum, the likely degradation of efficiencies over time mean that using the minimum standard is appropriate.

conventional water heaters, which use either gas (or sometimes other fuels) burners or electric resistance heating coils to heat the water. HPWH technology uses a standard heat pump thermodynamic cycle to remove energy from a low-temperature heat source (the ambient room air) and transfer it to a high-temperature heat sink (the water within the heater). Most HPWHs have back up heating elements to heat the water during very low temperature periods and come either self-contained with a storage tank or as an add-on unit using a conventional water heater for storage.

The energy and demand savings for each residential water heater measure can be calculated using the following formulae:

[1] Taken from Morgan Measure Libraries

***Water Heater Blankets***

Water heater blankets having an R value of 11 when wrapped around electric water heaters. The energy savings equation for a water heater blanket was taken from Ameren Missouri's Multifamily PY2 Report.



## Appendix A – Technical Resource Manual

## Ameren Missouri

The following table summarizes the measure level energy savings, demand savings, incremental cost, and effective useful life.

Efficient Characteristics		Base Characteristics					
Description	Measure Life	Description	$\Delta$ UA	$\Delta$ Temp (°F)	Estimated Annual Energy Savings (kWh)	Estimated Annual Demand Savings (kW)	Incremental Cost
Electric Water Heater Tank Blanket Insulation, R-5 for Single Family Dwelling <sup>1</sup>	10	Water Heater with No Insulation	1.24	56.5	180	0.02	\$18.00
Electric Water Heater Tank Blanket Insulation, R-5 for Multifamily Dwelling <sup>2</sup>	15	Water Heater with No Insulation	0.14	56.5	33	0.00	\$18.00

[1] Taken from Morgan Measure Libraries. Morgan was appended to include information from Cadmus.

[2] Based on Ameren Missouri PY 2 EMV report.

[3] Pennsylvania TRM 2012.

### Water Heater Thermostat Set-back

Current typical existing market (baseline)	Electric Water Heater Thermostat set at 135°F
Minimum threshold for credit	Electric Water Heater Thermostat set at 120°F
Estimated savings credit for water heater set-back <sup>1</sup>	163 kWh
Estimated demand savings credit for water heater set-back <sup>1</sup>	0.02 kW
Measure life <sup>1</sup>	4 years
Incremental Cost <sup>1</sup>	\$ 8

[1] Taken from Morgan Measure Libraries (Cadmus Potential Study measure list)

### Key Assumptions

- Assumes a 40 gallon residential tank

### Geothermal Heat Pump Desuperheater

The energy savings equation was taken from Morgan Measure Libraries. Morgan was appended to include information from Cadmus to include information for a geothermal heat pump desuperheater. The following table summarizes the measure level energy savings, demand savings, incremental cost, and effective useful life.

Current typical existing market (baseline)	No Desuperheater
Minimum threshold for credit	Electric Water Heater Thermostat set at 120°F
Estimated savings credit for desuperheater <sup>1</sup>	1,540 kWh
Estimated demand savings credit for efficient desuperheater <sup>1</sup>	0.17 kW
Measure life <sup>1</sup>	10 years
Incremental Cost <sup>1</sup>	\$ 239

[1] Taken from Morgan Measure Libraries (Cadmus Potential Study measure list)

***Pipe Wrap***

The energy savings equation for pipe wrap was taken from Ameren Missouri's Multifamily PY2 Report.

**Appendix A – Technical Resource Manual****Ameren Missouri**

- Days = number of days per year a shower is taken, 365
- $\Delta$ GPM = difference in gallons per minute for the base showerhead and the new showerhead
- $\Delta$ Temp = difference in temperatures of the shower water and the water main
- EF = energy factor of the water heater
- Number of Units = number of showerheads in home = 1
- 409.7 = a constant derived from  $3,413/8.33$

Note: the savings values have only been evaluated for multifamily units. It is likely there will be savings differences between multifamily and single family residences.

The following table summarizes the measure level energy savings, demand savings, incremental cost, and effective useful life.

Efficient Characteristics		Base Characteristics					
Description	Measure Life	Description	$\Delta$ GPM	$\Delta$ Temp (°F)	Estimated Annual Energy Savings (kWh)	Estimated Annual Demand Savings (kW)	Incremental Cost
Low Flow Showerhead for Single Family Dwelling <sup>1</sup>	12	Standard showerhead flow	0.75		361	0.048	\$31.60
Low Flow Showerhead for Multifamily Dwelling <sup>2</sup>	12	Standard showerhead flow	0.5	43.7	203.7	0.0	\$31.60

[1] Taken from Morgan Measure Libraries

[2] Based on PY 2 EMV results.

### **Low Flow Faucet Aerators**

The energy savings equation for low flow faucet aerator was taken from Ameren Missouri's Multifamily PY2 Report.

**Appendix A – Technical Resource Manual****Ameren Missouri**

- The following table summarizes the measure level energy savings, demand savings, incremental cost, and effective useful life.
- Annual Operating Hours = 2361.75

Efficient Characteristics		Base Characteristics					
Description	Measure Life	Description	ΔGPM	ΔTemp (°F)	Estimated Annual Energy Savings (kWh)	Estimated Annual Demand Savings (kW)	Incremental Cost
Low Flow Faucet Aerator for Single Family Dwelling <sup>1</sup>	12	Standard faucet flow of 2.2 gpm	0.7	45	57	0.016	\$9.50
Low Flow Faucet Aerator for Multifamily Dwelling <sup>2</sup>	12	Standard showerhead flow of 2.2 gpm	0.7	18.7 <sup>3</sup>	37.2	0.0	\$9.50

[1] Taken from Morgan Measure Libraries

[2] Based on Ameren Missouri PY 2 EMV report.

[3] Assume faucet outlet temperature is 80°F according to 2009 Vermont TRM. Assume cold water inlet temperature for St. Louis, MO is 61.3°F according to <http://www.gfxtechnology.com/WaterTemp.pdf>

## Commercial and Industrial Energy Efficiency Measures

### Commercial Lighting

Interior Lighting Operating Hours by Building Type		
Building Type	Annual Hours	Building Mix Weighting**
Assembly	5,397	4.2%
Big Box Retail	6,439	4.0%
Fast Food Restaurant	6,492	2.4%
Full Service Restaurant	4,850	1.2%
Grocery	6,702	6.2%
Hospital	3,758	5.9%
Hotel	8,760*	1.7%
Large Office	5,571	11.3%
Light Industrial	5,594	43.0%
Primary School	3,149	7.2%
Small Office	4,342	5.6%
Small Retail	4,883	2.0%
Warehouse	5,063	5.3%
Weighted Average	5,202	100%

**Appendix A – Technical Resource Manual****Ameren Missouri**

Source: From Ameren Missouri PY 2 EMV report conducted by ADM Associates, Inc. 2011  
 \*Non-Guest Room  
 \*\* Weights taken from Morgan Measure Database

**Commercial Lighting 3-Lamp T5 Fluorescent Lighting Fixture Replacing 250 watt HID**

Current typical existing lighting market (baseline)	High Bay High Intensity Discharge (HID) – Metal Halide 250 W
Minimum threshold for credit	T5 High-output fluorescent lamps
Estimated savings credit for installing T5 High-Output <sup>1</sup>	449 kWh (per fixture)
Change in usage calculation <sup>2</sup>	$\Delta\text{kWh} = ((\text{WATTS}_{\text{base}} - \text{WATTS}_{\text{ee}}) * \text{HOURS} * \text{IF}) / 1000^*$
Estimated demand savings credit for installing T5 High-Output <sup>1</sup>	0.103 kW (per fixture)
Measure life	12 years
Incremental Cost <sup>1</sup>	\$ 180

[1] Taken from Morgan Measure Libraries

[2] Taken from Ohio TRM 2009

\*- If the appropriate field data required to complete this equation cannot be obtained, the deemed savings values in the table are to be used for each measure.

## Key Assumptions:

- Coincidence Factor (CF) = 0.95
- IF = Interactive Factor = 1.0 (assumed to be 1 for the first 3 year implementation program until further data can be gathered and consensus can be built).
- $\text{WATTS}_{\text{base}}$  = Power draw (expressed in Watts) of base (existing) interior electrical equipment = 290 watts
- $\text{WATTS}_{\text{ee}}$  = Power draw (expressed in Watts) of efficient (replacement) electrical equipment = 182 watts
- HOURS = annual operating hours= 4,160 (lighting hour estimate taken from Morgan Measure Libraries)

**Commercial Lighting 4-Lamp T5 Fluorescent Lighting Fixture Replacing 400 watt Metal Halide**

Current typical existing lighting market (baseline)	High Bay HID – Metal Halide 400 W
Minimum threshold for credit	T5 High-output fluorescent lamps
Estimated savings credit for installing T5 High-Output <sup>1</sup>	1180.8 kWh (per fixture)
Change in usage calculation <sup>2</sup>	$\Delta\text{kWh} = ((\text{WATTS}_{\text{base}} - \text{WATTS}_{\text{ee}}) * \text{HOURS} * \text{IF}) / 1000^*$
Estimated demand savings credit for installing T5 High-Output <sup>1</sup>	0.21 kW (per fixture)
Measure life	11 years
Incremental Cost <sup>1</sup>	\$ 339

[1] Taken from EMV PY 2 analysis

[2] Taken from Ohio TRM 2009

**Appendix A – Technical Resource Manual****Ameren Missouri**

\*- If the appropriate field data required to complete this equation cannot be obtained, the deemed savings values in the table are to be used for each measure.

## Key Assumptions:

- Coincidence Factor (CF) = 0.95
- IF = Interactive Factor = 1.0 (assumed to be 1 for the first 3 year implementation program until further data can be gathered and consensus can be built).
- WATTS<sub>base</sub> = Power draw (expressed in Watts) of base (existing) interior electrical equipment = 470 watts
- WATTS<sub>ee</sub> = Power draw (expressed in Watts) of efficient (replacement) electrical equipment = 243 watts
- HOURS = annual operating hours= 5,202 (weighted average of all building stock)

**Commercial Lighting 6-Lamp T5 Fluorescent Lighting Fixture Replacing 400 watt Metal Halide**

Current typical existing lighting market (baseline)	High Bay HID – Metal Halide 400 W
Minimum threshold for credit	T5 High-output fluorescent lamps
Estimated savings credit for installing T5 High-Output <sup>1</sup>	1,015.4 kWh (per fixture)
Change in usage calculation <sup>2</sup>	$\Delta kWh = (WATTS_{base} - WATTS_{ee}) * HOURS * IF) / 1000^*$
Estimated demand savings credit for installing T5 High-Output <sup>1</sup>	0.165 kW (per fixture)
Measure life <sup>1</sup>	11 years
Incremental Cost <sup>1</sup>	\$ 256

[1] Taken from EMV PY 2 analysis

[2] Taken from Ohio TRM 2009

\*- If the appropriate field data required to complete this equation cannot be obtained, the deemed savings values in the table are to be used for each measure.

## Key Assumptions:

- Coincidence Factor (CF) = 0.95
- IF = Interactive Factor = 1.0 (assumed to be 1 for the first 3 year implementation program until further data can be gathered and consensus can be built).
- WATTS<sub>base</sub> = Power draw (expressed in Watts) of base (existing) interior electrical equipment = 560 watts
- WATTS<sub>ee</sub> = Power draw (expressed in Watts) of efficient (replacement) electrical equipment = 365 watts
- HOURS = annual operating hours= 5,202 (weighted average of all building stock)

## Appendix A – Technical Resource Manual

## Ameren Missouri

**Commercial Lighting Double 6-Lamp T5 Fluorescent Lighting Fixture Replacing 1000 watt HID**

Current typical existing lighting market (baseline)	High Bay HID – Metal Halide 1,000 W
Minimum threshold for credit	T5 High-output fluorescent lamps
Estimated savings credit for installing T5 High-Output <sup>1</sup>	1,456 kWh (per fixture)
Change in usage calculation <sup>2</sup>	$\Delta kWh = (WATTS_{base} - WATTS_{ee}) * HOURS * IF) / 1000^*$
Estimated demand savings credit for installing T5 High-Output <sup>1</sup>	0.333 kW (per fixture)
Measure life	12 years
Incremental Cost <sup>1</sup>	\$ 700

[1] Taken from Morgan Measure Libraries

[2] Taken from Ohio TRM 2009

\*- If the appropriate field data required to complete this equation cannot be obtained, the deemed savings values in the table are to be used for each measure.

## Key Assumptions:

- Coincidence Factor (CF) = 0.95
- IF = Interactive Factor = 1.0 (assumed to be 1 for the first 3 year implementation program until further data can be gathered and consensus can be built).
- $WATTS_{base}$  = Power draw (expressed in Watts) of base (existing) interior electrical equipment = 1,080 watts
- $WATTS_{ee}$  = Power draw (expressed in Watts) of efficient (replacement) electrical equipment = 730 watts
- HOURS = annual operating hours= 4,160 (lighting hour estimate taken from Morgan Measure Libraries)

**Commercial Lighting 4-Lamp T8 Fluorescent Lighting Fixture Replacing 250 watt HID**

Current typical existing lighting market (baseline)	High Bay HID – Metal Halide 250 W
Minimum threshold for credit	T8 Fluorescent
Estimated savings credit for installing T8 Fluorescent <sup>1</sup>	616 kWh (per fixture)
Change in usage calculation <sup>2</sup>	$\Delta kWh = (WATTS_{base} - WATTS_{ee}) * HOURS * IF) / 1000^*$
Estimated demand savings credit for installing T8 Fluorescent <sup>1</sup>	0.141 kW (per fixture)
Measure life <sup>1</sup>	12 years
Incremental Cost <sup>1</sup>	\$ 160

[1] Taken from Morgan Measure Libraries

[2] Taken from Ohio TRM 2009

\*- If the appropriate field data required to complete this equation cannot be obtained, the deemed savings values in the table are to be used for each measure.

**Appendix A – Technical Resource Manual****Ameren Missouri**

## Key Assumptions:

- Coincidence Factor (CF) = 0.95
- IF = Interactive Factor = 1.0 (assumed to be 1 for the first 3 year implementation program until further data can be gathered and consensus can be built).
- WATTS<sub>base</sub> = Power draw (expressed in Watts) of base (existing) interior electrical equipment = 290 watts
- WATTS<sub>ee</sub> = Power draw (expressed in Watts) of efficient (replacement) electrical equipment = 142 watts
- HOURS = annual operating hours= 4,160 (lighting hour estimate taken from Morgan Measure Libraries)

**Commercial Lighting 6-Lamp T8 Fluorescent Lighting Fixture Replacing 400 watt HID**

Current typical existing lighting market (baseline)	High Bay HID – Metal Halide 400 W
Minimum threshold for credit	T8 Fluorescent
Estimated savings credit for installing T8 Fluorescent <sup>1</sup>	961 kWh (per fixture)
Change in usage calculation <sup>2</sup>	$\Delta\text{kWh} = (\text{WATTS}_{\text{base}} - \text{WATTS}_{\text{ee}}) * \text{HOURS} * \text{IF} / 1000^*$
Estimated demand savings credit for installing T8 Fluorescent <sup>1</sup>	0.219 kW (per fixture)
Measure life <sup>1</sup>	12 years
Incremental Cost <sup>1</sup>	\$ 160

[1] Taken from Morgan Measure Libraries

[2] Taken from Ohio TRM 2009

\*- If the appropriate field data required to complete this equation cannot be obtained, the deemed savings values in the table are to be used for each measure.

## Key Assumptions:

- Coincidence Factor (CF) = 0.95
- IF = Interactive Factor = 1.0 (assumed to be 1 for the first 3 year implementation program until further data can be gathered and consensus can be built).
- WATTS<sub>base</sub> = Power draw (expressed in Watts) of base (existing) interior electrical equipment = 455watts
- WATTS<sub>ee</sub> = Power draw (expressed in Watts) of efficient (replacement) electrical equipment = 224 watts
- HOURS = annual operating hours= 4,160 (lighting hour estimate taken from Morgan Measure Libraries)



## Appendix A – Technical Resource Manual

## Ameren Missouri

**Commercial Lighting 8-Lamp T8 Fluorescent Lighting Fixture Replacing 400 watt HID**

Current typical existing lighting market (baseline)	High Bay HID – Metal Halide 400 W
Minimum threshold for credit	T8 Fluorescent
Estimated savings credit for installing T8 Fluorescent <sup>1</sup>	1,184 kWh (per fixture)
Change in usage calculation <sup>2</sup>	$\Delta kWh = ((WATTS_{base} - WATTS_{ee}) * HOURS * IF) / 1000^*$
Estimated demand savings credit for installing T8 Fluorescent <sup>1</sup>	0.22 kW (per fixture)
Measure life <sup>1</sup>	11 years
Incremental Cost <sup>1</sup>	\$ 414

[1] Based on Ameren Missouri PY 2 EMV analysis

[2] Taken from Ohio TRM 2009

\*- If the appropriate field data required to complete this equation cannot be obtained, the deemed savings values in the table are to be used for each measure.

## Key Assumptions:

- Coincidence Factor (CF) = 0.95
- IF = Interactive Factor = 1.0 (assumed to be 1 for the first 3 year implementation program until further data can be gathered and consensus can be built).
- $WATTS_{base}$  = Power draw (expressed in Watts) of base (existing) interior electrical equipment = 527 watts
- $WATTS_{ee}$  = Power draw (expressed in Watts) of efficient (replacement) electrical equipment = 299 watts
- HOURS = annual operating hours = 5,202 (weighted average of all building stock)

**Commercial Lighting Double 8-Lamp T8 Fluorescent Lighting Fixture Replacing 1,000 watt HID**

Current typical existing lighting market (baseline)	High Bay HID – Metal Halide 1,000 W
Minimum threshold for credit	T8 Fluorescent
Estimated savings credit for installing T8 Fluorescent <sup>1</sup>	2005 kWh (per fixture)
Change in usage calculation <sup>2</sup>	$\Delta kWh = ((WATTS_{base} - WATTS_{ee}) * HOURS * IF) / 1000^*$
Estimated demand savings credit for installing T8 Fluorescent <sup>1</sup>	0.458 kW (per fixture)
Measure life <sup>1</sup>	12 years
Incremental Cost <sup>1</sup>	\$ 400

[1] Taken from Morgan Measure Libraries

[2] Taken from Ohio TRM 2009

\*- If the appropriate field data required to complete this equation cannot be obtained, the deemed savings values in the table are to be used for each measure.

**Appendix A – Technical Resource Manual****Ameren Missouri**

## Key Assumptions:

- Coincidence Factor (CF) = 0.95
- IF = Interactive Factor = 1.0 (assumed to be 1 for the first 3 year implementation program until further data can be gathered and consensus can be built).
- $WATTS_{base}$  = Power draw (expressed in Watts) of base (existing) interior electrical equipment = 1,080 watts
- $WATTS_{ee}$  = Power draw (expressed in Watts) of efficient (replacement) electrical equipment = 598 watts
- HOURS = annual operating hours= 4,160 (lighting hour estimate taken from Morgan Measure Libraries)

**Commercial LED Exit Signs Replacing Incandescent Exit Sign**

Current typical existing lighting market (baseline)	Incandescent Exit Sign
Minimum threshold for credit	LED Exit Sign
Estimated savings credit for installing T5 High-Output <sup>1</sup>	237 kWh (per fixture)
Change in usage calculation <sup>2</sup>	$\Delta kWh = (WATTS_{base} - WATTS_{ee}) * HOURS * IF / 1000^*$
Estimated demand savings credit for installing T5 High-Output <sup>1</sup>	0.032kW (per fixture)
Measure life <sup>1</sup>	16 years
Incremental Cost <sup>1</sup>	\$ 63

[1] Based on Ameren Missouri PY 2 EMV report

[2] Taken from Ohio TRM 2009

\*- If the appropriate field data required to complete this equation cannot be obtained, the deemed savings values in the table are to be used for each measure.

## Key Assumptions:

- Coincidence Factor (CF) = 1.0
- IF = Interactive Factor = 1.0 (assumed to be 1 for the first 3 year implementation program until further data can be gathered and consensus can be built).
- $WATTS_{base}$  = Power draw (expressed in Watts) of base (existing) interior electrical equipment = 30 watts
- $WATTS_{ee}$  = Power draw (expressed in Watts) of efficient (replacement) electrical equipment = 3 watts
- HOURS = annual operating hours= 8,760

## Appendix A – Technical Resource Manual

## Ameren Missouri

**Commercial Pulse Start Metal Halide**

Current typical existing lighting market (baseline)	High Intensity Discharge Lamp
Minimum threshold for credit	Pulse Start Metal Halide
Estimated savings credit Pulse-start MH 150 – 200 W <sup>1</sup>	237 kWh
Estimated savings credit Pulse-start MH 320 W <sup>1</sup>	354 kWh
Estimated savings credit Pulse-start MH 750 W <sup>1</sup>	1,090 kWh
Change in usage calculation <sup>2</sup>	$\Delta kWh = (WATTS_{base} - WATTS_{ee}) * HOURS * IF) / 1000^*$
Estimated demand savings credit Pulse-start MH 150 – 200 W <sup>1</sup>	0.054 kW
Estimated demand savings credit Pulse-start MH 320 W <sup>1</sup>	0.081 kW
Estimated demand savings credit Pulse-start MH 750 W <sup>1</sup>	0.249 kW
Measure life <sup>1</sup>	16 years
Incremental Cost Pulse-start MH 150 – 200 W <sup>1</sup>	\$ 135
Incremental Cost Pulse-start MH 320 W <sup>1</sup>	\$ 150
Incremental Cost Pulse-start MH 750 W <sup>1</sup>	\$ 200

[1] Taken from Morgan Measure Libraries

[2] Taken from Ohio TRM 2009

\*- If the appropriate field data required to complete this equation cannot be obtained, the deemed savings values in the table are to be used for each measure.

## Key Assumptions:

- Coincidence Factor (CF) = 0.95
- IF = Interactive Factor = 1.0 (assumed to be 1 for the first 3 year implementation program until further data can be gathered and consensus can be built).
- $WATTS_{base}$  = Power draw (expressed in Watts) of base (existing) interior electrical equipment = See table below.
- $WATTS_{ee}$  = Power draw (expressed in Watts) of efficient (replacement) electrical equipment = See table below.
- HOURS = annual operating hours= 4,160 (lighting hour estimate taken from Morgan Measure Libraries)

Efficient Measure	Baseline Measure	Wattseffic	Wattsbase
Average 150, 175, 200	Avg 175 and 250	210	267
320 Watt Metal Halide- Pulse Start	400 W HID	370	455
750 Watt Metal Halide - Pulse Start	1000 W HID	818	1080

## Appendix A – Technical Resource Manual

## Ameren Missouri

**Commercial Ceramic Metal Halide (20 – 100 watt)**

Current typical existing lighting market (baseline)	Incandescent Display Lighting
Minimum threshold for credit	Ceramic Metal Halide
Estimated savings credit Pulse-start MH 150 – 200 W <sup>1</sup>	445 kWh
Change in usage calculation <sup>2</sup>	$\Delta kWh = (WATTS_{base} - WATTS_{ee}) * HOURS * IF) / 1000^*$
Estimated demand savings credit Pulse-start MH 150 – 200 W <sup>1</sup>	0.115 kW
Measure life <sup>1</sup>	16 years
Incremental Cost Pulse-start MH 150 – 200 W <sup>1</sup>	\$ 225

[1] Taken from Morgan Measure Libraries

[2] Taken from Ohio TRM 2009

\*- If the appropriate field data required to complete this equation cannot be obtained, the deemed savings values in the table are to be used for each measure.

## Key Assumptions:

- Coincidence Factor (CF) = 0.95
- IF = Interactive Factor = 1.0 (assumed to be 1 for the first 3 year implementation program until further data can be gathered and consensus can be built).
- $WATTS_{base}$  = Power draw (expressed in Watts) of base (existing) interior electrical equipment = 185 watts
- $WATTS_{ee}$  = Power draw (expressed in Watts) of efficient (replacement) electrical equipment = 64 watts
- HOURS = annual operating hours= 3,680 (lighting hour estimate taken from Morgan Measure Libraries)

**Commercial LED/Induction Garage Light Replacing HID Exterior Light**

Current typical existing lighting market (baseline)	High Intensity Discharge Lamp
Minimum threshold for credit	LED/Induction
Estimated savings credit Pulse-start MH 175 – 250 W <sup>1</sup>	936 kWh
Estimated savings credit Pulse-start MH 400 W <sup>1</sup>	1,614 kWh
Change in usage calculation <sup>2</sup>	$\Delta kWh = (WATTS_{base} - WATTS_{ee}) * HOURS * IF) / 1000^*$
Estimated demand savings credit Pulse-start MH 175 – 250 W <sup>1</sup>	0.102 kW
Estimated demand savings credit Pulse-start MH 400 W <sup>1</sup>	0.175 kW
Measure life <sup>1</sup>	12 years
Incremental Cost Ceramic MH 175 – 200 W <sup>1</sup>	\$ 500
Incremental Cost Ceramic MH 400 W <sup>1</sup>	\$ 800

[1] Taken from Morgan Measure Libraries

[2] Taken from Ohio TRM 2009

**Appendix A – Technical Resource Manual****Ameren Missouri**

\*- If the appropriate field data required to complete this equation cannot be obtained, the deemed savings values in the table are to be used for each measure.

## Key Assumptions:

- Coincidence Factor (CF) = 0.95
- IF = Interactive Factor = 1.0 (assumed to be 1 for the first 3 year implementation program until further data can be gathered and consensus can be built).
- WATTS<sub>base</sub> MH 400 watt = Power draw (expressed in Watts) of base (existing) interior electrical equipment = 461 watts
- WATTS<sub>ee</sub> MH 400 watt = Power draw (expressed in Watts) of efficient (replacement) electrical equipment = 279 watts
- WATTS<sub>base</sub> MH 175 – 250 watt = Power draw (expressed in Watts) of base (existing) interior electrical equipment = 267 watts
- WATTS<sub>ee</sub> MH 175 – 250 watt = Power draw (expressed in Watts) of efficient (replacement) electrical equipment = 160 watts
- HOURS = annual operating hours= 8,760

**Commercial Compact Fluorescent Lights/LED Replacing Incandescent Bulb**

Current typical existing lighting market (baseline)	Incandescent (or EISA compliant equivalent)
Minimum threshold for credit	Compact Fluorescent Lights
Estimated savings CFL	See table below
Change in usage calculation <sup>2</sup>	$\Delta kWh = (WATTS_{base} - WATTS_{ee}) * HOURS * IF) / 1000^*$
Estimated demand savings credit CFL	See table below
Measure life	See table below
Incremental Cost CFL	See table below

[1] Taken from Morgan Measure Libraries

[2] Taken from Ohio TRM 2009

\*- If the appropriate field data required to complete this equation cannot be obtained, the deemed savings values in the table are to be used for each measure.

## Key Assumptions:

- Coincidence Factor (CF) = 0.95
- IF = Interactive Factor = 1.0 (assumed to be 1 for the first 3 year implementation program until further data can be gathered and consensus can be built).
- WATTS<sub>base</sub> = Power draw (expressed in Watts) of base (existing) interior electrical equipment = See table below.
- WATTS<sub>ee</sub> = Power draw (expressed in Watts) of efficient (replacement) electrical equipment = See table below.
- HOURS = annual operating hours= 3,680 (lighting hour estimate taken from Morgan Measure Libraries)

## Appendix A – Technical Resource Manual

## Ameren Missouri

Efficient Measure	Baseline Measure	Watts effic	Watts base	kWh Saving s	Coincid ent kW Savings	Incr. Cost	Mea sure Life
Compact fluorescent lamp less than 30W <sup>1</sup>	Incandescent lamp	19	74	202	0.05	\$3	2
Compact fluorescent lamp ≤ 30W X ≤ 115W <sup>1</sup>	Incandescent lamp	65	200	497	0.12	\$15	2
Compact fluorescent lamps with reflectors <sup>1</sup>	Incandescent lamps with reflectors	19	74	202	0.05	\$6	2
GU-24 pin-based CFL <sup>2</sup>	Incandescent ≤ 100W	21	100	411	0.04	\$11	12
Interior CF 1L 26W Quad <sup>2</sup>	Incandescent	26	169	745	0.14	\$92	11
Interior CF 1L 32W Triple <sup>2</sup>	Incandescent	32	65	172	0.03	\$135	11
New pin-based CFL Fixture (>45W) <sup>2</sup>	Incandescent >100W	45	224	1,402	0.14	\$327	11
LED lamp <sup>1</sup>	Incandescent lamp	12	60	177	0.04	\$ 70	15

[1] Taken from Morgan Measure Libraries: assumes 3,680 hours

[2] Based on Ameren Missouri PY 2 EMV report from ADM: assumes 5,202 hours

### Commercial LED Case Lighting

Current typical existing lighting market (baseline)	T8 Fluorescent
Minimum threshold for credit	LED replacement
Estimated savings <sup>1</sup>	429 kWh per door
Change in usage calculation <sup>2</sup>	$\Delta kWh = (WATTS_{base} - WATTS_{ee}) * HOURS * IF / 1000^*$
Estimated demand savings credit <sup>1</sup>	0.041 kW per door
Measure life <sup>1</sup>	15 years
Incremental Cost <sup>1</sup>	\$ 300

[1] Taken from Morgan Measure Libraries

[2] Taken from Ohio TRM 2009

\*- If the appropriate field data required to complete this equation cannot be obtained, the deemed savings values in the table are to be used for each measure.

#### Key Assumptions:

- 25% of heat is lost through the case
- IF = Interactive Factor = 1.0
- Coincidence Factor (CF) = 0.95
- IF = Interactive Factor = 1.0 (assumed to be 1 for the first 3 year implementation program until further data can be gathered and consensus can be built).
- $WATTS_{base}$  = Power draw (expressed in Watts) of base (existing) interior electrical equipment = T8 Lighting (74 watts) + refrigeration load (25 watts) = 99 watts
- $WATTS_{ee}$  = Power draw (expressed in Watts) of efficient (replacement) electrical equipment = LED (37 watts) + refrigeration load (13 watts) = 50 watts

## Appendix A – Technical Resource Manual

## Ameren Missouri

- HOURS = annual operating hours= 8,760

### Lighting Controls

Current typical existing lighting market (baseline)	No Controls
Minimum threshold for credit	Automated or motion controls
Estimated kWh savings <sup>1</sup>	See table below
Change in usage calculation <sup>2</sup>	
Estimated demand savings <sup>1</sup>	See table below
Measure life <sup>1</sup>	10 years
Incremental Cost <sup>1</sup>	See table below

[1] Taken from Morgan Measure Libraries

[2] Taken from Ohio TRM 2009

\*- If the appropriate field data required to complete this equation cannot be obtained, the deemed savings values in the table are to be used for each measure.

#### Key Assumptions:

- 3,680 hours of operation (lighting hour estimate taken from Morgan Measure Libraries)
- SF = square feet of controlled lighting space
- Watt/SF = watt per square feet of controlled lighting space
- Coincidence Factor (CF) = 0.90 (Daylight Sensor Controls have CF = 0.95)
- DF = Diversity Factor (assumed at 0.9)

Measure	Square Feet	% Reduction	Watt/SF	kWh	Coincident kW	Incremental Cost	Measure Life
Occupancy Sensors under 500 W <sup>1</sup>	300	30%	1.20	397	0.099	\$144	10
Occupancy Sensors over 500 W <sup>1</sup>	750	30%	1.20	994	0.243	\$311	10
Central Lighting Control <sup>1</sup>	10,000	25%	1.25	11500	2.808	\$3,700	12
Switching Controls for Multilevel Lighting <sup>1</sup>	10,000	18%	1.25	8000	2.196	\$4,000	12
Daylight Sensor controls <sup>1</sup>	10,000	30%	1.30	14800	3.819	\$4,000	12
Passive Infrared or Ultrasonic <sup>2</sup>				616.3	0.023	\$92	11
Dual Technology Sensors <sup>2</sup>				770.4	0.034	\$128	8
Interior Wall Sensors (3 2-lamp T8 fixtures) <sup>2</sup>				620.9	0.060	\$91	11

[1] Taken from Morgan Measure Libraries

[2] Based on Ameren Missouri PY 2 EMV report

## Appendix A – Technical Resource Manual

## Ameren Missouri

### Retro-commissioning Lighting

Current typical existing market (baseline)	Conventional Lighting Set-up at existing facility
Minimum threshold for credit	5% Improvement in building's lighting load
Estimated savings for 5 degree reset <sup>1</sup>	5,311.4 kWh
Estimated savings for 10 degree reset <sup>1</sup>	0.939 kW
Measure life <sup>1</sup>	5 years
Incremental Cost <sup>1</sup>	\$ 761 per project

[1] Taken from Morgan Measure Libraries (GEP Potential Study Measure list)

#### Key Assumptions:

- Assumes 6% savings of building's lighting energy consumption

### Commercial Cooking Equipment

#### Energy Star Steam Cookers

Current typical existing cooking market (baseline)	Electric Steam Cooker (26% efficient)
Minimum threshold for credit	Energy Star Steam Cooker (50% efficient)
Estimated savings credit 3 pan <sup>1</sup>	11,188 kWh
Estimated savings credit 4 pan <sup>1</sup>	12,159 kWh
Estimated savings credit 5 pan <sup>1</sup>	13,139 kWh
Estimated savings credit 6 pan <sup>1</sup>	15,170 kWh
Change in usage calculation <sup>1</sup>	$\Delta kWh = LB_{Food} * \frac{E_{Food}}{\Delta Efficiency} + (1 - PTMM) * \Delta IdleRate * (OpHrs - \frac{LB_{Food}}{\Delta PC} - \frac{T_{preHT}}{60}) + E_{preHT} * Days$
Estimated demand	2.55 kW/unit



**Appendix A – Technical Resource Manual****Ameren Missouri**

savings credit 3 pan <sup>1</sup>	
Estimated demand savings credit 4 pan <sup>1</sup>	2.85 kW/unit
Estimated demand savings credit 5 pan <sup>1</sup>	3.16 kW/unit
Estimated demand savings credit 6 pan <sup>1</sup>	3.46 kW/unit
Measure life <sup>1</sup>	12 years
Incremental Cost <sup>1</sup>	\$4,150

[1] Taken from Morgan Measure Libraries

[2] Taken from Ohio TRM 2009

\*- If the appropriate field data required to complete this equation cannot be obtained, the deemed savings values in the table are to be used for each measure.

**Key Assumptions:**

- One pre-heat daily, the preheat time is assumed to be 15 minutes, and the preheat energy 1.5 kWh/day.
- The amount of food cooked per day in each size of cooker is assumed to be:
  - 3 pan - 100 lbs
  - 4 pan - 128 lbs
  - 5 pan - 160 lbs
  - 6 pan - 192 lbs
- The ASTM Energy to Food value used is 0.0308 kWh/lb.
- PTMM = average amount of time per day steamer is operated in manual (constant steam) mode. Expressed as percentage per day.
- Days = days per year = 365
- CF = Coincidence Factor = 1.0

E<sub>Day</sub> = Daily Energy Consumption (kWh/day) or (BTU/day)

L<sub>B</sub>F<sub>ood</sub> = Pounds of Food Cooked per Day (lb/day)

E<sub>food</sub> = ASTM Energy to Food (kWh/lb) = kWh/pound of energy absorbed by food product during cooking or (BTU/lb)

Efficiency = Heavy Load Cooking Energy Efficiency %

I<sub>IdleRate</sub> = Idle Energy Rate (kW) or (BTU/hr)

O<sub>phrs</sub> = Operating Hours/Day (hr/day) = 12

P<sub>C</sub> = Production Capacity (lbs/hr)

**Appendix A – Technical Resource Manual**

**Ameren Missouri**

---

TPreHt = Preheat Time (min/day)  
EPreHt = Preheat Energy (kWh/day) or (BTU/day)  
ResidualRate = Residual Energy Rate (kW)

## Appendix A – Technical Resource Manual

## Ameren Missouri

**Energy Hot Food Holding Cabinets (full size)**

Current typical existing cooking market (baseline)	Electric Hot Food Holding Cabinets (70 W/ft <sup>3</sup> )
Minimum threshold for credit	Energy Star Hot Food Holding Cabinet (< 40 W/ft <sup>3</sup> internal volume)
Estimated savings credit full size <sup>1</sup>	5,278 kWh
Estimated savings credit three- quarter size <sup>1</sup>	2,832 kWh
Estimated savings credit half size <sup>1</sup>	1,788 kWh
Change in usage calculation <sup>1</sup>	$\Delta\text{kWh} = \frac{\text{InternalVolume} * (\Delta\text{Watts} / \text{Volume}) * (\text{Hours} / \text{Year})}{1000} *$
Estimated demand savings credit full size <sup>1</sup>	0.96 kW/unit
Estimated demand savings credit three- quarter size <sup>1</sup>	0.52 kW/unit
Estimated demand savings credit half size <sup>1</sup>	0.33 kW/unit
Measure life <sup>1</sup>	12 years
Incremental Cost <sup>1</sup>	\$1,783

[1] Taken from Morgan Measure Libraries

\*- If the appropriate field data required to complete this equation cannot be obtained, the deemed savings values in the table are to be used for each measure.

## Key Assumptions:

- The demand is assumed to be the average demand (per Food Service Technology Center).
- Hot Food Holding Cabinets operate 15 hours per day (same assumption as used by the Food Service Technology Center and the ENERGY STAR savings calculator).
- The volume of each size range for calculation purposes (as also used in the ENERGY STAR calculator and the Food Service Technology Center workpapers) are:
  - Full Size - >15 ft<sup>3</sup> (average volume used is 20 ft<sup>3</sup>)
  - Three-quarter Size – 10-15 ft<sup>3</sup> (average volume used is 12 ft<sup>3</sup>)
  - Half Size - <10 ft<sup>3</sup> (average volume used is 8 ft<sup>3</sup>)
- Coincidence Factor = CF = 1.0

## Commercial Refrigeration

### Energy Star Commercial Refrigerators and Freezers

Current typical existing market (baseline)	Type	kWh Base
	Solid Door Refrigerators <sup>1</sup>	$0.1 * \text{Volume} + 2.04$
	Glass Door Refrigerators <sup>1</sup>	$0.12 * \text{Volume} + 3.34$
	Solid Door Freezers <sup>1</sup>	$0.4 * \text{Volume} + 1.38$
	Glass Door Freezers <sup>1</sup>	$0.75 * \text{Volume} + 4.11$
Minimum threshold for credit	See table below	
Estimated savings <sup>1</sup>	See Table Below	
Measure life <sup>1</sup>	12 years	
Incremental Cost <sup>1</sup>	See table below	

[1] Taken from Morgan Measure Libraries

#### Key Assumptions:

- 8760 operating hours per year
- CF (coincident peak factor)

Product Volume (in cubic feet)	Refrigerator	Freezer
<i>Solid Door Cabinets</i>		
$0 < V < 15$	$\leq 0.089V + 1.411$	$\leq 0.250V + 1.250$
$15 \leq V < 30$	$\leq 0.037V + 2.200$	$\leq 0.400V - 1.000$
$30 \leq V < 50$	$\leq 0.056V + 1.635$	$\leq 0.163V + 6.125$
$50 \leq V$	$\leq 0.060V + 1.416$	$\leq 0.158V + 6.333$
<i>Glass Door Cabinets</i>		
$0 < V < 15$	$\leq 0.118V + 1.382$	$\leq 0.607V + 0.893$
$15 \leq V < 30$	$\leq 0.140V + 1.050$	$\leq 0.733V - 1.000$
$30 \leq V < 50$	$\leq 0.088V + 2.625$	$\leq 0.250V + 13.500$
$50 \leq V$	$\leq 0.110V + 1.500$	$\leq 0.450V + 3.500$

[1] Morgan Measure Libraries

## Appendix A – Technical Resource Manual

## Ameren Missouri

*Efficient Refrigerators and Freezers Savings and Costs*

Measure	kWh Savings	kW Savings	Incremental Cost
ENERGY STAR Commercial Solid Door Freezers less than 15ft <sup>3</sup>	595.0	0.068	\$ 150
ENERGY STAR Commercial Solid Door Freezers 15 to 30 ft <sup>3</sup>	869.0	0.099	\$ 400
ENERGY STAR Commercial Solid Door Freezers 30 to 50ft <sup>3</sup>	1,728.0	0.197	\$ 550
ENERGY STAR Commercial Solid Door Freezers more than 50ft <sup>3</sup>	3,757.0	0.429	\$ 700
ENERGY STAR Commercial Glass Door Refrigerators less than 15ft <sup>3</sup>	722.0	0.082	\$ 250
ENERGY STAR Commercial Glass Door Refrigerators 15 to 30 ft <sup>3</sup>	1,434.0	0.164	\$ 500
ENERGY STAR Commercial Glass Door Freezers less than 15ft <sup>3</sup>	1,693.0	0.193	\$ 220
ENERGY STAR Commercial Glass Door Freezers 15 to 30 ft <sup>3</sup>	2,004.0	0.229	\$ 950
ENERGY STAR Commercial Glass Door Freezers 30 to 50ft <sup>3</sup>	3,869.0	0.442	\$ 1,307
ENERGY STAR Commercial Glass Door Freezers more than 50ft <sup>3</sup>	7,118.0	0.813	\$ 2,300

**Appendix A – Technical Resource Manual****Ameren Missouri****Energy Star Ice Machines**

Current typical existing market (baseline)	N/A
Minimum threshold for credit	Energy Star Certified Ice Machines
Estimated savings < 500 lbs/24 hours <sup>1</sup>	1,652 kWh/unit
Estimated savings 500 – 1000 lbs/24 hours <sup>1</sup>	2,695 kWh/unit
Estimated savings >1000 lbs/24 hours <sup>1</sup>	6,048 kWh/unit
Change in usage calculation <sup>1</sup>	
Estimated demand savings < 500 lbs/24 hours <sup>1</sup>	0.1886 kW/unit
Estimated demand savings 500 – 1000 lbs/24 hours <sup>1</sup>	0.3077 kW/unit
Estimated demand savings >1000 lbs/24 hours <sup>1</sup>	0.6904 kW/unit
Measure life <sup>1</sup>	12 years
Incremental Cost < 500 lbs/24 hours <sup>1</sup>	\$600
Incremental Cost 500 – 1000 lbs/24 hours <sup>1</sup>	\$1,500
Incremental Cost >1000 lbs/24 hours <sup>1</sup>	\$2,000

[1] Taken from Morgan Measure Libraries

\*- If the appropriate field data required to complete this equation cannot be obtained, the deemed savings values in the table are to be used for each measure.

## Key Assumptions:

- Load Factor = LF =75% = pounds of ice used per day or Ice Harvest rate
- Ice Harvest Rate = lbs/24 hours
- 8760 operating hours per year
- Coincidence Factor = CF = 1.0

## Appendix A – Technical Resource Manual

## Ameren Missouri

### Anti-Sweat Heater Controls

Current typical existing market (baseline)	Door with no control
Minimum threshold for credit	Automated Control
Estimated savings <sup>1</sup>	1,367 kWh per unit
Change in usage calculation <sup>2</sup>	$\Delta kWh = kW_{base} * NUM_{doors} * ESF * BF *$
Estimated demand savings <sup>1</sup>	0.079 kW per unit
Measure life <sup>1</sup>	12 years
Incremental Cost <sup>1</sup>	\$ 151

[1] Based on Ameren Missouri PY 2 EMV report

[2] Taken from Ohio TRM 2009

\*- If the appropriate field data required to complete this equation cannot be obtained, the deemed savings values in the table are to be used for each measure.

#### Key Assumptions:

- NUMdoors = number of doors
- ESF = Energy Savings Factor; percentage of annual hours door heater is powered off due to control (assume 60%)
- BF = Bonus Factor = increased savings due to reduction in cooling load inside cases. Assume 1.15.
- kWbase = connected load kW for typical reach-in refrigerator or freezer door and frame with a heater.

### Strip Curtains for Walk-in Coolers

Current typical existing market (baseline)	No curtains
Minimum threshold for credit	Strip curtains installed
Estimated savings <sup>1</sup>	5058 kWh per unit
Estimated demand savings credit <sup>1</sup>	0.628 kW per unit
Measure life <sup>1</sup>	4 years
Incremental Cost <sup>1</sup>	\$ 132

[1] Based on Ameren Missouri PY 2 EMV report

### Beverage Vending Machine Controls

Current typical existing market (baseline)	Beverage Vending Machine with no controls
Minimum threshold for credit	Beverage vending machine <del>with</del> -automated/motion controls
Estimated savings <sup>1</sup>	1,646 kWh per unit
Change in usage calculation <sup>2</sup>	$\Delta kWh = 8760 * WATTS_{base} / 1000 * ESF *$
Estimated demand savings credit <sup>1</sup>	0.055 kW per unit
Measure life <sup>1</sup>	5 years
Incremental Cost <sup>1</sup>	\$ 141

[1] Based on Ameren Missouri PY 2 EMV report

[2] Taken from Ohio TRM 2009

\*- If the appropriate field data required to complete this equation cannot be obtained, the deemed savings values in the table are to be used for each measure.

Key Assumptions:

- ESF = Energy Savings Factor = 35% (per Morgan Measure Library)
- WATTSbase = 536.85 watts per unit

Alternatively, if the variables listed in the above equation are not available, the following equation and parameters can be used to estimate savings:



## Appendix A – Technical Resource Manual

## Ameren Missouri

**Efficient Refrigeration Condenser**

Current typical existing market (baseline) <sup>1</sup>	Medium Temperature System = 15°F design approach Low Temperature System = 10°F design approach
Minimum threshold for credit <sup>1</sup>	Condenser design temperature approach must be at or below the following parameters: Air-cooled condensers (exiting refrigerant vs. ambient dry bulb temperature): low temperature systems (8°F) and medium temperature systems (13°F). Evaporative-cooled condensers (exiting refrigerant vs. ambient wet bulb temperature): 18°F.
Change in use Calculation <sup>1</sup>	
Estimated savings <sup>1</sup>	120 kWh per ton
Estimated demand savings credit <sup>1</sup>	0.118 kW per ton
Measure life <sup>1</sup>	15 years
Incremental Cost <sup>1</sup>	\$ 35 per ton

[1] Taken from Morgan Measure Libraries

\*- If the appropriate field data required to complete this equation cannot be obtained, the deemed savings values in the table are to be used for each measure.

Key Assumptions:

- FLH = Full Load Hours = 4,380 hours
- System Capacity = Full Load = 2.3 kW/ton at 105°F saturated condensing temp.
- Average Annual Load
- Baseline (10°F condenser approach) operating based on 82F ambient had an average. load of 81.6%; based on 70F ambient had an average. load of 78.9%
- Efficient (7°F condenser approach) operating based on 82F ambient had an average. load of 83.2%; based on 70F ambient had an average. load of 80%
- FLE = Full Load Efficiency
  - Baseline: based on 82F 1.92 kW/ton; based on 70F 1.85 kW/ton
  - Efficient based on 82F 1.86 kW/ton; based on 70F 1.78 kW/ton

**Night Covers**

<u>Current typical existing market (baseline)<sup>1</sup></u>	<u>No Covers</u>
<u>Minimum threshold for credit<sup>1</sup></u>	<u>Night covers installed</u>
<u>Estimated savings credit<sup>1</sup></u>	<u>43.8 kWh per linear foot</u>
<u>Estimated demand savings credit<sup>1</sup></u>	<u>0.00 kW per linear foot</u>
<u>Measure life<sup>1</sup></u>	<u>10 years</u>
<u>Incremental Cost<sup>1</sup></u>	<u>\$ 15 per linear foot</u>

[1] Numbers derived from 2011 Massachusetts Technical Reference Manual.

$$\Delta kWh = (Width)(Save)(Hours)$$

$$\Delta kW = (Width)(Save)$$

- Width = Width of the opening that the night covers protect (ft)

## Appendix A – Technical Resource Manual

## Ameren Missouri

- Save = Savings factor based on the temperature of the cooler case (kW/ft)
- Hours = Annual hours that the night covers are in use

### Cooler Case Temperature Savings Factor

- Low Temperature (-35 F to -5 F) 0.03 kW/ft
- Medium Temperature (0 F to 30 F) 0.02 kW/ft
- High Temperature (35 F to 55 F) 0.01 kW/ft

### Key Assumptions:

1. Applicant must install a night cover on an open refrigerated case at close of business each day. The savings estimate for this measure assumes that a night cover is placed on an open case that was previously left uncovered.
2. Hours of operation = for a minimum of 6 hours per day, assumed 2,190 hours per year

### ECM for Refrigeration

<u>Current typical existing market (baseline)<sup>1</sup></u>	<u>Shaded Pole or PSC on existing case</u>
<u>Minimum threshold for credit<sup>1</sup></u>	<u>ECM installed</u>
<u>Estimated savings credit<sup>1</sup></u>	<u>544 kWh</u>
<u>Estimated demand savings credit<sup>1</sup></u>	<u>0.062 kW</u>
<u>Measure life<sup>1</sup></u>	<u>15 years</u>
<u>Incremental Cost<sup>1</sup></u>	<u>\$ 114</u>

[1] Numbers derived from DEER 2005.

### Key Assumptions:

1. ECM savings are based on an average of typical sizes of ECM's over PSC motors, as well as ECM's over shaded-pole motors for all types of refrigeration cases, (i.e. large walk-ins, small frozen, coffin style, etc.)
2. User surveys from retailers were conducted to determine the single weighted-average of savings values among types of refrigeration cases.
3. Minimum qualifying ECM size is 1/20 hp.

The following algorithms specify how Gross energy savings and demand reduction for motor upgrades are calculated<sup>6</sup>:

$$\Delta \text{kWhFAN} = \text{RHP} \times 0.746 \times \text{LF} \times (1/\text{ME-base} - 1/\text{ME-eff.}) \times \text{EFLH}$$

$$\Delta \text{kWhHEAT} = \Delta \text{kWhFAN} \times 0.28 \times \text{EFF}_{\text{RS}}$$

$$\Delta \text{kW} = \text{RHP} \times 0.746 \times \text{LF} \times (1/\text{MF-base} - 1/\text{MF-eff.}) \times \text{CF}$$

Where:

$\Delta \text{kWhFAN}$  = Energy savings due to increased motor efficiency

$\Delta \text{kWhHEAT}$  = Energy savings due to reduced heat from evaporator fans

RHP = Horsepower rating of motor (hp) as shown on nameplate

0.746 = Conversion Factor (0.746 kW/hp)

<sup>6</sup>Lockheed Martin, Cycle 1 Ameren Missouri TRM calculations 2009 – 2011. Massachusetts TRM 2011.

**Appendix A – Technical Resource Manual****Ameren Missouri**

LF = Load Factor of motor (ratio of maximum operating hp load to nameplate hp)  
ME-base = Efficiency of base (existing) motor  
ME-eff. = Efficiency of replacement (efficient) motor  
UF = Utilization Factor of motor (ratio of average annual hp load to maximum operating hp load)  
AOH = Annual operating hours of motor  
EFLH = Equivalent Full-Load Hours = AOH x UF  
CF = Coincidence Factor (percentage of a motor's maximum power draw during Ameren's peak system demand period)  
EFF<sub>RS</sub> = Efficiency of typical refrigeration system – 1.6 kW/ton. (60%)

**Auto door closers**

<u>Current typical existing market (baseline)<sup>1</sup></u>	<u>Low or Medium Temperature walk in or reach in (-10 to 41F)</u>
<u>Minimum threshold for credit<sup>1</sup></u>	<u>Auto Door closer installed</u>
<u>Estimated savings credit<sup>1</sup></u>	<u>681 kWh</u>
<u>Estimated demand savings credit<sup>1</sup></u>	<u>0.223 kW</u>
<u>Measure life<sup>1</sup></u>	<u>8 years</u>
<u>Incremental Cost<sup>2</sup></u>	<u>\$ 157</u>

[1] Numbers derived from DEER 2005.

[2] Costs taken from Illinois TRM 2012.

**Key Assumptions:**

- Measures consist of installing an automatic door closer on an existing walk-in cooler or freezer door.
- Using the door open time estimate, energy savings captured by the automatic door closer is calculated to be approximately 12% of cooling load for each case type.
- Auto door closers should be applied to the main insulated door of a walk-in or reach-in cooler or freezer.
- For both walk-in and reach-in cases, the minimum door perimeter is 16 feet.
- One closer per case door.

**Commercial Hot Water Measures****Commercial Heat Pump Hot Water Heaters**

<u>Current typical existing market (baseline)</u>	<u>98%</u>
<u>Minimum threshold for credit</u>	<u>≥ 3.0 COP</u>
<u>Estimated savings 10,000 – 50,000 BTU/h<sup>1</sup></u>	<u>21,156 kWh/unit</u>
<u>Estimated savings 50,000 – 100,000 BTU/h<sup>1</sup></u>	<u>52,890 kWh/unit</u>
<u>Estimated savings 100,000 – 300,000 BTU/h<sup>1</sup></u>	<u>141,041 kWh/unit</u>

## Appendix A – Technical Resource Manual

## Ameren Missouri

Estimated savings 300,000 – 500,000 BTU/h <sup>1</sup>	282,081 kWh/unit
Estimated savings > 500,000 BTU/h <sup>1</sup>	423,122 kWh/unit
Change in usage calculation <sup>2</sup>	
Estimated savings 10,000 – 50,000 BTU/h <sup>1</sup>	4.2 kW/unit
Estimated demand savings 50,000 – 100,000 BTU/h <sup>1</sup>	10.5 kW/unit
Estimated demand savings 100,000 – 300,000 BTU/h <sup>1</sup>	28 kW/unit
Estimated demand savings 300,000 – 500,000 BTU/h <sup>1</sup>	56 kW/unit
Estimated demand savings > 500,000 BTU/h <sup>1</sup>	84 kW/unit
Measure life <sup>1</sup>	15 years
Incremental Cost 10,000 – 50,000 BTU/h <sup>1</sup>	\$6,000
Incremental Cost 50,000 – 100,000 BTU/h <sup>1</sup>	\$14,000
Incremental Cost 100,000 – 300,000 BTU/h <sup>1</sup>	\$25,000
Incremental Cost 300,000 – 500,000 BTU/h <sup>1</sup>	\$42,000
Incremental Cost > 500,000 BTU/h <sup>1</sup>	\$63,000

[1] Taken from Morgan Measure Libraries

[2] Taken from Ohio TRM 2009, addition of DF from Morgan Measure Libraries

\*- If the appropriate field data required to complete this equation cannot be obtained, the deemed savings values in the table are to be used for each measure.

## Key Assumptions:

- E<sub>t</sub> Base: Thermal efficiency of a standard commercial electric water heater: 98%
- COP of an ASHP water heater: 3.5
- Cost estimates include installation.
- 77°F temperature difference from makeup water to hot water supply (Standard US DOE Test Procedure)
- Diversity Factor (DF): 0.65 = impact on demand of diversity between multiple water heating units in building.
- Heaters are generally located in unconditioned spaces
- 360 days per year
- E<sub>t</sub> Base: Thermal efficiency of existing unit

**Pre-Rinse Spray Valves**

Current typical existing market (baseline)	≥1.6 gpm
Minimum threshold for credit	≤ 0.64 gpm
Estimated savings <sup>1</sup>	5,626 kWh

## Appendix A – Technical Resource Manual

## Ameren Missouri

Change in usage calculation <sup>1</sup>	*
Estimated demand savings credit full size <sup>1</sup>	0.116 kW/unit
Measure life <sup>1</sup>	5 years
Incremental Cost <sup>1</sup>	\$67

[1] Taken from Morgan Measure Libraries

\*- If the appropriate field data required to complete this equation cannot be obtained, the deemed savings values in the table are to be used for each measure.

### Key Assumptions:

- Cold Water Supply Temperature: 60°F, Hot Water Supply Temperature (from sprayer) of 128°F
- Average use of 5.1 hour per week (approximately 265.20 hours per year)
- Assumes 100% EF water heater
- Baseline GPM assumed to be 2.78 GPM

### Low Flow Faucet Aerators

Current typical existing market (baseline)	≥2.5 gpm
Minimum threshold for credit	1.5 gpm
Estimated savings <sup>1</sup>	174 kWh
Change in usage calculation <sup>2</sup>	$\Delta kWh = [Q \times 8.33 \times T_d] / 3,413 / EF$
Estimated demand savings credit full size <sup>1</sup>	0.017 kW/unit
Measure life <sup>1</sup>	9 years
Incremental Cost <sup>1</sup>	\$12

[1] Taken from Morgan Measure Libraries

[2] Taken from AmerenUE Business TRM 2008

\*- If the appropriate field data required to complete this equation cannot be obtained, the deemed savings values in the table are to be used for each measure.

### Key Assumptions:

- $Q$  = flow rate savings, gallons per year =  $1,048 \text{ gallons/yr} = \Delta \text{GPM} \times 1 \text{ min per use} \times 365 \text{ days} \times 5.74 \text{ persons} \div 2 \text{ fixtures}^1$
- 8.33 = conversion factor (Btu/gal-°F)
- $T_d$  = Temperature difference between hot water setting and makeup water temperature = 68°F
- EF = Efficiency of electric water heater = 100%
- 3,413 = Btu per kWh

[1] Taken from Ameren Illinois Potential Study 2009 measure list.

### Commercial Motors-Pumps and Drives

Commercial ~~motors-pumps~~ and drives can be deemed, but many of these measures will include sufficient variability in usage that the project would likely follow a custom analysis. It is important to identify the appropriate baseline efficiency when conducting ~~motors-pumps~~ and drives savings calculations.

### Commercial Pumps for Process

**Appendix A – Technical Resource Manual****Ameren Missouri**

Current typical existing market (baseline)	N/A
Minimum threshold for credit	≥ 75% Pump Efficiency Improvement (> 5 HP); for HP < 5, see table below.
Estimated savings 10,000 – 50,000 BTU/h <sup>1</sup>	Average of 236 kWh/HP
Change in usage calculation <sup>2</sup>	$\Delta kWh = kW * t * (1 - \eta_1 / \eta_2)$
Estimated demand savings <sup>1</sup>	Average of 0.064 kW/HP
Measure life <sup>1</sup>	15 years
Incremental Cost <sup>1</sup>	See table below

[1] Taken from Morgan Measure Libraries

[2] Taken from Ohio TRM 2009

\*- If the appropriate field data required to complete this equation cannot be obtained, the deemed savings values in the table are to be used for each measure.

Key Assumptions:

- T = annual hours of operation = 3,680 hours
- Load Factor = LF = 76%.  
 $\eta_1$  = Efficiency of the original pumping system, %  
 $\eta_2$  = Efficiency of the improved pumping system, %

## Appendix A – Technical Resource Manual

## Ameren Missouri

Motor Horsepower	Average Base Efficiency (%)	Average High Efficiency (%)
0.75	59.02	63.58
1	62.10	67.15
2	58.99	65.51
3	59.19	67.30
5	59.41	71.11

Pump HP	Eff Increase	kW Savings	kWh Savings	Increased Cost \$	kW / hp	Incremental Cost
1.5	5.66	0.547067	1,991	\$ 319	0.365	\$ 350.00
2.0	7.48	0.140911	513	\$ 467	0.070	\$ 350.00
3.0	7.19	0.157489	573	\$ 461	0.052	\$ 350.00
5.0	2.86	0.182356	664	\$ 75	0.036	\$ 341.00
5.0	21.3	2.5364	9,232	\$ 304	0.507	\$ 341.00
5.0	12.9	1.210178	4,405	\$ 754	0.242	\$ 341.00
5.0	13.75	0.431022	1,569	\$ 341	0.086	\$ 341.00
5.0	24.54	1.168733	4,254	\$ 610	0.234	\$ 341.00
7.5	7.48	0.505622	1,840	\$ 657	0.067	\$ 498.00
7.5	6.05	0.472467	1,720	\$ 498	0.063	\$ 498.00
10.0	2.96	0.281822	1,026	\$ 131	0.028	\$ 332.00
10.0	4.6	0.4476	1,629	\$ 332	0.045	\$ 332.00
10.0	12.25	1.110711	4,043	\$ 150	0.111	\$ 332.00
15.0	16.09	2.0142	7,332	\$ 585	0.134	\$ 585.00
20.0	2.45	0.348133	1,267	\$ 1,029	0.017	\$ 850.00
20.0	9.24	1.467133	5,340	\$ 498	0.073	\$ 850.00
20.0	4	0.936644	3,409	\$ 850	0.047	\$ 850.00

## Appendix A – Technical Resource Manual

## Ameren Missouri

**Commercial Variable Frequency Drives for Process Pumping (VFD)**

Current typical existing market (baseline)	N/A
Minimum threshold for credit	VFD speed must be automatically controlled by differential pressure, flow, temperature, or other variable signal.
Estimated savings <sup>1</sup>	See Table Below
Change in usage calculation <sup>2</sup>	$\Delta kWh = BHP * 0.746 / \eta_{motor} \times HOURS \times ESF$
Estimated savings <sup>1</sup>	See Table Below
Measure life <sup>1</sup>	15 years
Incremental Cost <sup>1</sup>	See table below

[1] Taken from Morgan Measure Libraries

[2] Taken from Ohio TRM 2009

\*- If the appropriate field data required to complete this equation cannot be obtained, the deemed savings values in the table are to be used for each measure.

## Key Assumptions:

- Hours of operation = see chart below
- The average loading of the pumps analyzed was 86% pump capacity.
- Coincidence Factor (CF) = 0.78
- BHP = Brake horsepower of motor, should be collected with application.
- $\eta_{motor}$  = efficiency of motor being driven by VFD = 59%
- 0.746 = conversion factor HP to kW
- ESF = energy savings factor = 39%<sup>1</sup>

[1] Taken from Morgan Measure Libraries

Size	kWh Savings	kW Savings	Incremental Cost	Hours
3HP	3,246.2	0.686	\$ 1,845	3,713
5 HP	5,356.7	1.143	\$ 2,070	3,676
7.5 HP	8,116.2	1.714	\$ 2,860	3,713
10 HP	10,713.4	2.286	\$ 2,860	3,676
15 HP	16,232.3	3.429	\$ 3,265	3,713
20 HP	21,643.1	4.571	\$ 4,515	3,713
25 HP	27,053.9	5.714	\$ 5,120	3,713
30 HP	32,464.6	6.857	\$ 5,770	3,713
40 HP	43,286.2	9.143	\$ 8,095	3,713
50 HP	54,108.4	11.429	\$ 8,950	3,713

**Commercial Variable Frequency Drives for Air Compressors (VFD)**

Current typical existing market (baseline)	Screw Air Compressor with Modulation Control
Minimum threshold for credit	Screw Air Compressor with Variable Speed Drive (VSD) Control



## Appendix A – Technical Resource Manual

## Ameren Missouri

Estimated savings <sup>1</sup>	5.82 kWh per HP
Estimated demand savings <sup>1</sup>	0.0014 kW per HP
Measure life <sup>1</sup>	15 years
Incremental Cost <sup>1</sup>	\$ 1 per HP

[1] Taken from Morgan Measure Libraries

### Commercial HVAC Applications

To most accurately measure energy and demand savings attributable to heating, ventilation, and air conditioning measures, building simulation modeling should be conducted (see Section 05 below), however, if the resources required to complete building simulation analysis are not available, the following equations can be used to estimate savings. If a measure does not have a savings algorithm associated with it, the deemed values represented in the table should be used.

#### <150 Ton Water Cooled Centrifugal Chiller

Current typical existing market (baseline) <sup>1</sup>	0.70 kW/ton full-load efficiency 0.67 kW/ton IPLV
Minimum threshold for credit <sup>1</sup>	0.56 – 0.70 kW/ton full-load efficiency 0.34 – 0.60 kW/ton IPLV
Estimated savings credit per chiller for 0.56 kW/ton <sup>1</sup>	422 kWh/ton
Change in usage calculation <sup>2</sup>	$\Delta kWh = T(OH)(IPLV_{base} - IPLV_{ee})$
Estimated demand savings credit per chiller for 0.56 kW/ton <sup>1</sup>	0.142 kW/ton
Measure life <sup>1</sup>	20 years 25 years
Incremental Cost <sup>1</sup>	\$ 186/ton

[1] Taken from Morgan Measure Libraries

[2] Taken from AmerenUE Business TRM 2008

\*- If the appropriate field data required to complete this equation cannot be obtained, the deemed savings values in the table are to be used for each measure.

#### Key Assumptions:

- IPLV = Integrated Part Load Factor - The term IPLV is used to signify the cooling efficiency related to a typical (hypothetical) season rather than a single rated condition. The IPLV is calculated by determining the weighted average efficiency at part-load capacities specified by an accepted standard
- T = Capacity of chiller (tons) (assumed 560 tons)
- OH = Equivalent full load annual operating hours (hr)

#### >150 to <300 Ton Water Cooled Centrifugal Chiller

Current typical existing market (baseline) <sup>1</sup>	0.63 kW/ton full-load efficiency 0.60 kW/ton IPLV
Minimum threshold for credit <sup>1</sup>	0.51 – 0.63 kW/ton full-load efficiency 0.30 – 0.54 kW/ton IPLV
Estimated savings credit per chiller for 0.51 kW/ton <sup>1</sup>	375 kWh/ton
Change in usage calculation <sup>2</sup>	$\Delta kWh = T(OH)(IPLV_{base} - IPLV_{ee})$
Estimated demand savings credit per chiller for 0.51 kW/ton <sup>1</sup>	0.128 kW/ton

**Appendix A – Technical Resource Manual****Ameren Missouri**

Measure life <sup>1</sup>	20 years 25 years
Incremental Cost <sup>1</sup>	\$ 143/ton

[1] Taken from Morgan Measure Libraries

[2] Taken from AmerenUE Business TRM 2008

\*- If the appropriate field data required to complete this equation cannot be obtained, the deemed savings values in the table are to be used for each measure.

## Key Assumptions:

- IPLV = Integrated Part Load Factor - The term IPLV is used to signify the cooling efficiency related to a typical (hypothetical) season rather than a single rated condition. The IPLV is calculated by determining the weighted average efficiency at part-load capacities specified by an accepted standard
- T = Capacity of chiller (tons) (assumed 560 tons)
- OH = Equivalent full load annual operating hours (hr)

**>300 Ton Water Cooled Centrifugal Chiller**

Current typical existing market (baseline) <sup>1</sup>	0.58 kW/ton full-load efficiency 0.55 kW/ton IPLV
Minimum threshold for credit <sup>1</sup>	0.46 – 0.58 kW/ton full-load efficiency 0.29 – 0.49 kW/ton IPLV
Estimated savings credit per chiller for 0.46 kW/ton <sup>1</sup>	346 kWh/ton
Change in usage calculation <sup>2</sup>	$\Delta kWh = T(OH)(IPLV_{base} - IPLV_{ee})$
Estimated demand savings credit per chiller for 0.46 kW/ton <sup>1</sup>	0.116 kW/ton
Measure life <sup>1</sup>	20 years 25 years
Incremental Cost <sup>1</sup>	\$ 112/ton

[1] Taken from Morgan Measure Libraries

[2] Taken from AmerenUE Business TRM 2008

\*- If the appropriate field data required to complete this equation cannot be obtained, the deemed savings values in the table are to be used for each measure.

## Key Assumptions:

- IPLV = Integrated Part Load Factor - The term IPLV is used to signify the cooling efficiency related to a typical (hypothetical) season rather than a single rated condition. The IPLV is calculated by determining the weighted average efficiency at part-load capacities specified by an accepted standard
- T = Capacity of chiller (tons) (assumed 560 tons)
- OH = Equivalent full load annual operating hours (hr)

## Appendix A – Technical Resource Manual

## Ameren Missouri

**<150 Ton Water Cooled Screw Chiller**

Current typical existing market (baseline) <sup>1</sup>	0.79 kW/ton full-load efficiency 0.68 kW/ton IPLV
Minimum threshold for credit <sup>1</sup>	0.63 – 0.79 kW/ton full-load efficiency 0.38 – 0.62 kW/ton IPLV
Estimated savings credit per chiller for 0.38 kW/ton <sup>1</sup>	460 kWh/ton
Change in usage calculation <sup>2</sup>	$\Delta kWh = T(OH)(IPLV_{base} - IPLV_{ee})$
Estimated demand savings credit per chiller for 0.78 kW/ton <sup>1</sup>	0.169 kW/ton
Measure life <sup>1</sup>	20 years 25 years
Incremental Cost <sup>1</sup>	\$ 165/ton

[1] Taken from Morgan Measure Libraries

[2] Taken from AmerenUE Business TRM 2008

\*- If the appropriate field data required to complete this equation cannot be obtained, the deemed savings values in the table are to be used for each measure.

## Key Assumptions:

- IPLV = Integrated Part Load Factor - The term IPLV is used to signify the cooling efficiency related to a typical (hypothetical) season rather than a single rated condition. The IPLV is calculated by determining the weighted average efficiency at part-load capacities specified by an accepted standard
- T = Capacity of chiller (tons) (assumed 560 tons)
- OH = Equivalent full load annual operating hours (hr)

**>150 to <300 Ton Water Cooled Screw Chiller**

Current typical existing market (baseline) <sup>1</sup>	0.72 kW/ton full-load efficiency 0.63 kW/ton IPLV
Minimum threshold for credit <sup>1</sup>	0.57 – 0.72 kW/ton full-load efficiency 0.34 – 0.57 kW/ton IPLV
Estimated savings credit per chiller for 0.57 kW/ton <sup>1</sup>	416 kWh/ton
Change in usage calculation <sup>2</sup>	$\Delta kWh = T(OH)(IPLV_{base} - IPLV_{ee})$
Estimated demand savings credit per chiller for 0.57 kW/ton <sup>1</sup>	0.154 kW/ton
Measure life <sup>1</sup>	20 years 25 years
Incremental Cost <sup>1</sup>	\$ 125/ton

[1] Taken from Morgan Measure Libraries

[2] Taken from AmerenUE Business TRM 2008

\*- If the appropriate field data required to complete this equation cannot be obtained, the deemed savings values in the table are to be used for each measure.

**Appendix A – Technical Resource Manual****Ameren Missouri**

## Key Assumptions:

- IPLV = Integrated Part Load Factor - The term IPLV is used to signify the cooling efficiency related to a typical (hypothetical) season rather than a single rated condition. The IPLV is calculated by determining the weighted average efficiency at part-load capacities specified by an accepted standard
- T = Capacity of chiller (tons) (assumed 560 tons)
- OH = Equivalent full load annual operating hours (hr)

**>300 Ton Water Cooled Screw Chiller**

Current typical existing market (baseline) <sup>1</sup>	0.64 kW/ton full-load efficiency 0.57 kW/ton IPLV
Minimum threshold for credit <sup>1</sup>	0.51 – 0.64 kW/ton full-load efficiency 0.31 – 0.51 kW/ton IPLV
Estimated savings credit per chiller for 0.51 kW/ton <sup>1</sup>	373 kWh/ton
Change in usage calculation <sup>2</sup>	$\Delta kWh = T(OH)(IPLV_{base} - IPLV_{ee})$
Estimated demand savings credit per chiller for 0.51 kW/ton <sup>1</sup>	0.137 kW/ton
Measure life <sup>1</sup>	20 years 25 years
Incremental Cost <sup>1</sup>	\$ 93/ton

[1] Taken from Morgan Measure Libraries

[2] Taken from AmerenUE Business 2008 TRM

\*- If the appropriate field data required to complete this equation cannot be obtained, the deemed savings values in the table are to be used for each measure.

## Key Assumptions:

- IPLV = Integrated Part Load Factor - The term IPLV is used to signify the cooling efficiency related to a typical (hypothetical) season rather than a single rated condition. The IPLV is calculated by determining the weighted average efficiency at part-load capacities specified by an accepted standard
- T = Capacity of chiller (tons) (assumed 560 tons)
- OH = Equivalent full load annual operating hours (hr)

**Unitary Air Conditioner <65,000 BTU/hr**

Current typical existing market (baseline) <sup>2</sup>	SEER 13
Minimum threshold for credit	SEER 14
Estimated savings credit <sup>1</sup>	65.23 kWh/ton
Change in usage calculation <sup>3</sup>	$\Delta kWh = (BtuH/1000) \times (1/EER_b - 1/EER_q) \times EFLH^*$
Estimated demand savings credit <sup>1</sup>	0.0746 kW/ton
Measure life <sup>1</sup>	15 years
Incremental Cost <sup>1</sup>	\$ 55.57/ton

[1] Taken from Morgan Measure Libraries

[2] Taken from National Appliance Energy Conservation Act (NAECA)

[3] Taken from AmerenUE Business TRM 2008

\*- If the appropriate field data required to complete this equation cannot be obtained, the deemed savings values in the table are to be used for each measure.

## Appendix A – Technical Resource Manual

## Ameren Missouri

### Key Assumptions:

- BtuH = Cooling capacity in Btu/Hour – This value comes from ARI or AHAM rating or manufacturer data.
- EERb = Efficiency rating of the baseline unit. For units < 65,000, SEER and HSPF should be used for cooling and heating savings, respectively = 13 SEER
- EERq = Efficiency rating of the High Efficiency unit – This value comes from the ARI or AHAM directories or manufacturer data. For units < 65,000, SEER and HSPF should be used for cooling and heating savings, respectively = 14 SEER.
- CF = Coincidence Factor – This value represents the percentage of the total load which is on during electric system's Peak. This value will be based on existing measured usage and determined as the average number of operating hours during the peak period.
- EFLH = Equivalent Full Load Hours – This represents a measure of energy use by season during the on-peak and off peak periods. This value will be determined by existing measured data of kWh during the period divided by kW at design conditions

### Unitary Air Conditioner <135,000 to <240,000 BTU/hr (3 phase)

Current typical existing market (baseline) <sup>2</sup>	9.5 EER
Minimum threshold for credit	11.0 EER
Estimated savings credit <sup>1</sup>	119 kWh/ton
Change in usage calculation <sup>3</sup>	$\Delta\text{kWh} = (\text{BtuH}/1000) \times (1/\text{EERb} - 1/\text{EERq})$ X EFLH *
Estimated demand savings credit <sup>1</sup>	0.136 kW/ton
Measure life <sup>1</sup>	15 years
Incremental Cost <sup>1</sup>	\$ 110.89/ton

[1] Taken from Morgan Measure Libraries

[2] Taken from American Society of Heating, Refrigerating and Air-Conditioning Engineers (ASHRAE) 90.1-2004

[3] Taken AmerenUE Business TRM 2008

\*- If the appropriate field data required to complete this equation cannot be obtained, the deemed savings values in the table are to be used for each measure.

### Key Assumptions:

- BtuH = Cooling capacity in Btu/Hour – This value comes from ARI or AHAM rating or manufacturer data.
- EERb = Efficiency rating of the baseline unit. For units < 65,000, SEER and HSPF should be used for cooling and heating savings, respectively = 9.5 EER
- EERq = Efficiency rating of the High Efficiency unit – This value comes from the ARI or AHAM directories or manufacturer data. For units < 65,000, SEER and HSPF should be used for cooling and heating savings, respectively = 11 EER.
- CF = Coincidence Factor – This value represents the percentage of the total load which is on during electric system's Peak. This value will be based on existing measured usage and determined as the average number of operating hours during the peak period.
- EFLH = Equivalent Full Load Hours – This represents a measure of energy use by season during the on-peak and off peak periods. This value will be determined by existing measured data of kWh during the period divided by kW at design conditions

## Appendix A – Technical Resource Manual

## Ameren Missouri

### Unitary Air Conditioner >760,000 BTU/hr (3 phase)

Current typical existing market (baseline) <sup>2</sup>	9.0 EER
Minimum threshold for credit	10.0 EER
Estimated savings credit <sup>1</sup>	92.12 kWh/ton
Change in usage calculation <sup>3</sup>	$\Delta\text{kWh} = (\text{BtuH}/1000) \times (1/\text{EERb}-1/\text{EERq})$ $\times \text{EFLH}^*$
Estimated demand savings credit <sup>1</sup>	0.105 kW/ton
Measure life <sup>1</sup>	15 years
Incremental Cost <sup>1</sup>	\$ 98.38/ton

[1] Taken from Morgan Measure Libraries

[2] Taken from ASHRAE 90.1-2004

[3] Taken from AmerenUE Business TRM 2008

\*- If the appropriate field data required to complete this equation cannot be obtained, the deemed savings values in the table are to be used for each measure.

#### Key Assumptions:

- BtuH = Cooling capacity in Btu/Hour – This value comes from ARI or AHAM rating or manufacturer data.
- EERb = Efficiency rating of the baseline unit. For units < 65,000, SEER and HSPF should be used for cooling and heating savings, respectively = 9 EER
- EERq = Efficiency rating of the High Efficiency unit – This value comes from the ARI or AHAM directories or manufacturer data. For units < 65,000, SEER and HSPF should be used for cooling and heating savings, respectively = 10 EER.
- CF = Coincidence Factor – This value represents the percentage of the total load which is on during electric system's Peak. This value will be based on existing measured usage and determined as the average number of operating hours during the peak period.
- EFLH = Equivalent Full Load Hours – This represents a measure of energy use by season during the on-peak and off peak periods. This value will be determined by existing measured data of kWh during the period divided by kW at design conditions

### Ground Source Heat Pump <135,000 BTU/hr

Current typical existing market (baseline) <sup>1</sup>	13.4 EER
Minimum threshold for credit <sup>1</sup>	17 EER
Estimated savings credit <sup>1</sup>	240 kWh/ton
Change in usage calculation <sup>2</sup>	$\Delta\text{kWh} = (\text{BtuH}/1000) \times (1/\text{EERb}-1/\text{EERq})$ $\times \text{EFLH}^*$
Estimated demand savings <sup>1</sup>	0.114 kW/ton
Measure life <sup>1</sup>	15 years
Incremental Cost <sup>1</sup>	\$ 180/ton

[1] Taken from Morgan Measure Libraries

[2] Taken from AmerenUE Business TRM 2008

\*- If the appropriate field data required to complete this equation cannot be obtained, the deemed savings values in the table are to be used for each measure.

#### Key Assumptions:

**Appendix A – Technical Resource Manual****Ameren Missouri**

- BtuH = Cooling capacity in Btu/Hour – This value comes from ARI or AHAM rating or manufacturer data.
- EERb = Efficiency rating of the baseline unit. For units < 65,000, SEER and HSPF should be used for cooling and heating savings, respectively = 13.4 EER
- EERq = Efficiency rating of the High Efficiency unit – This value comes from the ARI or AHAM directories or manufacturer data. For units < 65,000, SEER and HSPF should be used for cooling and heating savings, respectively = 17 EER.
- CF = Coincidence Factor – This value represents the percentage of the total load which is on during electric system's Peak. This value will be based on existing measured usage and determined as the average number of operating hours during the peak period.
- EFLH = Equivalent Full Load Hours – This represents a measure of energy use by season during the on-peak and off peak periods. This value will be determined by existing measured data of kWh during the period divided by kW at design conditions

**Ground Source Heat Pump <135,000 BTU/hr**

Current typical existing market (baseline) <sup>1</sup>	13.4 EER
Minimum threshold for credit <sup>1</sup>	19 EER
Estimated savings credit <sup>1</sup>	305 kWh/ton
Change in usage calculation <sup>2</sup>	$\Delta kWh = (BtuH/1000) \times (1/EERb - 1/EERq) \times EFLH *$
Estimated demand savings credit <sup>1</sup>	0.147 kW/ton
Measure life <sup>1</sup>	15 years
Incremental Cost <sup>1</sup>	\$ 180/ton

[1] Taken from Morgan Measure Libraries

[2] Taken from AmerenUE Business TRM 2008

\*- If the appropriate field data required to complete this equation cannot be obtained, the deemed savings values in the table are to be used for each measure.

**Key Assumptions:**

- BtuH = Cooling capacity in Btu/Hour – This value comes from ARI or AHAM rating or manufacturer data.
- EERb = Efficiency rating of the baseline unit. For units < 65,000, SEER and HSPF should be used for cooling and heating savings, respectively = 13.4 EER
- EERq = Efficiency rating of the High Efficiency unit – This value comes from the ARI or AHAM directories or manufacturer data. For units < 65,000, SEER and HSPF should be used for cooling and heating savings, respectively = 19 EER.
- CF = Coincidence Factor – This value represents the percentage of the total load which is on during electric system's Peak. This value will be based on existing measured usage and determined as the average number of operating hours during the peak period.
- EFLH = Equivalent Full Load Hours – This represents a measure of energy use by season during the on-peak and off peak periods. This value will be determined by existing measured data of kWh during the period divided by kW at design conditions

**Heat Pump <65,000 BTU/hr**

Current typical existing market (baseline) <sup>1</sup>	13.0 SEER, 7.7 HSPF
Minimum threshold for credit <sup>1</sup>	14 SEER, 7.97 HSPF
Estimated savings credit <sup>2</sup>	114 kWh/ton

**Appendix A – Technical Resource Manual****Ameren Missouri**

Change in usage calculation <sup>2</sup>	See equation below.
Estimated demand savings credit <sup>1</sup>	0.079 kW/ton
Measure life <sup>1</sup>	15 years
Incremental Cost <sup>1</sup>	\$ 73.5/ton

[1] Taken from Morgan Measure Libraries

[2] Ohio TRM 2009

\*- If the appropriate field data required to complete this equation cannot be obtained, the deemed savings values in the table are to be used for each measure.

For units with cooling capacities less than 65 kBtu/h:

Annual kWh Savings = Annual kWh Savingscool + Annual kWh Savingsheat

Annual kWh Savingscool = (kBtu/h) \* [(1/SEERbase) – (1/SEERee)] \* EFLHcool

Annual kWh Savingsheat = (kBtu/h) \* [(1/HSPFbase) – (1/HSPFee)] \* EFLHheat

Summer Coincident Peak kW Savings = (kBtu/h) \* [(1/EERbase) – (1/EERee)] \* CF

Key Assumptions:

- kBtu/hcool = capacity of the cooling equipment in kBtu per hour (1 ton of cooling capacity equals 12 kBtu/h). = Actual installed
- SEERbase = Seasonal Energy Efficiency Ratio of the baseline equipment; see table below for values.
- SEERee = Seasonal Energy Efficiency Ratio of the energy efficient equipment.
- = Actual installed
- EFLHcool = cooling mode equivalent full load hours; see table below for default values
- HSPFbase = Heating Seasonal Performance Factor of the baseline equipment; see table above for values.
- HSPFee = Heating Seasonal Performance Factor of the energy efficient equipment.
- = Actual installed
- EFLHheat = heating mode equivalent full load hours; see table above for default values.
- kBtu/hheat = capacity of the heating equipment in kBtu per hour.
- = Actual installed
- 3412= Btu per Wh.

**Heat Pump >135,000 to <240,000 BTU/hr**

Current typical existing market (baseline) <sup>1</sup>	9.1 EER
Minimum threshold for credit <sup>1</sup>	10 EER
Estimated savings credit <sup>1</sup>	143 kWh/ton
Change in usage calculation <sup>2</sup>	$\Delta\text{kWh} = (\text{BtuH}/1000) \times (1/\text{EERb} - 1/\text{EERq}) \times \text{EFLH} *$
Estimated demand savings credit <sup>1</sup>	0.095 kW/ton
Measure life <sup>1</sup>	15 years
Incremental Cost <sup>1</sup>	\$ 125/ton

[1] Taken from Morgan Measure Libraries

[2] Taken from AmerenUE Business TRM 2008

\*- If the appropriate field data required to complete this equation cannot be obtained, the deemed savings values in the table are to be used for each measure.

Key Assumptions:



**Appendix A – Technical Resource Manual****Ameren Missouri**

- BtuH = Cooling capacity in Btu/Hour – This value comes from ARI or AHAM rating or manufacturer data.
- EERb = Efficiency rating of the baseline unit. For units < 65,000, SEER and HSPF should be used for cooling and heating savings, respectively = 9.1 EER
- EERq = Efficiency rating of the High Efficiency unit – This value comes from the ARI or AHAM directories or manufacturer data. For units < 65,000, SEER and HSPF should be used for cooling and heating savings, respectively = 10 EER.
- CF = Coincidence Factor – This value represents the percentage of the total load which is on during electric system's Peak. This value will be based on existing measured usage and determined as the average number of operating hours during the peak period.
- EFLH = Equivalent Full Load Hours – This represents a measure of energy use by season during the on-peak and off peak periods. This value will be determined by existing measured data of kWh during the period divided by kW at design conditions

**Heat Pump >240,000 BTU/hr**

Current typical existing market (baseline) <sup>1</sup>	8.8 EER
Minimum threshold for credit <sup>1</sup>	10 EER
Estimated savings credit <sup>2</sup>	175 kWh/ton
Change in usage calculation <sup>2</sup>	$\Delta\text{kWh} = (\text{BtuH}/1000) \times (1/\text{EERb}-1/\text{EERq}) \times \text{EFLH}^*$
Estimated demand savings credit <sup>1</sup>	0.130 kW/ton
Measure life <sup>1</sup>	15 years
Incremental Cost <sup>1</sup>	\$ 130/ton

[1] Taken from Morgan Measure Libraries

[2] Taken from AmerenUE Business TRM 2008

\*- If the appropriate field data required to complete this equation cannot be obtained, the deemed savings values in the table are to be used for each measure.

**Key Assumptions:**

- BtuH = Cooling capacity in Btu/Hour – This value comes from ARI or AHAM rating or manufacturer data.
- EERb = Efficiency rating of the baseline unit. For units < 65,000, SEER and HSPF should be used for cooling and heating savings, respectively = 8.8 EER
- EERq = Efficiency rating of the High Efficiency unit – This value comes from the ARI or AHAM directories or manufacturer data. For units < 65,000, SEER and HSPF should be used for cooling and heating savings, respectively = 10 EER.
- CF = Coincidence Factor – This value represents the percentage of the total load which is on during electric system's Peak. This value will be based on existing measured usage and determined as the average number of operating hours during the peak period.
- EFLH = Equivalent Full Load Hours – This represents a measure of energy use by season during the on-peak and off peak periods. This value will be determined by existing measured data of kWh during the period divided by kW at design conditions

**Appendix A – Technical Resource Manual****Ameren Missouri*****Guest Room Energy Management System – Electric Heating (Hotel/Lodging)***

Current typical Hotel Room Energy Management System <sup>1</sup>	Manual Controls
Minimum threshold for credit <sup>1</sup>	Keycard occupancy sensors and passive infrared occupancy sensors
Estimated savings credit <sup>1</sup>	1,112 kWh per room
	See equation below
Estimated demand savings credit <sup>1</sup>	.0.088 kW
Measure life <sup>1</sup>	9 years
Incremental Cost <sup>1</sup>	\$ 600 per room

[1] Taken from Morgan Measure Libraries

**Appendix A – Technical Resource Manual****Ameren Missouri**

## Key Assumptions

- Tons = 1,900 square foot home

**Commercial Miscellaneous****Tractor Heater Timers**

Current typical existing market (baseline) <sup>1</sup>	N/A
Minimum threshold for credit <sup>1</sup>	N/A
Estimated savings credit <sup>1</sup>	576 kWh
Change in usage calculation <sup>1</sup>	
Measure life <sup>1</sup>	10 years
Incremental Cost <sup>1</sup>	\$ 35

[1] Taken from Focus on Energy Evaluation Business Programs: Deemed Savings Manual v1.0 March 22, 2010.

For custom – application specific, see Ohio TRM language/Lockheed Martin how they analyze projects.

\*- If the appropriate field data required to complete this equation cannot be obtained, the deemed savings values in the table are to be used for each measure.

## Key Assumptions:

- P = average power of engine block heater = 1,000\_watts
- Hours – reduction in hours block heater is used = 8 hours
- Days = number of operating days per year = 90 days
- UF = usage fraction = 0.8

**Desktop Virtualization – Thin Client 2**

<u>Current typical existing market (baseline)<sup>1</sup></u>	<u>Energy Star 3.0 desktop computer</u>
<u>Minimum threshold for credit<sup>1</sup></u>	<u>Hardware/Software replacing desktop</u>
<u>Estimated savings credit<sup>1</sup></u>	<u>541 kWh</u>
<u>Estimated demand savings credit<sup>1</sup></u>	<u>0.070 kW</u>
<u>Measure life<sup>1</sup></u>	<u>5 years</u>
<u>Incremental Cost<sup>1</sup></u>	<u>\$ 116</u>

[1] Information taken from Xcel Minnesota TRM.

$$kWh\ savings = (Base\ UEC * AOH - Efficient\ UEC * AOH) / 1000$$

## Key Assumptions:

- Annual Hours of Operation (AOH) = 7,311
- Baseline Energy Consumption = 96 watts
- Efficient Energy Consumption = 22 watts

Due to the progressive nature of this measure, EM&V activities will be undertaken to verify this measure's assumptions in this first MEEIA cycle.

Formatted: Centered

Formatted: List Paragraph, Bulleted + Level: 1 + Aligned at: 0.25" + Indent at: 0.5"

## Appendix A – Technical Resource Manual

## Ameren Missouri

Energy Star Personal Computer (PC)

<u>Current typical existing market (baseline)<sup>1</sup></u>	<u>Desktop computer meeting ENERGY STAR 3.0 with a standard efficiency power supply</u>
<u>Minimum threshold for credit<sup>1</sup></u>	<u>ENERGY STAR 5.0 Desktop Computer</u>
<u>Estimated savings credit<sup>1</sup></u>	<u>149 kWh</u>
<u>Estimated demand savings credit<sup>1</sup></u>	<u>0.030 kW</u>
<u>Measure life<sup>1</sup></u>	<u>4 years</u>
<u>Incremental Cost<sup>1</sup></u>	<u>\$ 25</u>

[1] Taken from Lockheed Martin proposal October 2012. Information taken from Energy Star Calculator.

$$\text{kWh savings} = \text{Base UEC} - \text{Efficient UEC}$$

## Appendix A – Technical Resource Manual

## Ameren Missouri

**PC Power Management Software**

<u>Current typical existing market (baseline)<sup>1</sup></u>	<u>Desktop PC, not centrally power managed</u>
<u>Minimum threshold for credit<sup>1</sup></u>	<u>Centrally power managed</u>
<u>Estimated savings credit<sup>1</sup></u>	<u>200 kWh</u>
<u>Estimated demand savings credit<sup>1</sup></u>	<u>0.000 kW</u>
<u>Measure life<sup>1</sup></u>	<u>4 years</u>
<u>Incremental Cost<sup>1</sup></u>	<u>\$ 20</u>

[1] Taken from Lockheed Martin proposal October 2012.

Key Assumptions:

- Energy savings of typical PC usage in hospital, small office, large office and school setting was analyzed.
- The term “PC”, “Computer”, or “end point” refers to a single-user computer as it is defined by EPA’s Program Requirements for Computers, Version 5.0.

**Window Replacement**

<u>Current typical existing market (baseline)<sup>1</sup></u>	<u>International Energy Conservation Code (IECC) 2004</u>
<u>Minimum threshold for credit<sup>1</sup></u>	<u>Above IECC 2009</u>
<u>Estimated savings credit<sup>1</sup></u>	<u>30,575 kWh</u>
<u>Estimated savings credit</u>	<u>6.413 kW</u>
<u>Measure life<sup>1</sup></u>	<u>20 years</u>
<u>Incremental Cost<sup>1</sup></u>	<u>\$ 13,394</u>

[1] Taken Morgan Measure Libraries (GEP Potential Study Measure list)

Key Assumptions:

- Savings are on a per building basis.

**Commercial Optimization Measures****Chilled Water Reset Controls**

<u>Current typical existing market (baseline)</u>	<u>45°F fixed chilled-water temperature setpoint</u>
<u>Minimum threshold for credit</u>	<u>Reset water temperature to increase by 5 or 10 degrees</u>
<u>Estimated savings for 5 degree reset<sup>1</sup></u>	<u>74 kWh/ton</u>
<u>Estimated savings for 10 degree reset<sup>1</sup></u>	<u>89 kWh/ton</u>
<u>Estimated demand savings for 5 degree reset<sup>1</sup></u>	<u>0.0058 kW/ton</u>
<u>Estimated demand savings for 10 degree reset<sup>2</sup></u>	<u>0.00640369 kW/ton</u>
<u>Measure life<sup>1</sup></u>	<u>5 years</u>
<u>Incremental Cost<sup>1</sup></u>	<u>\$ 0.80 per ton</u>

[1] Taken from Morgan Measure Libraries

**Appendix A – Technical Resource Manual****Ameren Missouri**

## Key Assumptions:

- Tons = 612.4
- Total kWh savings for 5 degree reset = 45,821.1 kWh
- Total kW savings for 5 degree rest = 3.580 kW
- Total kWh savings for 10 degree rest = 54,362.9 kWh
- Total kW savings for 10 degree reset = 3.928 k

**Energy Management System**

Current typical existing market (baseline)	Constant chilled water temperature setpoint, loop pumps operating 24/7
Minimum threshold for credit	Chilled water temperature setback and on/off scheduling of loop pumps
<u>Estimated savings credit<sup>1</sup> Estimated savings for 5 degree reset<sup>4</sup></u>	0.832 kWh per ft <sup>2</sup>
<u>Estimated demand savings credit<sup>1</sup> Estimated savings for 40 degree reset<sup>4</sup></u>	0.000083283 per ft <sup>2</sup>
Measure life <sup>1</sup>	15 years
Incremental Cost <sup>1</sup>	\$ 0.32 per ft <sup>2</sup>

[1] Taken from Morgan Measure Libraries

## Key Assumptions:

- Tons = 612.4
- Total kWh savings for 5 degree reset = 45,821.1 kWh
- Total kW savings for 5 degree rest = 3.580 kW
- Total kWh savings for 10 degree rest = 54,362.9 kWh
- Total kW savings for 10 degree reset = 3.928 kW

**Refrigerant Charging Correction**

Current typical existing market (baseline)	Cooling capacity and EIR degraded by 10% to reflect “typical” refrigerant charge
Minimum threshold for credit	Standard cooling performance – proper refrigerant charge; 10% EER improvement
Estimated savings credit <sup>1</sup>	96.19 kWh per ft <sup>2</sup>
Estimated demand savings credit <sup>1</sup>	0.11 kW per ft <sup>2</sup>
Measure life <sup>1</sup>	10 years
Incremental Cost <sup>1</sup>	\$ 38.35 per ft <sup>2</sup>

[1] Taken from Morgan Measure Libraries

## Key Assumptions:

- Tons = 235.8
- Total kWh savings for 10% EER improvement = 22,680.5kWh
- Total kW savings for 10% EER improvement = 26.075 kW

## Appendix A – Technical Resource Manual

## Ameren Missouri

**Optimized ~~Process~~ Cooling Controls**

Current typical existing market (baseline)	<del>Manual/Standard</del> Digital Control of Cooling Systems <u>(Basic)</u>
Minimum threshold for credit	<u>Optimize to achieve</u> 10% Improvement in building's cooling load
<u>Estimated savings credit<sup>1</sup> Estimated savings for 5-degree reset<sup>+</sup></u>	16,325 kWh
<u>Estimated demand savings credit<sup>1</sup> Estimated savings for 40-degree reset<sup>+</sup></u>	0.2.238 kW
Measure life <sup>1</sup>	15 years
Incremental Cost <sup>1</sup>	\$ 1,568 per project

[1] Taken from Morgan Measure Libraries (Cadmus Potential Study Measure list)

## Key Assumptions:

- Assumes 10% savings of building's cooling energy consumption by ~~installing~~ optimizing the building's existing Digital Control System

**Optimized ~~Process~~ Heating Controls**

Current typical existing market (baseline)	<del>Manual/Standard</del> Digital Control of Heating Systems <u>(Basic)</u>
Minimum threshold for credit	<u>Optimize to achieve</u> 10% Improvement in building's heating load
<u>Estimated savings credit<sup>1</sup> Estimated savings for 5-degree reset<sup>+</sup></u>	7,053 kWh
<u>Estimated demand savings credit<sup>1</sup> Estimated savings for 40-degree reset<sup>+</sup></u>	0.967 kW
Measure life <sup>1</sup>	15 years
Incremental Cost <sup>1</sup>	\$ 760 per project

[1] Taken from Morgan Measure Libraries (Cadmus Potential Study Measure list)

## Key Assumptions:

- Assumes 10% savings of building's heating energy consumption by ~~installing~~ optimizing the building's existing Digital Control System

**Compressed Air Optimization**

Current typical existing market (baseline)	N/A
Minimum threshold for credit	20% Improvement in air compressor energy consumption
<u>Estimated savings credit<sup>1</sup> Estimated savings for 5-degree reset<sup>+</sup></u>	200 kWh
<u>Estimated demand savings credit<sup>1</sup> Estimated savings for 40-degree reset<sup>+</sup></u>	0.026 kW
Measure life <sup>1</sup>	10 years

Incremental Cost <sup>1</sup>	\$ 16 per project
-------------------------------	-------------------

[1] Taken from Morgan Measure Libraries (ICF Program Model)

Key Assumptions:

- Assumes 20% improvement over base case

### Custom Project Analysis Methodology<sup>7</sup>

The C&I Custom projects typically require substantial analytic rigor to identifying project savings and costs. While the nature of Custom projects can vary dramatically, most commonly found Custom measures can be grouped into 14 categories:

- Lighting Improvements (fixture upgrades, except for exit signs and controls)
- Lighting Improvements (Exit signs and controls)
- Packaged Air-Conditioners and Heat Pumps (includes RTUs, ASHPs, WSHPs, GSHPs)
- Chiller Replacements
- Cooling Tower Replacements
- Refrigeration System Replacements
- Motor Drive Installations (i.e. variable-frequency drives [VFDs] )
- Compressed-Air Systems
- Controls and Energy Management Systems (EMS)
- Domestic Water Heating (various options)
- Pump, Fan, Piping, and Duct Improvements
- Process Upgrades
- All Other

Some measures involve replacing an item of equipment with a similar, more-efficient model, while others entail enhancing the performance of existing equipment. For example, a measure may consist of modifying the programming of a control system and perhaps also adding one or more sensors and/or circuit-control devices, or it may involve modifying an existing pump or changing a piping system to reduce pressure drop, such that the motor driving the pump draws less power.

In the case of eligible motor upgrades and the installation of Variable Frequency Drive (VFD) drives on motors, this category will be credited with the savings irrespective of where the motor is located, unless the motor is part of a new item of equipment. For example, replacing the motor driving a fan on a cooling tower is a Motor measure, but replacing the entire cooling tower, which includes a new fan motor, is a Cooling Tower Measure.

A Technical Analysis Study (TAS) or energy savings estimate is required for all Custom projects. An energy savings estimate can be provided by the customer or a contractor. The Program engineering staff will review all TAS reports and energy savings estimates to ensure all assumptions are reasonable and that the study is based on sound engineering methodology. When a TAS Report, it will contain complete documentation for the proposed project, and forms a vital element for the subsequent Impact Evaluation performed by the evaluation contractor. The TAS is also often used by the customer to get funding approval. More specifically, the TAS:

- Identifies the customer (organization), key customer representatives and their contact information, and the location of the facility that will host the proposed project.

<sup>7</sup> Taken from Technical Resource Manual for AmerenUE – Business Energy Efficiency 2008 – 2011. Drafted by Lockheed Martin Energy Services.



- Describes the host facility (typically with a photograph and/or sketch showing site layout or floor plan).
- Documents monthly electricity use, and identifies Ameren Missouri account number and meter number.
- Describes the baseline equipment and provides its electricity-use (with estimated load shape<sup>8</sup>) and estimated annual O&M costs.
- Describes the new equipment to be added, together with key performance specifications and expected lifetime, or otherwise completes the description of the measure (i.e., Energy Management System (EMS) reprogramming and new control functions).
- Provides estimated electricity-use (and estimated load shape) for the retrofit condition.
- Provides the energy and demand savings calculations,<sup>9</sup> together with 1) the source of input parameter numbers, and 2) justification for each assumption made.
- Provides the cost to implement the project, together with a cost breakdown and, when possible, written quotations for major equipment item(s) and estimates of ongoing annual O&M costs.
- Provides the estimated financial incentive and estimated annual cost savings, together with the financial metric(s) requested by the customer (i.e., simple payback, IRR, ROI).

As it is noted above, some measures may involve modifying existing controls or energy management systems so they perform more functions and act more effectively to minimize electricity use while still producing the desired or needed service outputs as a function of time. Examples include the installation of Variable Air Volume (VAV) fans and sensors and the installation of a multistage efficient chiller, with each of these new systems controlled by an existing energy management system. This type of project will involve reprogramming of the EMS for the new control functions. *It is most important that the TAS fully describe the new equipment recommended, the new ventilation and chiller controls strategies to be implemented, and the specific EMS control functions that require reprogramming.*

After the TAS is submitted together with an application signed by the customer that references the TAS, an engineer on the Program staff will formally review it and independently check the savings calculations. The TAS will either be approved or returned to the customer with a written explanation of what modifications are needed. When modifications are required, the revision number and date are noted on the cover, new signatures are affixed, and the TAS is resubmitted.

After final approval, the customer is authorized to proceed with implementing the project. Program staff will monitor progress and offer advice if this is needed and it is feasible for program staff to provide this assistance.

#### **Calculating Custom Energy and Demand Savings**

The equations used in this protocol assume that the project has a single measure. If the project has multiple measures, these calculations shall be repeated for each measure in such a way as to capture interactive effects.

#### **Lighting Improvements**

This measure category involves a retrofit of the lighting system at C&I facilities. Typically, these facilities have a significant lighting end-use consumption, and will have ceiling or high-bay lighting fixtures and

<sup>8</sup> Load shape expressed as monthly kWh and kW.

<sup>9</sup> Reductions in Greenhouse Gas emissions or other environmental data should be included when available.

## Appendix A – Technical Resource Manual

## Ameren Missouri

exterior lighting in the parking areas as well for advertising and security. Typical replacement HID or T-8 linear fluorescent high output fixtures are high output T-8 or T-5 linear fluorescent fixtures. Additionally, in areas with variable occupancy, motion sensors can be employed to reduce the operating hours of the lighting equipment.

**Baseline Calculations:** An audit is performed to determine the total number of fixtures per lamp/ballast combination. The lighting system demand (kW) is typically derived from Standard Fixture Wattage Tables. This table is an average of wattages for lamp/ballast combinations from several lighting manufacturers. The energy consumption for each line item is calculated with the following equation:

$$\text{kWh} = \text{WATTS}_{\text{base}} * \text{HOURS} * \text{IF} / 1000$$

Where:

WATTS<sub>base</sub> = Baseline lighting system wattage  
 HOURS = Lighting equipment annual operating hours (hrs)

**Energy Savings:** The methodology to estimate the retrofit energy consumption is identical to the calculation described above for the baseline. The retrofit demand (kW) consumption is more likely to utilize manufacturer's specifications. If lighting controls are part of the measure, the percent hour's reduction will be estimated based on observations of facility occupancy patterns, interviews with facility personnel, and/or standard reductions used in current California Utility Customized Incentive Programs.

$$\text{kWh} = \text{WATTS}_{\text{ee}} * \text{HOURS} * \text{IF} / 1000$$

Where:

WATTS<sub>ee</sub> = Efficient lighting system wattage  
 HOURS = Lighting equipment annual operating hours (hrs)

The energy savings result for the baseline consumption less the total retrofit consumption, with interaction effects factored in are:

$$\Delta \text{kWh} = ((\text{WATTS}_{\text{base}} - \text{WATTS}_{\text{ee}}) * \text{HOURS} * \text{IF}) / 1000$$

**Demand Reduction** - Demand savings result when the demand of the system is reduced during the summer peak period. Since the lighting system is non-weather dependent, the demand reduction is constant throughout the year. Any reduction in demand due to controls will only be included if significant variable occupancy will be achieved during the peak summer period. In this instance, the proportional retrofit demand will be included based on the expected reduction in hours.

$$\Delta \text{kW} = ((\text{WATTS}_{\text{base}} - \text{WATTS}_{\text{ee}}) * \text{CF} * \text{IF}) / 1000$$

The following list defines the various terms that appear in the foregoing equations:

CF = Coincidence Factor (fraction of the maximum power draw of all equipment involved in the measure that occurs during Ameren Missouri's peak system demand period)

IF = Interactive factor (additional savings attributable to reduction in heating or cooling costs associated with the new efficient technology).

### HVAC Direct Expansion (DX)

It is recommended that savings be estimated using a computer simulation (eQuest or DOE-2), but as an alternative the savings can be calculated using the following method:

$$\Delta \text{kW} = (\text{BtuH}/1000) * (1/\text{EERb} - 1/\text{EERq}) * \text{CF}$$

$$\Delta \text{kWh} = (\text{BtuH}/1000) * (1/\text{EERb} - 1/\text{EERq}) * \text{EFLH}$$

Definition of Variables:

- BtuH = Cooling capacity in Btu/Hour – This value comes from ARI or AHAM rating or manufacturer data.
- EERb = Efficiency rating of the baseline unit. This data is found in the HVAC and Heat Pump verification summary table. For units < 65,000, SEER and HSPF should be used for cooling and heating savings, respectively.
- EERq = Efficiency rating of the High Efficiency unit – This value comes from the ARI or AHAM directories or manufacturer data. For units < 65,000, SEER and HSPF should be used for cooling and heating savings, respectively.
- CF = Coincidence Factor – This value represents the percentage of the total load which is on during electric system's Peak Window. This value will be based on existing measured usage and determined as the average number of operating hours during the peak window period.
- EFLH = Equivalent Full Load Hours – This represents a measure of energy use by season during the on-peak and off peak periods. This value will be determined by existing measured data of kWh during the period divided by kW at design conditions.

### Chillers

This measure involves replacing an existing chiller with a high efficiency chiller. Energy is saved as a result of increasing the efficiency of the chiller system.

**Baseline Calculation:** There have been significant advancements in recent years in the efficiency of cooling equipment. The simple baseline calculation is to utilize the full load efficiency from the chiller manufacturer's specifications. This is considered a conservative calculation since more savings are likely achieved during part load conditions. The equation for this calculation is:

$$kWh_{Base} = T(OH)(\eta_{Ex})$$

Where:

kWh <sub>Base</sub>	=	Energy consumption of existing equipment (kWh)
T	=	Capacity of chiller (tons)
OH	=	Equivalent full load annual operating hours (hr)
$\eta_{Ex}$	=	Full load efficiency of existing chiller (kW/ton)

A complex analysis requires a distribution of operation at part load conditions. The efficiency of the chiller will change depending on the percent loading on the chiller. Manufacturer's specifications may include part load efficiencies. Alternatively, ASHRAE 90.1 generic chiller curves can be used to develop part-load efficiencies.

For weather-dependent loads, a weather BIN analysis is a common method to apply accurate operating hours within part load conditions. Typical Meteorological Year (TMY) weather data should be examined in comparison with trend data to evaluate the chiller load and annual hours in each weather BIN. In many industrial facilities, the chiller load is dependent on the production. In this case, production records can be used in conjunction with trend data to develop the annual load profile.

Alternatively, if trend data does not exist, assumption can be made based on interviews with facility personnel and observations of chiller operation during facility audits. The equation above is carried out in each load bin.

$$kWh_{Base} = \sum T(OH)(\eta_{Ex})$$

Where:

kWh <sub>Base</sub>	=	Energy consumption of existing equipment (kWh)
---------------------	---	--

**Appendix A – Technical Resource Manual****Ameren Missouri**

T	=	Cooling load at given part load condition (tons)
OH	=	Annual operating hours at given part load condition (hr)
$\eta_{Ex}$	=	Efficiency of existing chiller at given part load condition (kW/ton)

**Measure Life:** 20 years with proper maintenance.

**Retrofit Electricity Demand and Energy Consumption:** The existing operating profile is the basis for the retrofit consumption. Since the installation of the chiller will not affect the building load or operating hours, these parameters are identical to the existing analysis. The identical equations are used above with the insertion of the retrofit efficiency.

$$kWh_{Ret} = T(OH)(\eta_{Ret})$$

Where:

$kWh_{Ret}$	=	Retrofit energy consumption (kWh)
T	=	Capacity of chiller (tons)
OH	=	Equivalent full load annual operating hours (hr)
$\eta_{Ret}$	=	Full load efficiency for retrofit chiller (kW/ton)

Or:

$$kWh_{Ret} = \sum T(OH)(\eta_{Ret})$$

Where:

$kWh_{Ret}$	=	Retrofit energy consumption (kWh)
T	=	Cooling load at given part load condition (tons)
OH	=	Annual operating hours at given part load condition (hr)
$\eta_{Ret}$	=	Efficiency of retrofit chiller at given part load condition (kW/ton)

The electricity demand and energy savings are calculated as follows.

$$kW_{Saved} = kW_{base} - kW_{Ret}$$

$$kWh_{Saved} = kWh_{base} - kWh_{Ret}$$

**Chiller Replacement**

This measure involves the replacement of an existing chiller with a more efficient chiller. The following equation applies.

$$kW_{Saved} = (\eta_{Ext} - \eta_{Ret})(T)$$

The kWh energy savings have been estimated based on an assumed annual load factor of 55%.

$$kWh_{Saved} = (\eta_{Saved})(T)(LF)(Hr)$$

**Free Cooling**

Weather data is used to identify the annual hours in which outdoor air conditions are sufficient to provide water at a desirable temperature. Typically, demand savings may not be present with this measure because the process systems require water temperatures around 55-65°F and a cooling tower cannot meet these temperatures during the peak period. However, in many industrial facilities, air compressors are currently being cooled by chilled water. This equipment can be cooled with as high as 90°F water.

$$kWh_{Save} = (Tons) \left( \frac{kW}{Ton} \right)_{Chill} (Hr)_{Free}$$

**Chilled Water Pipe Insulation**

The industry standard 3E+ insulation software<sup>3</sup> can be used as the basis. This program calculates the heat loss in bare and insulated pipes and is identified by the DOE Industrial Technologies Program as an assessment tool for insulation.

$$kW_{Saved} = (HL_{3E+})(\eta_{Chill})$$

$$kWh_{Saved} = (kW_{Saved})(Hr)$$

### Install VSD on Chiller

The installation of a VSD on a chiller will improve the efficiency of the chiller especially at part loads. The methodology is very similar to the chiller retrofit. We assume that there is some excess capacity in the chiller system during peak periods and demand savings will be realized.

$$kW_{Saved} = (\eta_{Exist} - \eta_{VSD})(T_{Peak})$$

Energy savings have been estimated with a load bin analysis with a typical load profile.

$$kWh_{Saved} = \Sigma(kW_{Saved})(Hr)$$

### Cooling Tower Replacement

This measure involves the complete replacement of the cooling tower. Savings are based on an improvement in heat exchanging efficiency and an improvement of the chiller efficiency with a lower condenser water temperature.

$$kW_{Saved} = (\eta_{Exist} - \eta_{Prop})(T_{Peak})$$

$$kWh_{Saved} = (kW_{Saved})(Hr)$$

### Controls and EMS

**Energy Savings Methodologies:** In determining the energy savings associated with a Building Automation System (BAS) or EMS, one must first determine the level of automation. Typically, the BAS controls HVAC systems from a demand perspective (ON/OFF) as well as an energy perspective. The following formulas are representative of the implementation of typical sequences of operation:

Savings = Motor Savings + Heating Savings + Cooling Savings

Motor Savings = Motor Cost<sub>base</sub> – Motor Cost<sub>prop</sub>

For constant volume fans:

$$Motor\ Energy_{base} = \sum_{motor} \frac{motor\ hp \times load\ factor \times 0.746\ kW / bhp \times motor\ op\ hrs_{base}}{\eta_{motor}}$$

$$Motor\ Energy_{prop} = \sum_{motor} \frac{motor\ hp \times load\ factor \times 0.746\ kW / bhp \times motor\ op\ hrs_{prop}}{\eta_{motor}}$$

For VAV fans:

$Motor\ Energy_{base}$

$$= \sum_{motor} \left( \frac{motor\ hp \times load\ factor \times 0.746\ kW / bhp}{\eta} \right) \times (\% \text{ load})^{factor_{base}} \times motor\ op\ hrs_i$$

$Motor\ Energy_{prop}$

$$= \sum_{motor} \left( \frac{motor\ hp \times load\ factor \times 0.746\ kW / bhp}{\eta} \right) \times (\% \text{ load})^{factor_{prop}} \times motor\ op\ hrs_i$$

$$Heat\ Load_{base} = \sum \frac{(1.08 \times mixed\ cfm_{base} \times (temp_{MA_{base}} - temp_{DA_{base}})) \times bin\ hrs_{base}}{\eta_{heating} \times 10^6\ Btu / MMBtu}$$

$$Heat\ Load_{prop} = \sum \frac{(1.08 \times mixed\ cfm_{prop} \times (temp_{MA_{prop}} - temp_{DA_{prop}})) \times bin\ hrs_{prop}}{\eta_{heating} \times 10^6\ Btu / MMBtu}$$

Cooling Savings = Cool Cost<sub>base</sub> + Cool Cost<sub>prop</sub>

Cool Cost = Cool Load<sub>elec</sub> (kWh/year) × Elec Util Rate (\$/kWh)

$$Cool\ Load_{elec\ base} = \sum \frac{(4.5 \times mixed\ cfm_{base} \times (H_{DA_{base}} - H_{MA_{base}})) \times bin\ hrs_{base} \times \eta_{cooling\ elec}}{12,000\ Btu / ton - hr}$$

$$Cool\ Load_{elec\ prop} = \sum \frac{(4.5 \times mixed\ cfm_{prop} \times (H_{DA_{prop}} - H_{MA_{prop}})) \times bin\ hrs_{prop} \times \eta_{cooling\ elec}}{12,000\ Btu / ton - hr}$$

$$mixed\ cfm_{base / prop} = vent\ air\ cfm_{base / prop} + return\ air\ cfm_{base / prop}$$

Where:

Motor hp	=	Horsepower of motor
$\eta_{motor}$	=	Efficiency of motor from manufacturer published data and verified during the pre-installation inspection
% load	=	Ratio of the flow in the current bin to the full load capability of the fan or pump
$factor_{base/prop}$	=	Affinity law relationship between flow and power for the pump or fan
$vent\ cfm_{base}$	=	Existing ventilation cfm
$vent\ cfm_{prop}$	=	Proposed ventilation cfm (reduced for some AHUs)
$temp_{DA}$	=	Discharge air temperature
$temp_{MA}$	=	Temperature of mixed air in temperature bin
$H_{DA}$	=	Discharge air enthalpy
$H_{MA}$	=	Enthalpy of mixed air in temperature bin
$\eta_{heating}$	=	Efficiency of heating equipment
$\eta_{cooling}$	=	Efficiency of cooling equipment, kW/ton for electric cooling

### Compressed Air

**End Use Description:** This measure involves a modification of the compressed air system at the facility. Typical measures include installing more efficient equipment, reducing the operating pressure, and/or reducing facility plant air needs.

The end-use can be broken into the two separate systems, supply-side and demand-side. The supply side typically consists of an air compressor, air dryer (for moisture sensitive products and lines), and a storage tank. The three basic types of compressors are rotary screw, reciprocating, and centrifugal.

Additionally, the type of control can vary. These include: 1) inlet modulation with unloading; 2) inlet modulation without unloading; 3) load/unload; and 4) on/off. The higher the output pressure, the more work is required by the compressor to deliver the required flow (scfm) to the facility. Thus, the operating pressure will affect the energy consumption of the system. All these factors will result in a different overall efficiency (kW/scfm).

Also, examination of the uses for compressed air could lead to measures to reduce compressed air consumption. Some of these include, using blowers rather than compressed air when high pressure air is not necessary, replacing nozzles, using pressure sensors rather than timed intervals to only purge when necessary, and using water mists to cool hot products rather than compressed air.

**Energy Efficiency Measures:** There are many potential measures associated with the air compressor end-use. However, the measure can be broken down into four distinct categories. These include:

- **Air Compressor Replacement:** A minimum efficiency baseline adjustment may apply depending on the efficiency of the existing equipment.
- **Air Compressor Controls:** This applies to multiple compressor systems and will optimize the operation of the system to operate the most efficient compressor at a given time.
- **Air Compressor Pressure Reduction:** A general rule of thumb is that energy consumption is reduced 1% for every 2 psig of pressure reduction. However, a larger storage-tank volume may be needed to effectively reduce the compressor discharge pressure.
- **Reduction of Air Demand:** Several methods may be used to reduce the air demand of the plant. One of these is the replacement of existing nozzles with nozzles that require less air (such as venturi nozzles), and also to resize the nozzles for the specific application. Another is to use a blower for low pressure applications rather than high pressure compressed air. If air pressure regulators do not exist in the plant, the installation of individual machine pressure regulators will reduce the air demand for the system. And, finally, a leak management program should always be instituted and maintained. ~~Although the amount of air leakage is always identified when the compressed air system is analyzed, this measure is not eligible for incentives and savings from these measures are not proposed in this program.~~

**Baseline Calculation:** The power demand of an air compressor is dependent on the air requirements at the facility. The requirements can fluctuate drastically throughout the day. Thus, the facility's air profile is typically estimated through short-term monitoring of the true RMS kW of the air compressors at the facility. The preferred method is to calculate the annual power demand and energy consumption is with the DOE AirMaster+ software. These programs require an hourly demand profile in power (kW) or flow (scfm). Alternatively, the consumption can be calculated with the manufacturer's specifications and engineering equations.

Industry standard efficiencies exist for typical compressor and control types. Baseline adjustments only apply to air compressor retrofits when the equipment is replaced. Since other components within the compressed air system are modified when the operating compressor size is reduced, baseline adjustments do not apply.

The baseline AirMaster+ model is used as a basis for the retrofit power demand (kW) and energy (kWh) consumption. The load profile will be modified based on the amount of air reduced through energy

efficiency efforts. Parameters such as orifice diameter, pressure and volumetric flow can be used to calculate the reduction in air.

**Retrofit Calculations:** For measures that will install equipment to replace the compressor (e.g., replacing with a blower), the power demand of the blower will be accounted for with the following equation:

$$kW_B = 0.746 \left( \frac{HP}{\eta} \right) (LF)$$

Where:

$kW_B$	=	Power demand of retrofit blower motor (kW)
hp	=	Horsepower rating of the retrofit blower motor from nameplate
$\eta$	=	Efficiency of retrofit blower motor
LF	=	Load factor (ratio of actual shaft hp vs. rated hp)
0.746	=	Conversion factor (hp to kW)

$$kWh_B = kW_B (OH)$$

Where:

$kWh_B$	=	Annual energy consumption of the retrofit blower (kWh)
OH	=	Annual operating hours of the blower (hr)

**Demand Reduction:** The demand on the air compressors is permanently reduced and is not weather dependent. Thus, power demand (kW) savings will be achieved. The total demand saved would be determined by the subtracting the demand of any auxiliary equipment added as part of the retrofit from the electricity demand saved by the air compressors. The air compressor demands are based on engineering calculations or outputs from the AirMaster+ modeling software.

**Energy Savings:** Energy savings are the Baseline energy consumption minus the Retrofit consumption. The net energy savings results from subtracting the consumption of the auxiliary equipment installed from the energy consumption outputs from the AirMaster+ model.

**Load Shape:** Trended data is used to establish the load shape. This is input into AirMaster+ model or an equivalent calculation methodology and is used as a basis for the retrofit power demand (kW) and energy (kWh) consumption. The load profile will be modified based on the amount of air reduced through energy efficiency efforts. Manufacturer specifications can be used in the case of the replacement of nozzles or demand side equipment.

**Measure Cost:** The measure cost will include the cost of the installation of the demand reducing equipment and any other modifications that may be required to the system to ensure the process is not affected with the retrofit.

#### Compressed Air Pressure Reduction

This measure involves the installation of equipment to allow for the reduction in the discharge. This equipment could be additional storage for the compressed air system or equipment within the system to reduce the overall pressure drop. The rule of thumb is that for every two psi reduction the energy consumption is reduced by 1%.

$$kW_{Saved} \cong (kW_{Exist}) \left( \frac{1\%}{2 \text{ psi}} \right) (P)$$



The demand reduction will occur at all times the system operates. Thus, the kWh energy savings are:

$$kWh_{Saved} = (kW_{Saved})(Hr)$$

### Compressed Air System Controls

This measure involves the installation of controls to optimize the operation air compressors in systems with multiple machines. These control systems have the ability to trend data and continue to monitor the demand to ensure that the most efficient compressor is being utilized at any one time. Additionally, the system will help to manage correct system pressure automatically. The existing compressor system must be monitored for a representative period of time and analyzed to completely understand the air demand on the system. Each distinct period of existing operation ( $\Sigma kW_{Exist-i}$ ) is analyzed to determine the optimum operating sequence ( $\Sigma kW_{Post-i}$ ).

$$kW_{Saved} = \Sigma kW_{Exist-i} - \Sigma kW_{Post-i}$$

$$kW_{Saved} = \Sigma [(kW_{Exist-i})(Hr_i)] - \Sigma [(kW_{Post-i})(Hr_i)]$$

### Air Compressor Replacement

This measure involves the replacement of an existing air compressor with a more efficient model. In many instances, the retrofit model will be controlled with a variable speed drive. As we expect the air compressor package power (kW/100 cfm) to vary as a function of load, a complete understanding of the system air profile is necessary to estimate the energy savings potential. Since the air compressor's energy consumption is typically not driven by outdoor air temperature, a weighted average of hours at each specific air demand can be used to estimate the expected peak kW reduction.

$$kW_{Saved} = \frac{\Sigma [(PP_{Exist-i} - PP_{Ret-i})(CFM_i)(Hr_i)]}{Hr_{Total}}$$

$$kWh_{Save} = \Sigma [(PP_{Exist-i} - PP_{Ret-i})(CFM_i)(Hr_i)]$$

### Compressed Air Demand Side Retrofit

Several methods may be used to reduce the air demand of the plant. One of these is the replacement of nozzles that require less air, such as venturi nozzles, and also to resize the nozzles for the specific application. Another is to use a blower for low pressure applications rather than high pressure compressed air. If regulators do not exist in the plant, the installation of individual machine pressure regulators will reduce the air demand for the system. And, finally, a leak management program should always be instituted and maintained. ~~Although the amount of air leakage is always identified when the compressed air system is analyzed, this measure is not eligible for incentives and savings have not been proposed with this program.~~

The average reduction in air use ( $CFM_{Red}$ ) through the installation of equipment is a permanent reduction in energy use. The estimated energy savings relates to the expected air profile after the installation. A complete understanding of the system air profile is necessary to estimate the energy savings potential.

$$kW_{Saved} = \Sigma (PP_{Exist-i})(CFM_{Exist}) - (PP_{Ret-i})(CFM_{Exist} - CFM_{Red})$$

$$kWh_{Save} = \Sigma [(PP_{Exist-i} - PP_{Ret-i})(CFM_i)(Hr_i)]$$

**VSD - Centrifugal Pumps**

The measure involves installing a VSD on a centrifugal pump. This measure slows the speed of the pump motor to only supply the necessary fluid to meet the demand of the system. The energy consumption of the system is reduced when the flow of the system is reduced.

**Baseline Power Demand and Energy Consumption:** The baseline power demand (kW) is typically constant during operation. This value would be determined with standard engineering equations or a spot measurement. In the case of the calculated approach, the general engineering equation is:

$$kW_{Base} = 0.746 \left( \frac{HP}{\eta} \right) (LF)$$

Where:

$kW_{Base}$	=	Demand of existing motor
hp	=	Horsepower rating of the existing motor from nameplate
$\eta$	=	Efficiency of existing motor or NEMA efficiency if motor is replaced
LF	=	Load factor (ratio of actual shaft hp vs. rated hp)
0.746	=	Conversion factor (hp to kW)

This demand is then multiplied by the annual operating hours (OH) of the motor to estimate the baseline annual energy consumption (kWh). The operating hours may be determined through short-term, run-time monitoring, examination of historical records, or interviews with facility personnel.

$$kWh_{Base} = kW_{Base} (OH)$$

**Baseline Adjustments:** In general, baseline adjustments do not apply with this measure. There are instances when the Customer may replace the existing motor with a Premium Efficiency motor at the same time the VSD is installed. In the event that the existing motor's efficiency is less than the National Electrical Manufacturers Association (NEMA) standard, the baseline will be adjusted to reflect the NEMA Standard Efficiency.

**Retrofit Power Demand and Energy Consumption:** The VSD will control the speed of the motor to match the desired flow profile of the system. A centrifugal pump follows the affinity laws relating the flow directly proportional to the speed and power and speed by the theoretical cube root. However, in practice, inefficiencies exist and this relationship is typically 2.5.

$$kW_2 = kW_1 \left( \frac{n_2}{n_1} \right)^{2.5}$$

Where:

$kW_1$	=	Known energy demand (kW), typically at 100% speed or flow
$kW_2$	=	Energy demand (kW) at different speed, $n_2$
$n_1$	=	Speed at condition 1, expressed as a percent
$n_2$	=	Speed at condition 2, expressed as a percent

VSD's exhibit energy and power losses of approximately 2% in larger motors and 5% in smaller motors. Therefore, the VSD controlled 100% flow is typically, less efficient than the baseline condition. Any operation in this region will result in negative savings.

The operating load profile in the retrofit system will vary depending on the application. A pump is almost always weather dependent if it is used for space conditioning. However, a process pump profile may be based on the production rate at the facility. The determination of an accurate assessment for the retrofit operating profile is critical to the retrofit consumption. This activity may include a load analysis, examination of historical weather data, data logging, and/or interviews with facility personnel. The retrofit energy consumption follows as the sum of the energy consumptions in each flow region.

**Demand and Energy Savings:** Demand savings result when the power (kW) of the system is reduced during the summer peak period. Demand savings will be present in many VSD pumping applications. The system is investigated to estimate the highest possible retrofit demand during the peak period. This value is subtracted from the baseline kW to estimate the demand savings. Demand savings typically do not exist for space conditioning applications. The energy savings are calculated by subtracting the retrofit consumption from the baseline.

### VSD – Ventilation Fan

The measure involves installing a VSD on a ventilation fan. This measure slows the speed of the fan motor to only supply the necessary air flow to meet the demand of the system. The energy consumption of the system is reduced when the flow of the system is reduced.

**Baseline Power Demand and Energy Consumption:** If there is not a mechanism, such as guide vanes or dampers, to restrict the fan flow, the baseline kW demand will be constant for this measure. This value would be determined with standard engineering equations or a spot measurement. In the case of the calculated approach, the general engineering equation is:

$$kW_{Base} = 0.746 \left( \frac{HP}{\eta} \right) (LF)$$

Where:

$kW_{Base}$	=	Demand of existing motor
hp	=	Horsepower rating of the existing motor from nameplate
$\eta$	=	Efficiency of existing motor or NEMA efficiency if motor is replaced
LF	=	Load factor (ratio of actual shaft hp vs. rated hp)
0.746	=	Conversion factor (hp to kW)

This demand is then multiplied by the annual operating hours (OH) of the motor to estimate the baseline energy consumption (kWh). The operating hours may be determined through short-term, run-time monitoring, examination of historical records, or interviews with facility personnel.

$$kWh_{Base} = kW_{Base} (OH)$$

If guide vanes or dampers exist to restrict the flow, the demand at different flow regions will vary. In this case, ASHRAE fan curves will be used to determine the demand in each flow region. The operating profile of the fan is critical to achieving an accurate assessment of the baseline consumption. A ventilation fan is almost always weather dependent if it is used for space conditioning. However, a process oriented fan profile may be based on the production rate of the facility. This activity may include a load analysis, examination of historical weather data, data logging, and/or interviews with facility personnel.

**Baseline Adjustments:** In general, baseline adjustments do not apply with this measure. There are instances when the Customer may replace the existing motor with a Premium Efficiency motor at the same time the VSD is installed. In the event that the existing motor's efficiency is less than the NEMA standard, the baseline will be adjusted to reflect the NEMA Standard Efficiency.

**Retrofit Power Demand and Energy Consumption:** The VSD will control the speed of the motor to match the desired air flow requirements of the ventilation system. A centrifugal fan follows the affinity laws relating the flow directly proportional to the speed and power and speed by the theoretical cube root. However, in practice, inefficiencies exist and this relationship is typically 2.5.

$$kW_2 = kW_1 \left( \frac{n_2}{n_1} \right)^{2.5}$$

Where:

$kW_1$	=	Known energy demand (kW), typically at 100% speed or flow
$kW_2$	=	Energy demand (kW) at different speed, $n_2$
$n_1$	=	Speed at condition 1, expressed as a percent
$n_2$	=	Speed at condition 2, expressed as a percent

VSD's exhibit energy and power losses of approximately 2% in larger motors, and 5% in smaller ones. Therefore, the VSD controlled 100% flow is typically, less efficient than the baseline condition. Any operation in this region will result in negative savings.

If a mechanism to restrict the air flow did not exist in the baseline case, the operating hours flow profile will be determined in the same manner as described above. If a mechanism was present, the retrofit profile is typically identical to the baseline.

The retrofit energy consumption follows as the sum of the energy consumptions in each flow region.

**Demand and Energy Savings:** Demand savings result when the power (kW) of the system is reduced during the summer peak period. Demand savings will be present in many VSD ventilation applications. The system is investigated to estimate the highest possible retrofit demand during the peak period. This value is subtracted from the baseline kW to estimate the demand savings. Demand savings typically do not exist for space conditioning applications.

The energy savings is calculated by subtracting the retrofit consumption from the baseline.

### Generic Process Upgrades

The majority of the energy consumption and energy efficiency opportunities in industrial facilities exist within the actual production process. This end use consists of specific equipment used in the production lines at a facility and are varied depending on the applications ranging from production equipment to heat rejection equipment such as cooling towers.

**Energy Efficiency Measures:** There are countless measures associated with this end use depending on the specific process and facility involved. This section discusses generic process improvements that apply to a large number of industrial facilities.

**Facility Process Improvement:** A facility process improvement involves a measure that reduces the overall production efficiency (kWh/unit produced). This will account for a retrofit that will allow for an increase in production with the same or increased energy use, but results in a net reduction in kWh/unit

production. In this instance, the difference in the overall plant or system production efficiency determines the energy savings.

**Process Cooling Tower Upgrade:** This energy efficiency measure involves upgrading the existing inefficient cooling towers with energy efficient systems that have improved heat transfer enhancement.

**Hydraulic Process Improvement:** A retrofit to a hydraulic pump and motor system can reduce energy consumption during the clamp period of the cycle.

#### Facility Process Improvement

This measure will pay incentives for the installation of new, high-efficiency equipment to meet the expanded process needs of an existing facility or to accommodate new production loads. Projects that involve modifying an existing operation, structure or process due to growth or expansion will also be included under this measure.

In general, the calculation methodology is the same for the specific process improvements. The calculation involves the difference in production efficiency (kW/unit, kWh/unit). The incentives for retrofit measures with increased capacity will be based on the post-installation production. In general, the following equations apply:

$$kW_{Saved} = \left[ \left( \frac{kW_{Exist}}{Unit_{Exist}} \right) - \left( \frac{kW_{Ret}}{Unit_{Ret}} \right) \right] (Unit_{Ret})$$

$$kWh_{Saved} = \left[ \left( \frac{kWh_{Exist}}{Unit_{Exist}} \right) - \left( \frac{kWh_{Ret}}{Unit_{Ret}} \right) \right] (Unit_{Ret})$$

#### Process Cooling Tower Upgrade

This measure involves the upgrades of the cooling tower used to cool equipment in the process or the product. Savings are based on an improvement in heat exchanging efficiency and an improvement of the chiller efficiency, if applicable, with a lower condenser water temperature.

$$kW_{Saved} = (\eta_{Exist} - \eta_{Prop}) (T_{Peak})$$

$$kWh_{Saved} = (kW_{Saved}) (Hr)$$

#### Hydraulic Process Improvement

A hydraulic system uses significant energy to maintain pressure throughout the entire cycle. Additionally, the hydraulic fluid must be cooled. Often times, this is done by mechanical cooling. A retrofit to a hydraulic pump and motor system can reduce the energy consumption during specific periods of the cycle. This specifically occurs during the clamp period of the cycle. A torque controlled servo motor can maintain the pressure of the fluid during clamp and hold periods at almost no power consumption. The speed of the shaft is constantly monitored to maintain the pressure in the system. Additionally, the requirement for hydraulic fluid cooling is eliminated. Monitoring of the system must be performed to completely understand the cycle and when the system can save energy.

$$kW_{Saved} = kW_{Ave-Exist-Cycle} - kW_{Ave-Ret-Cycle}$$

$$kWh_{Saved} = \sum kW_{Saved-period-i} (Hr_{period-i})$$

#### All Other

New and/or emerging technologies, as well as non-evaluated measures, will be evaluated by Program Engineers using commonly accepted engineering practices. These evaluations will be subject to review and approval by Ameren Missouri prior to issuance of a custom incentive offer. Following project completion the measure may be subject to EM&V review to confirm the results of the project.

Upon determination that the measure should be evaluated for inclusion in the TRM, the process as outlined in the section entitled "Protocol for Deeming Measures Not Found Within TRM" shall be employed and the measure treated accordingly.

## Building Simulation Protocols<sup>10</sup>

### Introduction

This report presents the results of an engineering study of common residential and commercial buildings retrofit measures analyzed in support of creating a statewide retrofit measure savings database for Ameren Business and Corporate Services. These per unit energy savings estimates will be used to guide program design and cost effectiveness calculations for Ameren Business and Corporate Services energy efficiency programs. The measures and analysis techniques are described in the following sections and are applicable to those measures within this TRM being derived from the Morgan Measure Database (MMD).

A set of residential and commercial prototypical building models was developed using the DOE-2.2 building energy simulation program for each of the market segments defined. The prototypes are based on the models used in the California Database for Energy Efficiency Resources (DEER) study, with appropriate modifications to adapt these models to local design practices and climate.

For the residential sector, prototype models for single family detached, multifamily and manufactured homes were developed. Prototype models for small commercial buildings were developed for small retail, big-box retail, small office, fast food restaurant, full service restaurant, school, assembly, warehouse, grocery and light industrial buildings. Large commercial building prototypes for large office, hospital, and hotel building types were also developed.

The HVAC measures for residential buildings include split system central air conditioners, air source heat pumps and dual fuel heat pumps, condensing gas furnaces with and without EC motors, and ground source heat pumps. Setback thermostats, duct insulation and leakage sealing, and refrigerant charge correction measures were also analyzed. Shell measures include roof, wall, floor, crawlspace and basement insulation upgrades, high-performance glazing, and air leakage sealing. Whole house fans and efficient ceiling fans were also analyzed.

The HVAC measures for small commercial buildings include single package rooftop air conditioners and heat pumps, split system air conditioners and heat pumps, packaged terminal air conditioners and heat pumps, and water loop heat pumps. Setback thermostats, air side economizers, and refrigerant charge correction measures were also analyzed. HVAC measures for large commercial buildings include air cooled and water cooled chillers, chilled water setback control, and variable frequency drives on fans and pumps. Shell measures include window films, high-performance glazing, and cool roofs. Refrigeration

<sup>10</sup> Developed for Ameren Missouri by Architectural Energy Corporation on behalf of Morgan Marketing Partners. September 2009.

measures include anti-sweat heater controls, case night covers, floating head pressure control and high-efficiency condensers.

Energy savings estimates were developed from the prototype models. The results of these simulations were compiled into a database containing measure savings and measure costs by building type and climate zone. The database was delivered in an Excel spreadsheet format. Population weights for climate zone, building type and vintage can be applied to compile weighted savings across all building types, vintages and climate zones of interest to the IOUs.

**Residential Building Prototype Model Development**

Residential sector models of single family detached “stick-built” and manufactured homes along the two sizes of multifamily homes were developed. The description of the single family, manufactured home and multifamily prototypes follows.

**Single Family Homes**

Residential sector models of single family detached “stick-built” and manufactured homes were developed. The description of the single family and manufacture home prototypes follows.

This analysis is based on DOE-2.2 simulations of a set of prototypical single family residential buildings. The prototypical simulation models were derived from the residential building prototypes used in the California DEER study, with adjustments made for local building practices and climate. The prototype “model” in fact contains 4 separate residential buildings; 2 one-story and 2 two-story buildings. Each version of the 1 story and 2 story buildings are identical except for the orientation, which is shifted by 90 degrees. The selection of these 4 buildings is designed to give a reasonable average response of buildings of different design and orientation to the impact of energy efficiency measures.

Three separate models were created to represent general vintages of buildings:

- Old, poorly insulated building constructed in the 1950s or earlier. This vintage is referred to as the “old” vintage
- Existing, average insulated building conforming to 1980s era building codes. This vintage is referred to as the “average” vintage.
- New construction conforming to the IECC 2004. This vintage is referred to as the “new” vintage.



A sketch of the residential prototype buildings is shown in Figure 1.

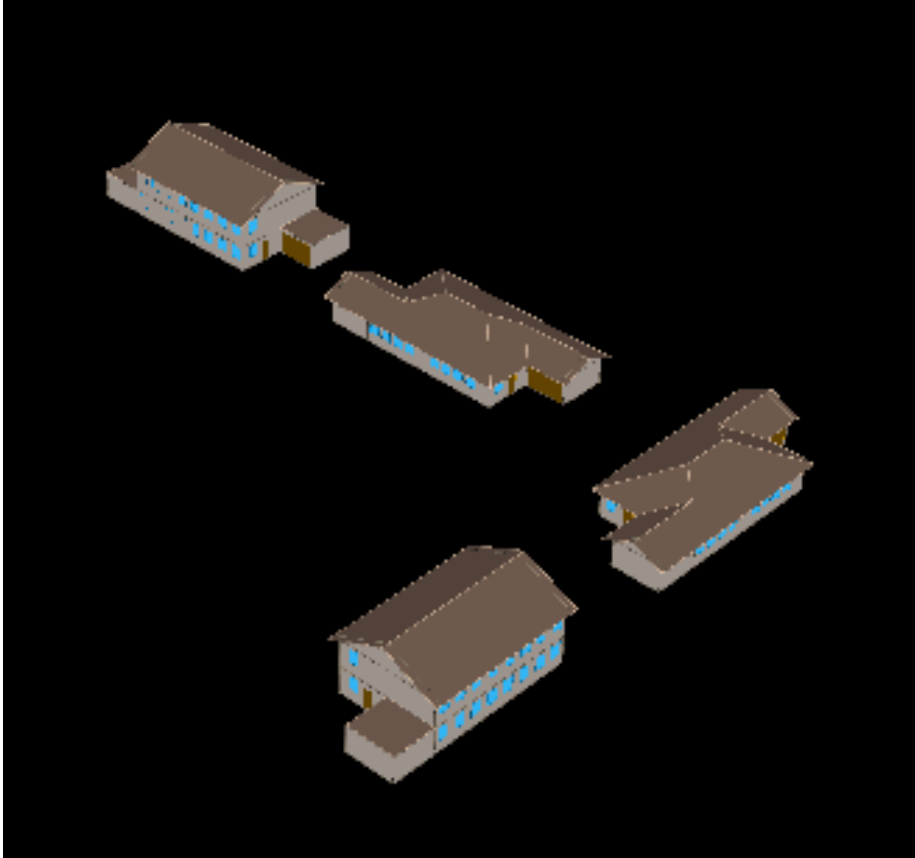

**Figure 1. Computer rendering of residential building prototypical DOE-2 model.**  
The base prototype includes an unconditioned basement. The general characteristics of the residential building prototype model are summarized in Table 1.

**Table 1. Residential Building Prototype Description**

Characteristic	Value
Vintage	Three vintages simulated – old poorly insulated buildings, existing average insulated buildings and new buildings
Conditioned floor area	1 story house: 1465 SF (not including basement) 2 story house: 2930 SF (not including basement)
Wall construction and R-value	Wood frame with siding, R-value varies by vintage
Roof construction and R-value	Wood frame with asphalt shingles, R-value varies by vintage
Glazing type	Average of single and double pane; properties vary by vintage
Lighting and appliance power density	0.51 W/SF average

**Appendix A – Technical Resource Manual****Ameren Missouri**

Characteristic	Value
HVAC system type	Central split system AC with gas furnace Central split system heat pump Electric furnace only Gas furnace only
HVAC system size	Based on ASHRAE design day peak load with 20% oversizing.
HVAC system efficiency	Baseline SEER = 13
Thermostat setpoints	Heating: 70°F with setback to 60°F Cooling: 75°F with setup to 80°F
Duct location	Buildings without basement: attic Buildings with basement: basement
Duct surface area	Single story house: 390 SF supply, 72 SF return Two story house: 505 SF supply, 290 SF return
Duct insulation	Uninsulated
Duct leakage	20% of fan flow total leakage, evenly split between supply and return.
Natural ventilation	Allowed during cooling season when cooling setpoint exceeded and outdoor temperature < 65°F. 2 air changes per hour

**Wall, Floor and Ceiling Insulation Levels**

The assumed insulation R-values for wall, floor and ceiling insulation by vintage are shown in Table 2 through Table 4.

**Table 2. Wall Insulation R-Value Assumptions by Vintage**

Vintage	Assumed R-value of insulated wall	Notes
Older, poorly insulated	7	Wood frame 2x4 with wood siding, drywall, no insulation
Existing, average insulation	11	Fiberglass insulation in 2 by 4 wall per MEC 1980
New construction	St Louis - 15	IECC 2004

**Table 3. Floor Insulation Levels by Vintage**

Vintage	Assumed R-value of insulated wall	Notes
Older, poorly insulated	2	12" concrete block, no insulation
Existing, average insulation	6	12" concrete block, 1" expanded polystyrene
New construction	St Louis - 21	IECC 2004

**Table 4. Ceiling Insulation R-Value Assumptions by Vintage**

Vintage	Assumed R-value of insulated ceiling	Notes
Older, poorly insulated	11	Minimal ceiling insulation
Existing, average insulation	19	Fiberglass insulation per MEC 1980
New construction	St Louis - 38	IECC 2004

**Windows**

The glazing U-value and solar heat gain coefficient (SHGC) assumptions for the three vintages are shown in Table 5.

**Table 5. Window Property Assumptions by Vintage**

Vintage	U-value (Btu/hr-F-SF)	SHGC	Notes
Older, poorly insulated	0.93	0.87	Single pane clear
Existing, average insulation	0.68	0.77	Avg. of Double Pane 1/2" air space (U=0.49) and standard double pane (U=0.87)
New construction	0.35	St Louis – 0.40	IECC 2004

**Infiltration**

Infiltration rate assumptions were set by vintage as shown in Table 6.

**Table 6. Infiltration Rate Assumptions by Vintage**

Vintage	Assumed infiltration rate	Notes
Older, poorly insulated	1 ACH	
Existing, average insulation	0.5 ACH	
New construction	0.35 ACH	Minimum without forced ventilation per ASHRAE Standard 66.

**Manufactured Homes**

This analysis is based on DOE-2.2 simulations of a set of prototypical manufactured homes. The prototypical simulation models were derived from the manufactured home prototypes used in the California DEER study, with adjustments made for local building practices and climate. The prototype "model" in fact contains 2 separate buildings; each version is identical except for the orientation, which is shifted by 90 degrees. The selection of these 2 buildings is designed to give a reasonable average

response of buildings of different orientations to the impact of energy efficiency measures. A computer rendering of the manufactured home DOE-2 prototype model is shown in Figure 2.

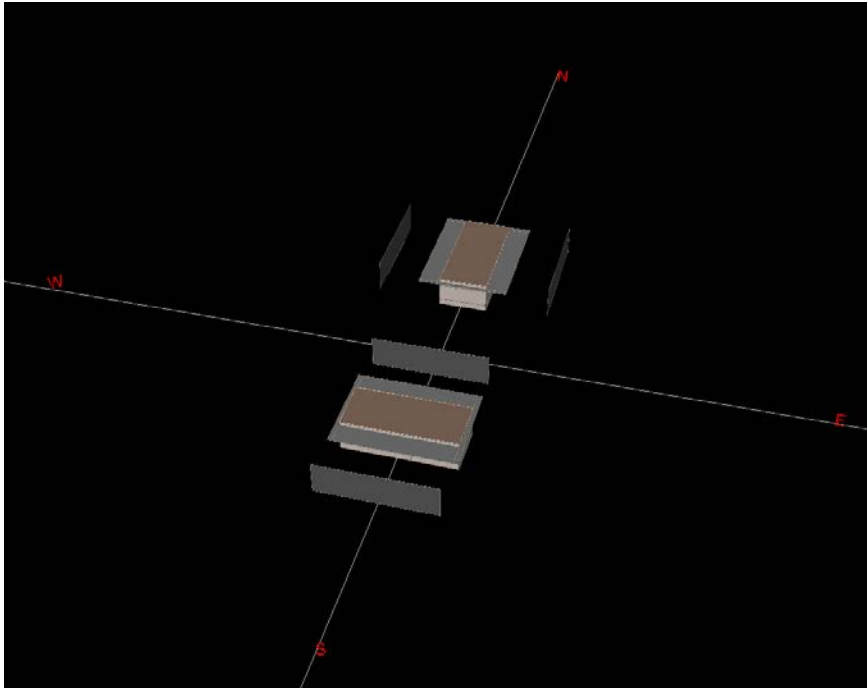

**Figure 2. Computer rendering of manufactured home prototypical DOE-2 model.**

Manufactured homes built before 1976 were constructed to much lower standards than those built later. Homes built prior to 1976 had only one or two inches of insulation wrapped around the walls, floor and ceiling, 2" x 2" or 2" x 3" studs, uninsulated air ducts, no ceiling vapor barrier, and jalousie windows. Manufactured homes manufactured in 1976 or later were built to much higher standards required by the HUD (US Government Dept. of Housing and Urban Development). An overall description of the manufactured home prototype model is shown in Table .

**Table 7. Manufactured Home Prototype Building Description**

Characteristic	Value
Vintage	Three vintages simulated – Pre 78, 78-95, and 95-05.
Conditioned floor area	1196 SF (23 x 52)
Wall construction and R-value	Wood frame, R-value varies by vintage
Roof construction and R-value	Wood frame, R-value varies by vintage
Glazing type	Single or double pane, varies by vintage. 191 SF (16% of floor area)
Lighting and appliance power density	0.58 W/SF

**Appendix A – Technical Resource Manual****Ameren Missouri**

Characteristic	Value
HVAC system types	Central split system AC with gas furnace Central split system AC with electric furnace Central split system heat pump Central dual fuel heat pump Electric furnace only Gas furnace only
HVAC system size	Based on ASHRAE design day peak load with 20% oversizing.
HVAC system efficiency	Baseline SEER = 13
Thermostat setpoints	Heating: 70°F with setback to 60°F Cooling: 75°F with setup to 80°F
Duct location	Attic
Duct surface area	360 SF (supply only)
Duct insulation	Uninsulated
Duct leakage	22.5% of fan flow total leakage, evenly split between supply and return.
Natural ventilation	Allowed during cooling season when cooling setpoint exceeded and outdoor temperature < 65°F. 2 air changes per hour

**Wall, Floor and Ceiling Insulation Levels**

The assumed values for wall and ceiling by vintage are shown in Table .

**Table 8. Wall Floor and Ceiling Insulation R-Value Assumptions by Vintage**

Vintage	R-value of insulated wall	R-value of insulated floor	R-value of insulated ceiling
Pre 78	5.0	5.0	5.0
78 - 94	8.0	8.0	8.0
95 - 05	13.0	13.0	13.0

**Windows**

The glazing U-value and solar heat gain coefficient (SHGC) assumptions for the three vintages are shown in Table .

**Table 9. Window Property Assumptions by Vintage**

Vintage	U-value (Btu/hr-F-SF)	SHGC
Pre 78	1.27	0.87
78 - 94	0.87	0.77
95 - 05	0.65	0.56

### Infiltration

Infiltration rate assumptions were set by vintage as shown in Table .

**Table 10. Infiltration Rate Assumptions by Vintage**

Vintage	Assumed infiltration rate
Pre 78	1 ACH
78 - 94	0.5 ACH
95 - 05	0.35 ACH

### Multifamily

Analysis used to develop parameters for the energy and demand savings calculations are based on DOE-2.2 simulations of a set of prototypical multifamily buildings. The prototypical simulation models were derived from the multifamily residential building prototypes used in the California DEER<sup>11</sup> study, with adjustments made for local building practices and climate.

Prototypes were developed for the multi-family 2-4 unit and the multi-family 5+ unit sections. The multifamily 2-4 unit building is a four unit building, with 2 units on each of 2 floors. The multi-family 5+ unit building is a 12 unit building, with 6 units on each of two floors.

The low-rise prototype “models” in fact contains 2 separate buildings. Each version of the building is identical except for the orientation, which is shifted by 90 degrees. The selection of these 2 orientations is designed to give a reasonable average response of buildings of different design and orientation to the impact of energy efficiency measures.

Three separate models were created to represent general vintages of buildings:

- Old: Poorly insulated building constructed in the 1950s or earlier. This vintage is referred to as the “old” vintage
- Existing: Average insulated building conforming to 1980s era building codes. This vintage is referred to as the “average” vintage.
- New: Construction conforming to the current state energy standards for residential buildings. This vintage is referred to as the “new” vintage.

Each building was run with up to 7 different HVAC system types to capture the range of HVAC systems common in low-rise multifamily buildings. A sketch of the low-rise 5+ unit prototype is shown in Figure 3 below.

<sup>11</sup> 2004-2005 Database for Energy Efficiency Resources (DEER) Update Study, Final Report, Itron, Inc. Vancouver, WA. December, 2005. Available at [http://www.calmac.org/publications/2004-05\\_DEER\\_Update\\_Final\\_Report-Wo.pdf](http://www.calmac.org/publications/2004-05_DEER_Update_Final_Report-Wo.pdf)

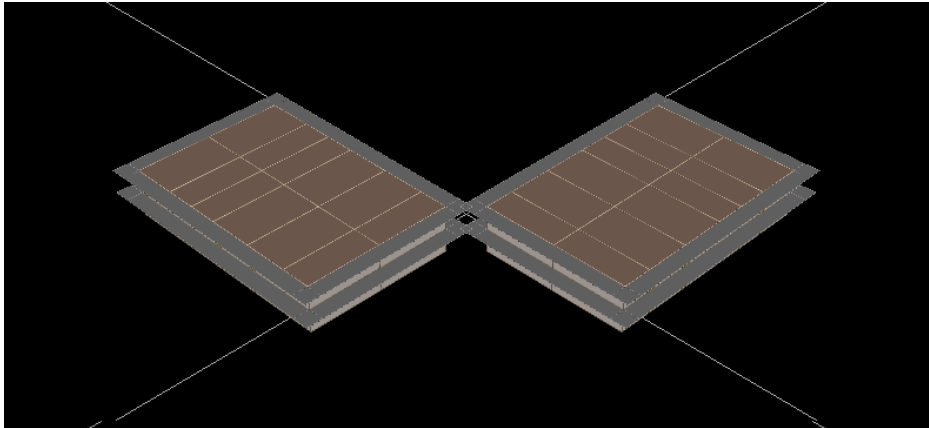

**Figure 3. Low-rise Multifamily 5+ Unit Building**

The general characteristics of the multi-family building prototype model are summarized in Table 12 below:

**Table 11. Multifamily Low-Rise Residential Building Prototype Description**

Characteristic	Value
Vintage	Three vintages simulated – old poorly insulated buildings, existing average insulated buildings and new buildings
Conditioned floor area	<b>2-4 unit building:</b> 950 SF per unit; 2 units per floor, 2 floors per building, 3,800 SF total <b>5+ unit building:</b> 950 SF per unit; 6 units per floor, 2 floors per building, 11,400 SF total.
Wall construction and R-value	Wood frame with siding, R-value varies by vintage
Roof construction and R-value	Wood frame with asphalt shingles, R-value varies by vintage
Glazing type	Single or double pane; properties vary by vintage
Lighting and appliance power density	0.87 W/SF average in bedrooms, 0.58 W/SF in living space
HVAC system types <sup>12</sup>	Split system AC with gas heat Split system AC with electric heat Split system heat pump PTAC with electric heat PTHP Electric heat only (no AC) Gas heat only (no AC)
HVAC system size	Based on peak load with 20% oversizing.
HVAC system efficiency	AC and heat pump: SEER = 13 PTAC and PTHP: EER = 7.1 (Old and Average) PTAC and PTHP: EER = 8.7 (New) Furnace AFUE = 78

<sup>12</sup> PTAC and PTHP systems simulated for MF 5+ unit building only.

**Appendix A – Technical Resource Manual****Ameren Missouri**

Characteristic	Value
Thermostat setpoints	Heating: 70°F with setback to 67°F Cooling: 75°F with setup to 78°F
Duct location	In attic and plenum space between first and second floors. PTACs and PTHPs have no duct work.
Duct surface area	256 SF supply, 47 SF return per system
Duct insulation	Uninsulated
Duct leakage	20% of fan flow total leakage, evenly split between supply and return.
Natural ventilation	Allowed during cooling season when cooling setpoint exceeded and outdoor temperature < 65°F. 3 air changes per hour

**Wall and Ceiling Insulation Levels**

The assumed values for wall and ceiling by vintage are shown in Tables 13-14 below:

**Table 12. Wall Insulation R-Value Assumptions by Vintage**

Vintage	Assumed R-value of insulated wall	Notes
Older, poorly insulated	7	No insulation in 2 by 4 wall; 3.5 in. air gap resistance only
Existing, average insulation	11	Fiberglass insulation in 2 by 4 wall per MEC 1980
New construction	Springfield – 19 St Louis - 15	Code

**Table 13. Ceiling Insulation R-Value Assumptions by Vintage**

Vintage	Assumed R-value of insulated ceiling	Notes
Older, poorly insulated	11	Minimal ceiling insulation
Existing, average insulation	19	Fiberglass insulation per MEC 1980
New construction	38	Code



## Appendix A – Technical Resource Manual

## Ameren Missouri

### Windows

The glazing U-value and solar heat gain coefficient (SHGC) assumptions for the three vintages are shown in Table 15 below.

**Table 14. Window Property Assumptions by Vintage**

Vintage	U-value (Btu/hr-F-SF)	SHGC	Notes
Older, poorly insulated	0.93	0.87	Single pane clear
Existing, average insulation	0.68	0.77	Double pane clear
New construction	0.35	Springfield – 0.55 St Louis – 0.40	Double low e per code

### Infiltration

Infiltration rate assumptions were set by vintage as shown in Table 16 below.

**Table 15. Infiltration Rate Assumptions by Vintage**

Vintage	Assumed infiltration rate	Notes
Older, poorly insulated	1 ACH	
Existing, average insulation	0.5 ACH	
New construction	0.35 ACH	Minimum without forced ventilation per ASHRAE Standard 66.

### Residential Measure Savings Analysis

The prototype models were simulated with a variety of efficiency measures to develop a series of savings estimates. Efficiency measures are discussed in the following sections.

#### Air-Conditioners and Heat Pumps

Air conditioning systems were simulated with a baseline SEER 13 air conditioner and with a series of high efficiency air conditioners ranging from SEER 14 to SEER 17. Heat pump systems were simulated with a baseline SEER 13 heat pump and with a series of high efficiency heat pumps ranging from SEER 14 to SEER 18. Standard heat pumps were simulated with electric resistance backup, while dual fuel heat pumps were simulated with a gas furnace backup.

The basic efficiency assumptions for each of the air conditioner and heat pump measures are shown in Table 17. These data were taken from an extensive study of residential air conditioners and heat pumps conducted for the California DEER update study.<sup>13</sup> Besides these basic efficiency parameters, an extensive set of performance curves were developed representing mean performance of production units in each SEER category. These performance curves describe unit efficiency as a function of outdoor

<sup>13</sup> Itron, 2005. "2004-2005 Database for Energy Efficiency Resources (DEER) Update Study, Final Report," Itron, Inc., J.J. Hirsch and Associates, Synergy Consulting, and Quantum Consulting. December, 2005. Available at <http://eega.cpuc.ca.gov/deer>

## Appendix A – Technical Resource Manual

## Ameren Missouri

temperature, part-load efficiency, fan power, and so on. These curves were also applied to air conditioner and heat pump measures in each SEER category. All air conditioners and heat pumps SEER 14 and higher were assumed to have electronically commutated motors (ECM) and thermostatic expansion valves (TXV).

**Table 16. Baseline and Measure Performance Assumptions for Split Air Conditioners and Heat pumps**

Type	Efficiency	Fan Motor Type	EER	Sensible Heat Ratio	Air flow (CFM/ton)	Heating COP
Air conditioner	SEER 13	Standard	11.09	0.75	376	
	SEER 14	ECM	11.99	0.81	409	
	SEER 15	ECM	12.72	0.81	409	
	SEER 16	ECM	11.61	0.81	409	
	SEER 17	ECM	12.28	0.8	422	
Air Source and Dual Fuel Heat Pump	SEER 13	Standard	11.07	0.725	337	3.28
	SEER 14	ECM	11.72	0.78	400	3.52
	SEER 15	ECM	12.32	0.78	400	3.74
	SEER 16	ECM	12.06	0.78	400	3.48
	SEER 17	ECM	12.52	0.81	430	3.26
	SEER 18	ECM	12.80	0.8	428	3.66

Efficiency assumptions for PTAC and PTHP systems vary by unit size and whether the unit is replacing an existing unit or is a new installation. Typical efficiency values were chosen for a 1.5 ton unit. The baseline and measure efficiencies are shown in Table 17 below:

**Table 17. Baseline and Measure Performance Assumptions for PTACs and PTHPs.**

Type	Vintage	Cooling EER base	Heating COP base	Cooling EER measure	Heating COP measure
PTAC	Existing	7.1		9.3	
	New	8.7		10.3	
PTHP	Existing	7.0	2.4	9.1	3.0
	New	8.5	2.7	10.9	3.4

### Wall Insulation

For single family residential buildings, the “old” vintage model insulation is upgraded to R-13 to fill 2x4 wall construction. The “average” vintage model insulation is upgraded to R-13 and added one inch of rigid foam insulation to the exterior (R-5). The “new” vintage model added rigid foam insulation to the exterior.

For manufactured homes, the Pre 78 vintage model has R-5 insulation in wall, upgraded to R-10. The 78-95 vintage model has R-8 insulation in the wall, upgraded to R-13. The 95-05 vintage model has R-13 insulation in the wall, added rigid foam insulation to the exterior (R-21)

***Roof Insulation***

For single family residential buildings, the “old” vintage model has R-11 insulation, upgraded to R-30. The “average” vintage model has R-19 insulation, upgraded to R-30. The “new” vintage model roof insulation was upgraded to R-50

For manufactured homes, the Pre 78 vintage model has R-5 insulation in the roof, upgraded to R-10. The 78-95 vintage model has R-8 insulation in the roof, upgraded to R-30. The 95-05 vintage model has R-13 insulation in the roof, upgraded to R-38.

***Floor Insulation***

Single family homes were modeled above a basement, thus floor insulation was not modeled. For manufactured homes, the Pre 78 vintage model has R-5 insulation in the floor, upgraded to R-10. The 78-95 vintage model has R-8 insulation in the floor, upgraded to R-19. The 95-05 vintage model has R-13 insulation in the floor, upgraded to R-25.

***Basement Wall Insulation***

For single family residential buildings, the “old” vintage model has R-2 insulation, upgraded to R-19. The “average” vintage model has R-6 insulation, upgraded to R-19. The “new” vintage model has R-15 insulation, upgraded to R-19.

For manufactured homes, the crawlspace walls are simply skirting with no insulation for any vintage. The modeled measure assumes insulation is placed on the skirting in place of insulating the floor. R-19 insulation is assumed for all eras.

***Replacement Windows***

Window upgrades for single family residential buildings are based on the Energy Star specifications, with a U-value of 0.35 and a SHGC of 0.40. Window upgrades for manufactured homes are based on a high performance system with a U-value of 0.41 and a SHGC of 0.35.

***Duct Insulation***

Duct insulation was increased from the uninsulated base to R-6. Insulation was assumed to be applied to both supply and return ductwork as applicable.

***Duct Leakage***

Total duct leakage (supply plus return) is reduced to 6% of the HVAC system air flow at system operating static pressure.

***HVAC Tune-up***

This measure was modeled by simulating degrading the full-load efficiency of an untreated system in the base case and returning the treated system to its rated efficiency. A series of parametric runs was done to simulate the effect of HVAC tune-ups representing a 5%, 10% and 15% improvement.

***Setback Thermostat***

Two levels of setback were evaluated. A “moderate” setback case and a “full” setback case. For the moderate case, the heating schedule was changed from 70 degrees F for all 24 hours of the day in the base to 65 degrees from 11 pm to 6 am using a setback thermostat. Cooling schedule was changed from 75 degrees F for all 24 hours of the day in the base to 78 degrees from 11 pm to 6 am with the setback thermostat.

## Appendix A – Technical Resource Manual

## Ameren Missouri

For the full setback case, the heating schedule was changed from 70 degrees F for all 24 hours of the day in the base to 60 degrees from 11 pm to 6 am using a setback thermostat. Cooling schedule was changed from 75 degrees F for all 24 hours of the day in the base to 82 degrees from 11 pm to 6 am with the setback thermostat.

Note: baseline operation of buildings receiving setback thermostats may include some occupant manual setback of room temperature setpoints. This occupant behavioral effect on the baseline energy use is not accounted for in the simulations.

### EC Motor

For all EC motor measures, fan control was set to 2 speed operation and the fan power was reduced by 60%. The control of the furnace fan (either cycling with a call for heating or cooling; or continuous operation) was kept constant in the baseline and the EC motor simulations. Note: some occupants may change their operation from “cycling” to continuous operation after upgrading their furnace and/or air conditioner. This occupant behavioral effect on the energy savings is not accounted for in the simulations.

### Infiltration Reduction

Two simulations were run for this measure, where the infiltration rate is reduced by 30% and by 50% relative to the baseline infiltration rate, which varies by vintage.

### Commercial Building Prototype Model Development

Commercial sector prototype building models were developed for a series of small commercial buildings with packaged rooftop HVAC systems, including assembly, big box retail, fast food restaurant, full service restaurant, grocery, light industrial, primary school, small office and small retail buildings. A large office prototype was also included to analyze measures associated with built-up HVAC systems. The following sections describe the prototypical simulation models used in this analysis.

### Assembly

A prototypical building energy simulation model for an assembly building was developed using the DOE-2.2 building energy simulation program. The characteristics of the prototype are summarized in Table 18.

**Table 18. Assembly Prototype Building Description**

Characteristic	Value
Vintage	Existing (1970s) vintage
Size	34,000 square feet Auditorium: 33,240 SF Office: 760 SF
Number of floors	1
Wall construction and R-value	Concrete block, R-5
Roof construction and R-value	Wood frame with built-up roof, R-12
Glazing type	Multipane Shading-coefficient = 0.84 U-value = 0.72
Lighting power density	Auditorium: 1.9 W/SF Office: 1.55 W/SF
Plug load density	Auditorium: 1.2 W/SF Office: 1.7 W/SF
Operating hours	Mon-Sun: 8am – 9pm

**Appendix A – Technical Resource Manual****Ameren Missouri**

Characteristic	Value
HVAC system type	Packaged single zone, no economizer
HVAC system size	Based on ASHRAE design day conditions, 10% oversizing assumed.
Thermostat setpoints	Occupied hours: 75 cooling, 70 heating Unoccupied hours: 80 cooling, 65 heating

A computer-generated sketch of the prototype is shown in Figure 3.

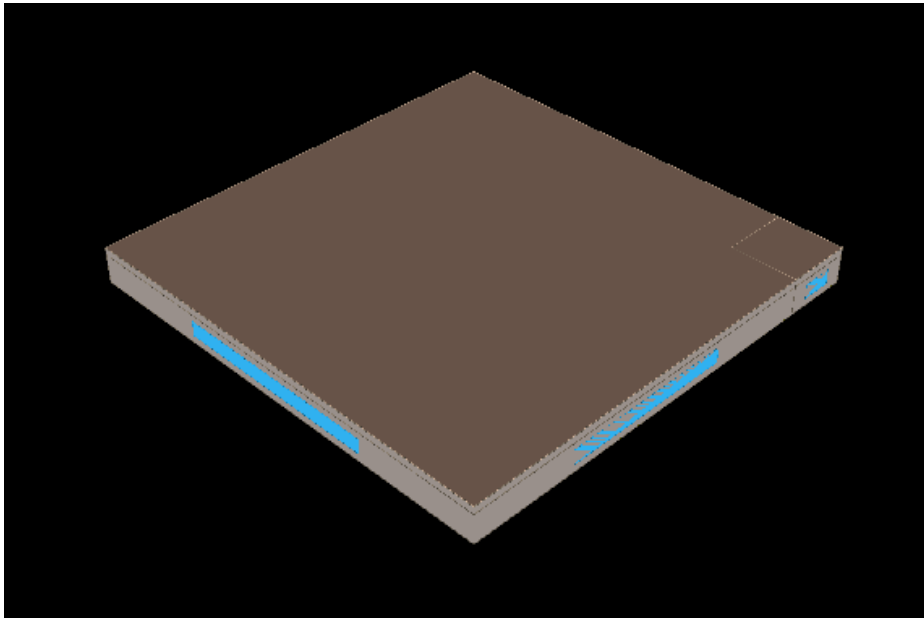

**Figure 3. Assembly Building Rendering**

### **Big Box Retail**

A prototypical building energy simulation model for a big box retail building was developed using the DOE-2.2 building energy simulation program. The characteristics of the prototype are summarized in Table 19.

**Table 19. Big Box Retail Prototype Building Description**

Characteristic	Value
Vintage	Existing (1970s) vintage
Size	130,500 square feet Sales: 107,339 SF Storage: 11,870 SF Office: 4,683 SF Auto repair: 5,151 SF Kitchen: 1,459 SF
Number of floors	1
Wall construction and R-value	Concrete block with insulation, R-7.5

**Appendix A – Technical Resource Manual****Ameren Missouri**

Characteristic	Value
Roof construction and R-value	Metal frame with built-up roof, R-13.5
Glazing type	Multipane; Shading-coefficient = 0.84 U-value = 0.72
Lighting power density	Sales: 2.15 W/SF Storage: 0.85 W/SF (Active) 0.45 W/SF (Inactive) Office: 1.55 W/SF Auto repair: 1.7 W/SF Kitchen: 2.2 W/SF
Plug load density	Sales: 1.15 W/SF Storage: 0.23 W/SF Office: 1.73 W/SF Auto repair: 1.15 W/SF Kitchen: 3.23 W/SF
Operating hours	Mon-Sun: 10am – 9pm
HVAC system type	Packaged single zone, no economizer
HVAC system size	Based on ASHRAE design day conditions, 10% oversizing assumed.
Thermostat setpoints	Occupied hours: 75 cooling, 70 heating Unoccupied hours: 80 cooling, 65 heating

A computer-generated sketch of the prototype is shown in Figure 4.

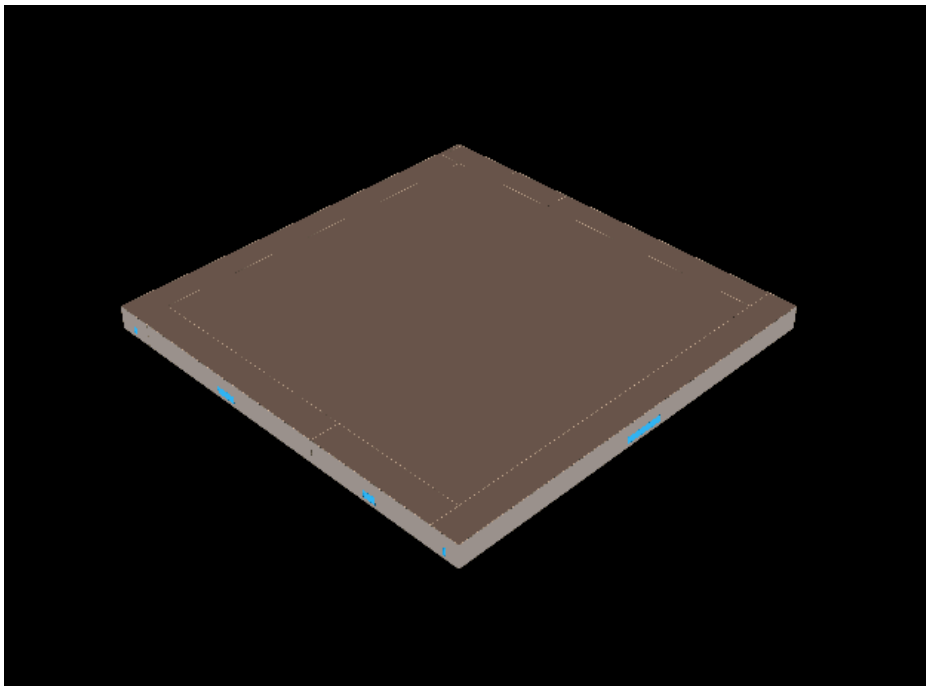

**Figure 4. Big Box Retail Building Rendering****Fast Food Restaurant**

A prototypical building energy simulation model for a fast food restaurant was developed using the DOE-2.2 building energy simulation program. The characteristics of the prototype are summarized in Table 20.

**Table 20. Fast Food Restaurant Prototype Building Description**

Characteristic	Value
Vintage	Existing (1970s) vintage
Size	2000 square feet 1000 SF dining 600 SF entry/lobby 300 SF kitchen 100 SF restroom
Number of floors	1
Wall construction and R-value	Concrete block with brick veneer, R-7.5
Roof construction and R-value	Concrete deck with built-up roof, R-13.5
Glazing type	Multipane Shading-coefficient = 0.84 U-value = 0.72
Lighting power density	Dining: 1.7 W/SF Entry area: 1.7 W/SF Kitchen: 2.2 W/SF Restroom: 0.9 W/SF
Plug load density	0.6 W/SF dining 0.6 W/SF entry/lobby 4.3 W/SF kitchen 0.2 W/SF restroom
Operating hours	Mon-Sun: 6am – 11pm
HVAC system type	Packaged single zone, no economizer
HVAC system size	Based on ASHRAE design day conditions, 10% oversizing assumed.
Thermostat setpoints	Occupied hours: 75 cooling, 70 heating Unoccupied hours: 80 cooling, 65 heating

A computer-generated sketch of the prototype is shown in Figure 5.

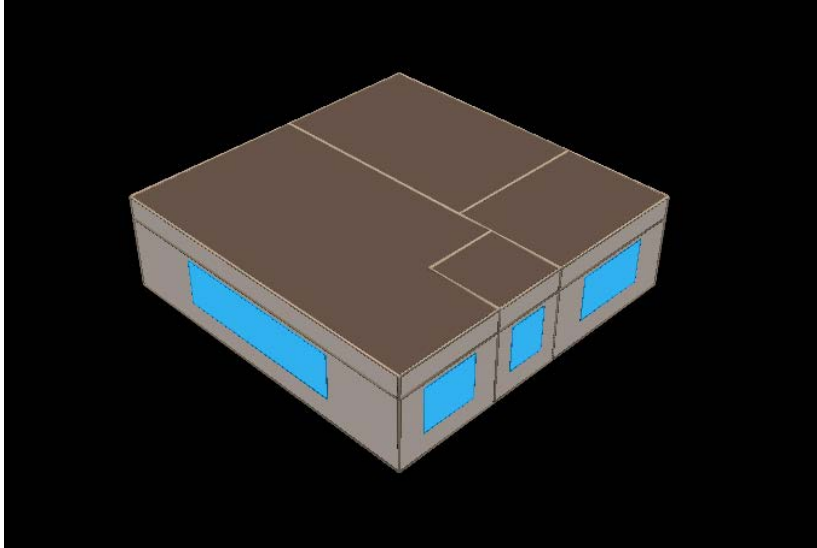

**Figure 5. Fast Food Restaurant Building Rendering**

### **Full-Service Restaurant**

A prototypical building energy simulation model for a full-service restaurant was developed using the DOE-2.2 building energy simulation program. The characteristics of the full service restaurant prototype are summarized in Table 21.

**Table 21. Full Service Restaurant Prototype Description**

Characteristic	Value
Vintage	Existing (1970s) vintage
Size	2000 square foot dining area 600 square foot entry/reception area 1200 square foot kitchen 200 square foot restrooms
Number of floors	1
Wall construction and R-value	Concrete block with brick veneer, R-7.5
Roof construction and R-value	Wood frame with built-up roof, R-13.5
Glazing type	Multipane; Shading-coefficient = 0.84 U-value = 0.72
Lighting power density	Dining area: 1.7 W/SF Entry area: 1.7 W/SF Kitchen: 2.2 W/SF Restrooms: 1.5 W/SF
Plug load density	Dining area: 0.6 W/SF Entry area: 0.6 W/SF Kitchen: 3.1 W/SF Restrooms: 0.2 W/SF



**Appendix A – Technical Resource Manual****Ameren Missouri**

Characteristic	Value
Operating hours	9am – 12am
HVAC system type	Packaged single zone, no economizer
HVAC system size	Based on ASHRAE design day conditions, 10% oversizing assumed.
Thermostat setpoints	Occupied hours: 75 cooling, 70 heating Unoccupied hours: 80 cooling, 65 heating

A computer-generated sketch of the full-service restaurant prototype is shown in Figure 6.

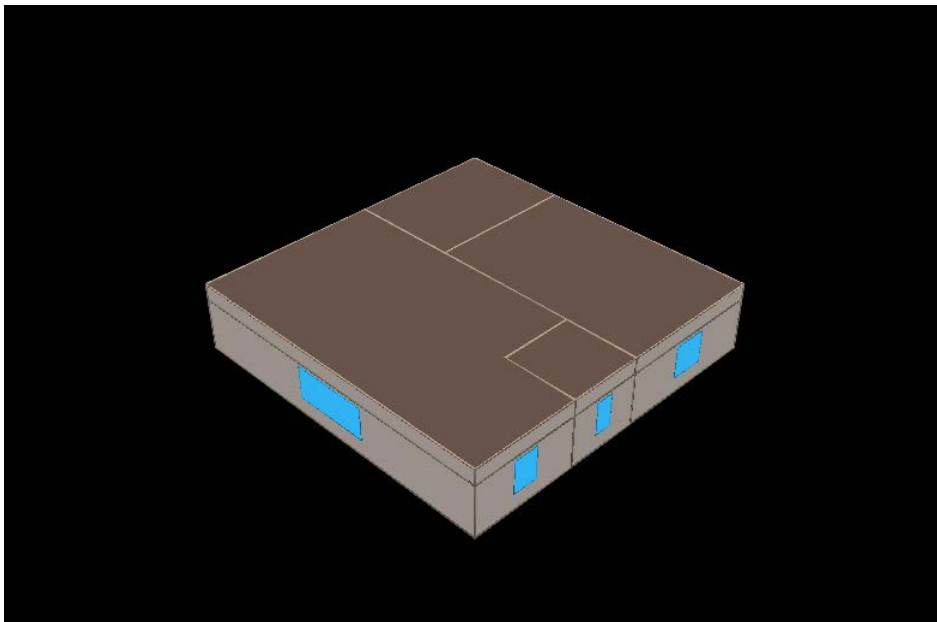

**Figure 6. Full Service Restaurant Prototype Rendering**

### Grocery

A prototypical building energy simulation model for a grocery building was developed using the DOE-2.2 building energy simulation program. The characteristics of the prototype are summarized in Table 22.

**Table 22. Grocery Prototype Building Description**

Characteristic	Value
Vintage	Existing (1970s) vintage
Size	50,000 square feet Sales: 40,000 SF Office and employee lounge: 3,500 SF Dry storage: 2,860 SF 50 °F prep area: 1,268 SF 35 °F walk-in cooler: 1,560 SF

**Appendix A – Technical Resource Manual****Ameren Missouri**

Characteristic	Value
	- 5 °F walk-in freezer: 812 SF
Number of floors	1
Wall construction and R-value	Concrete block with insulation, R-5
Roof construction and R-value	Metal frame with built-up roof, R-12
Glazing type	Single pane clear
Lighting power density	Sales: 3.36 W/SF Office: 2.2 W/SF Storage: 1.82 W/SF 50°F prep area: 4.3 W/SF 35°F walk-in cooler: 0.9 W/SF - 5°F walk-in freezer: 0.9 W/SF
Equipment power density	Sales: 1.15 W/SF Office: 1.73 W/SF Storage: 0.23 W/SF 50°F prep area: 0.23 W/SF + 36 kBtu/hr process load 35°F walk-in cooler: 0.23 W/SF + 17 kBtu/hr process load - 5°F walk-in freezer: 0.23 W/SF+ 29 kBtu/hr process load
Operating hours	Mon-Sun: 6am – 10pm
HVAC system type	Packaged single zone, no economizer
Refrigeration system type	Air cooled multiplex
Refrigeration system size	Low temperature (-20°F suction temp): 23 compressor ton Medium temperature (18°F suction temp): 45 compressor ton
Refrigeration condenser size	Low temperature: 535 kBtu/hr THR Medium temperature: 756 kBtu/hr THR
Thermostat setpoints	Occupied hours: 74°F cooling, 70°F heating Unoccupied hours: 79°F cooling, 65°F heating

A computer-generated sketch of the prototype is shown in Figure 7.

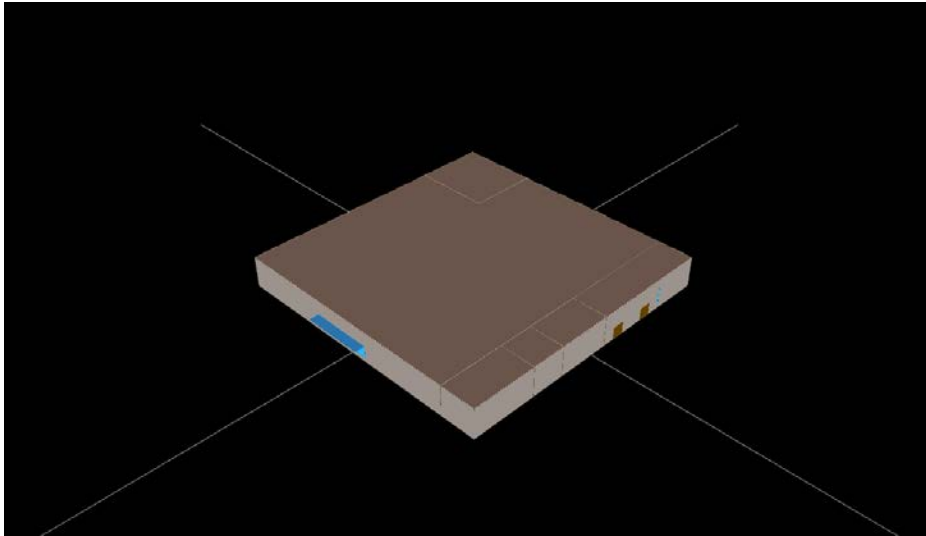

Figure 7. Grocery Building Rendering

**HOSPITAL**

A prototypical building energy simulation model for a large hospital building was developed using the DOE-2.2 building energy simulation program. The characteristics of the prototype are summarized in Table 23.

**Table 23. Large Hospital Prototype Building Description**

Characteristic	Value
Vintage	Existing (1970s) vintage
Size	250,000 square feet
Number of floors	3
Wall construction and R-value	Brick and CMU, R=7.5
Roof construction and R-value	Built-up roof, R-13.5
Glazing type	Multipane; Shading-coefficient = 0.84 U-value = 0.72
Lighting power density	Patient rooms: 2.3 W/SF Office: 2.2 W/SF Lab: 4.4 Dining: 1.7 Kitchen and food prep: 4.3
Plug load density	Patient rooms: 1.7 W/SF Office: 1.7 W/SF Lab: 1.7 Dining: 0.6 Kitchen and food prep: 4.6
Operating hours	24/7, 365
HVAC system types	Patient Rooms: 4 pipe fan coil

**Appendix A – Technical Resource Manual****Ameren Missouri**

Characteristic	Value
	Kitchen: Rooftop DX Remaining space; 1. Central constant volume system with hydronic reheat, without economizer; 2. Central constant volume system with hydronic reheat, with economizer; 3. Central VAV system with hydronic reheat, with economizer
HVAC system size	Based on ASHRAE design day conditions, 10% oversizing assumed.
Chiller type	Water cooled and air cooled
Chilled water system type	Constant volume with 3 way control valves,
Chilled water system control	Constant CHW Temp, 45 deg F setpoint
Boiler type	Hot water, 80% efficiency
Hot water system type	Constant volume with 3 way control valves,
Hot water system control	Constant HW Temp, 180 deg F setpoint
Thermostat setpoints	Occupied hours: 76 cooling, 72 heating Unoccupied hours: 81 cooling, 67 heating

Each set of measures was run using each of three different HVAC system configurations – a constant volume reheat system without economizer, a constant volume reheat system with economizer and a VAV system with economizer. The constant volume reheat system without economizer represents system with the most heating and cooling operating hours, while the VAV system with economizer represents a system with the least heating and cooling hours. This presents a range of system loads and energy savings for each measure analyzed.

A computer-generated sketch of the prototype is shown in Figure 15

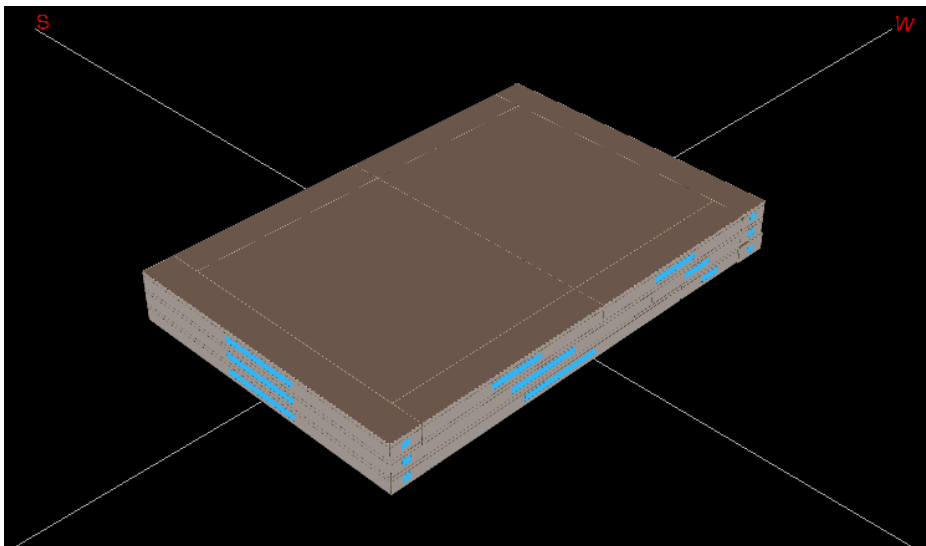

**Figure 15. Hospital Building Rendering****Hotel**

A prototypical building energy simulation model for a Hotel building was developed using the DOE-2.2 building energy simulation program. The characteristics of the prototype are summarized in Table 24.

**Table 24. Hotel Prototype Building Description**

Characteristic	Value
Vintage	Existing (1970s) vintage
Size	200,000 square feet total Bar, cocktail lounge – 800 SF Corridor – 20,100 SF Dining Area – 1,250 SF Guest rooms – 160,680 SF Kitchen – 750 SF Laundry – 4,100 SF Lobby – 8,220 Office – 4,100 SF
Number of floors	11
Wall construction and R-value	Block construction, R-7.5
Roof construction and R-value	Wood deck with built-up roof, R-13.5
Glazing type	Multipane; Shading-coefficient = 0.84 U-value = 0.72
Lighting power density	Bar, cocktail lounge – 1.7 W/SF Corridor – 1.0 W/SF Dining Area – 1.7 W/SF Guest rooms – 0.6 W/SF Kitchen – 4.3 W/SF Laundry – 1.8 W/SF Lobby – 3.1 W/SF Office – 2.2 W/SF
Plug load density	Bar, cocktail lounge – 1.2 W/SF Corridor – 0.2 W/SF Dining Area – 0.6 W/SF Guest rooms – 0.6 W/SF Kitchen – 3.0 W/SF Laundry – 3.5 W/SF Lobby – 0.6 W/SF Office – 1.7 W/SF
Operating hours	Rooms: 60% occupied 40% unoccupied All others: 24 hr / day
HVAC system type	Central built-up system: All except corridors and rooms 1. Central constant volume system with perimeter hydronic reheat, without economizer; 2. Central constant volume system with perimeter hydronic reheat, with economizer;

## Appendix A – Technical Resource Manual

## Ameren Missouri

Characteristic	Value
	3. Central VAV system with perimeter hydronic reheat, with economizer PTAC : Guest rooms PSZ: Corridors
HVAC system size	Based on ASHRAE design day conditions, 10% oversized assumed.
Chiller type	Water cooled and air cooled
Chilled water system type	Constant volume with 3 way control valves,
Chilled water system control	Constant CHW Temp, 45 deg F setpoint
Boiler type	Hot water, 80% efficiency
Hot water system type	Constant volume with 3 way control valves,
Hot water system control	Constant HW Temp, 180 deg F setpoint
Thermostat setpoints	Occupied hours: 76 cooling, 72 heating Unoccupied hours: 81 cooling, 67 heating

A computer-generated sketch of the prototype is shown in Figure 17. Note, the middle floors, since they thermally equivalent, are simulated as a single floor, and the results are multiplied by 9 to represent the energy consumption of the 9 middle floors.

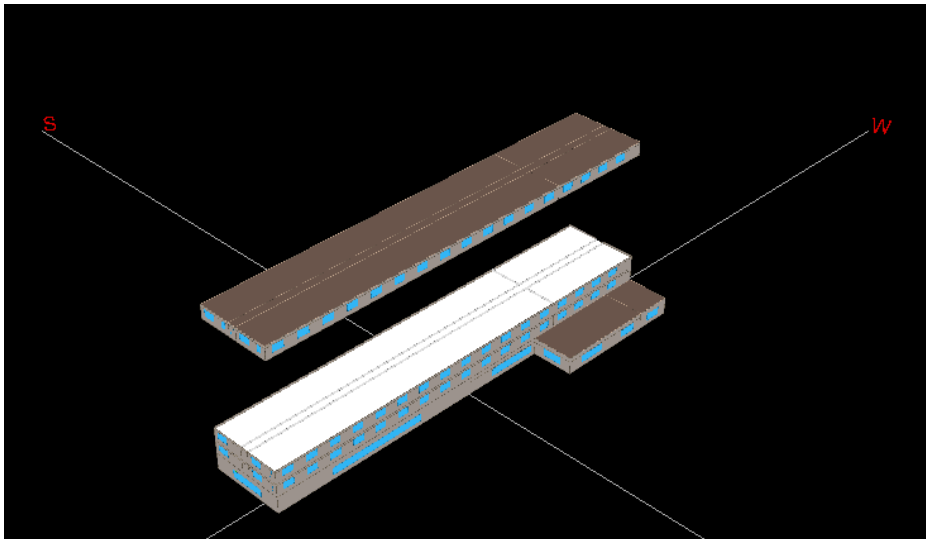

Figure 17. Hotel Building Rendering

**Large Office**

A prototypical building energy simulation model for a large office building was developed using the DOE-2.2 building energy simulation program. The characteristics of the prototype are summarized in

Table

~~Table~~-25.

**Table 25. Large Office Prototype Building Description**

Characteristic	Value
Vintage	Existing (1970s) vintage
Size	350,000 square feet
Number of floors	10
Wall construction and R-value	Glass curtain wall, R-7.5
Roof construction and R-value	Built-up roof, R-13.5
Glazing type	Multipane; Shading-coefficient = 0.84 U-value = 0.72
Lighting power density	Perimeter offices: 1.55 W/SF Core offices: 1.45 W/SF
Plug load density	Perimeter offices: 1.6 W/SF Core offices: 0.7 W/SF
Operating hours	Mon-Sat: 9am – 6pm Sun: Unoccupied
HVAC system types	1. Central constant volume system with perimeter hydronic reheat, without economizer; 2. Central constant volume system with perimeter hydronic reheat, with economizer; 3. Central VAV system with perimeter hydronic reheat, with economizer
HVAC system size	Based on ASHRAE design day conditions, 10% oversizing assumed.
Chiller type	Water cooled and air cooled
Chilled water system type	Constant volume with 3 way control valves,
Chilled water system control	Constant CHW Temp, 45 deg F setpoint
Boiler type	Hot water, 80% efficiency
Hot water system type	Constant volume with 3 way control valves,
Hot water system control	Constant HW Temp, 180 deg F setpoint
Thermostat setpoints	Occupied hours: 75 cooling, 70 heating Unoccupied hours: 80 cooling, 65 heating

Each set of measures was run using each of three different HVAC system configurations – a constant volume reheat system without economizer, a constant volume reheat system with economizer and a VAV system with economizer. The constant volume reheat system without economizer represents system with the most heating and cooling operating hours, while the VAV system with economizer represents a system with the least heating and cooling hours. This presents a range of system loads and energy savings for each measure analyzed.

A computer-generated sketch of the prototype is shown in Figure 8. Note, the middle floors, since they thermally equivalent, are simulated as a single floor, and the results are multiplied by 8 to represent the energy consumption of the 8 middle floors.

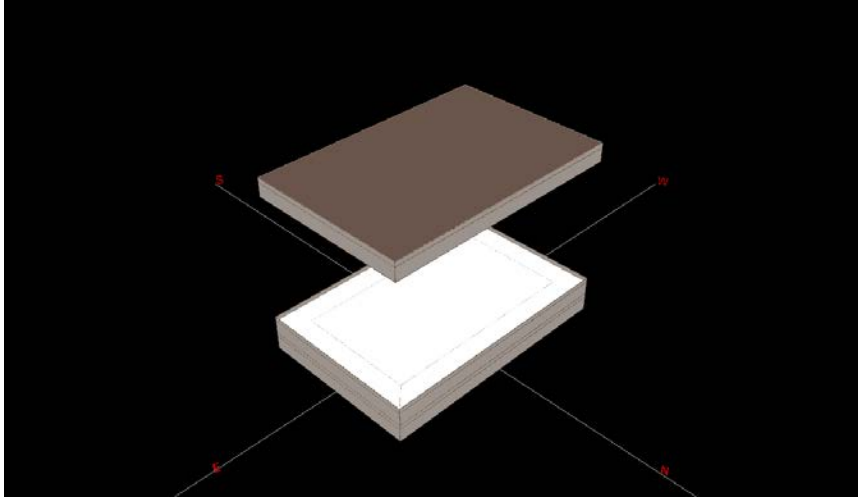

Figure 8. Large Office Building Rendering

### Light Industrial

A prototypical building energy simulation model for a light industrial building was developed using the DOE-2.2 building energy simulation program. The characteristics of the prototype are summarized in Table 26.

Table 26. Light Industrial Prototype Building Description

Characteristic	Value
Vintage	Existing (1970s) vintage
Size	100,000 square feet total 80,000 SF factory 20,000 SF warehouse
Number of floors	1
Wall construction and R-value	Concrete block with Brick, no insulation, R-5
Roof construction and R-value	Concrete deck with built-up roof, R-12
Glazing type	Multipane; Shading-coefficient = 0.84 U-value = 0.72
Lighting power density	Factory – 2.25 W/SF Warehouse – 0.7 W/SF
Plug load density	Factory – 1.2 W/SF Warehouse – 0.2 W/SF
Operating hours	Mon-Fri: 6am – 6pm Sat Sun: Unoccupied
HVAC system type	Packaged single zone, no economizer
HVAC system size	Based on ASHRAE design day conditions, 10%



**Appendix A – Technical Resource Manual****Ameren Missouri**

Characteristic	Value
	oversizing assumed.
Thermostat setpoints	Occupied hours: 75 cooling, 70 heating Unoccupied hours: 80 cooling, 65 heating

A computer-generated sketch of the prototype is shown in Figure 9.

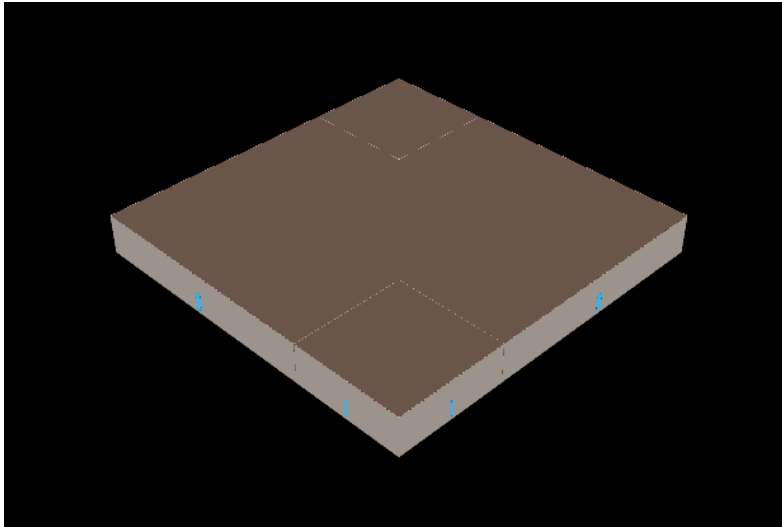

**Figure 9. Light Industrial Building Rendering**

### **Primary School**

A prototypical building energy simulation model for an elementary school was developed using the DOE-2.2 building energy simulation program. The model is really of two identical buildings oriented in two different directions. The characteristics of the prototype are summarized in Table 27.

**Table 27. Elementary School Prototype Building Description**

Characteristic	Value
Vintage	Existing (1970s) vintage
Size	2 buildings, 25,000 square feet each; oriented 90° from each other Classroom: 15,750 SF Cafeteria: 3,750 SF Gymnasium: 3,750 SF Kitchen: 1,750 SF
Number of floors	1
Wall construction and R-value	Concrete with brick veneer, R-7.5
Roof construction and R-value	Wood frame with built-up roof, R-13.5
Glazing type	Multipane Shading-coefficient = 0.84 U-value = 0.72
Lighting power density	Classroom: 1.8 W/SF Cafeteria: 1.3 W/SF

**Appendix A – Technical Resource Manual****Ameren Missouri**

Characteristic	Value
	Gymnasium: 1.7 W/SF Kitchen: 2.2 W/SF
Plug load density	Classroom: 1.2 W/SF Cafeteria: 0.6 W/SF Gymnasium: 0.6 W/SF Kitchen: 4.2 W/SF
Operating hours	Mon-Fri: 8am – 6pm Sun: 8am – 4pm
HVAC system type	Packaged single zone, no economizer
HVAC system size	Based on ASHRAE design day conditions, 10% oversizing assumed.
Thermostat setpoints	Occupied hours: 75 cooling, 70 heating Unoccupied hours: 80 cooling, 65 heating

A computer-generated sketch of the prototype is shown in Figure 10.

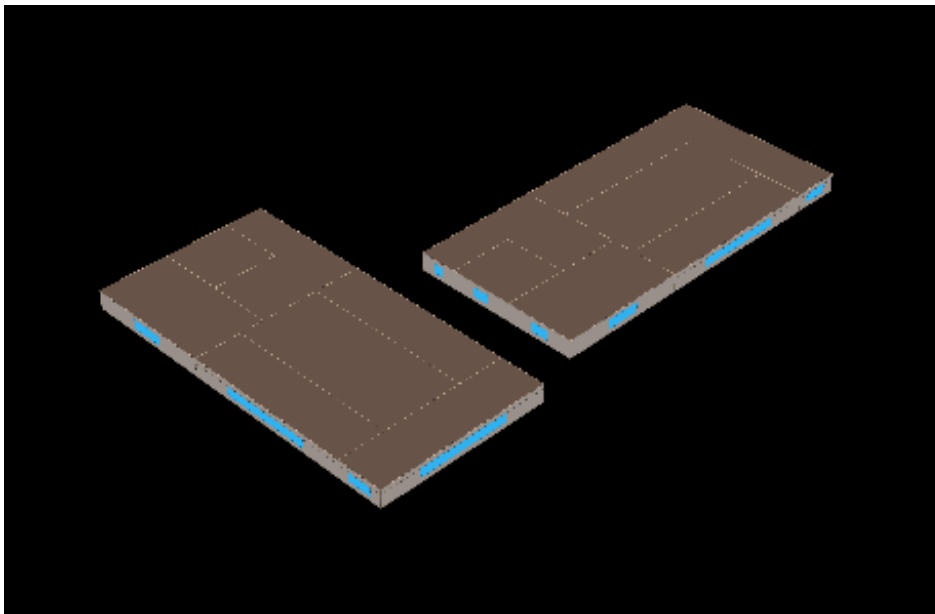

**Figure 10. School Building Rendering**

### **Small Office**

A prototypical building energy simulation model for a small office was developed using the DOE-2.2 building energy simulation program. The characteristics of the small office prototype are summarized in Table 28.

**Table 28. Small Office Prototype Building Description**

Characteristic	Value
Vintage	Existing (1970s) vintage
Size	10,000 square feet
Number of floors	2
Wall construction and R-value	Wood frame with brick veneer, R-7.5
Roof construction and R-value	Wood frame with built-up roof, R-13.5
Glazing type	Multipane; Shading-coefficient = 0.84 U-value = 0.72
Lighting power density	Perimeter offices: 1.55 W/SF Core offices: 1.45 W/SF
Plug load density	Perimeter offices: 1.6 W/SF Core offices: 0.7 W/SF
Operating hours	Mon-Sat: 9am – 6pm Sun: Unoccupied
HVAC system type	Packaged single zone, no economizer
HVAC system size	Based on ASHRAE design day conditions, 10% oversizing assumed.
Thermostat setpoints	Occupied hours: 75 cooling, 70 heating Unoccupied hours: 80 cooling, 65 heating

A computer-generated sketch of the small office prototype is shown in Figure 11.

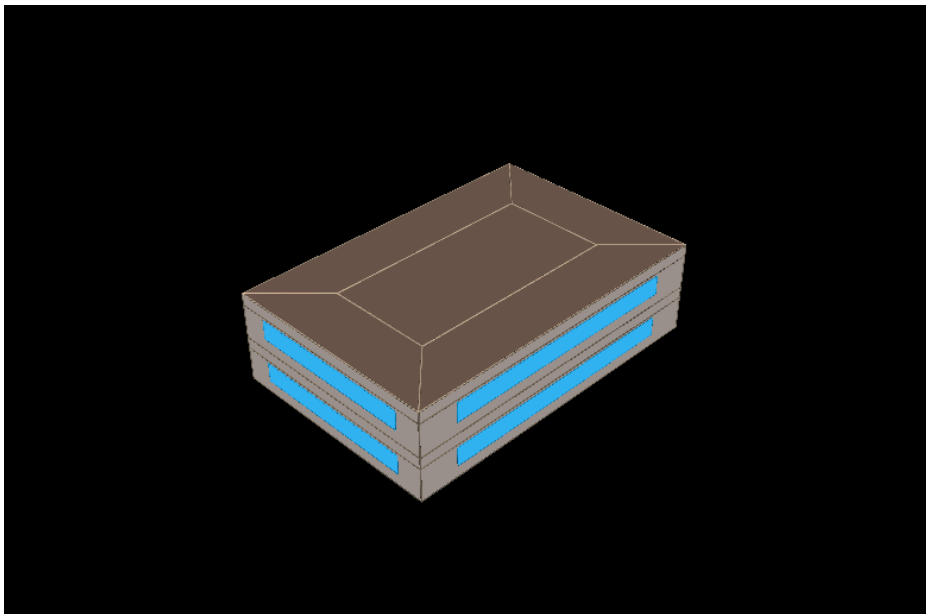

**Figure 11. Small Office Prototype Building Rendering**

**Small Retail**

A prototypical building energy simulation model for a small retail building was developed using the DOE-2.2 building energy simulation program. The characteristics of the small retail building prototype are summarized in Table 29.

**Table 29. Small Retail Prototype Description**

Characteristic	Value
Vintage	Existing (1970s) vintage
Size	6400 square foot sales area 1600 square foot storage area 8000 square feet total
Number of floors	1
Wall construction and R-value	Concrete block with brick veneer, R-7.5
Roof construction and R-value	Wood frame with built-up roof, R-13.5
Glazing type	Multipane; Shading-coefficient = 0.84 U-value = 0.72
Lighting power density	Sales area: 2.15 W/SF Storage area: 0.85 W/SF (Active) 0.45 W/SF (Inactive)
Plug load density	Sales area: 1.2 W/SF Storage area: 0.2 W/SF
Operating hours	10 – 10 Monday-Saturday 10 – 8 Sunday
HVAC system type	Packaged single zone, no economizer
HVAC system size	Based on ASHRAE design day conditions, 10% oversizing assumed.
Thermostat setpoints	Occupied hours: 75 cooling, 70 heating Unoccupied hours: 80 cooling, 65 heating

A computer-generated sketch of the small retail building prototype is shown in Figure 12.

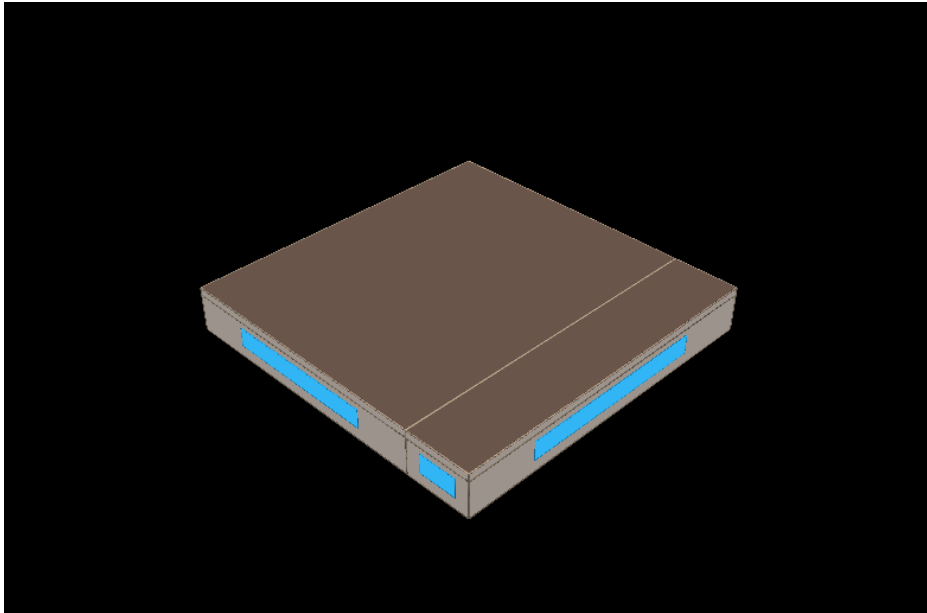

Figure 12. Small Retail Prototype Building Rendering

### Warehouse

A prototypical building energy simulation model for a warehouse building was developed using the DOE-2.2 building energy simulation program. The characteristics of the prototype are summarized in Table 30.

Table 30. Warehouse Prototype Building Description

Characteristic	Value
Vintage	Existing (1970s) vintage
Size	500,000
Number of floors	1
Wall construction and insulation R-value	Concrete block, R-5
Roof construction and insulation R-value	Wood deck with built-up roof, R-12
Glazing type	Multipane; Shading-coefficient = 0.84 U-value = 0.72
Lighting power density	0.9 W/SF
Plug load density	0.2 W/SF
Operating hours	Mon-Fri: 7am – 6pm Sat Sun: Unoccupied
HVAC system type	Packaged single zone, no economizer
HVAC system size	Based on ASHRAE design day conditions, 10% oversizing assumed.
Thermostat setpoints	Occupied hours: 80 cooling, 68 heating Unoccupied hours: 85 cooling, 63 heating

A computer-generated sketch of the prototype is shown in Figure 16.

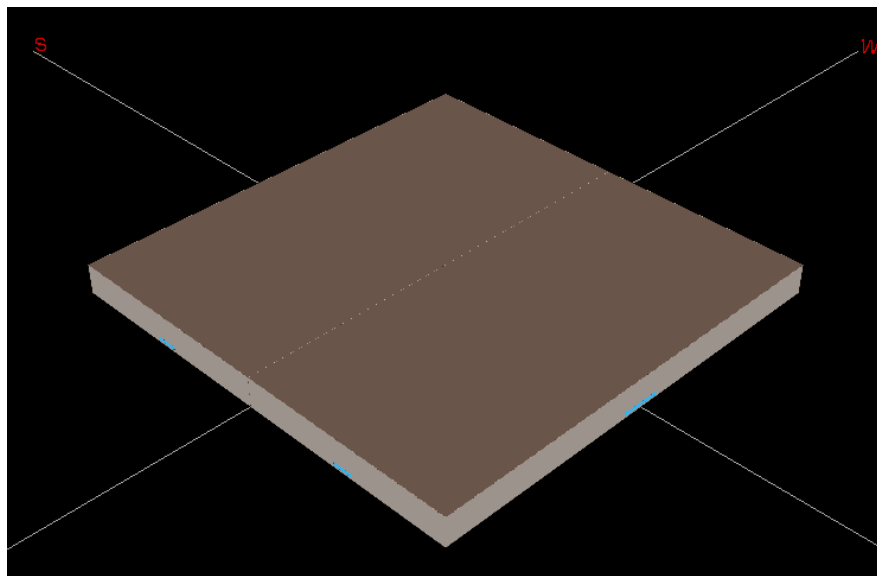

Figure 16. Warehouse Building Rendering

#### Commercial Building Measure Savings Analysis

Commercial building measures included efficiency upgrades to the heating and cooling equipment, HVAC control measures, building shell measures. A matrix of the measures and their applicability across each of the commercial building types is shown in Table 31 and 32. The assumptions used in the analysis are described in the following sections.

## Appendix A – Technical Resource Manual

## Ameren Missouri

Table 31. Measure Applicability by Small Commercial Building Type

	Assembly	Big Box Retail	Fast Food Restaurant	Full Service Restaurant	Grocery	Light Industrial	Primary School	Small Office	Small Retail	Warehouse
Anti Sweat Heater Control					✓					
Cool Roof	✓	✓	✓	✓		✓	✓	✓	✓	✓
Demand Controlled Ventilation Economizer	✓	✓	✓	✓		✓	✓	✓	✓	✓
Efficient Condenser					✓					
Engineered CKV hood			✓	✓						
Floating Head Pressure Control					✓					
Gas Furnace	✓	✓	✓	✓		✓	✓	✓	✓	✓
High Performance Glazing	✓	✓	✓	✓		✓	✓	✓	✓	✓
Infrared Heater						✓				✓
Night Covers					✓					
PTAC							✓	✓	✓	
PTAC-HP							✓	✓	✓	
Refrigerant Charge Correction	✓	✓	✓	✓		✓	✓	✓	✓	✓
Roof Insulation	✓	✓	✓	✓		✓	✓	✓	✓	✓
Rooftop Air Conditioners	✓	✓	✓	✓		✓	✓	✓	✓	✓
Rooftop Air Source Heat Pump	✓	✓	✓	✓		✓	✓	✓	✓	✓
Setback/Setup	✓	✓	✓	✓		✓	✓	✓	✓	✓
Water Loop Heat Pump	✓						✓	✓		
Window Film	✓	✓	✓	✓		✓	✓	✓	✓	✓

Table 32. Measure Applicability by Large Commercial Building Type

	Large Office	Hotel	Hospital
Air-Cooled Chiller	✓	✓	✓
Boiler	✓	✓	✓
CHW Reset	✓	✓	✓
Cool Roof	✓	✓	✓
Demand Controlled Ventilation	✓	✓	✓
Economizer	✓	✓	✓
Energy Management System	✓	✓	✓
Gas Engine Chiller	✓	✓	✓
High Performance Glazing	✓	✓	✓
Roof Insulation	✓	✓	✓
Setback/Setup	✓	✓	✓
VFD Fan	✓	✓	✓
VFD Pump	✓	✓	✓
Water-Cooled Chiller	✓	✓	✓
Window Film	✓	✓	✓



**HVAC Equipment Efficiency Upgrades**

The HVAC equipment efficiency measures include upgrades to single package rooftop air conditioners and heat pumps, split system air conditioners and heat pumps, packaged terminal air conditioners and heat pumps, and ground source and water loop heat pumps in a variety of size ranges. The program baseline is defined by the National Appliance Energy Conservation Act (NAECA) minimum efficiency for single phase equipment and ASHRAE 90.1 – 2004 minimum efficiency for three phase equipment. HVAC measures cover the upgrade of standard efficiency packaged HVAC systems with high efficiency versions of the same equipment. A separate set of simulations were conducted to address the energy savings associated with changing from a rooftop air cooled heat pump system to a ground-source heat pump system in selected building types.

The HVAC equipment covered, the size ranges, and the program baseline efficiency assumptions are shown in Table 33.

**Table 33. Unitary HVAC Equipment Measure Efficiency Assumptions**

Equipment Category	Capacity Range (Btu/hr)	Baseline Efficiency	Baseline Source	Measure Efficiency
Packaged Terminal A/C	All	8.9 EER	ASHRAE 90.1-2004	9.2
Packaged Terminal HP	All	8.7 EER	ASHRAE 90.1-2004	9.0
Unitary A/C (1 ) phase	<65,000 1 Ph	13.0 SEER	NAECA	14.0
Unitary A/C (3) phase	<65,000 3 Ph	12.0 SEER	ASHRAE 90.1-2004	13.0
Unitary A/C (3) phase	65,000 - 135,000	10.1 EER	ASHRAE 90.1-2004	11.0
Unitary A/C (3) phase	135,000 - 240,000	9.5 EER	ASHRAE 90.1-2004	11.0
Unitary A/C (3) phase	240,000 - 760,000	9.3 EER	ASHRAE 90.1-2004	10.0
Unitary A/C (3) phase	>760,000	9.0 EER	ASHRAE 90.1-2004	10.0
Unitary HP (1) phase	<65,000 1 Ph	13.0 SEER	NAECA	14.0
Unitary HP (3) phase	<65,000 3 Ph	12.0 SEER	ASHRAE 90.1-2004	13.0
Unitary HP (3) phase	65,000 - 135,000	9.9 EER	ASHRAE 90.1-2004	11.0
Unitary HP (3) phase	135,000 - 240,000	9.1 EER	ASHRAE 90.1-2004	10.0
Unitary HP (3) phase	>240,000	8.8 EER	ASHRAE 90.1-2004	10.0
Ground Source HP	<135,000 & 77F EWT	13.4 EER	ASHRAE 90.1-2004	17 EER and 19

## Appendix A – Technical Resource Manual

## Ameren Missouri

Equipment Category	Capacity Range (Btu/hr)	Baseline Efficiency	Baseline Source	Measure Efficiency
				EER
Water Loop Heat Pump	<17,000 & 86F EWT	11.2 EER	ASHRAE 90.1-2004	11.5
Water Loop Heat Pump	17,000 - 65,000 & 86F EWT	12.0 EER	ASHRAE 90.1-2004	12.3
Water Loop Heat Pump	65,000 - 135,000 & 86F EWT	12.0 EER	ASHRAE 90.1-2004	12.3

Rooftop AC units with gas heat were simulated with high efficiency gas heating sections. The simulations modeled improvement from a 78 AFUE baseline furnace section to a 95 AFUE furnace.

An infrared heater simulation was conducted for the light manufacturing prototype, where the baseline system was a standard efficiency gas unit heater. Energy savings from the infrared heating system were simulated by lowering the room heating temperature setpoint by 5 degrees F and eliminating the fan energy consumption. Combustion efficiency between the baseline unit heater and the infrared heater was assumed to remain constant.

Chiller efficiency improvements were analyzed for the Large Office prototype. The efficiency scenarios covered a range of full load and part load Integrated Part Load Value (IPLV) efficiencies for air cooled reciprocating and screw chillers; and water cooled screw and centrifugal chillers of various size ranges. Full load efficiency improvements of 10% and 20% were evaluated. The 10% improvement is coincident with the Federal Energy Management Program (FEMP) program guidelines, while the 20% efficiency improvement was run as an aggressive case. Part load (IPLV) improvement scenarios were run at each full-load efficiency level, covering a range of IPLV improvements available from variable speed drive chillers. An efficient gas engine chiller was also simulated relative to a standard gas engine chiller baseline. The baseline and efficient equipment efficiencies are summarized in Table 34.

**Table 34. Chiller Measure Efficiency Assumptions**

Equipment Category	Capacity Range (Btu/hr)	Baseline Full-load Efficiency (kW/ton)	Baseline IPLV (kW/ton)	Measure Efficiency (kW/ton)	Measure IPLV (kW/ton)
Air-Cooled Chiller	All	1.26	1.15	1.05 – 1.14	0.62 – 1.02
Water-Cooled Screw Chiller	<150 tons	0.79	0.68	0.63 - 0.79	0.38 – 0.62
	150 – 300 ton	0.72	0.63	0.57 – 0.72	0.34 - 0.57
	> 300 ton	0.64	0.57	0.51 - .064	0.31 -0.51
Water-Cooled Centrifugal Chiller	<150 tons	0.70	0.67	0.56 - 0.7	0.34 - 0.60
	150 – 300 ton	0.63	0.60	0.51 – 0.63	0.30 - 0.54
	> 300 ton	0.58	0.55	0.46 – 0.58	0.29 - 0.49
Gas Engine Chiller	All	1.6 COP		1.76 COP	

High efficiency boilers were applied to the Large Office prototype, assuming a thermal efficiency of 80% in the base case and 85% for the measure.

### **HVAC Control Measures**

A series of HVAC control and system tune-up measures were also analyzed. Dual temperature air side economizer systems were added to both packaged rooftop and built-up systems. Chilled water reset controls were analyzed for both air cooled and water cooled chiller systems. Variable frequency drives on air handlers and pumps were analyzed. The VFD fan applications simulated VFDs applied to both the supply and return fans of the VAV built up system air handlers in the large commercial buildings. Inlet vane control was assumed in the base case. VFD pumping applications were simulated by applying a VFD to the secondary loop of a constant volume primary/secondary pumping system. Three-way chilled water coil control valves were assumed in the base case, while the variable flow case assumed two-way control valves.

Demand controlled ventilation (DCV) systems were simulated by adding an air-side economizer with zone-level CO<sub>2</sub> sensor controls to the packaged rooftop equipment, thus the savings represent the combined effect of the DCV and the air side economizer. For the built up systems using in the large commercial building prototypes, outdoor air volume control based on return air CO<sub>2</sub> sensors was simulated. The simulations calculated the effect of the DCV controls only. In all cases, minimum outside ventilation rates tracked the occupancy schedules used to define the prototypes.

Setback thermostats (assumed to be present in the base building) were analyzed by comparing the baseline building simulations to a no-setback simulation. A refrigerant charge adjustment measure was analyzed for rooftop air conditioners. The simulations assumed an undercharged scenario where the charge correction improved the unit efficiency by 10%.

A simple EMS upgrade was simulated by combining the chilled water reset controls with hot water, chilled water and condenser pump on/off controls that turn the pumps off when heating and/or cooling are not needed.

The HVAC control and system tune-up measure assumptions are summarized in Table 35.

**Table 35. HVAC Control and System Tune-up Measure Assumptions**

Measure	Baseline Assumption	Measure Assumption
Chilled Water Reset – Air-Cooled Chiller	45°F fixed chilled-water temperature setpoint	Chilled-water temperature allowed to increase by 5°F or 10°F during periods of low load.
Chilled Water Reset – Water-Cooled Chiller	45°F fixed chilled-water temperature setpoint	Chilled-water temperature allowed to increase by 5°F or 10°F during periods of low load.
Demand controlled ventilation	Fixed outside air without economizer	Dual temperature air-side economizer with zone-level CO <sub>2</sub> sensors for rooftop units; return system CO <sub>2</sub> sensors for built up systems.

## Appendix A – Technical Resource Manual

## Ameren Missouri

Measure	Baseline Assumption	Measure Assumption
Economizer	Fixed outside air without economizer	Dual temperature air-side economizer
Setback Thermostat	No setback/setup during unoccupied hours	Temperatures are setback/setup during unoccupied hours
Refrigerant Charge adjustment for rooftop AC	Cooling capacity and EIR degraded by 10% to reflect “typical” refrigerant charge	Standard cooling performance – proper refrigerant charge
VFD on air-handler fan	Inlet vane controlled VAV	VSD controlled VAV
VFD on chilled-water pumps	3-way valve with single-speed chilled-water pump	VSD controlled chilled-water pump with 2 way control valves
EMS	Constant chilled water temperature setpoint, loop pumps operating 24/7	Chilled water temperature setback and on/off scheduling of loop pumps

**Shell Measures**

Shell measures included window films applied to the existing double pane clear glass, high performance tinted low-e glazing compliant with ASHRAE 90.1-2004, upgraded roof insulation and “cool roofs.” A summary of the shell measure assumptions is shown in Table 36.

**Table 36. Shell Measure Assumptions**

Measure	Baseline Assumption	Measure Assumption
High Performance Glazing	Clear, double-pane Shading-coefficient = .84 U-value = .72	SHGC = 0.39 U-value = 0.57
Window Film		SHGC = 0.39 U-value = .72
Roof insulation	Varies by prototype	R-18
Cool roof	Solar absorptance = 0.8	Solar absorptance = 0.3

**Refrigeration Measures**

The grocery store prototype building was used to analyze a set of refrigeration measures. The measures included efficient air-cooled condensers, floating head pressure control, night covers and anti-sweat heater controls. The air cooled condenser measure assumed an oversized condenser with improved condenser fan efficiency. The base case condenser assumed a 15°F temperature difference between the condensed liquid and outdoor air temperature under design conditions for low temperature systems and a 20°F temperature difference for medium temperature systems. The efficient case assumed the temperature difference of 8°F and 13°F for low and medium temperature systems respectively. The

efficiency of the fan was also considered. The base system assumed 45 Btu/hr of heat rejection<sup>14</sup> per watt of fan power, while the efficient case assumed 85 Btu/hr of heat rejection per watt of fan power.

Floating head pressure controls were simulated by allowing the condenser fans to run until a 70°F condensing temperature was achieved compared to an 85°F condensing temperature in the base case. Night covers were simulated by reducing the infiltration rate on medium temperature open multi-deck cases by 50% for 4 hours per day while the night covers were deployed. Anti-sweat heater controls were simulated by controlling the door anti-sweat heaters on low temperature reach-in cases according to store dewpoint temperature. Door heater energy is reduced starting at a dewpoint temperature setpoint of 55°F and are shut off completely at a 33°F dewpoint temperature. Door heaters are assumed to run continuously in the base case.

The refrigeration measure assumptions are summarized in Table 37.

**Table 37. Grocery Refrigeration Measure Assumptions**

Measure	Baseline Assumption	Measure Assumption
Efficient Refrigeration Condenser	Low Temp: 15°F approach; 45 Btu/hr - watt Medium Temp: 20°F approach; 45 Btu/hr - watt	Low Temp: 8°F approach; 85 Btu/hr-watt Medium Temp: 13°F approach; 85 Btu/hr-watt
Floating Head Pressure Control	SCT controlled to 85°F fixed setpoint	SCT controlled to 70°F setpoint
Night Covers on Open Case	Open cases with no night cover	Open cases covered 4 hrs/night Reduces infiltration by 50%
Anti-Sweat Heater Controls	Uncontrolled anti-sweat heaters on case doors	Anti-sweat heaters controlled based on store interior dewpoint temperature.

### Other Measures

The impacts of engineered commercial kitchen ventilation (CKV) systems were simulated for the fast food and full service restaurant buildings. Engineered CKV systems can reduce the ventilation rates for the cookline ventilation hoods by 50% to 60%. The size of the hoods and the ventilation air requirements vary widely by restaurant, so the impacts of this technology were normalized per 100 cfm of ventilation air reduction. The makeup air for the system is assumed to be introduced through the kitchen HVAC systems, rather than through a dedicated makeup air heater.

### Simulation Results

Annual kWh, summer and winter peak kW, and gas therm savings estimates were developed based on differences between the simulated energy consumption and peak demand at the baseline and the

<sup>14</sup> Heat rejection rates are based on a 10 degree F temperature difference for this specification.

measure efficiency levels. Summer peak demand was assumed to occur during the month of July, while winter peak impacts were calculated during the month of January. The set of simulations described above were conducted for St. Louis, MO. The TMY3 long term average weather data set was used. The simulated savings were normalized using appropriate units – tons for cooling measures, 100 square feet of window area for window measures, etc.

Measure cost data were compiled from a combination of the DEER database and cost estimation conducted by Franklin Energy. Base case equipment costs, measure costs, and labor costs to install the equipment were compiled. The incremental costs are reported as the difference between the baseline and measure equipment costs, exclusive of labor costs. The installed costs are the sum of the measure costs and the installation labor costs. First costs only are reported; incremental maintenance costs are assumed to be zero.

The base case for most of the measures in this study assumes a normal replacement scenario, where the equipment has reached the end of its service life and must be replaced. The energy savings are evaluated against standard efficiency replacement equipment (assumed to be either code or standard industry practice). In these instances, the incremental measure costs should be used to evaluate measure cost effectiveness.

Normalized measure savings and cost data are included in a separate electronic file. The energy and cost data are all normalized to the same units. A typical measure sized is included as appropriate to estimate the energy savings and costs for a typical measure in each size range.

Program	Measure	Low Range	High Range
Direct Install	AC - Energy Star Room - Thru-Wall	\$ 250.00	\$ 1,000.00
Direct Install	AC - Energy Star Room_MF	\$ 197.50	\$ 790.00
Direct Install	AC - SEER 14_MF	\$ 69.46	\$ 277.86
Direct Install	AC - SEER 15_MF	\$ 138.93	\$ 555.71
Direct Install	AC - SEER 16_MF	\$ 208.39	\$ 833.57
Direct Install	AC - SEER 17_MF	\$ 277.86	\$ 1,111.42
Direct Install	Airtight Can Lights_MF	\$ 75.00	\$ 300.00
Direct Install	ASHP - SEER 14_MF	\$ 73.45	\$ 375.00
Direct Install	ASHP - SEER 15_MF	\$ 146.90	\$ 600.00
Direct Install	ASHP - SEER 16_MF	\$ 220.36	\$ 900.00
Direct Install	ASHP - SEER 17_MF	\$ 293.81	\$ 1,175.23
Direct Install	ASHP - SEER 18_MF	\$ 367.26	\$ 1,500.00
Direct Install	CFL - 13W_MF POST-EISA	\$ 2.50	\$ 10.00
Direct Install	CFL - 13W_MF PRE-EISA	\$ 2.50	\$ 10.00
Direct Install	CFL - 18W (75W incand equiv) POST-EISA	\$ 2.50	\$ 10.00
Direct Install	CFL - 23W (100W incand equiv) POST-EISA	\$ 2.50	\$ 10.00
Direct Install	CFL - Fixtures	\$ 9.00	\$ 36.00
Direct Install	CFL - High Wattage Bulbs	\$ 7.50	\$ 40.00
Direct Install	CFL - Reflector	\$ 7.50	\$ 30.00
Direct Install	CFL - Specialty Bulbs	\$ 5.00	\$ 30.00
Direct Install	DFHP - SEER 14_MF	\$ 69.46	\$ 300.00
Direct Install	DFHP - SEER 15_MF	\$ 138.93	\$ 600.00
Direct Install	DFHP - SEER 16_MF	\$ 208.39	\$ 850.00
Direct Install	DFHP - SEER 17_MF	\$ 277.86	\$ 1,200.00
Direct Install	DFHP - SEER 18_MF	\$ 366.75	\$ 1,500.00
Direct Install	Duct Insulation_MF	\$ 264.00	\$ 1,500.00
Direct Install	Duct location_MF	\$ 825.00	\$ 3,300.00
Direct Install	Duct sealing 20% leakage base_MF	\$ 150.00	\$ 949.61
Direct Install	Duct sealing 25% leakage base_MF	\$ 150.00	\$ 949.61
Direct Install	Duct sealing 30% leakage base_MF	\$ 150.00	\$ 949.61
Direct Install	ECM blower - continuous_MF	\$ 131.25	\$ 525.00
Direct Install	ECM blower - intermittent_MF	\$ 131.25	\$ 525.00
Direct Install	Energy Star Refrigerator_MF	\$ 340.00	\$ 1,400.00
Direct Install	HVAC Maintenance and Tune-up_MF	\$ 34.75	\$ 300.00
Direct Install	LED - 10.5W Downlight E26 Light Bulb	\$ 16.49	\$ 65.94
Direct Install	LED - 12W Dimmable Light Bulb	\$ 16.49	\$ 65.94
Direct Install	LED - 15W Flood Light PAR30 Bulb (Post-EISA)	\$ 16.49	\$ 65.94
Direct Install	LED - 18W Flood Light PAR38 Bulb (Post-EISA)	\$ 16.49	\$ 65.94
Direct Install	LED - 8W Globe Light G25 Bulb	\$ 11.49	\$ 45.94
Direct Install	Low Flow Faucet Aerator_MF	\$ 6.50	\$ 26.00
Direct Install	Low Flow Showerhead_MF	\$ 21.00	\$ 84.00
Direct Install	Pipe Insulation_MF	\$ 2.50	\$ 15.00
Direct Install	PTAC 10.3 EER_MF	\$ 62.15	\$ 248.58
Direct Install	PTAC 9.3 EER_MF	\$ 67.80	\$ 271.18
Direct Install	PTHP 10.9 EER_MF	\$ 77.56	\$ 310.23
Direct Install	PTHP 9.1 EER_MF	\$ 84.61	\$ 338.43
Direct Install	RCA 10% improvement_MF	\$ 34.75	\$ 225.00
Direct Install	RCA 15% improvement_MF	\$ 109.70	\$ 438.81
Direct Install	RCA 5% improvement_MF	\$ 28.77	\$ 115.08
Direct Install	Refrigerator Coil Cleaning Brush	\$ 1.50	\$ 9.00
Direct Install	Setback thermostat - full setback_MF	\$ 45.00	\$ 180.00
Direct Install	Smart Strip plug outlet	\$ 20.00	\$ 80.00
Direct Install	Wall Insulation_MF	\$ 1,520.56	\$ 3,040.00
Direct install	Water Heater, Tank Blanket-Insulation - Electric	\$ 12.50	\$ 150.00
Direct Install	Water Heater, Thermostat Setback - Electric	\$ 4.00	\$ 16.00
Direct Install	Window Film_MF	\$ 269.18	\$ 540.00
Direct Install	Window Replacement_MF	\$ 750.10	\$ 1,500.00
	Air Sealing (Infiltration reduction) - 30%_SF	\$ 35.00	\$ 264.00
	Air Sealing (Infiltration reduction) - 50%_SF	\$ 35.00	\$ 264.00
	ASHP - SEER 14 ER Elec Resist Furnace ERbegin	\$ 149.63	\$ 950.00

Program	Measure	Low Range	High Range
	ASHP - SEER 14 ER with ASHP ERbegin	\$ 160.99	\$ 750.00
	ASHP- SEER 14 Replace at Fail Elec Resist Furnace	\$ 96.30	\$ 950.00
	ASHP - SEER 14 Replace at Fail with ASHP	\$ 61.65	\$ 411.00
	ASHP - SEER 15 ER Elec Resist Furnace ERbegin	\$ 160.73	\$ 1,100.00
	ASHP - SEER 15 ER Elec Resist Furnace ERbegin	\$ 160.73	\$ 1,100.00
	ASHP - SEER 15 ER with ASHP ERbegin	\$ 177.64	\$ 1,000.00
	ASHP - SEER 15 ER with ASHP ERbegin	\$ 216.06	\$ 1,000.00
	ASHP- SEER 15 Replace at Fail Elec Resist Furnace	\$ 107.40	\$ 1,074.00
	ASHP- SEER 15 Replace at Fail Elec Resist Furnace	\$ 107.40	\$ 1,075.00
	ASHP - SEER 15 Replace at Fail with ASHP	\$ 78.30	\$ 522.00
	ASHP - SEER 15 Replace at Fail with ASHP	\$ 104.40	\$ 523.00
	ASHP - SEER 16+ ER Elec Resist Furnace ERbegin	\$ 201.83	\$ 1,500.00
	ASHP - SEER 16+ ER Elec Resist Furnace ERbegin	\$ 201.83	\$ 1,500.00
	ASHP - SEER 16+ ER with ASHP ERbegin	\$ 239.29	\$ 1,300.00
	ASHP - SEER 16+ ER with ASHP ERbegin	\$ 319.05	\$ 1,300.00
	ASHP- SEER 16+ Replace at Fail Elec Resist Furnace	\$ 148.50	\$ 1,485.00
	ASHP- SEER 16+ Replace at Fail Elec Resist Furnace	\$ 148.50	\$ 1,486.00
	ASHP - SEER 16+ Replace at Fail with ASHP	\$ 139.95	\$ 933.00
	ASHP - SEER 16+ Replace at Fail with ASHP	\$ 186.60	\$ 934.00
	CAC - SEER 14 ERbegin	\$ 133.55	\$ 750.00
	CAC - SEER 14 Replace at Fail	\$ 53.55	\$ 357.00
	CAC - SEER 15 ERbegin	\$ 187.10	\$ 1,000.00
	CAC - SEER 15 Replace at Fail	\$ 107.10	\$ 714.00
	CAC - SEER 16+ ERbegin	\$ 195.65	\$ 1,200.00
	CAC - SEER 16+ Replace at Fail	\$ 115.65	\$ 771.00
	Ceiling Insulation R5-R30	\$ 0.00075	\$ 0.0030
	Ceiling Insulation R5-R38	\$ 0.00075	\$ 0.0030
	Ceiling Insulation R5-R49	\$ 0.00075	\$ 0.0030
	Ceiling Insulation R11-R30	\$ 0.00075	\$ 0.0030
	Ceiling Insulation R11-R38	\$ 0.00075	\$ 0.0030
	Ceiling Insulation R11-R49	\$ 0.00075	\$ 0.0030
	Ceiling Insulation R19-R30	\$ 0.00075	\$ 0.0030
	Ceiling Insulation R19-R38	\$ 0.00075	\$ 0.0030
	Ceiling Insulation R19-R49	\$ 0.00075	\$ 0.0030
	CFL - 13W (60W incand equiv) POST-EISA	\$ 0.33	\$ 2.50
	CFL - 13W (60W incand equiv) PRE-EISA	\$ 0.33	\$ 2.50
	CFL - 18W (75W incand equiv) POST-EISA	\$ 0.33	\$ 2.50
	CFL - 23W (100W incand equiv) POST-EISA	\$ 0.33	\$ 2.50
	CFL - Fixtures	\$ 3.75	\$ 30.00
	CFL - High Wattage Bulbs	\$ 1.50	\$ 6.00
	CFL - Reflector	\$ 1.50	\$ 8.00
	CFL - Specialty Bulbs	\$ 1.50	\$ 10.50
	CFL - Torchiere Floor Lamps	\$ 7.50	\$ 30.00
	DFHP - SEER 14_SF	\$ 38.14	\$ 250.00
	DFHP - SEER 15_SF	\$ 76.27	\$ 450.00
	DFHP - SEER 16_SF	\$ 114.41	\$ 650.00
	DFHP - SEER 17_SF	\$ 152.54	\$ 850.00
	DFHP - SEER 18_SF	\$ 201.35	\$ 1,100.00
	Duct Sealing Level 1	\$ 48.75	\$ 325.00
	Duct Sealing Level 2	\$ 32.50	\$ 325.00
	ECM Installations Auto Fan ERbegin	\$ 15.00	\$ 167.75
	ECM Installations Auto Fan Replace at Fail	\$ 15.00	\$ 125.00
	ECM Installations Continuous Fan ERBegin	\$ 15.00	\$ 167.75
	ECM Continuous Fan Replace at Fail	\$ 15.00	\$ 125.00
	Energy Star Room AC	\$ 7.50	\$ 50.00
	Energy Star Room Air Purifier	\$ 25.00	\$ 70.00
	Energy Star Water Cooler	\$ 8.50	\$ 17.00
	Freezer Recycling	\$ 25.00	\$ 100.00
	Geothermal HP Desuperheater	\$ 23.90	\$ 100.00
	GSHP - SEER 14+ ER ASHP with GSHP ERbegin	\$ 724.09	\$ 3,860.00



Program	Measure	Low Range	High Range
	GSHP - SEER 14+ ER Elec Resist Furnace Erbegin	\$ 400.00	\$ 1,600.00
	GSHP - SEER 14+ Replace Elec Resist Furnace	\$ 400.00	\$ 1,600.00
	Heat Pump Strip Installed	\$ 15.38	\$ 75.00
	Heat Pump Strip Reset	\$ 2.50	\$ 25.00
	Heat Pump Water Heaters	\$ 125.00	\$ 700.00
	HID - Exterior	\$ 8.49	\$ 33.94
	HVAC Maintenance and Tune-up_SF	\$ 19.44	\$ 130.00
	Indoor Coil Cleaning	\$ 6.25	\$ 62.50
	LED - 10.5W Downlight E26 Light Bulb	\$ 4.00	\$ 30.00
	LED - 12W Dimmable Light Bulb	\$ 4.00	\$ 30.00
	LED - 15W Flood Light PAR30 Bulb (POST-EISA)	\$ 4.00	\$ 30.00
	LED - 18W Flood Light PAR38 Bulb (POST-EISA)	\$ 4.00	\$ 30.00
	LED - 8W Globe Light G25 Bulb	\$ 4.00	\$ 30.00
	Level 1 Home Audit	\$ 0.00	\$ 300.00
	Level 2 Home Audit	\$ 0.00	\$ 300.00
	Low Flow Faucet Aerator - Electric water heater	\$ 0.95	\$ 5.00
	Low Flow Showerhead - Electric water heater	\$ 3.16	\$ 15.00
	Metal Halide Outdoor Lighting	\$ 16.80	\$ 67.20
	Occupancy Sensor	\$ 5.00	\$ 49.00
	Outdoor Coil Cleaning	\$ 3.13	\$ 31.25
	Pipe Wrap - Electric water heater	\$ 0.76	\$ 7.60
	Pool Pump and Motor Single Speed	\$ 8.50	\$ 85.00
	Pool Pump and motor w auto controls - multi speed	\$ 86.85	\$ 400.00
	PTAC 10.3 EER_SF	\$ 18.64	\$ 124.29
	PTAC 9.3 EER_SF	\$ 20.34	\$ 135.59
	PTHP 10.9 EER_SF	\$ 23.27	\$ 150.00
	PTHP 9.1 EER_SF	\$ 25.38	\$ 150.00
	RCA 10% improvement_SF	\$ 19.08	\$ 127.19
	Refrigerator Recycling	\$ 25.00	\$ 100.00
	Setback thermostat - full setback_SF	\$ 6.34	\$ 50.00
	Setback thermostat - moderate setback_SF	\$ 7.34	\$ 50.00
	Smart Strip plug outlet	\$ 5.00	\$ 25.00
	VFDs on Residential Swimming Pool Pumps	\$ 63.75	\$ 255.00
	Water Heater - Electric	\$ 7.35	\$ 49.00
	Water Heater, Tank Blanket-Insulation - Electric	\$ 1.80	\$ 18.00
	Water Heater, Thermostat Setback - Electric	\$ 0.80	\$ 8.00
	Window Replacement_SF	\$ 225.03	\$ 900.12

Measure	Low \$/kWh	High \$/kWh
Custom Measures	\$0.0400	\$0.1800
AC less than 65,000 1 Ph	\$0.1226	\$0.1800
AC greater than 760,000	\$0.0868	\$0.1800
AC 135,000 - 240,000	\$0.0672	\$0.1800
GSHP under 135,000 17EER	\$0.0400	\$0.1800
GSHP under 135,000 19EER	\$0.0400	\$0.1800
HP under 65,000 1 Ph	\$0.0400	\$0.2000
HP over 240,000	\$0.0260	\$0.2000
HP 135,000 - 240,000	\$0.0317	\$0.2000
Setback-Setup Thermostat	\$0.0400	\$0.1769
Wtr-Cool cent Chiller over 300 ton 0.46 kWperTon with 0.35 kWperTon IPLV	\$0.0400	\$0.1800
Wtr-Cool cent Chiller over 300 ton 0.52 kWperTon with 0.49 kWperTon IPLV	\$0.0400	\$0.1800
Wtr-Cool cent Chiller over 300 ton 0.58 kWperTon with 0.41 kWperTon IPLV	\$0.0400	\$0.1800
Wtr-Cool cent Chiller 150 - 300 ton 0.51 kWperTon with 0.39 kWperTon IPLV	\$0.0400	\$0.1800
Wtr-Cool cent Chiller 150 - 300 ton 0.57 kWperTon with 0.43 kWperTon IPLV	\$0.0400	\$0.1800
Wtr-Cool cent Chiller 150 - 300 ton 0.63 kWperTon with 0.45 kWperTon IPLV	\$0.0400	\$0.1800
Wtr-Cool Centrifugal Chiller under 150 ton 0.56 kWperTon with 0.43 kWperTon IPLV	\$0.0400	\$0.1800
Wtr-Cool Centrifugal Chiller under 150 ton 0.63 kWperTon with 0.48 kWperTon IPLV	\$0.0400	\$0.1800
Wtr-Cool Centrifugal Chiller under 150 ton 0.7 kWperTon with 0.5 kWperTon IPLV	\$0.0400	\$0.1800
Wtr-Cool screw chiller under 150 ton 0.63 kWperTon with 0.44 kWperTon IPLV	\$0.0400	\$0.1800
Wtr-Cool screw chiller under 150 ton 0.71 kWperTon with 0.5 kWperTon IPLV	\$0.0400	\$0.1800
Wtr-Cool screw chiller under 150 ton 0.79 kWperTon with 0.55 kWperTon IPLV	\$0.0400	\$0.1800
Wtr-Cool screw chiller over 300 ton 0.51 kWperTon with 0.36 kWperTon IPLV	\$0.0400	\$0.1800
Wtr-Cool screw chiller over 300 ton 0.58 kWperTon with 0.4 kWperTon IPLV	\$0.0400	\$0.1800
Wtr-Cool screw chiller over 300 ton 0.64 kWperTon with 0.45 kWperTon IPLV	\$0.0400	\$0.1800
Wtr-Cool screw chiller 150 - 300 ton 0.57 kWperTon with 0.4 kWperTon IPLV	\$0.0400	\$0.1800
Wtr-Cool screw chiller 150 - 300 ton 0.65 kWperTon with 0.45 kWperTon IPLV	\$0.0400	\$0.1800
Wtr-Cool screw chiller 150 - 300 ton 0.72 kWperTon with 0.5 kWperTon IPLV	\$0.0400	\$0.1800
High Bay 3L T5HO Replacing 250W HID	\$0.0400	\$0.0361
High Bay 6L T5HO Double fixture replace 1000W HID	\$0.0400	\$0.0433
Pulse Start Metal Halide 150-200W retrofit only	\$0.0400	\$0.0513
Pulse Start Metal Halide 320W retrofit only	\$0.0400	\$0.0381
Pulse Start Metal Halide 750W retrofit only	\$0.0367	\$0.0132
Ceramic Metal Halide 20-100W	\$0.0400	\$0.0455
Garage HID replacement above 175W to 250W HID retrofit	\$0.0400	\$0.0481
Garage HID replacement above 250W to 400W HID retrofit	\$0.0400	\$0.0446
CFL Screw in	\$0.0050	\$0.0099
CFL Screw high wattage	\$0.0060	\$0.0241
LED Lamps - pre-EISA	\$0.0400	\$0.1130
CFL Reflector Flood	\$0.0050	\$0.0198
HP Water Heater 10 to 50 MBH	\$0.0400	\$0.1800
HP Water Heater 50 to 100 MBH	\$0.0400	\$0.1800
HP Water Heater 100 to 300 MBH	\$0.0400	\$0.1773
HP Water Heater 300 to 500 MBH	\$0.0400	\$0.1489
HP Water Heater above 500 MBH	\$0.0400	\$0.1489
Pumps HP 3	\$0.0400	\$0.1800
Pumps HP 5	\$0.0400	\$0.1800
Pumps HP 7.5	\$0.0400	\$0.1800
Pumps HP 10	\$0.0400	\$0.1648
Pumps HP 15	\$0.0400	\$0.1800
Pumps HP 20	\$0.0400	\$0.1800
VFD HP 3 Process Pumping	\$0.0400	\$0.1800
VFD HP 5 Process Pumping	\$0.0400	\$0.1800
VFD HP 7.5 Process Pumping	\$0.0400	\$0.1800
VFD HP 10 Process Pumping	\$0.0400	\$0.1800

VFD HP 15 Process Pumping	\$0.0400	\$0.1800
VFD HP 20 Process Pumping	\$0.0400	\$0.1800
VFD HP 25 Process Pumping	\$0.0400	\$0.1800
VFD HP 30 Process Pumping	\$0.0400	\$0.1777
VFD HP 40 Process Pumping	\$0.0400	\$0.1800
VFD HP 50 Process Pumping	\$0.0400	\$0.1654
VFDs on Commercial Swimming Pool Pumps	\$0.0400	\$0.1139
ENERGY STAR Commercial Solid Door Freezers less than 15ft3	\$0.0400	\$0.1800
ENERGY STAR Commercial Solid Door Freezers 15 to 30 ft3	\$0.0400	\$0.1800
ENERGY STAR Commercial Solid Door Freezers 30 to 50ft3	\$0.0400	\$0.1800
ENERGY STAR Commercial Solid Door Freezers more than 50ft3	\$0.0400	\$0.1800
ENERGY STAR Commercial Glass Door Refrigerators less than 15ft3	\$0.0400	\$0.1800
ENERGY STAR Commercial Glass Door Refrigerators 15 to 30 ft3	\$0.0400	\$0.1800
ENERGY STAR Commercial Glass Door Freezers less than 15ft3	\$0.0400	\$0.1299
ENERGY STAR Commercial Glass Door Freezers 15 to 30 ft3	\$0.0400	\$0.1800
ENERGY STAR Commercial Glass Door Freezers 30 to 50ft3	\$0.0400	\$0.1800
ENERGY STAR Commercial Glass Door Freezers more than 50ft3	\$0.0400	\$0.1800
ENERGY STAR Ice Machines less than 500 lbs	\$0.0400	\$0.1800
ENERGY STAR Ice Machines 500 to 1000 lbs	\$0.0400	\$0.1800
ENERGY STAR Ice Machines more than 1000 lbs	\$0.0400	\$0.1800
ENERGY STAR Steam Cookers 3 Pan - Electric	\$0.0400	\$0.1800
ENERGY STAR Steam Cookers 4 Pan - Electric	\$0.0400	\$0.1800
ENERGY STAR Steam Cookers 5 Pan - Electric	\$0.0400	\$0.1800
ENERGY STAR Steam Cookers 6 Pan - Electric	\$0.0400	\$0.1800
ENERGY STAR Hot Holding Cabinets Full Size - Electric	\$0.0400	\$0.1800
Pre Rinse Sprayers - Electric water heater	\$0.0036	\$0.0119
Window replacement	\$0.0400	\$0.1800
Low Flow Faucet Aerator - Electric water heater	\$0.0288	\$0.0576
Tractor Heater Timers	\$0.0400	\$0.0608
Induction Street Lighting - 85W Sylvania Cobra head	\$0.0400	\$0.1800 ok
1_7W LED	\$0.0400	\$0.1800
4L T9	\$0.0400	\$0.1800
6L T8	\$0.0400	\$0.1800
Built-in to individual fixtures	\$0.0400	\$0.1800 ok
Dual Technology Sensors (more than 150 Watts)	\$0.0400	\$0.1662
GU-24 pin-based CFL - 30W	\$0.0122	\$0.0268 ok
Interior Ceiling (6 fixtures controlled)	\$0.0400	\$0.1695 ok
Interior CF 1L 26W Quad	\$0.0400	\$0.1235 ok
Interior CF 1L 32W Triple	\$0.0400	\$0.1800
Interior High-Bay T5 (3 fix. Controlled)	\$0.0400	\$0.1800
Interior Wall (3 fixtures controlled)	\$0.0400	\$0.1466
High Bay Fluorescent 4LF32T8 Replacing 250W HID	\$0.0244	\$0.1800
High Bay Fluorescent 6LF32T8 Replacing 400W HID	\$0.0364	\$0.1665
High Bay Fluorescent 8LF32T8 Replacing 400W HID	\$0.0539	\$0.1800
High Bay Fluorescent 8LF32T8 Double fixture replace 1000W HID	\$0.0400	\$0.1800
LED Exit Sign - 3_0 W_CF 18 Base	\$0.0400	\$0.1800
LED Exit Sign - 3_0 W_CF 9 base	\$0.0400	\$0.1769
LED Exit Sign - 3_0 W_Inc30 base	\$0.0400	\$0.1800
LED or Electroluminescent Exit Sign	\$0.0400	\$0.1800
New pin-based CFL Fixture (_GT_45W)	\$0.0400	\$0.1800
Passive Infrared or Ultrasonic	\$0.0243	\$0.1490
Passive Infrared or Ultrasonic_2	\$0.0243	\$0.1331
T5 High-Bay 4L-F54HO_high	\$0.0400	\$0.1800
T5 High-Bay 4L-F54HO_lo	\$0.0400	\$0.1800
T5 High-Bay 6L-F54HO_med2	\$0.0400	\$0.1800
T5 High-Bay 6L-F54HO_high	\$0.0400	\$0.1722
T8 8L High-Bay	\$0.0400	\$0.1800
Anti-Sweat Heater Controls -- Cooler	\$0.0400	\$0.1105
Beverage Vending Machine Control	\$0.0400	\$0.0855
ENERGY STAR Vending Machine	\$0.0400	\$0.1400

Lighted Snack Dispensing Machine	\$0.0400	\$0.1278
Strip Curtain for Walk-in Cooler	\$0.0100	\$0.0262
CHW reset 10 deg	\$0.0005	\$0.0037
CHW reset 5 deg	\$0.0005	\$0.0044
EMS	\$0.0400	\$0.1800
Refrigerant charging correction	\$0.0400	\$0.1800
Retrocommissioning, Lighting	\$0.0400	\$0.1433
Optimizing Process Cooling	\$0.0400	\$0.0960
Optimizing Process Heating	\$0.0400	\$0.1078
Compressed Air Optimization	\$0.0400	\$0.0500
AC less than 65,000 1 Ph	\$0.0400	\$0.1800
AC greater than 760,000	\$0.0400	\$0.1800
AC 135,000 - 240,000	\$0.0400	\$0.1800
Air-Cooled Recip Chiller COP = 2.8, IPLV = 3.89	\$0.0400	\$0.1800
Air-Cooled Recip Chiller COP = 3.08, IPLV = 3.76	\$0.0400	\$0.1800
Air-Cooled Recip Chiller COP = 3.36, IPLV = 4.10	\$0.0400	\$0.1800
Air-Cooled Screw Chiller COP = 2.8, IPLV = 3.64	\$0.0400	\$0.1800
Air-Cooled Screw Chiller COP = 3.08, IPLV = 3.80	\$0.0400	\$0.1800
Air-Cooled Screw Chiller COP = 3.36, IPLV = 4.15	\$0.0400	\$0.1800
EMS	\$0.0400	\$0.1800
GSHP under 135,000 17EER	\$0.0400	\$0.1800
GSHP under 135,000 19EER	\$0.0400	\$0.1800
HP under 65,000 1 Ph	\$0.0400	\$0.1800
HP over 240,000	\$0.0400	\$0.1800
HP 135,000 - 240,000	\$0.0400	\$0.1800
Setback-Setup Thermostat	\$0.0100	\$0.1000
Wtr-Cool cent Chiller over 300 ton 0.46 kWperTon with 0.35 kWperTon IPLV	\$0.0400	\$0.1800
Wtr-Cool cent Chiller over 300 ton 0.52 kWperTon with 0.49 kWperTon IPLV	\$0.0400	\$0.1800
Wtr-Cool cent Chiller over 300 ton 0.58 kWperTon with 0.41 kWperTon IPLV	\$0.0400	\$0.1800
Wtr-Cool cent Chiller 150 - 300 ton 0.51 kWperTon with 0.39 kWperTon IPLV	\$0.0400	\$0.1800
Wtr-Cool cent Chiller 150 - 300 ton 0.57 kWperTon with 0.43 kWperTon IPLV	\$0.0400	\$0.1800
Wtr-Cool cent Chiller 150 - 300 ton 0.63 kWperTon with 0.45 kWperTon IPLV	\$0.0400	\$0.1800
Wtr-Cool Centrifugal Chiller under 150 ton 0.56 kWperTon with 0.43 kWperTon IPLV	\$0.0400	\$0.1800
Wtr-Cool Centrifugal Chiller under 150 ton 0.63 kWperTon with 0.48 kWperTon IPLV	\$0.0400	\$0.1800
Wtr-Cool Centrifugal Chiller under 150 ton 0.7 kWperTon with 0.5 kWperTon IPLV	\$0.0400	\$0.1800
Wtr-Cool screw chiller under 150 ton 0.63 kWperTon with 0.44 kWperTon IPLV	\$0.0400	\$0.1800
Wtr-Cool screw chiller under 150 ton 0.71 kWperTon with 0.5 kWperTon IPLV	\$0.0400	\$0.1800
Wtr-Cool screw chiller under 150 ton 0.79 kWperTon with 0.55 kWperTon IPLV	\$0.0400	\$0.1800
Wtr-Cool screw chiller over 300 ton 0.51 kWperTon with 0.36 kWperTon IPLV	\$0.0400	\$0.1800
Wtr-Cool screw chiller over 300 ton 0.58 kWperTon with 0.4 kWperTon IPLV	\$0.0400	\$0.1800
Wtr-Cool screw chiller over 300 ton 0.64 kWperTon with 0.45 kWperTon IPLV	\$0.0400	\$0.1800
Wtr-Cool screw chiller 150 - 300 ton 0.57 kWperTon with 0.4 kWperTon IPLV	\$0.0400	\$0.1800
Wtr-Cool screw chiller 150 - 300 ton 0.65 kWperTon with 0.45 kWperTon IPLV	\$0.0400	\$0.1800
Wtr-Cool screw chiller 150 - 300 ton 0.72 kWperTon with 0.5 kWperTon IPLV	\$0.0400	\$0.1800
WLHP under 17,000	\$0.0400	\$0.1800
WLHP 17,000-65,000	\$0.0400	\$0.1800
WLHP 65,000-135,000	\$0.0400	\$0.1800
Occupancy Sensors under 500 W	\$0.0400	\$0.1800
Occupancy Sensors over 500 W	\$0.0400	\$0.1800
Central Lighting Control	\$0.0400	\$0.1800
Switching Controls for Multilevel Lighting	\$0.0400	\$0.1800
Daylight Sensor controls	\$0.0400	\$0.1800
High Bay 3L T5HO Replacing 250W HID	\$0.0400	\$0.1800
High Bay 6L T5HO Double fixture replace 1000W HID	\$0.0400	\$0.1800
CFL Screw in	\$0.0050	\$0.0149
CFL Screw high wattage	\$0.0020	\$0.0121
CFL Reflector Flood	\$0.0050	\$0.0248
LED Lamps - pre-EISA	\$0.0400	\$0.1800
HP Water Heater 10 to 50 MBH	\$0.0400	\$0.1800
HP Water Heater 50 to 100 MBH	\$0.0400	\$0.1800

HP Water Heater 100 to 300 MBH	\$0.0400	\$0.1773
HP Water Heater 300 to 500 MBH	\$0.0400	\$0.1489
HP Water Heater above 500 MBH	\$0.0400	\$0.1489
ENERGY STAR Commercial Solid Door Freezers less than 15ft3	\$0.0400	\$0.1800
ENERGY STAR Commercial Solid Door Freezers 15 to 30 ft3	\$0.0400	\$0.1800
ENERGY STAR Commercial Solid Door Freezers 30 to 50ft3	\$0.0400	\$0.1800
ENERGY STAR Commercial Solid Door Freezers more than 50ft3	\$0.0400	\$0.1800
ENERGY STAR Commercial Glass Door Refrigerators less than 15ft3	\$0.0400	\$0.1800
ENERGY STAR Commercial Glass Door Refrigerators 15 to 30 ft3	\$0.0400	\$0.1800
ENERGY STAR Commercial Glass Door Freezers less than 15ft3	\$0.0400	\$0.1299
ENERGY STAR Commercial Glass Door Freezers 15 to 30 ft3	\$0.0400	\$0.1800
ENERGY STAR Commercial Glass Door Freezers 30 to 50ft3	\$0.0400	\$0.1800
ENERGY STAR Commercial Glass Door Freezers more than 50ft3	\$0.0400	\$0.1800
ENERGY STAR Ice Machines less than 500 lbs	\$0.0400	\$0.1800
ENERGY STAR Ice Machines 500 to 1000 lbs	\$0.0400	\$0.1800
ENERGY STAR Ice Machines more than 1000 lbs	\$0.0400	\$0.1800
Guest Room Energy Management, Electric Heating	\$0.0400	\$0.1800
Radiant Barrier	\$0.0400	\$0.1800
Window replacement	\$0.0400	\$0.1800
Low Flow Faucet Aerator - Electric water heater	\$0.0058	\$0.0576
Wall Insulation	\$0.0400	\$0.1800
4L T9_NCx	\$0.0400	\$0.1800
6L T8_NCx	\$0.0400	\$0.1800
Built-in fixtures_NCx	\$0.0400	\$0.1800
Dual Technology Sensors_NCx	\$0.0400	\$0.1800
GU-24 pin based CFL_NCx	\$0.0400	\$0.1800
ECM	\$0.0400	\$0.1800
Auto Door Closer	\$0.0400	\$0.1800
Night Covers	\$0.0400	\$0.1800
Desktop Virtualization/Thin Client (2)	\$0.0400	\$0.1800
ENERGY STAR PC (1)	\$0.0400	\$0.1670
PC Power Management Software	\$0.0400	\$0.1000