



*Independent Statistics & Analysis*  
U.S. Energy Information  
Administration

# Capital Cost and Performance Characteristic Estimates for Utility Scale Electric Power Generating Technologies

February 2020



This report was prepared by the U.S. Energy Information Administration (EIA), the statistical and analytical agency within the U.S. Department of Energy. By law, EIA's data, analyses, and forecasts are independent of approval by any other officer or employee of the United States Government. The views in this report therefore should not be construed as representing those of the U.S. Department of Energy or other federal agencies.

## Capital Cost and Performance Characteristic Estimates for Utility Scale Electric Power Generating Technologies

---

To accurately reflect the changing cost of new electric power generators for AEO2020, EIA commissioned Sargent & Lundy (S&L) to evaluate the overnight capital cost and performance characteristics for 25 electric generator types. The following report represents S&L's findings. A separate EIA report, "Addendum: Updated Capital Cost and Performance Characteristic Estimates for Utility Scale Electricity Generating Plants in the Electricity Market Module (EMM) of the National Energy Modeling System (NEMS)," details subsequent updates to the EMM module.

The following report was accepted by EIA in fulfillment of contract number 89303019-CEI00022. All views expressed in this report are solely those of the contractor and acceptance of the report in fulfillment of contractual obligations does not imply agreement with nor endorsement of the findings contained therein. Responsibility for accuracy of the information contained in this report lies with the contractor. Although intended to be used to inform the updating of EIA's EMM module of NEMS, EIA is not obligated to modify any of its models or data in accordance with the findings of this report.



**Sargent & Lundy**

# Capital Cost Study

## Cost and Performance Estimates for New Utility-Scale Electric Power Generating Technologies

**Prepared for**

U.S. Energy Information Administration,  
an agency of the U.S. Department of Energy



*Independent Statistics & Analysis*

U.S. Energy Information  
Administration

**FINAL REPORT | DECEMBER 2019**

Contract No. 89303019CEI00022  
SL-014940 | Project No. 13651.005

### **LEGAL NOTICE**

This report (“Deliverable”) was prepared by Sargent & Lundy, L.L.C. (“Sargent & Lundy”), expressly for the sole use of the U.S. Department of Energy – Energy Information Administration (“Client”) in accordance with the agreement between Sargent & Lundy and the Client. This Deliverable was prepared using the degree of skill and care ordinarily exercised by engineers practicing under similar circumstances. Client acknowledges: (1) Sargent & Lundy prepared this Deliverable subject to the particular scope limitations, budgetary and time constraints, and business objectives of the Client; (2) information and data provided by others may not have been independently verified by Sargent & Lundy; and (3) the information and data contained in this Deliverable are time sensitive and changes in the data, applicable codes, standards, and acceptable engineering practices may invalidate the findings of this Deliverable. Any use or reliance upon this Deliverable by third parties shall be at their sole risk.

---

**Sargent & Lundy** is one of the oldest and most experienced full-service architect engineering firms in the world. Founded in 1891, the firm is a global leader in power and energy with expertise in grid modernization, renewable energy, energy storage, nuclear power, and fossil fuels. Sargent & Lundy delivers comprehensive project services—from consulting, design, and implementation to construction management, commissioning, and operations/maintenance—with an emphasis on quality and safety. The firm serves public and private sector clients in the power and energy, gas distribution, industrial, and government sectors.

---

55 East Monroe Street • Chicago, IL 60603-5780 USA • 312-269-2000



## VERSION LOG

Version	Issue Date
Draft	June 14, 2019
Interim Final Report	August 6, 2019
Final	August 30, 2019
Final – Rev 1.	December 9, 2019



## CONTENT

<b>INTRODUCTION</b> .....	<b>I</b>
Cost & Performance of Technologies .....	I
Cost & Performance Estimates Summary.....	II
<b>BASIS OF ESTIMATES</b> .....	<b>VI</b>
Base Fuel Selection .....	VI
Environmental Compliance Basis.....	VII
Combustion Turbine Capacity Adjustments.....	VII
Capital Cost Estimating .....	VIII
Locational Adjustments .....	X
Environmental Location Factors .....	X
Additional Location Factor Considerations.....	XII
Operating & Maintenance Cost Estimating.....	XII
Fixed O&M.....	XIII
Variable O&M .....	XIII
<b>CASE 1. ULTRA-SUPERCRITICAL COAL WITHOUT CO<sub>2</sub> CAPTURE, 650 MW</b> .....	<b>1-1</b>
1.1 Case Description.....	1-1
1.1.1 Mechanical Equipment & Systems .....	1-3
1.1.2 Electrical & Control Systems.....	1-4
1.1.3 Offsite Requirements.....	1-4
1.2 Capital Cost Estimate .....	1-5
1.3 O&M Cost Estimate .....	1-7
1.4 Environmental & Emissions Information .....	1-8
<b>CASE 2. ULTRA-SUPERCRITICAL COAL WITH 30% CO<sub>2</sub> CAPTURE, 650 MW</b> .....	<b>2-1</b>
2.1 Case Description.....	2-1
2.1.1 Mechanical Equipment & Systems .....	2-1





## CONTENT

2.1.2	Electrical & Control Systems.....	2-4
2.1.3	Offsite Requirements.....	2-4
2.2	Capital Cost Estimate .....	2-5
2.3	O&M Cost Estimate .....	2-7
2.4	Environmental & Emissions Information .....	2-8
<b>CASE 3. ULTRA-SUPERCRITICAL COAL WITH 90% CO<sub>2</sub> CAPTURE, 650 MW .....</b>		<b>3-1</b>
3.1	Case Description.....	3-1
3.1.1	Mechanical Equipment & Systems .....	3-1
3.1.2	Electrical & Control Systems.....	3-4
3.1.3	Offsite Requirements.....	3-4
3.2	Capital Cost Estimate .....	3-5
3.3	O&M Cost Estimate .....	3-7
3.4	Environmental & Emissions Information .....	3-8
<b>CASE 4. INTERNAL COMBUSTION ENGINES, 20 MW .....</b>		<b>4-1</b>
4.1	Case Description.....	4-1
4.1.1	Mechanical Equipment & Systems .....	4-1
4.1.2	Electrical & Control Systems.....	4-1
4.1.3	Offsite Requirements.....	4-2
4.2	Capital Cost Estimate .....	4-2
4.3	O&M Cost Estimate .....	4-4
4.4	Environmental & Emissions Information .....	4-4
<b>CASE 5. COMBUSTION TURBINES AERODERIVATIVE, 100-MW SIMPLE CYCLE....</b>		<b>5-1</b>
5.1	Case Description.....	5-1
5.1.1	Mechanical Equipment & Systems .....	5-1
5.1.2	Electrical & Control Systems.....	5-2
5.1.3	Offsite Requirements.....	5-2



## CONTENT

5.2	Capital Cost Estimate .....	5-2
5.3	O&M Cost Estimate .....	5-4
5.4	Environmental & Emissions Information .....	5-5
<b>CASE 6. COMBUSTION TURBINE F CLASS, 240-MW SIMPLE CYCLE.....</b>		<b>6-1</b>
6.1	Case Description.....	6-1
6.1.1	Mechanical Equipment & Systems .....	6-1
6.1.2	Electrical & Control Systems.....	6-2
6.1.3	Offsite Requirements.....	6-2
6.2	Capital Cost Estimate .....	6-2
6.3	O&M Cost Estimate .....	6-4
6.4	Environmental & Emissions Information .....	6-5
<b>CASE 7. COMBUSTION TURBINE H CLASS, 1100-MW COMBINED CYCLE.....</b>		<b>7-1</b>
7.1	Case Description.....	7-1
7.1.1	Mechanical Equipment & Systems .....	7-1
7.1.2	Electrical & Control Systems.....	7-3
7.1.3	Offsite Requirements.....	7-3
7.2	Capital Cost Estimate .....	7-3
7.3	O&M Cost Estimate .....	7-5
7.4	Environmental & Emissions Information .....	7-6
<b>CASE 8. COMBUSTION TURBINE H CLASS, COMBINED-CYCLE SINGLE SHAFT, 430 MW 8-1</b>		
8.1	Case Description.....	8-1
8.1.1	Mechanical Equipment & Systems .....	8-1
8.1.2	Electrical & Control Systems.....	8-4
8.1.3	Offsite Requirements.....	8-4
8.2	Capital Cost Estimate .....	8-5



## CONTENT

8.3	O&M Cost Estimate .....	8-6
8.4	Environmental & Emissions Information .....	8-7
<b>CASE 9. COMBUSTION TURBINE H CLASS, COMBINED-CYCLE SINGLE SHAFT WITH 90% CO<sub>2</sub> CAPTURE, 430 MW .....</b>		<b>9-1</b>
9.1	Case Description.....	9-1
9.1.1	Mechanical Equipment & Systems .....	9-1
9.1.2	Electrical & Control Systems.....	9-2
9.1.3	Offsite Requirements.....	9-3
9.2	Capital Cost Estimate .....	9-3
9.3	O&M Cost Estimate .....	9-5
9.4	Environmental & Emissions Information .....	9-6
<b>CASE 10. FUEL CELL, 10 MW .....</b>		<b>10-1</b>
10.1	Case Description.....	10-1
10.1.1	Chemical Operation.....	10-1
10.1.2	Mechanical Equipment & Systems .....	10-2
10.1.3	Offsite Requirements.....	10-3
10.2	Capital Cost Estimate .....	10-3
10.3	O&M Cost Estimate .....	10-5
10.4	Environmental & Emissions Information .....	10-5
<b>CASE 11. ADVANCED NUCLEAR, 2156 MW.....</b>		<b>11-1</b>
11.1	Case Description.....	11-1
11.1.1	Mechanical Equipment & Systems .....	11-1
11.1.2	Electrical & Control Systems.....	11-1
11.1.3	Offsite Requirements.....	11-2
11.2	Capital Cost Estimate .....	11-2
11.3	O&M Cost Estimate .....	11-3



## CONTENT

11.4	Environmental & Emissions Information .....	11-4
<b>CASE 12. SMALL MODULAR REACTOR NUCLEAR POWER PLANT, 600 MW .....</b>		<b>12-1</b>
12.1	Case Description.....	12-1
12.1.1	Mechanical Equipment and Systems.....	12-1
12.1.2	Electrical and Control Systems .....	12-2
12.1.3	Offsite Requirements.....	12-2
12.2	Capital Cost Estimate .....	12-2
12.3	O&M Cost Estimate .....	12-4
12.4	Environmental & Emissions Information .....	12-4
<b>CASE 13. BIOMASS PLANT, 50 MW.....</b>		<b>13-1</b>
13.1	Case Description.....	13-1
13.1.1	Mechanical Equipment & Systems .....	13-1
13.1.2	Electrical & Control Systems.....	13-4
13.1.3	Offsite Requirements.....	13-4
13.2	Capital Cost Estimate .....	13-4
13.3	O&M Cost Estimate .....	13-6
13.4	Environmental & Emissions Information .....	13-7
<b>CASE 14. 10% BIOMASS CO-FIRE RETROFIT .....</b>		<b>14-1</b>
14.1	Case Description.....	14-1
14.1.1	Mechanical Equipment & Systems .....	14-1
14.1.2	Electrical & Control Systems.....	14-2
14.1.3	Offsite Requirements.....	14-2
14.2	Capital Cost Estimate .....	14-3
14.3	O&M Cost Estimate .....	14-4
14.4	Environmental & Emissions Information .....	14-5



## CONTENT

<b>CASE 15. GEOTHERMAL PLANT, 50 MW .....</b>	<b>15-1</b>
15.1 Case Description.....	15-1
15.1.1 Mechanical Equipment & Systems .....	15-2
15.1.2 Electrical & Control Systems.....	15-4
15.1.3 Offsite Requirements.....	15-4
15.2 Capital Cost Estimate .....	15-4
15.3 O&M Cost Estimate .....	15-6
15.4 Environmental & Emissions Information .....	15-6
<b>CASE 16. INTERNAL COMBUSTION ENGINES, LANDFILL GAS, 30 MW .....</b>	<b>16-1</b>
16.1 Case Description.....	16-1
16.1.1 Mechanical Equipment and Systems.....	16-1
16.1.2 Electrical and Control Systems .....	16-1
16.1.3 Offsite Requirements.....	16-2
16.2 Capital Cost Estimate .....	16-2
16.3 O&M Cost Estimate .....	16-3
16.4 Environmental & Emissions Information .....	16-4
<b>CASE 17. HYDROELECTRIC PLANT, 100 MW .....</b>	<b>17-1</b>
17.1 Case Description.....	17-1
17.1.1 Offsite Requirements.....	17-3
17.2 Capital Cost Estimate .....	17-3
17.3 O&M Cost Estimate .....	17-4
17.4 Environmental & Emissions Information .....	17-4
<b>CASE 18. BATTERY ENERGY STORAGE SYSTEM, 50 MW / 200 MWH .....</b>	<b>18-1</b>
18.1 Case Description.....	18-1
18.1.1 Offsite Requirements.....	18-4



## CONTENT

18.2	Capital Cost Estimate .....	18-4
18.3	O&M Cost Estimate .....	18-6
18.4	Environmental & Emissions Information .....	18-7
<b>CASE 19. BATTERY ENERGY STORAGE SYSTEM, 50 MW / 100 MWH .....</b>		<b>19-1</b>
19.1	Case Description.....	19-1
19.1.1	Offsite Requirements.....	19-1
19.2	Capital Cost Estimate .....	19-1
19.3	O&M Cost Estimate .....	19-3
19.4	Environmental & Emissions Information .....	19-4
<b>CASE 20. ONSHORE WIND, LARGE PLANT FOOTPRINT, 200 MW .....</b>		<b>20-1</b>
20.1	Case Description.....	20-1
20.2	Mechanical Equipment & Systems .....	20-1
20.2.1	Electrical & Control Systems.....	20-2
20.2.2	Offsite Requirements.....	20-2
20.3	Capital Cost Estimate .....	20-3
20.4	O&M Cost Estimate .....	20-4
20.5	Environmental & Emissions Information .....	20-5
<b>CASE 21. ONSHORE WIND, SMALL PLANT FOOTPRINT, 50 MW.....</b>		<b>21-1</b>
21.1	Case Description.....	21-1
21.1.1	Mechanical Equipment & Systems .....	21-1
21.1.2	Electrical & Control Systems.....	21-2
21.1.3	Offsite Requirements.....	21-2
21.2	Capital Cost Estimate .....	21-3
21.3	O&M Cost Estimate .....	21-4
21.4	Environmental & Emissions Information .....	21-5



## CONTENT

<b>CASE 22. OFFSHORE WIND, 400 MW.....</b>	<b>22-1</b>
22.1 Case Description.....	22-1
22.1.1 Mechanical Equipment & Systems .....	22-1
22.1.2 Electrical & Control Systems.....	22-1
22.1.3 Offsite Requirements.....	22-2
22.2 Capital Cost Estimate .....	22-2
22.3 O&M Cost Estimate .....	22-3
22.4 Environmental & Emissions Information .....	22-4
<b>CASE 23. CONCENTRATING SOLAR PLANT, 100 MW, 8-HR STORAGE.....</b>	<b>23-1</b>
23.1 Case Description.....	23-1
23.1.1 Offsite Requirements.....	23-4
23.2 Capital Cost Estimate .....	23-4
23.3 O&M Cost Estimate .....	23-6
23.4 Environmental & Emissions Information .....	23-7
<b>CASE 24. SOLAR PHOTOVOLTAIC, 150 MW<sub>AC</sub>.....</b>	<b>24-1</b>
24.1 Case Description.....	24-1
24.1.1 Mechanical Equipment & Systems .....	24-1
24.1.2 Electrical & Control Systems.....	24-3
24.1.3 Offsite Requirements.....	24-3
24.2 Capital Cost Estimate .....	24-4
24.3 O&M Cost Estimate .....	24-5
24.4 Environmental & Emissions Information .....	24-6
<b>CASE 25. SOLAR PHOTOVOLTAIC WITH BATTERY ENERGY STORAGE SYSTEM, 150 MW<sub>AC</sub> .....</b>	<b>25-1</b>
25.1 Case Description.....	25-1
25.1.1 Mechanical Equipment & Systems .....	25-1



---

## CONTENT

25.1.2 Electrical & Control Systems.....	25-2
25.1.3 Offsite Requirements.....	25-2
25.2 Capital Cost Estimate .....	25-3
25.3 O&M Cost Estimate .....	25-4
25.4 Environmental & Emissions Information .....	25-5





---

## APPENDIXES

Appendix A. Labor Location-Based Cost Adjustments

Appendix B. Combustion Turbine Capacity Adjustments



## TABLES AND FIGURES

<u>Table or Figure</u>	<u>Page</u>
Table 1 — List of Reference Technologies.....	I
Table 2 — Cost & Performance Summary Table.....	III
Table 3 — Reference Coal Specification.....	VI
Table 4 — Reference Natural Gas Specification .....	VI
Table 5 — Reference Wood Biomass Specification .....	VII
Table 1-1 — Case 1 Capital Cost Estimate .....	1-6
Table 1-2 — Case 1 O&M Cost Estimate.....	1-8
Table 1-3 — Case 1 Emissions.....	1-8
Table 2-1 — Case 2 Capital Cost Estimate .....	2-6
Table 2-2 — Case 2 O&M Cost Estimate.....	2-8
Table 2-3 — Case 2 Emissions.....	2-9
Table 3-1 — Case 3 Capital Cost Estimate.....	3-6
Table 3-2 — Case 3 O&M Cost Estimate.....	3-8
Table 3-3 — Case 3 Emissions.....	3-8
Table 4-1 — Case 4 Capital Cost Estimate .....	4-2
Table 4-2 — Case 4 O&M Cost Estimate.....	4-4
Table 4-3 — Case 4 Emissions.....	4-4
Table 5-1 — Case 5 Capital Cost Estimate.....	5-3
Table 5-2 — Case 5 O&M Cost Estimate .....	5-5
Table 5-3 — Case 5 Emissions.....	5-5
Table 6-1 — Case 6 Capital Cost Estimate .....	6-3
Table 6-2 — Case 6 O&M Cost Estimate.....	6-5
Table 6-3 — Case 6 Emissions.....	6-5
Table 7-1 — Case 7 Capital Cost Estimate.....	7-4
Table 7-2 — Case 7 O&M Cost Estimate .....	7-6
Table 7-3 — Case 7 Emissions .....	7-6
Table 8-1 — Case 8 Capital Cost Estimate .....	8-5
Table 8-2 — Case 8 O&M Cost Estimate.....	8-7
Table 8-3 — Case 8 Emissions .....	8-7
Table 9-1 — Case 9 Capital Cost Estimate .....	9-4
Table 9-2 — Case 9 O&M Cost Estimate.....	9-6



## TABLES AND FIGURES

<u>Table or Figure</u>	<u>Page</u>
Table 9-3 — Case 9 Emissions.....	9-6
Table 10-1 — Fuel Cell Chemical Reactions.....	10-2
Table 10-2 — Case 10 Capital Cost Estimate .....	10-4
Table 10-3 — Case 10 O&M Cost Estimate .....	10-5
Table 10-4 — Case 10 Emissions .....	10-6
Table 11-1 — Case 11 Capital Cost Estimate .....	11-2
Table 11-2 — Case 11 O&M Cost Estimate.....	11-4
Table 12-1 — Case 12 Capital Cost Estimate .....	12-2
Table 12-2 — Case 12 O&M Cost Estimate.....	12-4
Table 13-1 — Case 13 Capital Cost Estimate .....	13-5
Table 13-2 — Case 13 O&M Cost Estimate.....	13-7
Table 13-3 — Case 13 Emissions .....	13-7
Table 14-1 — Case 14 Capital Cost Estimate .....	14-3
Table 14-2 — Case 14 O&M Cost Estimate.....	14-4
Table 14-3 — Case 14 Emissions .....	14-5
Table 15-1 — Case 15 Capital Cost Estimate.....	15-5
Table 15-2 — Case 15 O&M Cost Estimate.....	15-6
Table 16-1 — Case 16 Capital Cost Estimate .....	16-2
Table 16-2 — Case 16 O&M Cost Estimate.....	16-4
Table 16-3 — Case 16 Emissions .....	16-4
Table 17-1 — Case 17 Capital Cost Estimate.....	17-3
Table 17-2 — Case 17 O&M Cost Estimate .....	17-4
Table 18-1 — Case 18 Capital Cost Estimate .....	18-4
Table 18-2 — Case 18 O&M Cost Estimate .....	18-7
Table 19-1 — Case 19 Capital Cost Estimate .....	19-2
Table 19-2 — Case 19 O&M Cost Estimate.....	19-4
Table 20-1 — Case 20 Capital Cost Estimate.....	20-3
Table 20-2 — Case 20 O&M Cost Estimate .....	20-5
Table 21-1 — Case 21 Capital Cost Estimate .....	21-3
Table 21-2 — Case 21 O&M Cost Estimate.....	21-5
Table 22-1 — Case 22 Capital Cost Estimate .....	22-3



## TABLES AND FIGURES

<u>Table or Figure</u>	<u>Page</u>
Table 22-2 — Case 22 O&M Cost Estimate.....	22-4
Table 23-1 — Case 23 Capital Cost Estimate .....	23-5
Table 23-2 — Case 23 O&M Cost Estimate.....	23-7
Table 24-1 — Case 24 Capital Cost Estimate .....	24-4
Table 24-2 — Case 24 O&M Cost Estimate.....	24-6
Table 25-1 — Case 25 Capital Cost Estimate.....	25-3
Table 25-2 — Case 25 O&M Cost Estimate .....	25-5
Figure 1-1 — USC Coal Boiler – Flow Diagram.....	1-2
Figure 2-1 — Carbon Capture Flow Diagram.....	2-3
Figure 5-1 — Case 2 Configuration.....	5-1
Figure 6-1 — Case 6 Configuration .....	6-1
Figure 7-1 — Case 7 Configuration .....	7-2
Figure 8-1 — Case 8 Configuration – Process Diagram .....	8-3
Figure 8-2 — Case 8 Configuration – Simplified Sketch.....	8-4
Figure 10-1 — Simplified Solid Oxide Fuel Cell.....	10-2
Figure 10-2 — Typical Solid Oxide Fuel Cell Project.....	10-3
Figure 13-1 — Typical BFB Biomass Boiler Arrangement.....	13-3
Figure 14-1 — Biomass Cofiring in Coal-Fired Boilers, Separate Feed Arrangement.....	14-2
Figure 15-1 — Geothermal Binary Cycle Power Plant .....	15-3
Figure 17-1 — Storage-Type Hydroelectric Power Plant .....	17-1
Figure 17-2 — Dam and Spillway of Hydroelectric Power Plant.....	17-2
Figure 17-3 — Typical Hydroelectric Power Turbine Hall .....	17-2
Figure 18-1 — Utility-Scale Lithium-Ion Batteries.....	18-2
Figure 18-2 — BESS Flow Diagram.....	18-2
Figure 18-3 — Typical Battery Storage Container .....	18-3
Figure 20-1 — Wind Turbine Generator Drivetrain.....	20-2
Figure 21-1 — Wind Turbine Generator Drivetrain.....	21-2
Figure 23-1 — Concentrating Solar Power Tower System Diagram .....	23-2
Figure 23-2 — Aerial View of Concentrating Solar Power Tower Project .....	23-3
Figure 23-3 — United States Solar Resource.....	23-4



---

## TABLES AND FIGURES

<u>Table or Figure</u>	<u>Page</u>
Figure 24-1 — Solar Photovoltaic Project .....	24-1
Figure 24-2 — Single-Axis Tracking .....	24-2
Figure 25-1 — AC Coupled Solar PV and Battery Storage .....	25-2



## ACRONYMS AND ABBREVIATIONS

<b>Term</b>	<b>Definition or Clarification</b>
°F	degrees Fahrenheit
AC	alternating current
ACC	air-cooled condenser
BESS	battery energy storage system
BFB	bubbling fluidized bed
BOP	balance of plant
Btu/kWh	British thermal unit(s) per kilowatt hour
CC	combined cycle
CCS	carbon capture and sequestration
CO	carbon monoxide
CO <sub>2</sub>	carbon dioxide
CSP	Concentrating Solar Power
CT	combustion turbine
DC	direct current
DCS	distributed control system
EIA	U.S. Energy Information Administration
EOH	equivalent operating hours
EPC	engineering, procurement, and construction
FGD	flue gas desulfurization
G&A	general and administrative costs
GSU	generator step-up transformer
HHV	higher heating value
HRSG	heat recovery steam generator



## ACRONYMS AND ABBREVIATIONS

<b>Term</b>	<b>Definition or Clarification</b>
Hz	hertz
kV	kilovolt(s)
kW	kilowatt(s)
kWh	kilowatt hour(s)
lb/MMBtu	pound(s) per one million British thermal units
LNB	low-NO <sub>x</sub> burner
MVA	megavolt ampere
MW	megawatt(s)
MWh	megawatt hour(s)
NO <sub>x</sub>	nitrogen oxide
O&M	operations and maintenance
OEM	original equipment manufacturer
OFA	overfire air
psia	pounds per square inch absolute
PV	photovoltaic
RICE	reciprocating internal combustion engine
SCADA	Supervisory Control and Data Acquisition
SCR	selective catalytic reduction
SMR	small modular reactor
SO <sub>2</sub>	sulfur dioxide
STG	steam turbine generator
USC	ultra-supercritical
V	volt



---

## ACRONYMS AND ABBREVIATIONS

<b>Term</b>	<b>Definition or Clarification</b>
WFGD	wet flue gas desulfurization
WTG	wind turbine generator
ZLD	zero liquid discharge





# Introduction



## INTRODUCTION

The U.S. Energy Information Administration (EIA) retained Sargent & Lundy to conduct a study of the cost and performance of new utility-scale electric power generating technologies. This report contains our cost and performance estimates for 25 different reference technology cases. The EIA will use these estimates to improve the EIA's Electricity Market Module's ability to represent the changing landscape of electricity generation and thus better represent capital and non-fuel operating costs of generating technologies being installed or under consideration for capacity expansion. The Electricity Market Module is a submodule within the EIA's National Energy Modeling System, a computer-based energy supply modeling system used for the EIA's *Annual Energy Outlook* and other analyses.

Sargent & Lundy developed the characteristics of the power generating technologies in this study based on information about similar facilities recently built or under development in the United States and abroad. Developing the characteristics of each generating technology included the specification of representative plant sizes, configurations, major equipment, and emission controls. Sargent & Lundy's cost assessment included the estimation of overnight capital costs, construction lead times, and contingencies as well as fixed and variable operating costs. We also estimated the net plant capacity, net plant heat rates, and controlled emission rates for each technology studied. We performed our assessments with consistent estimating methodologies across all generating technologies.

## COST & PERFORMANCE OF TECHNOLOGIES

The following table lists all the power generating technologies we assessed in this study.

**Table 1 — List of Reference Technologies**

Case No.	Technology	Description
1	650 MW Net, Ultra-Supercritical Coal w/o Carbon Capture – Greenfield	1 x 735 MW Gross
2	650 MW Net, Ultra-Supercritical Coal 30% Carbon Capture	1 x 769 MW Gross
3	650 MW Net, Ultra-Supercritical Coal 90% Carbon Capture	1 x 831 MW Gross
4	Internal Combustion Engines	4 x 5.6 MW
5	Combustion Turbines – Simple Cycle	2 x LM6000
6	Combustion Turbines – Simple Cycle	1 x GE 7FA
7	Combined-Cycle 2x2x1	GE 7HA.02
8	Combined-Cycle 1x1x1, Single Shaft	H Class
9	Combined-Cycle 1x1x1, Single Shaft, w/ 90% Carbon Capture	H-Class
10	Fuel Cell	34 x 300 kW Gross



Case No.	Technology	Description
11	Advanced Nuclear (Brownfield)	2 x AP1000
12	Small Modular Reactor Nuclear Power Plant	12 x 50-MW Small Modular Reactor
13	50-MW Biomass Plant	Bubbling Fluidized Bed
14	10% Biomass Co-Fire Retrofit	300-MW PC Boiler
15	Geothermal	Binary Cycle
16	Internal Combustion Engines – Landfill Gas	4 x 9.1 MW
17	Hydroelectric Power Plant	New Stream Reach Development
18	Battery Energy Storage System	50 MW   200 MWh
19	Battery Energy Storage System	50 MW   100 MWh
20	Onshore Wind – Large Plant Footprint: Great Plains Region	200 MW   2.8 MW WTG
21	Onshore Wind – Small Plant Footprint: Coastal Region	50 MW   2.8 MW WTG
22	Fixed-bottom Offshore Wind: Monopile Foundations	400 MW   10 MW WTG
23	Concentrating Solar Power Tower	with Molten Salt Thermal Storage
24	Solar PV w/ Single Axis Tracking	150 MW <sub>AC</sub>
25	Solar PV w/ Single Axis Tracking + Battery Storage	150 MW <sub>AC</sub> Solar 50 MW   200 MWh Storage

**Acronym Definitions:**

- BESS = battery energy storage system
- Btu/kWh = British thermal units per kilowatt hour
- CC = combined cycle
- CCS = carbon capture and sequestration
- CT = combustion turbine
- kW = kilowatt
- MW = megawatt
- MW<sub>AC</sub> = megawatt alternating current
- MWh = megawatt hour
- PV = photovoltaic
- USC = ultra-supercritical
- WTG = wind turbine generator

As part of the technology assessment, Sargent & Lundy reviewed recent market trends for the reference technologies using publicly available sources and in-house data. We also used our extensive background in power plant design and experience in performing similar cost and performance assessments. Using a combination of public and internal information sources, Sargent & Lundy identified the representative costs and performance for the reference technologies.

## COST & PERFORMANCE ESTIMATES SUMMARY

Table 2 summarizes all technologies examined, including overnight capital cost information, fixed operating and maintenance (O&M) costs, and variable non-fuel O&M costs as well as emissions estimates for new installations (in pounds per one million British thermal units [lb/MMBtu]).



Table 2 — Cost &amp; Performance Summary Table

Case No.	Technology	Description	Net Nominal Capacity (kW)	Net Nominal Heat Rate (Btu/Kwh)	Capital Cost (\$/kW)	Fixed O&M Cost (\$/kW-year)	Variable O&M Cost (\$/MWh)	NOx (lb/MMBtu)	SO2 (lb/MMBtu)	CO2 (lb/MMBtu)
1	650 MW Net, Ultra-Supercritical Coal w/o Carbon Capture – Greenfield	1 x 735 MW Gross	650	8638	3676	40.58	4.50	0.06	0.09	206
2	650 MW Net, Ultra-Supercritical Coal 30% Carbon Capture	1 x 769 MW Gross	650	9751	4558	54.30	7.08	0.06	0.09	144
3	650 MW Net, Ultra-Supercritical Coal 90% Carbon Capture	1 x 831 MW Gross	650	12507	5876	59.54	10.98	0.06	0.09	20.6
4	Internal Combustion Engines	4 x 5.6 MW	21	8295	1810	35.16	5.69	0.02	0	117
5	Combustion Turbines – Simple Cycle	2 x LM6000	105	9124	1175	16.30	4.7	0.09	0.00	117
6	Combustion Turbines – Simple Cycle	1 x GE 7FA	237	9905	713	7.00	4.5	0.03	0.00	117
7	Combined-Cycle 2x2x1	GE 7HA.02	1083	6370	958	12.20	1.87	0.0075	0.00	117
8	Combined-Cycle 1x1x1, Single Shaft	H Class	418	6431	1084	14.1	2.55	0.0075	0.00	117
9	Combined-Cycle 1x1x1, Single Shaft, w/ 90% Carbon Capture	H-Class	377	7124	2481	27.6	5.84	0.0075	0.00	11.7
10	Fuel Cell	34 x 300 kW Gross	10	6469	6700	30.78	0.59	0.0002	0	117
11	Advanced Nuclear (Brownfield)	2 x AP1000	2156	10608	6041	121.64	2.37	0	0	0
12	Small Modular Reactor Nuclear Power Plant	12 x 50-MW Small Modular Reactor	600	10046	6191	95.00	3.00	0	0	0
13	50-MW Biomass Plant	Bubbling Fluidized Bed	50	13300	4097	125.72	4.83	0.08	<0.03	206
14	10% Biomass Co-Fire Retrofit	300-MW PC Boiler	30	+ 1.5%	705	25.57	1.90	0%–20%	-8%	-8%
15	Geothermal	Binary Cycle	50	N/A	2521	128.544	1.16	0	0	0



Case No.	Technology	Description	Net Nominal Capacity (kW)	Net Nominal Heat Rate (Btu/kWh)	Capital Cost (\$/kW)	Fixed O&M Cost (\$/kW-year)	Variable O&M Cost (\$/MWh)	NOx (lb/MMBtu)	SO2 (lb/MMBtu)	CO2 (lb/MMBtu)
16	Internal Combustion Engines – Landfill Gas	4 x 9.1 MW	35.6	8513	1563	20.1	6.2	0.02	0	117
17	Hydroelectric Power Plant	New Stream Reach Development	100	N/A	5316	29.86	0	0	0	0
18	Battery Energy Storage System	50 MW   200 MWh	50	N/A	1389 (347 \$/kWh)	24.8	0	0	0	0
19	Battery Energy Storage System	50 MW   100 MWh	50	N/A	845 (423 \$/kWh)	12.9	0	0	0	0
20	Onshore Wind – Large Plant Footprint: Great Plains Region	200 MW   2.82 MW WTG	200	N/A	1265	26.34	0	0	0	0
21	Onshore Wind – Small Plant Footprint: Coastal Region	50 MW   2.78 MW WTG	50	N/A	1677	35.14	0	0	0	0
22	Fixed-bottom Offshore Wind: Monopile Foundations	400 MW   10 MW WTG	400	N/A	4375	110	0	0	0	0
23	Concentrating Solar Power Tower	with Molten Salt Thermal Storage	115	N/A	7221	85.4	0	0	0	0
24	Solar PV w/ Single Axis Tracking	150 MW <sub>AC</sub>	150	N/A	1313	15.25	0	0	0	0
25	Solar PV w/ Single Axis Tracking + Battery Storage	150 MW <sub>AC</sub> Solar 50 MW   200 MWh Storage	150	N/A	1755	31.27	0	0	0	0

**Acronym Definitions:**

- \$/kW = dollar(s) per kilowatt
- \$/kW-year = dollar(s) per kilowatt year
- \$/MWh = dollar(s) per megawatt hour
- BESS = battery energy storage system
- Btu/kWh = British thermal units per kilowatt hour
- CC = combined cycle
- CCS = carbon capture and sequestration
- CO<sub>2</sub> = carbon dioxide
- CT = combustion turbine
- kW = kilowatt
- lb/MMBtu = pound(s) per million British thermal units
- MW = megawatt
- MW<sub>AC</sub> = megawatt alternating current
- MWh = megawatt hour
- PV = photovoltaic
- USC = ultra-supercritical
- WTG = wind turbine generator



# Basis of Estimates



## BASIS OF ESTIMATES

### BASE FUEL SELECTION

We used the following fuel specifications as a basis for the cost estimates. The tables shown below represent typical fuel specifications for coal, natural gas, and wood biomass.

**Table 3 — Reference Coal Specification**

Rank	Bituminous
<b>Proximate Analysis (weight %)</b>	
<b>Fuel Parameter</b>	As Received
Moisture	11.2
Ash	9.7
Carbon	63.75
Oxygen	6.88
Hydrogen	4.5
Sulfur	2.51
Nitrogen	1.25
Chlorine	0.29
HHV, Btu/lb	11,631
Fixed Carbon/Volatile Matter	1.2

HHV = higher heating value | Btu/lb = British thermal unit per pound

**Table 4 — Reference Natural Gas Specification**

Component		Volume Percentage
Methane	CH <sub>4</sub>	93.9
Ethane	C <sub>2</sub> H <sub>6</sub>	3.2
Propane	C <sub>3</sub> H <sub>8</sub>	0.7
n-Butane	C <sub>4</sub> H <sub>10</sub>	0.4
Carbon Dioxide	CO <sub>2</sub>	1
Nitrogen	N <sub>2</sub>	0.8
Total		100
		<b>LHV</b> <b>HHV</b>
Btu/lb		20,552      22,793
Btu/scf		939      1,040

Btu/scf = British thermal unit per standard cubic foot



**Table 5 — Reference Wood Biomass Specification**

Type	Woodchips
Component	Weight %
Moisture	20– 50
Ash	0.1–0.7
Carbon	32
Sulfur	0.01
Oxygen	28
Hydrogen	3.8
Nitrogen	0.1–0.3
HHV, Btu/lb	5,400–6,200

## ENVIRONMENTAL COMPLIANCE BASIS

Our technology assessments selected include the best available (emissions) control technology for sulfur dioxide (SO<sub>2</sub>), nitrogen oxide (NO<sub>x</sub>), particulate matter, mercury, and CO<sub>2</sub>, where applicable. Best available control technology guidelines are covered by the U.S. Clean Air Act Title 1, which promotes air quality, ozone protection, and emission limitations. The level of emission controls is based on the following best available control technology guidelines:

- Total source emissions
- Regional environmental impact
- Energy consumption
- Economic costs

Best available control technology is not the most restrictive pollution control standard since it still includes a cost-benefit analysis for technology use. Specific technologies chosen for estimation are further described in their respective cases.

## COMBUSTION TURBINE CAPACITY ADJUSTMENTS

Appendix B includes combustion turbine capacity adjustments.





Adjustments for local ambient conditions were made for power plants using combustion turbines (CTs). Since CTs produce power proportional to mass flow and ambient air temperature, relative humidity, and elevation affect air density, these conditions also affect CT performance:

- Temperature affects air density in an inversely proportional relationship and effects combined-cycle (CC) plants' cooling systems, which impacts overall plant performance.
- Relative humidity affects air density in a proportional relationship. For plants with wet cooling (evaporative coolers, wet cooling towers, etc.), relative humidity and temperature determine the effectiveness of that equipment, with the highest effectiveness when the temperature is high and the relative humidity low.
- Elevation affects air pressure and density in an inversely proportional relationship, and it was calculated in this study by using elevation above sea level. This gives the average impact of air pressure on performance, ignoring the short-term effects of weather.

Temperatures and relative humidity used in this adjustment table are based on annual averages for the locations specified. An adjustment factor for the various technologies were compared across locations on a consistent basis.

## **CAPITAL COST ESTIMATING**

Sargent & Lundy has used a top-down capital cost estimating methodology derived from parametric evaluations of costs from actual or planned projects with similar scope and configurations to the generating technology considered. We have used both publicly available information and internal sources from which to establish the cost parameters. In some cases, we have use used portions of more detailed cost estimates to adjust the parametric factors.

The capital cost estimates represent a complete power plant facility on a generic site at a non-specific U.S. location. As applicable, the basis of the capital costs is defined as all costs to engineer, procure, construct, and commission all equipment within the plant facility fence line. As described in the following section, we have also estimated location adjustments to help establish the cost impacts to project implementation in more specific areas or regions within the United States. Capital costs account for all costs incurred during construction of the power plant before the commercial online date. The capital costs are divided between engineering, procurement, and construction (EPC) contractor and owner's costs. Sargent & Lundy assumes that the power plant developer or owner will hire an EPC contractor for turnkey construction of the project. Unless noted otherwise, the estimates assume that the EPC contractor cost will include procurement of equipment, materials, and all construction labor



associated with the project. The capital costs provided are overnight capital costs in 2019 price levels. Overnight capital costs represent the total cost a developer would expect to incur during the construction of a project, excluding financing costs. The capital cost breakdowns for the EPC contractor are as follows:

- The civil and structural material and installation cost includes all material and associated labor for civil and structural tasks. This includes both labor and material for site preparation, foundation, piling, structural steel, and buildings.
- The mechanical equipment supply and installation cost includes all mechanical equipment and associated labor for mechanical tasks. This includes both labor and material for equipment installation such as pumps and tanks, piping, valves, and piping specialties.
- The electrical and instrumentation and controls supply and installation includes all costs for transformers, switchgear, control systems, wiring, instrumentation, and raceway.
- The project indirect costs include engineering, construction management, and start-up and commissioning. The fees include contractor overhead costs, fees, and profit.

The owner's costs primarily consist of costs incurred to develop the project as well as land and utility interconnection costs. The owner's development costs include project development, studies, permitting, legal, owner's project management, owner's engineering, and owner's participation in startup and commissioning. Outside-the-fence-line costs are considered as owner's costs. These include electrical interconnection costs and natural gas interconnection and metering costs; however, these costs too are generic and based on nominal distances to substations and gas pipeline laterals. We have also assumed that no substation upgrades would be required for the electrical interconnection. Transmission costs are based on a one-mile transmission line (unless otherwise stated) with voltage ranging from 230 kilovolts (kV) to 500 kV depending on the unit capacity. Land requirements are based on typical land requirements for each technology with per-acreage costs based on a survey of typical site costs across the United States.

The overall project contingency is also included to account for undefined project scope and pricing uncertainty for both capital cost components and owner's cost components. The levels of contingency differ in some of the estimates based on the nature of the technology and the complexity of the technology implementation.



## Locational Adjustments

We estimated the capital costs adjustment factors account for technology implementation at various U.S. locations. Appendix A provides locational adjustment factors.

Craft labor rates for each location were developed from the publication *RS Means Labor Rates for the Construction Industry*, 2019 edition. Costs were added to cover social security, workmen's compensation, and federal and state unemployment insurance. The resulting burdened craft rates were used to develop typical crew rates applicable to the task performed. For each technology, up to 26 different crews were used to determine the average wage rate for each location. For several technologies, relevant internal Sargent & Lundy estimates were used to further refine the average wage rate by using the weighted average based on the crew composition for the specific technology.

Sargent & Lundy used a "30 City Average" based on *RS Means Labor Rates for the Construction Industry* to establish the base location for all the technologies. We measured the wage rate factor for each location against the base rate (the "30 City Average"). The location factors were then improved by adding the regional labor productivity factor; these factors are based on the publication *Compass International Global Construction Costs Yearbook*, 2018 edition. Even though *Compass International Global Construction Costs Yearbook* provides productivity factors for some of the major metro areas in the United States, the productivity factors on the state level were mostly used to represent the typical construction locations of plants for each of the technologies. The final location factor was measured against average productivity factor, which is based on the same 30 cities that are included in the "30 City Average" wage rate.

## Environmental Location Factors

Capital cost adjustment factors have also been estimated to account for environmental conditions at various U.S. locations. These environmental location factors, however, do not account for any state or local jurisdictional amendments or requirements that modify the national design codes and standards (i.e., American Society of Civil Engineers, International Building Code. Soil Site Class D for stiff soils was assumed; geotechnical investigation is required to account for site-specific soil conditions that will need to be considered during detailed design. Risk Category II was assumed for all power generating technologies. Each environmental factor was baselined, and the geometric mean was used to determine the combined environmental location factor that accounts for the wind, seismic, snow, and tsunami effects as applicable. To distribute the environmental location factor to the material costs for the civil, mechanical, electrical, carbon capture, and other works for each of the 25 cases, the factor was



proportioned based on the assumed effect environmental loading would have on the works. In other words, the concrete foundations support most of the design loading; therefore, the percentage of the environmental loading factor that was distributed to the civil works was typically the highest. The distribution of the environmental loading factor was based on typical general arrangements (i.e., equipment, buildings) for each of the 25 cases.

The environmental location factor for wind is based on ASCE 7-16, and it is based on velocity pressure for enclosed, rigid buildings with flat roofs, which is the most widely used building configuration at power generating stations. The baseline was the approximate average velocity pressure for the location data set; therefore, the factor was reduced for locations lower than the average and increased for locations above the average.

The environmental location factor for seismic is based on the Seismic Design Category, which is determined based on site-specific coefficients<sup>1</sup> and the calculated Mapped Spectral Response or Design Spectral Acceleration. The baseline was Seismic Design Category B; therefore, the factor was reduced for Seismic Design Category A and increased for Seismic Design Category C and D. None of the locations selected were Seismic Design Category E or F due in part to the assumed soil Site Class D.

The environmental location factor for snow loading is based on an Importance Factor of 1.00. The ground snow load was determined using the ASCE 7-16 Hazard Tool; however, the value for Boise, Idaho was based on data from ASCE 7-10 because data from ASCE 7-16 was unavailable. The ground snow load for case study areas assumed 50 pounds per square foot. The baseline was the approximate average ground snow load for the location data set; therefore, the factor was reduced for locations lower than the average and increased for locations above the average.

The environmental location factor for tsunami loading is based on ASCE 7-16 methodology and an article published by *The Seattle Times* regarding the cost implications of incorporating tsunami-resistant features into the first building designed using the methodology. The environmental location factor included tsunami effects for one location: Seattle, Washington.

---

<sup>1</sup> Determined using the web interface on <https://seismicmaps.org/>. The Structural Engineers Association of California's and California's Office of Statewide Health Planning and Development developed this web interface that uses the open source code provided by the United States Geological Survey to retrieve the seismic design data. This website does not perform any calculations to the table values.



### **Additional Location Factor Considerations**

Base costs for the thermal power cases were determined assuming no significant constraints with respect to available water resources, wastewater discharge requirements, and ambient temperature extremes. In areas where these constraints are expected to add significantly to the installed equipment, we applied location adjustments to the capital costs. To account for locations with limited water resources, such as California, the southwest, and the mountain west regions, air-cooled condensers are used in lieu of mechanical draft cooling towers. In regions where wastewater loads to rivers and reservoirs are becoming increasingly restricted, zero liquid discharge (ZLD) equipment is added. Zero liquid discharge wastewater treatment equipment is assumed to include reverse osmosis, evaporation/crystallization, and fractional electrode ionization. To reduce the loading for the ZLD systems, it is assumed that cases where ZLD is applied will also have equipment in place to reduce wastewater such as air-cooled condensers or cooling tower blowdown treatment systems.

To account for ambient temperature extremes, costs for boiler enclosures have been included as part of the location factors in areas where ambient temperatures will be below freezing for significant periods of time. Costs for boiler enclosures are applied to the coal-fired cases and the biomass cases, but not to the CC heat recovery steam generators, which are assumed to open in all regions. It is assumed that the steam turbine generator (STG) equipment will be enclosed for all cases in all locations.

### **OPERATING & MAINTENANCE COST ESTIMATING**

Once a plant enters commercial operation, the plant owners incur fixed O&M as well as variable O&M costs each year. Operations and maintenance costs presented in this report are non-fuel related.

Fixed O&M costs include costs directly related to the equipment design including labor, materials, contract services for routine O&M, and administrative and general costs. Not included are other fixed operating costs related to the location, notably property taxes and insurance. Labor, maintenance, and minor repairs and general and administrative (G&A) costs were estimated based on a variety of sources including actual projects, vendor publications, and Sargent & Lundy's internal resources. Variable O&M costs, such as ammonia, water, and miscellaneous chemicals and consumables, are directly proportional to the plant generating output.



## Fixed O&M

Fixed O&M costs are those incurred at a power plant which do not vary with generation. Fixed O&M typically includes the following expenses:

- Routine Labor
- Materials and Contract Services
- Administrative and General Expenses

Routine labor includes the regular maintenance of the equipment as recommended by the equipment manufacturers. This includes maintenance of pumps, compressors, transformers, instruments, controls, and valves. The power plant's typical design is such that routine labor activities do not require a plant outage.

Materials and contract services include the materials associated with the routine labor as well as contracted services such as those covered under a long-term service agreement, which has recurring monthly payments.

General and administrative expenses are operation expenses, which include leases, management salaries, and office utilities.

For the hydro, solar, wind, and battery energy storage cases, all O&M costs are treated as fixed costs.

## Variable O&M

Variable O&M costs are generation-based costs that vary based on the amount of electrical generation at the power plant. These expenses include water consumption, waste and wastewater discharge, chemicals such as selective catalytic reduction ammonia, and consumables including lubricants and calibration gas.



# Cases



---

## **CASE 1.      ULTRA-SUPERCRITICAL COAL WITHOUT CO<sub>2</sub> CAPTURE, 650 MW**

### **1.1    CASE DESCRIPTION**

This case comprises a coal-fired power plant with a nominal net capacity of 650 megawatts (MW) with a single steam generator and steam turbine with coal storage and handling systems, balance-of-plant (BOP) systems, and emissions control systems; there are no carbon dioxide (CO<sub>2</sub>) capture systems. This case employs a modified Rankine cycle, referred to as an ultra-supercritical (USC) thermal cycle, which is characterized by operation at supercritical pressures at approximately 3750 psia<sup>2</sup> and at steam temperatures above 1100°F (degrees Fahrenheit). This increase in steam pressure and steam temperature provides more energy per pound of fuel that can be converted to shaft power in the steam turbine. The USC steam cycles are a significant improvement from the more common subcritical cycles. USC technology, therefore, represents the most efficient steam cycle currently available. These higher efficiency boilers and turbines require less coal and consequently produce less greenhouse gases and lower emissions. Throughout the past decade, many USC coal plants have been placed in operation, although most of these facilities have been constructed in Europe and Asia. Figure 1-1 is a view of the first U.S. USC coal facility, which began operation in 2012.

---

<sup>2</sup> Pounds per square inch absolute







## 1.1.1 Mechanical Equipment & Systems

### 1.1.1.1 USC Steam Cycle

The steam turbine is a tandem compound reheat machine consisting of a high-pressure turbine, an intermediate-pressure turbine, and two double-flow low-pressure turbines with horizontal casing splits. The USC thermal cycle comprises eight feedwater heaters, with the eighth heater supplied with extraction steam from the high-pressure turbine. This heater configuration is commonly referred to as a “HARP” system, which is a Heater Above Reheat Point of the turbine steam flow path. Boiler feedwater is pressured with a single high-pressure boiler feedwater pump, which is driven with an electric motor. (For the larger boiler size described in the 90% carbon capture case [Case 3], the boiler feedwater pump is steam turbine driven, with the turbine exhaust directed to the low-pressure condenser). Steam leaves the boiler to a high-pressure steam turbine designed for the USC pressures and temperatures. Steam leaving the high-pressure turbine is reheated in the boiler and directed to the intermediate-pressure turbine. The low-pressure turbine sections are twin dual flow turbines. The condensers are multi-flow units, one per each dual flow low-pressure turbine, operated at 2.0 inches of mercury absolute. The plant cooling system uses mechanical draft cooling towers with a circulated water temperature rise of 20°F.

The plant performance estimate is based on ambient conditions of 59°F, 60% relative humidity, and sea level elevation. The boiler efficiency is assumed to be 87.5%. The gross plant output is estimated to be 735 MW with a net output of 650 MW. The net heat rate is estimated to be 8638 Btu/kWh (British thermal unit per kilowatt hour) based on the higher heating value (HHV) of the fuel and the net electrical output.

### 1.1.1.2 Steam Generator

For the base case design, the single steam generator is designed for an outdoor location. The steam generator is a USC, pulverized-coal-fired type, balanced draft, once-through unit equipped with superheater, reheater, economizer, and regenerative air heaters. All materials of construction are selected to withstand the pressures and temperatures associated with the USC conditions are in accordance with Section 1 of the ASME BPVC. The boiler is fired with pulverized bituminous coal through six pulverizers. The boiler-firing system consists of low-nitrogen oxide (NO<sub>x</sub>) burners (LNBS) and overfire air (OFA). A submerged flight conveyor system is used for bottom ash removal. An economizer preheats the feedwater prior to entering the boiler water walls. Combustion air is preheated with two parallel trisector air preheaters. Combustion air is delivered to the boiler by two forced draft



fans and two primary air fans. Two axial induced draft fans are used to transfer combustion gases through a baghouse, wet flue gas desulfurization (WFGD) system, and wet chimney.

#### **1.1.1.3 Water Treatment**

The facility's water treatment plant consists of pretreatment and demineralization. All raw water entering the facility is first sent to the pretreatment system, which mainly consists of two redundant clarifiers where chemicals are added for disinfection and suspended solids removal. The pretreatment system includes lime addition, allowing for the partial removal of hardness and alkalinity from the raw water if required. After pretreatment, the water is sent to a storage tank and then directed to the service and firewater users. A demineralizer system is used to provide steam cycle makeup water of sufficient quality for the once-through system. All wastewater from the demineralizer system is either recycled to the WFGD system or sent to the wastewater neutralization and discharge system.

#### **1.1.1.4 Material Handling**

The coal handling system includes rail car unloading, reclaim systems, dual coal conveyor system, transfer towers, and coal crushers. The fly ash handling system includes equipment to remove ash from the boiler, economizer, air heater, and baghouse. Fly ash is collected dry and conveyed to a storage silo. Fly ash is collected from the storage by truck for offsite disposal.

#### **1.1.2 Electrical & Control Systems**

The USC facility generator is rated at approximately 780 megavolt-ampere (MVA) with an output of 24 kilovolts (kV) and is connected via generator circuit breakers to a generator step-up transformer (GSU). The GSU increases the voltage from the generator voltage level to the transmission system high-voltage level. The electrical system includes auxiliary transformers and reserve auxiliary transformers. The facility and most of the subsystems are controlled using a central distributed control system (DCS).

#### **1.1.3 Offsite Requirements**

Coal is delivered to the facility by rail. The maximum daily coal rate for the facility is approximately 4600 tons per day. The approximate number of rail cars to support this facility is estimated at approximately 330 rail cars per week.

The site is assumed to be located adjacent to a river or reservoir that can be permitted to supply a sufficient quantity of cooling water. The total volume of water required for cooling tower makeup, cycle makeup, and other demands is estimated to be approximately 7,000 gallons per minute. Wastewater is



sent to the adjacent waterway from one or more outfalls from a water treatment pond or wastewater treatment system.

The facility is assumed to start up on natural gas; therefore, the site is connected to a gas distribution system. Natural gas interconnection costs are based on a new lateral connected to existing gas pipeline.

The electrical interconnection costs are based on a one-mile distance from the facility switchyard to the terminal point on an existing utility substation. For the purposes of this estimate, the cost associated with the expansion of the substation is excluded.

## 1.2 CAPITAL COST ESTIMATE

The base cost estimate for this technology case totals \$3676/kilowatt (kW). Table 1-1 summarizes the cost components for this case. The basis of the estimate assumes that the site is constructed in a United States region that has good access to lower-cost construction labor and has reasonable access to water resources, coal, natural gas, and existing utility transmission substations or existing transmission lines. The geographic location is assumed to be characterized by seismic, wind, and other loading criteria that do not add significantly to the capital costs. An outdoor installation is assumed, meaning that the boiler building is not enclosed, and no special systems are needed to prevent freezing or to account for snow loads on structures.

To determine the capital costs adjustments in other United States regions where the assumptions listed above are not applicable, location factors have been calculated to account for variations in labor wage rates and access to construction labor, labor productivity, water and wastewater resource constraints, wind and seismic criteria, and other environmental criteria.

To account for locations where water resources are limited, such as California, the southwest and the mountain west regions, air-cooled condensers (ACCs) are used in lieu of mechanical draft cooling towers. In regions where wastewater loads to rivers and reservoirs are becoming increasingly restricted, zero liquid discharge (ZLD) equipment is added. Zero liquid discharge wastewater treatment equipment is assumed to include reverse osmosis, evaporation/crystallization, and fractional electrode ionization. To reduce the loading for the ZLD systems, it is assumed that cases where ZLD is applied will also have equipment in place, such as ACCs or cooling tower blowdown treatment systems, to reduce wastewater.



To account for ambient temperature extremes, costs for boiler enclosures have been included as part of the location factors in areas where ambient temperatures will be below freezing for significant periods of time. It is assumed that the STG equipment will be enclosed in all locations.

**Table 1-1 — Case 1 Capital Cost Estimate**

<b>Case 1 EIA – Capital Cost Estimates – 2019 \$s</b>		
<b>Configuration</b>	<b>650 MW Net Ultra-Supercritical Coal w/o Carbon Capture – Greenfield</b>	
<b>Combustion Emissions Controls</b>	1 x 735 MW Gross Low NOx Burners / OFA	
<b>Post-Combustion Emissions Controls</b>	SCR / Baghouse/ WFGD / WESP	
<b>Fuel Type</b>	High Sulfur Bituminous	
<b>Units</b>		
<b>Plant Characteristics</b>		
Net Plant Capacity (60 deg F, 60% RH)	MW	650
Heat Rate, HHV Basis	Btu/kWh	8638
<b>Capital Cost Assumptions</b>		
EPC Contracting Fee	% of Direct & Indirect Costs	10%
Project Contingency	% of Project Costs	12%
Owner's Services	% of Project Costs	7%
Estimated Land Requirement (acres)	\$	300
Estimated Land Cost (\$/acre)	\$	30,000
<b>Interconnection Costs</b>		
<i>Electrical Transmission Line Costs</i>		
	\$/mile	2,520,000
Miles	miles	1.00
Substation Expansion	\$	0
<i>Gas Interconnection Costs</i>		
Pipeline Cost	\$/mile	2,500,000
Miles	miles	0.50
Metering Station	\$	3,600,000
<b>Typical Project Timelines</b>		
Development, Permitting, Engineering	months	24
Plant Construction Time	months	36
Total Lead Time Before COD	months	60
Operating Life	years	40
<b>Cost Components (Note 1)</b>		
	<b>Breakout</b>	<b>Total</b>
<i>Civil/Structural/Architectural Subtotal</i>	\$	235,200,000
Mechanical – Boiler Plant	\$	905,100,000
Mechanical – Turbine Plant	\$	155,200,000
Mechanical – Balance of Plant	\$	19,300,000
<b>Mechanical Subtotal</b>	<b>\$</b>	<b>1,079,600,000</b>
Electrical – Main Power System	\$	18,100,000
Electrical – Aux Power System	\$	22,800,000
Electrical – BOP and I&C	\$	104,900,000
Electrical – Substation and Switchyard	\$	15,100,000
<b>Electrical Subtotal</b>	<b>\$</b>	<b>160,900,000</b>
Project Indirects	\$	323,200,000
EPC Total Before Fee	\$	1,798,900,000
EPC Fee	\$	179,890,000
<b>EPC Subtotal</b>	<b>\$</b>	<b>1,978,790,000</b>



<b>Case 1</b>		
<b>EIA – Capital Cost Estimates – 2019 \$s</b>		
<b>Configuration</b>	<b>650 MW Net Ultra-Supercritical Coal w/o Carbon Capture – Greenfield</b>	
<b>Combustion Emissions Controls</b>	1 x 735 MW Gross Low NOx Burners / OFA	
<b>Post-Combustion Emissions Controls</b>	SCR / Baghouse/ WFGD / WESP	
<b>Fuel Type</b>	High Sulfur Bituminous	
<b>Units</b>		
<b>Owner's Cost Components (Note 2)</b>		
Owner's Services	\$	138,515,000
Land	\$	9,000,000
Electrical Interconnection	\$	2,520,000
Gas Interconnection	\$	4,850,000
<b>Owner's Cost Subtotal</b>	<b>\$</b>	<b>154,885,000</b>
<b>Project Contingency</b>	<b>\$</b>	<b>256,041,000</b>
<b>Total Capital Cost</b>	<b>\$</b>	<b>2,389,716,000</b>
<b>\$/kW net</b>		<b>3,676</b>
<b>Capital Cost Notes</b>		
<p>1. Costs based on EPC contracting approach. Direct costs include equipment, material, and labor to construct the civil/structural, mechanical, and electrical/I&amp;C components of the facility. Indirect costs include distributable material and labor costs, cranes, scaffolding, engineering, construction management, startup and commissioning, and contractor overhead. EPC fees are applied to the sum of direct and indirect costs.</p> <p>2. Owner's costs include project development, studies, permitting, legal, owner's project management, owner's engineering, and owner's startup and commissioning costs. Other owner's costs include electrical interconnection costs, gas interconnection costs (if applicable), and land acquisition costs.</p>		

### 1.3 O&M COST ESTIMATE

The operating and maintenance costs for the USC coal-fired power generation facility are summarized in Table 1-2. The fixed costs cover the operations and maintenance (O&M) labor, contracted maintenance services and materials, and general and administrative (G&A). Major overhauls for the facility are generally based on a three-year/six-year basis depending on the equipment. Major steam turbine maintenance work is generally performed on a five- to six-year cycle, while shorter outages (e.g., change out selective catalytic reduction [SCR] catalyst) are generally performed on a three-year cycle.

Non-fuel variable costs for this technology case include flue gas desulfurization (FGD) reagent costs, SCR catalyst replacement costs, SCR reagent costs, water treatment costs, wastewater treatment costs, fly ash and bottom ash disposal costs, bag replacement for the fabric filters, and FGD waste disposal costs.



Table 1-2 — Case 1 O&amp;M Cost Estimate

<b>Case 1</b>		
<b>EIA – Non-Fuel O&amp;M Costs – 2019 \$\$</b>		
650 MW Net, Ultra-Supercritical Coal w/o Carbon Capture – Greenfield		
<b>Fixed O&amp;M – Plant (Note 1)</b>		
Labor	\$/year	15,317,000
Materials and Contract Services	\$/year	7,830,000
Administrative and General	\$/year	<u>3,233,000</u>
Subtotal Fixed O&M	\$/year	26,380,000
\$/kW-year	\$/kW-year	<b>40.58 \$/kW-year</b>
<b>Variable O&amp;M (Note 2)</b>	\$/MWh	<b>4.50 \$/MWh</b>
<b>O&amp;M Cost Notes</b>		
1. Fixed O&M costs include labor, materials and contracted services, and G&A costs. O&M costs exclude property taxes and insurance.		
2. Variable O&M costs include catalyst replacement, ammonia, limestone, water, ash disposal, FGD waste disposal, and water discharge treatment cost.		

## 1.4 ENVIRONMENTAL & EMISSIONS INFORMATION

The emissions for the major criteria pollutants are summarized in Table 1-3. The NO<sub>x</sub> emissions assume that the in-furnace controls such as LNB, OFA, and SCR systems are employed to control emissions to 0.06 pounds per one million British thermal units (lb/MMBtu). The WFGD system is assumed to be capable of 98% reduction of SO<sub>2</sub> from an inlet loading of 4.3 lb/MMBtu. The CO<sub>2</sub> emissions estimates are based on the default CO<sub>2</sub> emissions factors listed in Table C-1 of 40 CFR 98, Subpart C.

Table 1-3 — Case 1 Emissions

<b>Case 1</b>		
<b>EIA – Emissions Rates</b>		
650 MW Net, Ultra-Supercritical Coal w/o Carbon Capture – Greenfield		
<b>Predicted Emissions Rates (Note 1)</b>		
NO <sub>x</sub>	lb/MMBtu	0.06 (Note 2)
SO <sub>2</sub>	lb/MMBtu	0.09 (Note 3)
CO <sub>2</sub>	lb/MMBtu	206 (Note 4)
<b>Emissions Control Notes</b>		
1. High sulfur Bituminous Coal, 4.3 lb/MMBtu SO <sub>2</sub> Coal		
2. NO <sub>x</sub> Removal using LNBs with OFA, and SCR		
3. SO <sub>2</sub> Removal by Forced Oxidation, Limestone Based, Wet FGD, 98% Reduction		
4. Per 40 CFR 98, Subpt. C, Table C-1		

The post-combustion environmental controls for this technology case include an SCR NO<sub>x</sub> system with aqueous ammonia as the reagent, a fabric-filter baghouse ash collection system with pulse jet cleaning, and a limestone-based forced-oxidation WFGD for the removal of SO<sub>2</sub> and sulfur trioxide. A wet electrostatic precipitator is included to mitigate sulfuric acid emissions. The flue gas pressure drops incurred from these backend controls have been accounted for in the induced draft fan sizing and the resultant auxiliary power demands in addition to the auxiliary power demands for the emissions control systems themselves.



For this case, no CO<sub>2</sub> emissions controls are assumed to be applicable. Please refer to Case 2 for 30% carbon capture and Case 3 for 90% carbon capture.





## **CASE 2. ULTRA-SUPERCRITICAL COAL WITH 30% CO<sub>2</sub> CAPTURE, 650 MW**

### **2.1 CASE DESCRIPTION**

This case comprises a coal-fired power plant with a nominal net capacity of 650 MW with a single steam generator and steam turbine with coal storage and handling systems, BOP systems, emissions control systems, and a 30% CO<sub>2</sub> capture system. This technology case is similar to the plant description provided in Case 1; however, this case employs CO<sub>2</sub> capture systems that require a larger boiler size and higher heat input to account for the low-pressure steam extraction and larger auxiliary loads needed for the CO<sub>2</sub> capture technology used. The CO<sub>2</sub> capture systems are commonly referred to as carbon capture and sequestration system (CCS) systems; however, for the cost estimates provided in this report, no sequestration costs have been included. For this case, the CO<sub>2</sub> captured is assumed to be compressed to supercritical conditions and injected into a pipeline terminated at the fence line of the facility. For this report, the terms “CO<sub>2</sub> capture” and “carbon capture” are used interchangeably.

As with Case 1, the base configuration used for the cost estimate is a single-unit station constructed on a greenfield site of approximately 300 acres with rail access for coal deliveries. The facility has a nominal net generating capacity of 650 MW and is assumed to fire a high sulfur bituminous coal with fuel moisture at 11% to 13% by weight and ash at 9% to 10%. Mechanical draft cooling towers are used for cycle cooling, and the water used for cycle cooling and steam cycle makeup is provided by an adjacent fresh water reservoir or river.

#### **2.1.1 Mechanical Equipment & Systems**

Refer to Case 1 for a description of the major mechanical equipment and systems associated with the USC power generation facility. This section provides a description of the major CO<sub>2</sub> capture systems used as the basis for the capital and O&M cost estimates.

##### **2.1.1.1 General CO<sub>2</sub> Capture Description**

The most commercially available CO<sub>2</sub> capture technology for coal-fired power plants is amine-based scrubbing technology. This technology requires an absorption column to absorb the CO<sub>2</sub> from the flue gas and a stripping column to regenerate the solvent and release the CO<sub>2</sub>. Amine-based solvents are used in the absorption column and require periodic makeup streams and waste solvent reclamation. Steam is used to break the bond between the CO<sub>2</sub> and solvent. CO<sub>2</sub> leaves the stripper with moisture prior to being dehydrated and compressed. The product CO<sub>2</sub> is pipeline quality at 99.5% purity and



approximately 2215 psia. The amine-based solvent systems are typically designed for 90% CO<sub>2</sub> capture in the absorption column.

#### **2.1.1.2 CO<sub>2</sub> Capture Systems**

This case assumes being built with full integration to the CO<sub>2</sub> capture facility. The CO<sub>2</sub> capture technology uses various utilities to operate, including low-quality steam and auxiliary power. Steam can be extracted between the intermediate pressure and low-pressure turbine sections that will provide the least amount of capacity derate while maintaining the necessary energy to drive the CO<sub>2</sub> capture system. Extracting steam prior to the low-pressure turbine section requires additional fuel to be fired to account for the lost generation potential. As such, the boiler, turbine, and associated systems would be required to be made larger to maintain the same net power production. Additionally, the CO<sub>2</sub> capture facility and BOP associated with the CO<sub>2</sub> capture system requires a significant amount of auxiliary power to drive the mechanical equipment. Most of the power consumption is used to drive the CO<sub>2</sub> compressors to produce pipeline quality CO<sub>2</sub> at approximately 2215 psia. The increase in auxiliary power consumption due to the CO<sub>2</sub> facility usage will require a larger turbine throughput to produce the added output. Overall, CO<sub>2</sub> capture system integration can account for a net derate of approximately 30% in comparison with the base facility power output.

Other utilities that are integrated with the base plant are demineralized water and cooling water. Demineralized water is used to maintain a water balance within the amine process or in the solvent regeneration stages. The demineralized water consumption rate for the CO<sub>2</sub> capture facility is typically minor in comparison with base-plant utilization rates. As such, the demineralized water is expected to be fed from the base facility. This cost is accounted for in the O&M estimate only. Conversely, cooling water demands for the carbon capture process is significant. CO<sub>2</sub> capture systems require circulating cooling water rates similar to that of the condensers. As such, the cooling system, in this case evaporative cooling towers, are required to be expanded to account for the large amount of additional heat rejection. This cost is accounted for in the capital and O&M estimates. The increase in cooling tower size also requires a higher cooling tower blowdown rate that needs to be treated at the wastewater treatment system. This cost is reflected in the capital and O&M estimates.

Commercial amine-based CO<sub>2</sub> capture technology requires a quencher to be located upstream of the CO<sub>2</sub> absorber vessel. The quencher is used to cool the flue gas to optimize the kinetics and efficiency of the CO<sub>2</sub> absorption process via the amine-based solvent. During the quenching process, a significant amount of flue gas moisture condenses into the vessel and requires a significant amount of blowdown

to maintain the level in the vessel. This blowdown quality is not good enough to reuse in the absorber system for water balance, but it is an acceptable quality to either reuse in the cooling towers or WFGD for makeup water. Due to the reuse, it does not require additional O&M costs.

A generic flow diagram for post-combustion carbon capture system is provided in Figure 2-1. The termination of the process of the CO<sub>2</sub> capture facility is the new emissions point, which is a small stack at the top of the CO<sub>2</sub> absorber vessel. For this configuration, a typical free-standing chimney is not required. Additionally, the compressed product CO<sub>2</sub> is the other boundary limit. This estimate does not include pipeline costs to transport the CO<sub>2</sub> to a sequestration or utilization site.

**Figure 2-1 — Carbon Capture Flow Diagram**

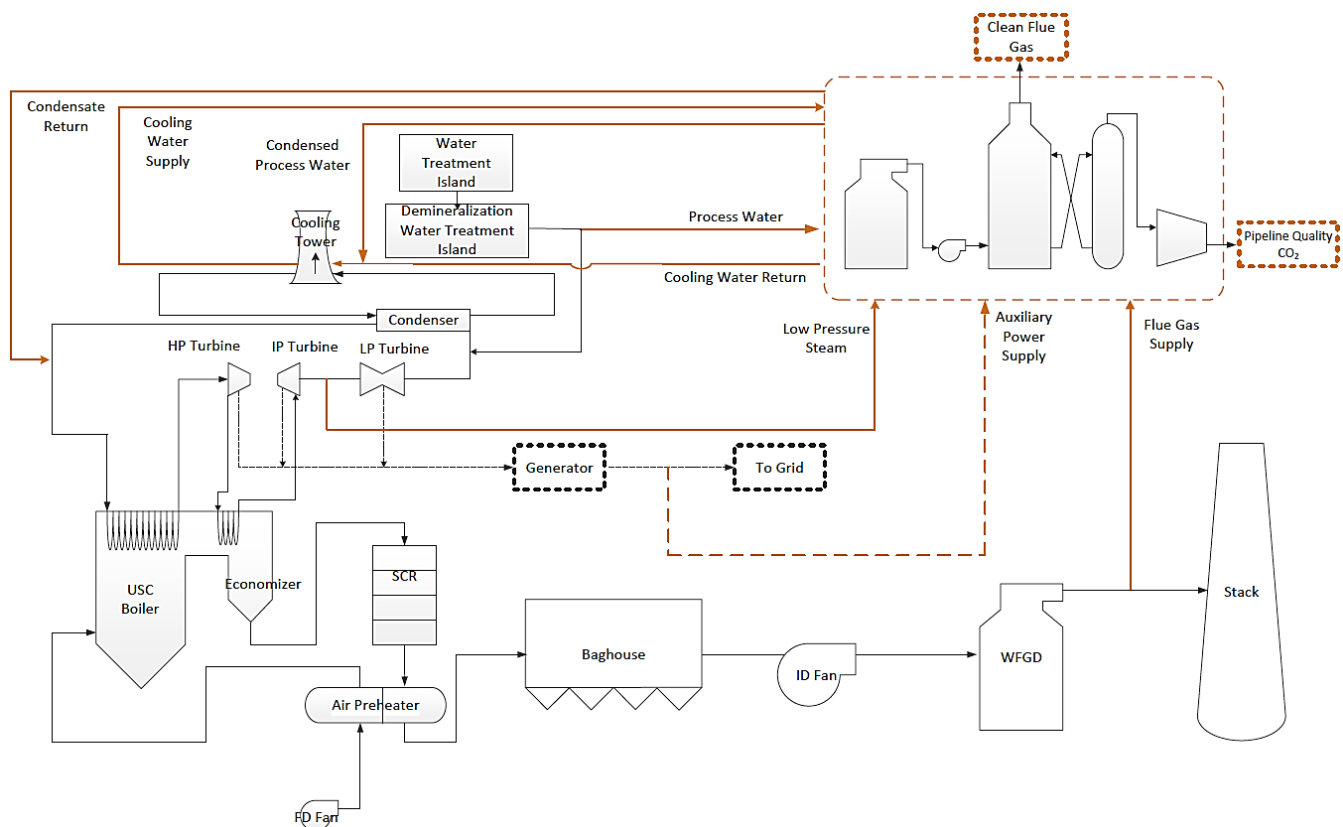

### 2.1.1.3 30% CO<sub>2</sub> Capture

For this technology case, the USC coal-fired facility is required to provide 30% CO<sub>2</sub> reduction; approximately one-third of the total flue gas must be treated. As referenced previously, 90% capture is the typical design limit for CO<sub>2</sub> reduction in the absorber. Therefore, 33% of the plant's flue gas would need to be treated to provide 90% reduction efficiency. A slipstream of the flue gas downstream of the



WFGD system would be extracted and sent to the CO<sub>2</sub> capture island. The remaining flue gas would exit through a typical free-standing wet chimney.

In this scenario, a significant amount of steam and auxiliary power is required to drive the large CO<sub>2</sub> capture system, ultimately increasing the size of the boiler to generate the additional steam and power required to maintain a net power output of 650 MW. As the boiler gets larger, more flue gas must be treated. As such, it is an iterative process to determine the new boiler size necessary to treat 33% of the flue gas from a new USC coal-fired boiler. Ultimately, the boiler would be built with a larger heat input than the non-CO<sub>2</sub> capture cases; however, the increase in size would be much less than the 90% capture case.

#### **2.1.1.4 Plant Performance**

The plant performance estimate is based on ambient conditions of 59°F, 60% relative humidity, sea level elevation, and 30% CO<sub>2</sub> capture. Approximately 790,000 pound per hour of low-pressure steam is required for the CO<sub>2</sub> system. While the boiler efficiency is assumed to be 87.5%, the estimated gross size of the steam generator is approximately 827 MW, which is approximately 13% larger than the case without carbon capture (Case 1). The estimated total auxiliary load for the plant is 119.5 MW with 28 MW required for the CO<sub>2</sub> system. The net heat rate is estimated to be 9751 Btu/kWh based on the HHV of the fuel and the net electrical output.

#### **2.1.2 Electrical & Control Systems**

The electrical equipment includes the turbine generator, which connects via generator circuit breakers to a GSU. The GSU increases the voltage from the generator voltages level to the transmission system high-voltage level. The electrical system is essentially similar to the USC case without carbon capture (Case 1); however, there are additional electrical transformers and switchgear for the CO<sub>2</sub> capture systems. The electrical system includes auxiliary transformers and reserve auxiliary transformers. The facility and most of the subsystems are controlled using a central DCS.

#### **2.1.3 Offsite Requirements**

Coal is delivered to the facility by rail. The maximum daily coal rate for the facility is approximately 5200 tons per day. The approximate number of rail cars to support this facility is estimated at approximately 360 rail cars per week.



The site is assumed to be located adjacent to a river or reservoir that can be permitted to supply a sufficient quantity of cooling water. The estimated total volume of water required for cooling tower makeup, cycle makeup, and cooling for the CO<sub>2</sub> system is approximately 10,000 gallons per minute. Wastewater is sent to the adjacent waterway from one or more outfalls from a water treatment pond or wastewater treatment system.

The CO<sub>2</sub> captured will need to be sequestered in a geologic formation or used for enhanced oil recovery. The viability of this technology case will be driven, to a large extent, by the proximity of the facility to appropriate geologic formations. The costs presented herein do not account for equipment, piping, or structures associated with CO<sub>2</sub> sequestration.

The facility is assumed to start up on natural gas; therefore, the site is connected to a gas distribution system. Natural gas interconnection costs are based on a new lateral connected to existing gas pipeline.

The electrical interconnection costs are based on a one-mile distance from the facility switchyard to the terminal point on an existing utility substation. For the purposes of this estimate, the cost associated with the expansion of the substation is excluded.

## 2.2 CAPITAL COST ESTIMATE

The base cost estimate for this technology case totals \$4558/kW. Table 2-1 summarizes the cost components for this case. Cost associated with CO<sub>2</sub> sequestration have been excluded. The basis of the estimate assumes that the site is constructed in a United States region that has good access to lower-cost construction labor and has reasonable access to water resources, coal, natural gas, and existing utility transmission substations or existing transmission lines. The geographic location is assumed to be characterized by seismic, wind, and other loading criteria that do not add significantly to the capital costs. An outdoor installation is assumed, meaning that the boiler building is not enclosed. No special systems are needed to prevent freezing or to account for snow loads on structures.

To determine the capital costs adjustments in other United States regions where the assumptions listed above are not applicable, location factors have been calculated to account for variations in labor wage rates and access to construction labor, labor productivity, water and wastewater resource constraints, wind and seismic criteria, and other environmental criteria.

To account for locations where water resources are limited, such as California and the southwest and the mountain west regions, ACCs are used in lieu of mechanical draft cooling towers. In regions where



wastewater loads to rivers and reservoirs are becoming increasingly restricted, ZLD equipment is added. Zero liquid discharge wastewater treatment equipment is assumed to include reverse osmosis, evaporation/crystallization, and fractional electrode ionization. To reduce the loading for the ZLD systems, it is assumed that cases where ZLD is applied will also have equipment in place, such as ACCs or cooling tower blowdown treatment systems, to reduce wastewater.

To account for ambient temperature extremes, costs for boiler enclosures have been included as part of the location factors in areas where ambient temperatures will be below freezing for significant periods of time. It is assumed that the STG equipment will be enclosed in all locations.

**Table 2-1 — Case 2 Capital Cost Estimate**

<b>Case 2 EIA – Capital Cost Estimates – 2019 \$\$</b>			
<b>Configuration</b>	<b>650 MW Net, Ultra-Supercritical Coal w/ 30% Carbon Capture</b> 1 x 769 MW Gross Low NOx Burners / OFA SCR / Baghouse/ WFGD / WESP - AMINE Based CCS High Sulfur Bituminous		
<b>Combustion Emissions Controls</b>			
<b>Post-Combustion Emissions Controls</b>			
<b>Fuel Type</b>			
<b>Units</b>			
<b>Plant Characteristics</b>			
Net Plant Capacity (60 deg F, 60% RH)	MW	650	
Heat Rate, HHV Basis	Btu/kWh	9751	
<b>Capital Cost Assumptions</b>			
EPC Contracting Fee	% of Direct & Indirect Costs	10%	
Project Contingency	% of Project Costs	12%	
Owner's Services	% of Project Costs	7%	
Estimated Land Requirement (acres)	\$	300	
Estimated Land Cost (\$/acre)	\$	30,000	
<b>Interconnection Costs</b>			
<i>Electrical Transmission Line Costs</i>			
Electrical Transmission Line Costs	\$/mile	2,520,000	
Miles	miles	1.00	
Substation Expansion	\$	0	
<i>Gas Interconnection Costs</i>			
Pipeline Cost	\$/mile	2,500,000	
Miles	miles	0.50	
Metering Station	\$	3,600,000	
<b>Typical Project Timelines</b>			
Development, Permitting, Engineering	months	24	
Plant Construction Time	months	36	
Total Lead Time Before COD	months	60	
Operating Life	years	40	
<b>Cost Components (Note 1)</b>		<b>Breakout</b>	<b>Total</b>
<i>Civil/Structural/Architectural Subtotal</i>		\$	263,200,000
Mechanical – Boiler Plant	\$	935,766,667	
Mechanical – Turbine Plant	\$	185,866,667	
Mechanical – Balance of Plant	\$	49,966,667	
<i>Mechanical Subtotal</i>		\$	1,171,600,000



<b>Case 2</b>		
<b>EIA – Capital Cost Estimates – 2019 \$\$</b>		
<b>Configuration</b>	<b>650 MW Net, Ultra-Supercritical Coal w/ 30% Carbon Capture</b> 1 x 769 MW Gross Low NOx Burners / OFA SCR / Baghouse/ WFGD / WESP - AMINE Based CCS High Sulfur Bituminous	
<b>Combustion Emissions Controls</b>		
<b>Post-Combustion Emissions Controls</b>		
<b>Fuel Type</b>		
	<b>Units</b>	
Electrical – Main Power System	\$	21,100,000
Electrical – Aux Power System	\$	25,800,000
Electrical – BOP and I&C	\$	107,900,000
Electrical – Substation and Switchyard	\$	18,100,000
<i>Electrical Subtotal</i>	\$	172,900,000
<i>CCS Plant Subtotal</i>	\$	278,752,000
Project Indirects	\$	347,200,000
EPC Total Before Fee	\$	2,233,652,000
EPC Fee	\$	223,365,200
<b><i>EPC Subtotal</i></b>	<b>\$</b>	<b>2,457,017,200</b>
<b>Owner's Cost Components (Note 2)</b>		
Owner's Services	\$	171,991,000
Land	\$	9,000,000
Electrical Interconnection	\$	2,520,000
Gas Interconnection	\$	4,850,000
<b><i>Owner's Cost Subtotal</i></b>	<b>\$</b>	<b>188,361,000</b>
<b><i>Project Contingency</i></b>	<b>\$</b>	<b>317,445,000</b>
<b>Total Capital Cost</b>	<b>\$</b>	<b>2,962,823,200</b>
	<b>\$/kW net</b>	<b>4,558</b>
<b>Capital Cost Notes</b>		
<p>1. Costs based on EPC contracting approach. Direct costs include equipment, material, and labor to construct the civil/structural, mechanical, and electrical/I&amp;C components of the facility. Indirect costs include distributable material and labor costs, cranes, scaffolding, engineering, construction management, startup and commissioning, and contractor overhead. EPC fees are applied to the sum of direct and indirect costs.</p> <p>2. Owner's costs include project development, studies, permitting, legal, owner's project management, owner's engineering, and owner's startup and commissioning costs. Other owner's costs include electrical interconnection costs, gas interconnection costs (if applicable), and land acquisition costs.</p>		

## 2.3 O&M COST ESTIMATE

The O&M costs for the USC coal-fired power generation facility with 30% carbon capture are summarized in Table 2-2. The fixed costs cover the O&M labor, contracted maintenance services and materials, and G&A. Major overhauls for the facility are generally based on a three-year/six-year basis depending on the equipment. Major steam turbine maintenance work is generally performed on a five-to six-year cycle, while shorter outages (e.g., change out SCR catalyst) are generally performed on a three-year cycle. It is assumed that the carbon capture equipment would have major overhauls on a three-year cycle, but there is not a sufficient operating base to confidently predict the required frequency of major maintenance. The carbon capture equipment will require additional O&M labor. It is assumed



that some type of service agreement would be needed for the compressors, absorbers, strippers, and other specialized equipment.

Non-fuel variable costs for this technology case include FGD reagent costs, SCR catalyst replacement costs, SCR reagent costs, water treatment costs, wastewater treatment costs, fly ash and bottom ash disposal costs, bag replacement for the fabric filters, FGD waste disposal costs, and solvent makeup. For the CO<sub>2</sub> capture system, variable costs include solvent makeup and disposal costs (usually offsite disposal; the spent solvent may be considered hazardous waste), additional wastewater treatment costs (predominantly combustion turbine [CT] blowdown treatment), and additional demineralized makeup water costs.

**Table 2-2 — Case 2 O&M Cost Estimate**

<b>Case 2</b>		
<b>EIA – Non-Fuel O&amp;M Costs – 2019 \$s</b>		
650 MW Net, Ultra-Supercritical Coal w/ 30% Carbon Capture		
<b>Fixed O&amp;M – Plant (Note 1)</b>		
Labor	\$/year	18,177,000
Materials and Contract Services	\$/year	10,959,000
Administrative and General	\$/year	<u>6,156,000</u>
Subtotal Fixed O&M	\$/year	35,292,000
\$/kW-year	\$/kW-year	<b>54.30 \$/kW-year</b>
<b>Variable O&amp;M (Note 2)</b>	\$/MWh	<b>7.08 \$/MWh</b>
<b>O&amp;M Cost Notes</b>		
1. Fixed O&M costs include labor, materials and contracted services, and G&A costs. O&M costs exclude property taxes and insurance.		
2. Variable O&M costs include catalyst replacement, ammonia, limestone, water, ash disposal, FGD waste disposal, and water discharge treatment cost.		

## 2.4 ENVIRONMENTAL & EMISSIONS INFORMATION

The emissions for the major criteria pollutants are summarized in Table 2-3. The NO<sub>x</sub> emissions assume that the in-furnace controls such as LNB, OFA, and SCR systems are employed to control emissions to 0.06 lb/MMBtu. The WFGD system is assumed to be capable of 98% reduction of SO<sub>2</sub> from an inlet loading of 4.3 lb/MMBtu. The CO<sub>2</sub> emissions estimates are based on a 30% removal from the default CO<sub>2</sub> emissions factors listed in Table C-1 of 40 CFR 98, Subpart C.





**Table 2-3 — Case 2 Emissions**

<b>Case 2</b>			
<b>EIA – Emissions Rates</b>			
650 MW Net, Ultra-Supercritical Coal w/ 30% Carbon Capture			
<b>Predicted Emissions Rates (Note 1)</b>			
NO <sub>x</sub>	lb/MMBtu	0.06	(Note 2)
SO <sub>2</sub>	lb/MMBtu	0.09	(Note 3)
CO <sub>2</sub>	lb/MMBtu	144	(Note 4)
<b>Emissions Control Notes</b>			
<ol style="list-style-type: none"> <li>1. High sulfur Bituminous Coal, 4.3 lb/MMBtu SO<sub>2</sub> Coal</li> <li>2. NO<sub>x</sub> Removal using LNBs with OFA, and SCR</li> <li>3. SO<sub>2</sub> Removal by Forced Oxidation, Limestone Based, Wet FGD, 98% Reduction</li> <li>4. 30% reduction from baseline Per 40 CFR 98, Subpt. C, Table C-1</li> </ol>			



## **CASE 3. ULTRA-SUPERCRITICAL COAL WITH 90% CO<sub>2</sub> CAPTURE, 650 MW**

### **3.1 CASE DESCRIPTION**

This case comprises a coal-fired power plant with a nominal net capacity of 650 MW with a single steam generator and ST with coal storage and handling systems, BOP systems, emissions control systems, and a 90% CO<sub>2</sub> capture system. This case is similar to the plant description provided in (Case 1) and (Case 2); however, this case employs 90% CO<sub>2</sub> capture system for the entire flue gas stream, which requires a larger boiler size and higher heat input to account for the low-pressure steam extraction and larger auxiliary loads needed for the CO<sub>2</sub> capture technology used. The steam cycle is generally similar to the UCS cases with carbon capture; however, the boiler feedwater pumps are steam driven as opposed to motor driven.

The CO<sub>2</sub> capture systems are commonly referred to as CCS systems; however, for the cost estimates provided in this report, no sequestration costs have been included. For this case, the CO<sub>2</sub> captured is assumed compressed to supercritical conditions and injected into a pipeline at terminated at the fence line of the facility. For this report, the terms “CO<sub>2</sub> capture” and “carbon capture” are used interchangeably.

As with Case 1 and Case 2, the base configuration used for the cost estimate is a single-unit station constructed on a greenfield site of approximately 300 acres with rail access for coal deliveries. The facility has a nominal net generating capacity of 650 MW and is assumed to fire a high sulfur bituminous coal (approximately 4 MMBtu/hour SO<sub>2</sub>) with fuel moisture at 11% to 13% by weight and ash at 9% to 10%. Mechanical draft cooling towers are used for cycle cooling, and the water used for cycle cooling and steam cycle makeup is provided by an adjacent fresh water reservoir or river.

#### **3.1.1 Mechanical Equipment & Systems**

Refer to Case 1 for a description of the major mechanical equipment and systems associated with the USC power generation facility. This section provides a description of the major CO<sub>2</sub> capture systems used as the basis for the capital and O&M cost estimates.

##### **3.1.1.1 General CO<sub>2</sub> Capture Description**

The most commercially available CO<sub>2</sub> capture technology for coal-fired power plants is amine-based scrubbing technology. This technology requires an absorption column to absorb the CO<sub>2</sub> from the flue



gas and a stripping column to regenerate the solvent and release the CO<sub>2</sub>. Amine-based solvents are used in the absorption column and require periodic makeup streams and waste solvent reclamation. Steam is used to break the bond between the CO<sub>2</sub> and solvent. CO<sub>2</sub> leaves the stripper with moisture prior to being dehydrated and compressed. The product CO<sub>2</sub> is pipeline quality at 99.5% purity and approximately 2215 psia. The amine based solvent systems are typically designed for 90% CO<sub>2</sub> capture in the absorption column. Please refer to Figure 2-1 for simplified process flow diagram of the CO<sub>2</sub> capture system.

### **3.1.1.2 CO<sub>2</sub> Capture Systems**

It is assumed that this case will be built with full integration to the CO<sub>2</sub> capture facility. The CO<sub>2</sub> capture technology uses various utilities to operate, including low-quality steam and auxiliary power. Steam can be extracted between the intermediate-pressure and low-pressure turbine sections, which will provide the least amount of capacity derate, while maintaining the necessary energy to drive the CO<sub>2</sub> capture system. Extracting steam prior to the low-pressure turbine section requires additional fuel to be fired to account for the lost generation potential. As such, the boiler turbine would be required to be made larger to maintain the same net power production. Additionally, the CO<sub>2</sub> capture facility and BOP associated with the CO<sub>2</sub> capture system requires a significant amount of auxiliary power to drive the mechanical equipment. Most of the power consumption is used to drive the CO<sub>2</sub> compressor to produce pipeline-quality CO<sub>2</sub> at approximately 2215 psia. The increase in auxiliary power consumption due to the CO<sub>2</sub> facility usage will require a larger turbine throughput to produce the added output. Doing so requires a larger boiler or turbine to maintain the same net power output of the facility. Overall, CO<sub>2</sub> capture system integration can account for a net derate of approximately 30% in comparison with the base facility power output.

Other utilities that are integrated with the base plant are demineralized water and cooling water. Demineralized water is used to maintain a water balance within the amine process or in the solvent regeneration stages. The demineralized water consumption rate for the CO<sub>2</sub> capture facility is typically minor in comparison with base-plant utilization rates. As such, the demineralized water is expected to be fed from the base facility. This cost is accounted for in the O&M estimate only. Conversely, Cooling water is not a minor flow rate. CO<sub>2</sub> capture systems can require similar circulating cooling water rates as condensers themselves. As such, the cooling system (in this case, evaporative cooling towers) are required to be expanded to account for the large amount of additional heat rejection. This cost is accounted for in the capital and O&M estimates. The increase in cooling tower size also requires a higher



cooling tower blowdown rate that needs to be treated at the wastewater treatment system. This cost is reflected in the capital and O&M estimates.

Commercial amine-based CO<sub>2</sub> capture technology requires a quencher to be located upstream of the CO<sub>2</sub> absorber vessel. The quencher is used to cool the flue gas to optimize the kinetics and efficiency of the CO<sub>2</sub> absorption process via the amine-based solvent. During the quenching process, a significant amount of flue gas moisture condenses into the vessel. This requires a significant amount of blowdown to maintain the level in the vessel. This blowdown quality is not good enough to reuse in the absorber system for water balance, but it is an acceptable quality to either reuse in the cooling towers or WFGD for makeup water. Due to the reuse, it does not require additional O&M costs.

A generic flow diagram for post-combustion carbon capture system is provided in Figure 2-1. The termination of the process of the CO<sub>2</sub> capture facility is the new emissions point, which is a small stack at the top of the CO<sub>2</sub> absorber vessel. For this configuration, a typical free-standing chimney is not required. Additionally, the compressed product CO<sub>2</sub> is the other boundary limit. This estimate does not include pipeline costs to transport the CO<sub>2</sub> to a sequestration or utilization site.

#### **3.1.1.3 90% CO<sub>2</sub> Capture**

For the case where a new USC coal-fired facility is required to provide 90% CO<sub>2</sub> reduction, the full flue gas path must be treated. As referenced previously, 90% capture is the typical design limit for CO<sub>2</sub> reduction in the absorber. Therefore, 100% of the plant's flue gas would need to be treated to provide 90% reduction efficiency. In this scenario, a significant amount of steam and auxiliary power is required to drive the large CO<sub>2</sub> capture system, ultimately increasing the size of the boiler to generate the additional steam and power required to maintain a net power output of 650 MW. As the boiler gets larger, more flue gas must be treated. As such, it is an iterative process to determine the new boiler size necessary to treat 100% of the flue gas from a new USC coal-fired boiler.

#### **3.1.1.4 Plant Performance**

For this case, all the flue gas is discharged from the carbon capture system, so no additional wet chimney is included in the capital cost estimate.

The plant performance estimate is based on ambient conditions of 59°F, 60% relative humidity, sea level elevation, and 90% CO<sub>2</sub> capture. Approximately 2,370,000 lb/hr of low-pressure steam is required for the CO<sub>2</sub> system. While the boiler efficiency is assumed to be 87.5%, the estimated gross size of the steam



generator is approximately 1,054 MW, which is approximately 40% larger than the case without carbon capture (Case 1). The estimated total auxiliary load for the plant is 181 MW, with 118 MW required for the for the CO<sub>2</sub> system. The net heat rate is estimated to be 12507 Btu/kWh based on the HHV of the fuel and the net electrical output.

### 3.1.2 Electrical & Control Systems

The electrical equipment includes the turbine generator, which is connected via generator circuit breakers to a GSU. The GSU increases the voltage from the generator voltage level to the transmission system high-voltage level. The electrical system is essentially similar to the USC case without carbon capture (Case 1); however, there are additional electrical transformers and switchgear for the CO<sub>2</sub> capture systems. The electrical system includes auxiliary transformers and reserve auxiliary transformers. The facility and most of the subsystems are controlled using a central DCS.

### 3.1.3 Offsite Requirements

Coal is delivered to the facility by rail. The maximum daily coal rate for the facility is approximately 6700 tons per day. The number of rail cars to support this facility is estimated at approximately 470 rail cars per week.

The site is assumed to be located adjacent to a river or reservoir that can be permitted to supply a sufficient quantity of cooling water. The total volume of water required for cooling tower makeup, cycle makeup, and cooling for the CO<sub>2</sub> system is estimated to be approximately 17,000 gallons per minute. Wastewater is sent to the adjacent waterway from one or more outfalls from a water treatment pond or wastewater treatment system.

The CO<sub>2</sub> captured will need to be sequestered in a geologic formation or used for enhanced oil recovery. The viability of this technology case will be driven, to a large extent, by the proximity of the facility to the appropriate geologic formations. The costs presented herein do not account for equipment, piping, or structures associated with CO<sub>2</sub> sequestration.

The facility is assumed to start up on natural gas, therefore the site is connected to a gas distribution system. Natural gas interconnection costs are based on a new lateral connected to existing gas pipeline.

The electrical interconnection costs are based on a one-mile distance from the facility switchyard to the terminal point on an existing utility substation. For the purposes of this estimate, the cost associated with the expansion of the substation is excluded.



### 3.2 CAPITAL COST ESTIMATE

The base cost estimate for this technology case totals \$5876/kW. Table 3-1 summarizes the cost components for this case. Cost associated with CO<sub>2</sub> sequestration have been excluded. The basis of the estimate assumes that the site is constructed in a United States region that has good access to lower-cost construction labor and has reasonable access to water resources, coal, natural gas, and existing utility transmission substations or existing transmission lines. The geographic location is assumed to be characterized by seismic, wind, and other loading criteria that do not add significantly to the capital costs. An outdoor installation is assumed, meaning that the boiler building is not enclosed. No special systems are needed to prevent freezing or to account for snow loads on structures.

To determine the capital costs adjustments in other United States regions where the assumptions listed above are not applicable, location factors have been calculated to account for variations in labor wage rates and access to construction labor, labor productivity, water, and wastewater resource constraints, wind and seismic criteria, and other environmental criteria.

To account for locations where water resources are limited, such as California and the southwest and the mountain west regions, ACCs are used in lieu of mechanical draft cooling towers. In regions where wastewater loads to rivers and reservoirs are becoming increasingly restricted, ZLD equipment is added. Zero liquid discharge wastewater treatment equipment is assumed to include reverse osmosis, evaporation/crystallization, and fractional electrode ionization. To reduce the loading for the ZLD systems, it is assumed that cases where ZLD is applied will also have equipment in place, such as ACCs or cooling tower blowdown treatment systems, to reduce wastewater.

To account for ambient temperature extremes, costs for boiler enclosures have been included as part of the location factors in areas where ambient temperatures will be below freezing for significant periods of time. It is assumed that the STG equipment will be enclosed in all locations.



Table 3-1 — Case 3 Capital Cost Estimate

<b>Case 3</b>		
<b>EIA – Capital Cost Estimates – 2019 \$\$</b>		
<b>Configuration</b>	<b>650 MW Net, Ultra-Supercritical Coal w/ 90% Carbon Capture</b>	
<b>Combustion Emissions Controls</b>	1 x 831 MW Gross	
<b>Post-Combustion Emissions Controls</b>	Low NOx Burners / OFA	
<b>Fuel Type</b>	SCR / Baghouse/ WFGD / WESP / AMINE Based CCS 90%	
	High Sulfur Bituminous	
<b>Units</b>		
<b>Plant Characteristics</b>		
Net Plant Capacity (60 deg F, 60% RH)	MW	650
Heat Rate, HHV Basis	Btu/kWh	12507
<b>Capital Cost Assumptions</b>		
EPC Contracting Fee	% of Direct & Indirect Costs	10%
Project Contingency	% of Project Costs	15%
Owner's Services	% of Project Costs	5%
Estimated Land Requirement (acres)	\$	300
Estimated Land Cost (\$/acre)	\$	30,000
<b>Interconnection Costs</b>		
<i>Electrical Transmission Line Costs</i>		
	\$/mile	2,520,000
Miles	miles	1.00
Substation Expansion	\$	0
<i>Gas Interconnection Costs</i>		
Pipeline Cost	\$/mile	2,500,000
Miles	miles	0.50
Metering Station	\$	3,600,000
<b>Typical Project Timelines</b>		
Development, Permitting, Engineering	months	24
Plant Construction Time	months	36
Total Lead Time Before COD	months	60
Operating Life	years	40
<b>Cost Components (Note 1)</b>		<b>Breakout</b>
<b>Civil/Structural/Architectural Subtotal</b>		<b>Total</b>
	\$	311,200,000
Mechanical – Boiler Plant	\$	967,433,333
Mechanical – Turbine Plant	\$	242,533,333
Mechanical – Balance of Plant	\$	92,077,778
<b>Mechanical Subtotal</b>	<b>\$</b>	<b>1,302,044,444</b>
Electrical – Main Power System	\$	26,350,000
Electrical – Aux Power System	\$	31,050,000
Electrical – BOP and I&C	\$	113,150,000
Electrical – Substation and Switchyard	\$	23,350,000
<b>Electrical Subtotal</b>	<b>\$</b>	<b>193,900,000</b>
<b>CCS Plant Subtotal</b>	<b>\$</b>	<b>663,846,000</b>
Project Indirects	\$	390,200,000
EPC Total Before Fee	\$	2,861,190,000
EPC Fee	\$	286,119,000
<b>EPC Subtotal</b>	<b>\$</b>	<b>3,147,309,000</b>
<b>Owner's Cost Components (Note 2)</b>		
Owner's Services	\$	157,365,000
Land	\$	9,000,000
Electrical Interconnection	\$	2,520,000
Gas Interconnection	\$	4,850,000



<b>Case 3</b>	
<b>EIA – Capital Cost Estimates – 2019 \$\$</b>	
<b>Configuration</b>	<b>650 MW Net, Ultra-Supercritical Coal w/ 90% Carbon Capture</b>
<b>Combustion Emissions Controls</b>	1 x 831 MW Gross Low NOx Burners / OFA
<b>Post-Combustion Emissions Controls</b>	SCR / Baghouse/ WFGD / WESP / AMINE Based CCS 90%
<b>Fuel Type</b>	High Sulfur Bituminous
<b>Units</b>	
<b>Owner's Cost Subtotal</b>	\$ 173,735,000
<b>Project Contingency</b>	\$ 498,157,000
<b>Total Capital Cost</b>	\$ 3,819,201,000
<b>\$/kW net</b>	
<b>5,876</b>	
<b>Capital Cost Notes</b>	
<p>1. Costs based on EPC contracting approach. Direct costs include equipment, material, and labor to construct the civil/structural, mechanical, and electrical/I&amp;C components of the facility. Indirect costs include distributable material and labor costs, cranes, scaffolding, engineering, construction management, startup and commissioning, and contractor overhead. EPC fees are applied to the sum of direct and indirect costs.</p> <p>2. Owner's costs include project development, studies, permitting, legal, owner's project management, owner's engineering, and owner's startup and commissioning costs. Other owner's costs include electrical interconnection costs, gas interconnection costs (if applicable), and land acquisition costs.</p>	

### 3.3 O&M COST ESTIMATE

The O&M costs for the USC coal-fired power generation facility with 90% carbon capture are summarized in Table 3-2. The fixed costs cover the O&M labor, contracted maintenance services and materials, and G&A. Major overhauls for the facility are generally based on a three-year/six-year basis depending on the equipment. Major steam turbine maintenance work is generally performed on a five-to six-year cycle, while shorter outages (e.g., change out SCR catalyst) are generally performed on a three-year cycle. It is assumed that the carbon capture equipment would have major overhauls on a three-year cycle, but there is not a sufficient operating base to confidently predict the required frequency of major maintenance. The carbon capture equipment will require additional O&M labor. It is assumed that some type of service agreement would be needed for the compressors, absorbers, strippers, and other specialized equipment.

Non-fuel Variable costs for this technology case include FGD reagent costs, SCR catalyst replacement costs, SCR reagent costs, water treatment costs, wastewater treatment costs, fly ash and bottom ash disposal costs, bag replacement for the fabric filters, FGD waste disposal costs, and solvent makeup. For the CO<sub>2</sub> capture system, variable costs include solvent makeup and disposal costs (usually offsite disposal; the spent solvent may be considered hazardous waste), additional wastewater treatment costs (predominantly CT blowdown treatment), and additional demineralized makeup water costs.





Table 3-2 — Case 3 O&amp;M Cost Estimate

<b>Case 3</b>		
<b>EIA – Non-Fuel O&amp;M Costs – 2019 \$\$</b>		
650 MW Net, Ultra-Supercritical Coal w/ 90% Carbon Capture		
<b>Fixed O&amp;M – Plant (Note 1)</b>		
Labor	\$/year	18,817,000
Materials and Contract Services	\$/year	12,051,000
Administrative and General	\$/year	<u>7,836,000</u>
Subtotal Fixed O&M	\$/year	38,704,000
\$/kW-year	\$/kW-year	<b>59.54 \$/kW-year</b>
<b>Variable O&amp;M (Note 2)</b>	\$/MWh	<b>10.98 \$/MWh</b>
<b>O&amp;M Cost Notes</b>		
1. Fixed O&M costs include labor, materials and contracted services, and G&A costs. O&M costs exclude property taxes and insurance.		
2. Variable O&M costs include catalyst replacement, ammonia, limestone, water, ash disposal, FGD waste disposal, and water discharge treatment cost.		

### 3.4 ENVIRONMENTAL & EMISSIONS INFORMATION

The emissions for the major criteria pollutants are summarized in Table 3-3. The NO<sub>x</sub> emissions assume that the in-furnace controls such as LNB, OFA, and SCR systems are employed to control emissions to 0.06 lb/MMBtu. The WFGD system is assumed to be capable of 98% reduction of SO<sub>2</sub> from an inlet loading of 4.3 lb/MMBtu. The CO<sub>2</sub> emissions estimates are based on a 90% removal from the default CO<sub>2</sub> emissions factors listed in Table C-1 of 40 CFR 98, Subpart C.

Table 3-3 — Case 3 Emissions

<b>Case 3</b>		
<b>EIA – Emissions Rates</b>		
650 MW Net, Ultra-Supercritical Coal w/ 90% Carbon Capture		
<b>Predicted Emissions Rates (Note 1)</b>		
NO <sub>x</sub>	lb/MMBtu	0.06 (Note 2)
SO <sub>2</sub>	lb/MMBtu	0.09 (Note 3)
CO <sub>2</sub>	lb/MMBtu	20.6 (Note 4)
<b>Emissions Control Notes</b>		
1. High sulfur Bituminous Coal, 4.3 lb/MMBtu SO <sub>2</sub> Coal		
2. NO <sub>x</sub> Removal using LNBs with OFA, and SCR		
3. SO <sub>2</sub> Removal by Forced Oxidation, Limestone Based, Wet FGD, 98% Reduction		
4. 90% reduction from baseline Per 40 CFR 98, Subpt. C, Table C-1		



## **CASE 4. INTERNAL COMBUSTION ENGINES, 20 MW**

### **4.1 CASE DESCRIPTION**

This case is a reciprocating internal combustion engine (RICE) power plant based on four large-scale natural-gas-fired engines. Each engine is rated nominally at 5.6 MW with a net capacity of 21.4 MW. The configuration is selected to represent the installation of peaking or supplemental capacity for a municipality or small utility.

#### **4.1.1 Mechanical Equipment & Systems**

The RICE power plant comprises four gas-fired engines that are coupled to a generator. The power plant also includes the necessary engine auxiliary systems, which are fuel gas, lubricated oil, compressed air, cooling water, air intake, and exhaust gas.

Each engine is comprised of 10 cylinders in a V configuration. The engines are a four-stroke, spark-ignited, single fuel engine that operates on the Otto cycle. Each engine includes a turbocharger with an intercooler that uses the expansion of hot exhaust gases to drive a compressor that raises the pressure and density of the inlet air to each cylinder, leading to increased power output of the engine. Each engine is equipped with an SCR and carbon monoxide (CO) catalyst for emissions control.

The engines are cooled using a closed-loop cooling water system that circulates a water/glycol mixture through the engine block. Heat is rejected from the cooling water system by air-cooled radiators. A starting air system provides the high-pressure compressed air required to start the engine. An instrument air system is provided for standard instrumentation and plant air use.

#### **4.1.2 Electrical & Control Systems**

The electrical generator is coupled to the engine. The generator is a medium voltage, air-cooled, synchronous alternating current (AC) generator.

The engine original equipment manufacturer (OEM) provides a DCS that allows for a control interface, plant operating data, and historian functionality. The control system is in an onsite building. Programmable logic controllers are also provided throughout the plant for local operation.



### 4.1.3 Offsite Requirements

Natural gas is delivered to the facility through a gas connection at the site boundary. A natural gas line is routed from the nearest gas lateral to a gas metering station at the site boundary. The gas pressure is reduced as necessary to meet the requirements of the facility downstream of the metering station.

Since water consumption is minimal at the power plant, water is obtained from the municipal water supply. The power plant also includes minimal water treatment for onsite water usage. Wastewater is treated using an oil-water separator and then is directed to a municipal wastewater system. Used oil that is no longer filterable is stored in a waste oil tank and removed offsite with a vacuum truck.

The power plant's onsite switchyard is connected to the transmission system through a nearby substation.

## 4.2 CAPITAL COST ESTIMATE

The base cost estimate for this technology case totals \$1810/kW. Table 4-1 summarizes the cost components for this case.

**Table 4-1 — Case 4 Capital Cost Estimate**

<b>Case 4</b>		
<b>EIA – Capital Cost Estimates – 2019 \$s</b>		
<b>Configuration</b>	<b>Internal Combustion Engines</b>	
<b>Combustion Emissions Controls</b>	4 x 5.6 MW	
<b>Post-Combustion Emissions Controls</b>	None	
<b>Fuel Type</b>	SCR	
	Natural Gas	
<b>Units</b>		
<b>Plant Characteristics</b>		
Net Plant Capacity (60 deg F, 60% RH)	MW	21.4
Net Plant Heat Rate, HHV Basis	Btu/kWh	8295
<b>Capital Cost Assumptions</b>		
EPC Contracting Fee	% of Direct & Indirect Costs	10%
Project Contingency	% of Project Costs	8%
Owner's Services	% of Project Costs	7.5%
Estimated Land Requirement (acres)	\$	10
Estimated Land Cost (\$/acre)	\$	30,000
<b>Interconnection Costs</b>		
<i>Electrical Transmission Line Costs</i>		
Electrical Transmission Line Costs	\$/mile	720,000
Miles	miles	1.00
Substation Expansion	\$	0
<i>Gas Interconnection Costs</i>		
Pipeline Cost	\$/mile	100,000
Miles	miles	0.50
Metering Station	\$	75,000



<b>Case 4</b>			
<b>EIA – Capital Cost Estimates – 2019 \$\$</b>			
<b>Configuration</b>	<b>Internal Combustion Engines</b>		
	4 x 5.6 MW		
<b>Combustion Emissions Controls</b>	None		
<b>Post-Combustion Emissions Controls</b>	SCR		
<b>Fuel Type</b>	Natural Gas		
<b>Units</b>			
<i>Typical Project Timelines</i>			
Development, Permitting, Engineering	months		12
Plant Construction Time	months		18
Total Lead Time Before COD	months		30
Operating Life	years		30
<b>Cost Components (Note 1)</b>		<b>Breakout</b>	<b>Total</b>
<i>Civil/Structural/Architectural Subtotal</i>	\$		6,861,000
Engines (Note 3)	\$	11,974,000	
Mechanical BOP	\$	5,521,000	
<i>Mechanical Subtotal</i>	\$		17,495,000
<i>Electrical Subtotal</i>	\$		6,668,000
Project Indirects	\$		180,000
EPC Total Before Fee	\$		19,230,000
EPC Fee	\$		1,923,000
<b>EPC Subtotal</b>	<b>\$</b>		<b>21,153,000</b>
<b>Owner's Cost Components (Note 2)</b>			
Owner's Services	\$		1,586,000
Land	\$		300,000
Owner Furnished Equipment (Note 3)	\$		11,974,000
Electrical Interconnection	\$		720,000
Gas Interconnection	\$		125,000
<b>Owner's Cost Subtotal</b>	<b>\$</b>		<b>14,705,000</b>
<b>Project Contingency</b>	<b>\$</b>		<b>2,869,000</b>
<b>Total Capital Cost</b>	<b>\$</b>		<b>38,727,000</b>
<b>\$/kW net</b>			<b>1,810</b>
<b>Capital Cost Notes</b>			
<p>1. Costs based on EPC contracting approach. Direct costs include equipment, material, and labor to construct the civil/structural, mechanical, and electrical/I&amp;C components of the facility. Indirect costs include distributable material and labor costs, cranes, scaffolding, engineering, construction management, startup and commissioning, and contractor overhead. EPC fees are applied to the sum of direct and indirect costs.</p> <p>2. Owner's costs include project development, studies, permitting, legal, owner's project management, owner's engineering, and owner's startup and commissioning costs. Other owner's costs include electrical interconnection costs, gas interconnection costs (if applicable), and land acquisition costs.</p> <p>3. Engines and associated auxiliaries procured by Owner from the engine OEM.</p>			



### 4.3 O&M COST ESTIMATE

The O&M cost estimate includes all tasks discussed in the O&M estimate description.

**Table 4-2 — Case 4 O&M Cost Estimate**

<b>Case 4</b>		
<b>EIA – Non-Fuel O&amp;M Costs – 2019 \$s</b>		
Internal Combustion Engines		
<b>Fixed O&amp;M – Plant (Note 1)</b>		
Subtotal Fixed O&M	\$/kW-year	<b>35.16 \$/kW-year</b>
<b>Variable O&amp;M (Note 2)</b>	\$/MWh	<b>5.69 \$/MWh</b>
<b>O&amp;M Cost Notes</b>		
1. Fixed O&M costs include labor, materials and contracted services, and G&A costs. O&M costs exclude property taxes and insurance.		
2. Variable O&M costs include water, water discharge treatment cost, chemicals, and consumables.		

### 4.4 ENVIRONMENTAL & EMISSIONS INFORMATION

NO<sub>x</sub> and CO emissions are maintained through an SCR and CO catalyst installed in the exhaust system of each engine. SO<sub>2</sub> is uncontrolled but minimal and below emission limits because of the low amounts of SO<sub>2</sub> in the natural gas fuel. Water, wastewater, solid waste, and spent lubricating oil are disposed of through conventional means.

**Table 4-3 — Case 4 Emissions**

<b>Case 4</b>		
<b>EIA – Emissions Rates</b>		
Internal Combustion Engines		
<b>Predicted Emissions Rates – Natural Gas</b>		
NO <sub>x</sub>	lb/MMBtu	0.02 (Note 1)
SO <sub>2</sub>	lb/MMBtu	0.00
CO	lb/MMBtu	0.03
CO <sub>2</sub>	lb/MMBtu	117 (Note 2)
<b>Emissions Control Notes</b>		
1. With SCR		
2. Per 40 CFR98 Sub Part C – Table C1		

## CASE 5. COMBUSTION TURBINES AERODERIVATIVE, 100-MW SIMPLE CYCLE

### 5.1 CASE DESCRIPTION

This case is comprised of two duplicate aeroderivative CTs in simple-cycle configuration. It is based on natural gas firing of the CTs, although dual fuel capability is provided. Output power voltage is stepped up for transmission to the external grid through an onsite switchyard.

#### 5.1.1 Mechanical Equipment & Systems

Case 5 is comprised of a pair of aeroderivative dual fuel CTs in simple-cycle configuration, with a nominal output of 53.7 MW gross per turbine. After deducting internal auxiliary power demand, the net output of the plant is 105.1 MW. Each CT's inlet air duct has an evaporative cooler to reduce the inlet air temperature in warmer seasons to increase the CT output. Each CT is also equipped with burners designed to reduce the CT's emission of NO<sub>x</sub>. Not included in the Case 5 configuration are SCR units for further reduction of NO<sub>x</sub> emissions or CO catalysts for further reduction of CO emissions. Refer to Figure 5-1 for a diagram of the CT systems.

**Figure 5-1 — Case 2 Configuration**

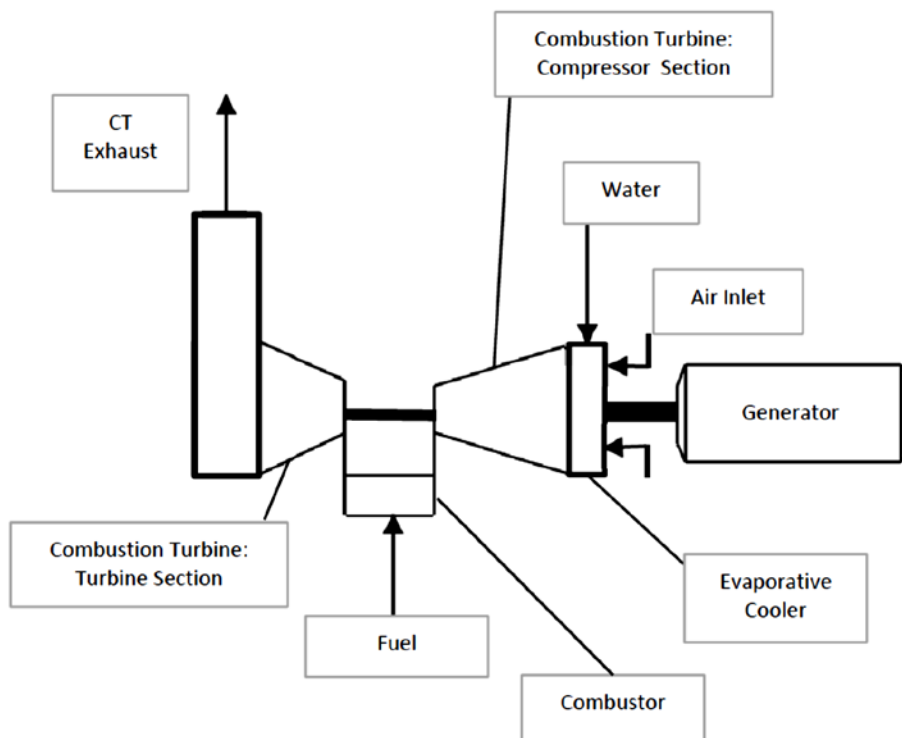

**Note:** Only one CT shown. Second CT has the same configuration.



Aeroderivative CTs differ from industrial frame CTs in that aeroderivative CTs have been adapted from an existing aircraft engine design for stationary power generation applications. Consequently, compared to industrial frame CTs of the same MW output, aeroderivative CTs are lighter weight, have a smaller size footprint, and have more advanced materials of construction. Additionally, aeroderivative CTs in general operate at higher pressure ratios, have faster start-up times and ramp rates, and higher efficiencies compared to industrial frame CTs.

### 5.1.2 Electrical & Control Systems

Case 5 includes one 60-hertz (Hz) electric generator per CT with an approximate rating of 54 MVA and output voltage of 13.8 kV. The generator output power is converted to a higher voltage by GSUs for transmission to the external grid transmitted via an onsite switchyard.

The simple-cycle facility is controlled by a control system provided by the CT manufacturer, supplemented by controls for the BOP systems (e.g., water supply to evaporative coolers, fuel supply).

### 5.1.3 Offsite Requirements

Offsite provisions in Case 5 include:

- **Fuel Gas Supply:** A half-mile-long pipeline and a dedicated metering station.
- **High-Voltage Transmission Line:** A one-mile long transmission line.
- **Water Supply for Evaporative Cooler and Miscellaneous Uses:** It is assumed that the water supply source, such as a municipal water system, is near the power plant site and the interconnection for water is at the plant's site boundary. Blowdown waste from the evaporative cooler is sent to an approved discharge location after appropriate treatment of the wastewater, and the wastewater interconnection's location is assumed at the power plant's site boundary.

## 5.2 CAPITAL COST ESTIMATE

The base cost estimate for this technology case totals \$1175/kW. Table 5-1 summarizes the cost components for this case. This estimate is based on an engineering, procurement, and construction (EPC) contracting approach.

In addition to EPC contract costs, the capital cost estimate in Table 5-1 covers owner's costs, which include project development, studies, permitting, and legal; owner's project management; owner's engineering; and owner's participation in startup and commissioning. The estimate is presented as an overnight cost in 2019 dollars and thus excludes Allowance for Funds Used During Construction or



interest during construction. In addition to the cost of external systems noted above (e.g., fuel gas supply and transmission line), an estimated amount is included for the cost of land.

**Table 5-1 — Case 5 Capital Cost Estimate**

<b>Case 5</b>		
<b>EIA – Capital Cost Estimates – 2019 \$s</b>		
<b>Configuration</b>	<b>Combustion Turbines – Simple Cycle</b>	
<b>Combustion Emissions Controls</b>	2 x Aeroderivative Class	
<b>Post-Combustion Emissions Controls</b>	Dry Low Emissions Combustor	
<b>Fuel Type</b>	None	
	Natural Gas / No. 2 Backup	
	2 x 54 MW rating	
<b>Units</b>		
<b>Plant Characteristics</b>		
Net Plant Capacity (60 deg F, 60% RH)	MW	105
Heat Rate, HHV Basis	Btu/kWh	9124
<b>Capital Cost Assumptions</b>		
EPC Contracting Fee	% of Direct & Indirect Costs	10%
Project Contingency	% of Project Costs	10%
Owner's Services	% of Project Costs	7%
Estimated Land Requirement (acres)	\$	20
Estimated Land Cost (\$/acre)	\$	30,000
<b>Interconnection Costs</b>		
<i>Electrical Transmission Line Costs</i>		
Electrical Transmission Line Costs	\$/mile	1,200,000
Miles	miles	1.00
Substation Expansion	\$	0
<i>Gas Interconnection Costs</i>		
Pipeline Cost	\$/mile	2,800,000
Miles	miles	0.50
Metering Station	\$	3,100,000
<b>Typical Project Timelines</b>		
Development, Permitting, Engineering	months	18
Plant Construction Time	months	22
Total Lead Time Before COD	months	40
Operating Life	years	40
<b>Cost Components (Note 1)</b>		<b>Breakout</b>
<i>Civil/Structural/Architectural Subtotal</i>		<b>Total</b>
	\$	6,300,000
Mechanical – Major Equipment	\$	43,400,000
Mechanical – Balance of Plant	\$	9,900,000
<i>Mechanical Subtotal</i>	\$	53,300,000
<i>Electrical Subtotal</i>	\$	15,400,000
Project Indirects	\$	15,000,000
EPC Total Before Fee	\$	90,000,000
EPC Fee	\$	9,000,000
<b>EPC Subtotal</b>	<b>\$</b>	<b>99,000,000</b>
<b>Owner's Cost Components (Note 2)</b>		
Owner's Services	\$	6,930,000
Land	\$	600,000
Electrical Interconnection	\$	1,200,000
Gas Interconnection	\$	4,500,000





<b>Case 5</b>	
<b>EIA – Capital Cost Estimates – 2019 \$s</b>	
<b>Configuration</b>	<b>Combustion Turbines – Simple Cycle</b>
<b>Combustion Emissions Controls</b>	2 x Aeroderivative Class
<b>Post-Combustion Emissions Controls</b>	Dry Low Emissions Combustor
<b>Fuel Type</b>	None
	Natural Gas / No. 2 Backup
	2 x 54 MW rating
	<b>Units</b>
<b>Owner's Cost Subtotal</b>	\$ 13,230,000
<b>Project Contingency</b>	\$ 11,223,000
<b>Total Capital Cost</b>	\$ 123,453,000
	<b>\$/kW net 1,175</b>
<b>Capital Cost Notes</b>	
<p>1. Costs based on EPC contracting approach. Direct costs include equipment, material, and labor to construct the civil/structural, mechanical, and electrical/I&amp;C components of the facility. Indirect costs include distributable material and labor costs, cranes, scaffolding, engineering, construction management, startup and commissioning, and contractor overhead. EPC fees are applied to the sum of direct and indirect costs.</p> <p>2. Owner's costs include project development, studies, permitting, legal, owner's project management, owner's engineering, and owner's startup and commissioning costs. Other owner's costs include electrical interconnection costs, gas interconnection costs (if applicable), and land acquisition costs.</p>	

### 5.3 O&M COST ESTIMATE

Table 5-2 shows O&M costs. Fixed O&M costs include staff and administrative costs, supplies, and minor routine maintenance. (Not included are property taxes and insurance.) Fixed costs also include the fixed payment portion of a long-term service agreement for the CTs.

Variable O&M costs include consumable commodities, such as water, lubricants, and chemicals. Also included is the average annual cost of the planned maintenance events for the CTs over the long-term maintenance cycle, based on the number of equivalent operating hours (EOH) the CT has run. A significant overhaul is typically performed for this type of CT every 25,000 EOH, and a major overhaul is performed every 50,000 EOH. (CTs generally have two criteria to schedule overhauls: number of equivalent starts and number of EOH. The aeroderivative CTs in Case 5 always use an EOH-driven maintenance overhaul schedule regardless of the operating profile. Refer to Case 6 for a starts-based overhaul schedule.) An additional advantage of an aeroderivative CTs is that, depending on the long-term service agreement terms, sections of the CT can be changed out with replacement assemblies, reducing the outage time of major overhauls to less than one week (compared to more than a two-week outage for industrial frame CTs).



**Table 5-2 — Case 5 O&M Cost Estimate**

<b>Case 5</b>		
<b>EIA – Non-Fuel O&amp;M Costs – 2019 \$s</b>		
Combustion Turbine – Simple Cycle		
<b>Fixed O&amp;M – Plant (Note 1)</b>		
Subtotal Fixed O&M	\$/kW-year	<b>16.30 \$/kW-year</b>
<b>Variable O&amp;M (Note 2)</b>	\$/MWh	<b>4.70 \$/MWh</b>
<b>O&amp;M Cost Notes</b>		
1. Fixed O&M costs include labor, materials and contracted services, and G&A costs. O&M costs exclude property taxes and insurance.		
2. Variable O&M costs include water and water discharge treatment cost. They are based on a number operating hours-based regimen.		

## 5.4 ENVIRONMENTAL & EMISSIONS INFORMATION

For the Case 5 simple-cycle configuration, NO<sub>x</sub> emissions from the CT stacks when firing gas are indicated in Table 5-3. Although some locations in the United States would require SCRs and CO catalysts to further reduce stack emissions, SCRs and CO catalysts have not been included for Case 5.

**Table 5-3 — Case 5 Emissions**

<b>Case 5</b>		
<b>EIA – Emissions Rates</b>		
Combustion Turbine – Simple Cycle		
<b>Predicted Emissions Rates (Note 1)</b>		
NO <sub>x</sub>	lb/MMBtu	0.09
SO <sub>2</sub>	lb/MMBtu	0.00
CO <sub>2</sub>	lb/MMBtu	117
<b>Emissions Control Notes</b>		
1. Natural Gas, no water injection		

## CASE 6. COMBUSTION TURBINE F CLASS, 240-MW SIMPLE CYCLE

### 6.1 CASE DESCRIPTION

This case is comprised of one industrial frame Model F CT in simple-cycle configuration. It is based on natural gas firing of the CT, although dual fuel capability is provided. Output power voltage is stepped up for transmission to the external grid through an onsite switchyard.

#### 6.1.1 Mechanical Equipment & Systems

Case 6 is comprised of one industrial frame Model F dual fuel CT in simple-cycle configuration with a nominal output of 237.2 MW gross. After deducting internal auxiliary power demand, the net output of the plant is 232.6 MW. The inlet air duct for the CT is equipped with an evaporative cooler to reduce the inlet air temperature in warmer seasons to increase the CT output. The CT is also equipped with burners designed to reduce the CT's emission of NO<sub>x</sub>. Not included in the Case 6 configuration is an SCR unit for further reduction of NO<sub>x</sub> emissions or a CO catalyst for further reduction of CO emissions. Figure 6-1 shows a diagram of the CT systems.

Figure 6-1 — Case 6 Configuration

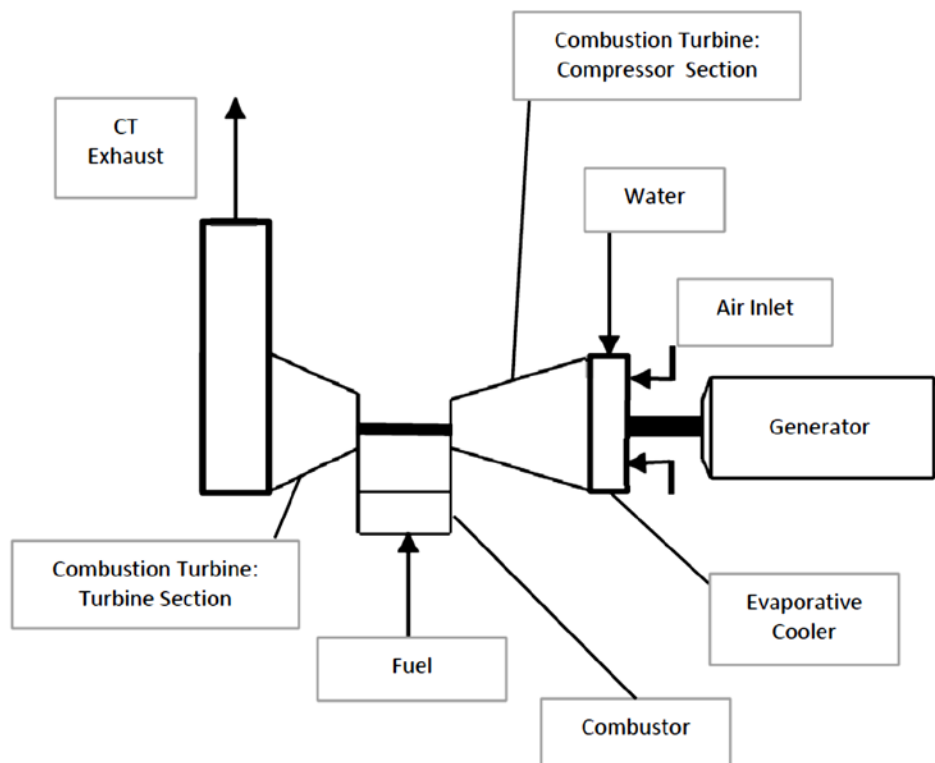



Frame CTs differ from aeroderivative CTs in that the industrial frame CT's performance characteristics generally are more conducive to improved performance in CC applications; that is, industrial frame CTs have a greater amount of exhaust energy to produce steam for the CC's steam turbine portion of the plant. Industrial frame CT sizes, over 400 MW in 60-Hz models, far exceed the maximum aeroderivative size, and on a \$/kW basis, industrial frame turbines are less costly.

### 6.1.2 Electrical & Control Systems

Case 6 includes one 60-Hz CT electric generator with an approximate rating of 240 MVA and output voltage of 13.8 kV. The generator output power is converted to a higher voltage by GSUs for transmission to the external grid, transmitted through an onsite facility switchyard.

The simple-cycle facility is controlled by a control system provided by the CT manufacturer, supplemented by controls for the BOP systems (e.g., water supply to evaporative coolers, fuel supply)

### 6.1.3 Offsite Requirements

Offsite provisions in Case 6 include:

- **Fuel Gas Supply:** A half-mile-long pipeline and a dedicated metering station.
- **High-Voltage Transmission Line:** A one-mile long transmission line.
- **Water Supply for Evaporative Cooler and Miscellaneous Uses:** It is assumed that the water supply source, such as a municipal water system, is near the power plant site and the interconnection for water is at the plant's site boundary. Blowdown waste from the evaporative cooler is sent to an approved discharge location after appropriate treatment of the wastewater, and the wastewater interconnection is assumed at the power plant's site boundary.

## 6.2 CAPITAL COST ESTIMATE

The base cost estimate for this technology case totals \$713/kW. Table 6-1 summarizes the cost components for this case. This estimate is based on an EPC contracting approach.

In addition to EPC contract costs, the capital cost estimate in Table 6-1 covers owner's costs, which include project development, studies, permitting, and legal; owner's project management; owner's engineering; and owner's participation in startup and commissioning. The estimate is presented as an overnight cost in 2019 dollars and thus excludes Allowance for Funds Used During Construction or interest during construction. In addition to the cost of external systems noted above (e.g., fuel gas supply), an estimated amount is included for the cost of land.



Table 6-1 — Case 6 Capital Cost Estimate

Case 6 EIA – Capital Cost Estimates – 2019 \$s			
<b>Configuration</b>	<b>Combustion Turbine – Simple Cycle</b>		
<b>Combustion Emissions Controls</b>	F-Class		
<b>Post-Combustion Emissions Controls</b>	Dry Low Emissions Combustor		
<b>Fuel Type</b>	None		
	Natural Gas / No. 2 Backup		
	1 x 237 MW rating		
<b>Units</b>			
<b>Plant Characteristics</b>			
Net Plant Capacity (60 deg F, 60% RH)	MW		233
Heat Rate, HHV Basis	Btu/kWh		9905
<b>Capital Cost Assumptions</b>			
EPC Contracting Fee	% of Direct & Indirect Costs		10%
Project Contingency	% of Project Costs		10%
Owner's Services	% of Project Costs		7%
Estimated Land Requirement (acres)	\$		20
Estimated Land Cost (\$/acre)	\$		30,000
<b>Interconnection Costs</b>			
<b>Electrical Transmission Line Costs</b>	\$/mile		1,200,000
Miles	miles		1.00
Substation Expansion	\$		0
<b>Gas Interconnection Costs</b>			
Pipeline Cost	\$/mile		2,800,000
Miles	miles		0.50
Metering Station	\$		3,100,000
<b>Typical Project Timelines</b>			
Development, Permitting, Engineering	months		18
Plant Construction Time	months		22
Total Lead Time Before COD	months		40
Operating Life	years		40
<b>Cost Components (Note 1)</b>		<b>Breakout</b>	<b>Total</b>
<i>Civil/Structural/Architectural Subtotal</i>	\$		12,300,000
Mechanical – Major Equipment	\$	54,000,000	
Mechanical – Balance of Plant	\$	17,200,000	
<i>Mechanical Subtotal</i>	\$		71,200,000
<i>Electrical Subtotal</i>	\$		20,200,000
Project Indirects	\$		19,000,000
EPC Total Before Fee	\$		122,700,000
EPC Fee	\$		12,270,000
<b>EPC Subtotal</b>	\$		134,970,000
<b>Owner's Cost Components (Note 2)</b>			
Owner's Services	\$		9,448,000
Land	\$		600,000
Electrical Interconnection	\$		1,200,000
Gas Interconnection	\$		4,500,000
<b>Owner's Cost Subtotal</b>	\$		15,748,000
<b>Project Contingency</b>	\$		15,072,000
<b>Total Capital Cost</b>	\$		165,790,000
	<b>\$/kW net</b>		<b>713</b>



<b>Case 6</b>	
<b>EIA – Capital Cost Estimates – 2019 \$\$</b>	
<b>Configuration</b>	<b>Combustion Turbine – Simple Cycle</b>
<b>Combustion Emissions Controls</b>	F-Class
<b>Post-Combustion Emissions Controls</b>	Dry Low Emissions Combustor
<b>Fuel Type</b>	None
<b>Capital Cost Notes</b>	Natural Gas / No. 2 Backup 1 x 237 MW rating
<p>1. Costs based on EPC contracting approach. Direct costs include equipment, material, and labor to construct the civil/structural, mechanical, and electrical/I&amp;C components of the facility. Indirect costs include distributable material and labor costs, cranes, scaffolding, engineering, construction management, startup and commissioning, and contractor overhead. EPC fees are applied to the sum of direct and indirect costs.</p> <p>2. Owner's costs include project development, studies, permitting, legal, owner's project management, owner's engineering, and owner's startup and commissioning costs. Other owner's costs include electrical interconnection costs, gas interconnection costs (if applicable), and land acquisition costs.</p>	

### 6.3 O&M COST ESTIMATE

Operation and maintenance costs are indicated in Table 6-2. Fixed O&M costs include staff and administrative costs, supplies, and minor routine maintenance. (Not included are property taxes and insurance.) Fixed costs also include the fixed payment portion of a long-term service agreement for the CT.

Variable O&M costs include consumable commodities, such as water, lubricants, and chemicals. Also included is the average annual cost of the planned maintenance events for the CT over the long-term maintenance cycle. Planned maintenance costs for the CT in a given year are based on the number of equivalent starts the CT has accumulated. A significant overhaul is performed for this type of CT every 900 equivalent starts, and a major overhaul is performed every 2,400 equivalent starts. (CTs generally have two criteria to schedule overhauls: number of equivalent starts and number of EOH. In Case 6, it is assumed the operating profile results in a starts-driven maintenance overhaul schedule. Refer to Case 5 for an EOH-based overhaul schedule.) In Table 6-2, the cost per start is broken out from the variable O&M costs that cover the consumables.

**Table 6-2 — Case 6 O&M Cost Estimate**

<b>Case 6</b>		
<b>EIA – Non-Fuel O&amp;M Costs – 2019 \$\$</b>		
Combustion Turbine – Simple Cycle		
<b>Fixed O&amp;M – Plant (Note 1)</b>		
Subtotal Fixed O&M	\$/kW-year	<b>7.00 \$/kW-year</b>
<b>Variable O&amp;M</b>		
Consumables, etc. (Note 2)	\$/MWh	<b>0.60 \$/MWh</b>
CT Major Maintenance (Note 2)	\$/Start	<b>\$18,500/Start</b>
<b>O&amp;M Cost Notes</b>		
1. Fixed O&M costs include labor, materials and contracted services, and G&A costs. O&M costs exclude property taxes and insurance.		
2. Variable O&M consumables costs include water, water discharge treatment cost, etc. based on \$/MWh. In addition to the Consumables VOM, add CT Major Maintenance VOM costs, which are based on a starts operating regime, with cost per start indicated.		

## 6.4 ENVIRONMENTAL & EMISSIONS INFORMATION

For the Case 6 simple-cycle configuration, NO<sub>x</sub> emissions from the CT stack when firing gas are indicated in Table 6-3. Although some locations in the United States would require SCRs and CO catalysts to further reduce stack emissions, an SCR and a CO catalyst have not been included for Case 6.

**Table 6-3 — Case 6 Emissions**

<b>Case 6</b>		
<b>EIA – Emissions Rates</b>		
Combustion Turbine – Simple Cycle		
<b>Predicted Emissions Rates (Note 1)</b>		
NO <sub>x</sub>	lb/MMBtu	0.030
SO <sub>2</sub>	lb/MMBtu	0.00
CO <sub>2</sub>	lb/MMBtu	117
<b>Emissions Control Notes</b>		
1. Natural Gas, no water injection		



## **CASE 7. COMBUSTION TURBINE H CLASS, 1100-MW COMBINED CYCLE**

### **7.1 CASE DESCRIPTION**

This case is comprised of one block of a CC power generation unit in a 2x2x1 configuration. The plant includes two industrial frame Model H “advanced technology” CTs and one STG. Case 7 is based on natural gas firing of the CTs, although dual fuel capability is provided. Main plant cooling is accomplished with a wet cooling tower system. Output power voltage is stepped up for transmission to the external grid through an onsite switchyard.

#### **7.1.1 Mechanical Equipment & Systems**

Case 7 is comprised of a pair of Model H, dual fuel CTs in a 2x2x1 CC configuration (two CTs, two heat recovery steam generators [HRSGs], and one steam turbine) with a nominal output for the CC plant of 1114.7-MW gross. Each CT generates 385.2 MW gross; the STG generates 344.3 MW gross. After deducting internal auxiliary power demand, the net output of the plant is 1083.3 MW. Refer to Figure 7-1 for a diagram of the Case 7 configuration.

Each CT’s inlet air duct has an evaporative cooler to reduce the inlet air temperature in warmer seasons to increase the CT and plant output. Each CT is also equipped with burners designed to reduce NO<sub>x</sub> emissions. Included in the Case 7 configuration are SCR units for further NO<sub>x</sub> emissions reduction and CO catalysts for further CO emissions reduction.

The CTs are Model H industrial frame type CTs with an advanced technology design, since they incorporate the following features:

- High firing temperatures (~2900°F)
- Advanced materials of construction
- Advanced thermal barrier coatings
- Additional cooling of CT assemblies (depending on the CT model, additional cooling applies to the CT rotor, turbine section vanes, and the combustor). Refer to Figure 7-1, which depicts a dedicated additional cooler for the CT assemblies in Case 7.

The high firing temperature and additional features listed above result in increased MW output and efficiency of the CT as well as in the CC plant.



Hot exhaust gas from each CT is directed to a HRSG, with one HRSG per CT. Steam generated in the HRSGs is directed to the STG. HRSGs may be optionally equipped with additional supplemental firing, however, this feature is not included in Case 7. (Supplemental HRSG firing, while increasing the MW output of the STG, reduces plant efficiency.)

A wet cooling tower system provides plant cooling for Case 7. A wet cooling tower is preferred over the alternative ACC approach since plant performance is better (i.e., greater MW output and higher efficiency) and capital cost is generally lower. However, ACCs are often selected in areas where the supply of makeup water needed for a wet cooling tower is scarce or expensive, such as in desert areas in the southwestern United States.

Figure 7-1 — Case 7 Configuration

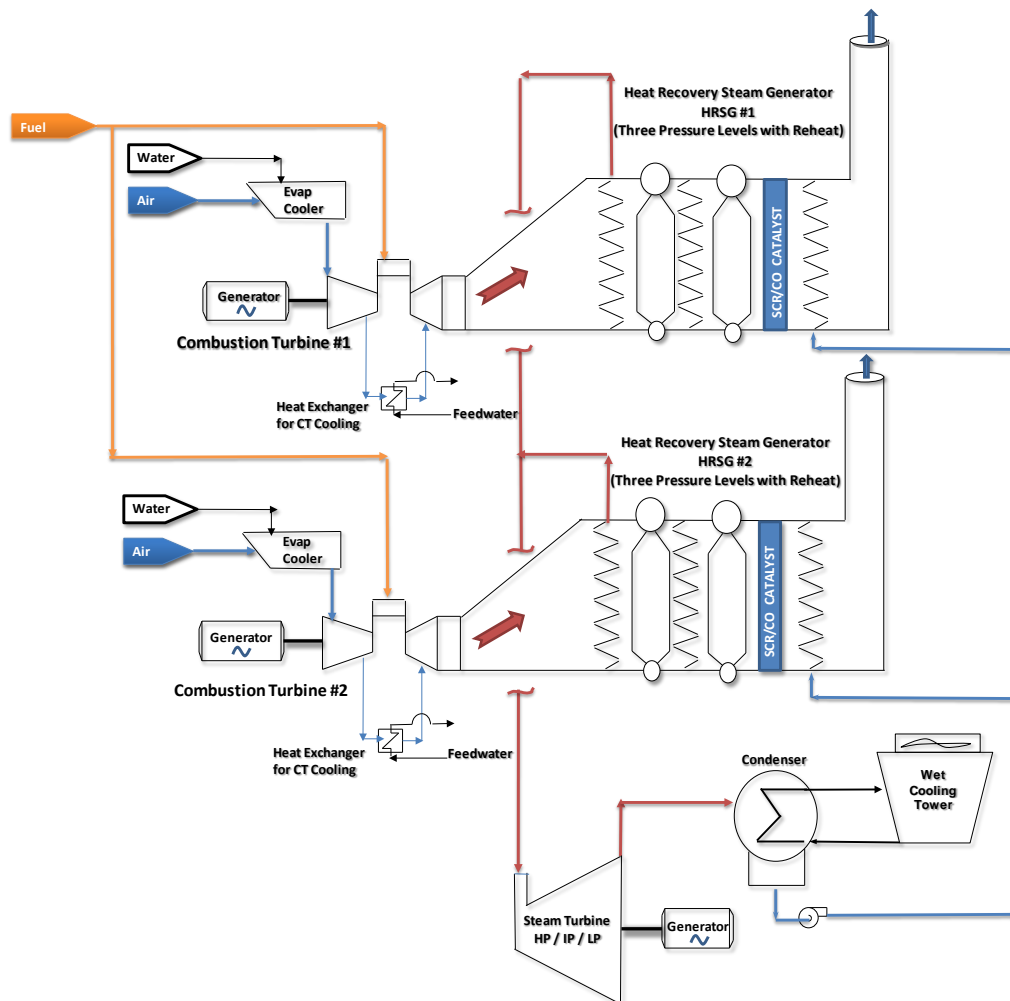



### 7.1.2 Electrical & Control Systems

Case 7 includes one 60-Hz electric generator per CT with an approximate rating of 390 megavolt amperes (MVA) and output voltage of 13.8 kV. The STG includes one 60-Hz electric generator with an approximate 350-MVA rating. The output power from the three generators is converted to a higher voltage by GSUs for transmission to the external grid, transmitted through an onsite facility switchyard.

The CC facility is controlled by a central DCS, which is linked to a CT control system provided by the CT manufacturer. This DCS includes controls for the steam cycle systems and equipment as well as BOP systems and equipment (e.g., water systems, fuel systems, main cooling systems).

### 7.1.3 Offsite Requirements

Offsite provisions in Case 7 include:

- **Fuel Gas Supply:** A half-mile-long pipeline and a dedicated metering station.
- **High-Voltage Transmission Line:** A one-mile long transmission line.
- **Water Supply for Cooling Tower, Evaporative Coolers, Makeup to Steam Cycle, and Miscellaneous Uses:** It is assumed that the water supply source is near the power plant site and the interconnection for water is at the plant's site boundary. Blowdown waste from the cooling tower and other areas of the plant is sent to an approved discharge location after appropriate treatment of the wastewater, and the wastewater interconnection is assumed to be located at the power plant's site boundary.

## 7.2 CAPITAL COST ESTIMATE

The base cost estimate for this technology case totals \$958/kW. Table 7-1 summarizes the cost components for this case. This estimate is based on an EPC contracting approach.

In addition to EPC contract costs, the capital cost estimate in Table 7-1 covers owner's costs, which include project development, studies, permitting, and legal; owner's project management; owner's engineering; and owner's participation in startup and commissioning. The estimate is presented as an overnight cost in 2019 dollars and thus excludes Allowance for Funds Used During Construction or interest during construction. In addition to the cost of external systems noted above (e.g., fuel gas supply and transmission line), an estimated amount is included for the cost of land.



Table 7-1 — Case 7 Capital Cost Estimate

<b>Case 7</b>		
<b>EIA – Capital Cost Estimates – 2019 \$\$</b>		
<b>Configuration</b>	<b>Combined Cycle 2x2x1</b>	
<b>Combustion Emissions Controls</b>	H-Class Dry Low NOx combustor with axial fuel staging	
<b>Post-Combustion Emissions Controls</b>	SCR Catalyst, CO Catalyst	
<b>Fuel Type</b>	Natural gas / No. 2 Backup	
<b>Post Firing</b>	No Post Firing	
<b>Units</b>		
<b>Plant Characteristics</b>		
Net Plant Capacity (60 deg F, 60% RH)	MW	1083
Net Plant Heat Rate, HHV Basis	Btu/kWh	6370
<b>Capital Cost Assumptions</b>		
EPC Contracting Fee	% of Direct & Indirect Costs	10%
Project Contingency	% of Project Costs	10%
Owner's Services	% of Project Costs	7%
Estimated Land Requirement (acres)	\$	60
Estimated Land Cost (\$/acre)	\$	30,000
<b>Interconnection Costs</b>		
<b>Electrical Transmission Line Costs</b>	\$/mile	2,520,000
Miles	miles	1.00
Substation Expansion	\$	0
<b>Gas Interconnection Costs</b>		
Pipeline Cost	\$/mile	2,800,000
Miles	miles	0.50
Metering Station	\$	4,500,000
<b>Typical Project Timelines</b>		
Development, Permitting, Engineering	months	18
Plant Construction Time	months	24
Total Lead Time Before COD	months	42
Operating Life	years	40
<b>Cost Components (Note 1)</b>		<b>Breakout</b>
<b>Civil/Structural/Architectural Subtotal</b>	\$	<b>60,000,000</b>
Mechanical – Major Equipment	\$	294,000,000
Mechanical – Balance of Plant	\$	196,000,000
<b>Mechanical Subtotal</b>	\$	<b>490,000,000</b>
<b>Electrical Subtotal</b>	\$	<b>93,000,000</b>
Project Indirects	\$	150,000,000
EPC Total Before Fee	\$	793,000,000
EPC Fee	\$	79,300,000
<b>EPC Subtotal</b>	\$	<b>872,300,000</b>
<b>Owner's Cost Components (Note 2)</b>		
Owner's Services	\$	61,061,000
Land	\$	1,800,000
Electrical Interconnection	\$	2,520,000
Gas Interconnection	\$	5,900,000
<b>Owner's Cost Subtotal</b>	\$	<b>71,281,000</b>
<b>Project Contingency</b>	\$	<b>94,358,000</b>
<b>Total Capital Cost</b>	\$	<b>1,037,939,000</b>
<b>\$/kW net</b>		<b>958</b>



<b>Case 7</b>	
<b>EIA – Capital Cost Estimates – 2019 \$\$</b>	
<b>Configuration</b>	<b>Combined Cycle 2x2x1</b>
<b>Combustion Emissions Controls</b>	H-Class Dry Low NOx combustor with axial fuel staging
<b>Post-Combustion Emissions Controls</b>	SCR Catalyst, CO Catalyst
<b>Fuel Type</b>	Natural gas / No. 2 Backup
<b>Post Firing</b>	No Post Firing
<b>Capital Cost Notes</b>	
<p>1. Costs based on EPC contracting approach. Direct costs include equipment, material, and labor to construct the civil/structural, mechanical, and electrical/I&amp;C components of the facility. Indirect costs include distributable material and labor costs, cranes, scaffolding, engineering, construction management, startup and commissioning, and contractor overhead. EPC fees are applied to the sum of direct and indirect costs.</p> <p>2. Owner's costs include project development, studies, permitting, legal, owner's project management, owner's engineering, and owner's startup and commissioning costs. Other owner's costs include electrical interconnection costs, gas interconnection costs (if applicable), and land acquisition costs.</p>	

### 7.3 O&M COST ESTIMATE

Table 7-2 indicates O&M costs. Fixed O&M costs include staff and administrative costs, supplies, and minor routine maintenance. (Not included are property taxes and insurance.) Fixed costs also include the fixed payment portion of a long-term service agreement for the CTs. Additional O&M costs for firm gas transportation service are not included as the facility has dual-fuel capability.

Variable O&M costs include consumable commodities, such as water, lubricants, and chemicals. It also includes the periodic costs to change out the SCR and CO catalysts. The variable O&M costs also include the average annual cost of the planned maintenance events for the CTs and the STG over the long-term maintenance cycle. Planned maintenance costs for the CTs in a given year are based on the number of EOH the CT has run. Typically, a significant overhaul is performed for this type of CT every 25,000 EOH, and a major overhaul is performed every 50,000 EOH. (CTs generally have two criteria to schedule overhauls: number of equivalent starts and number of EOH. Case 7 assumes the operating profile results in an EOH-driven maintenance overhaul schedule. Refer to Case 6 for a starts-based overhaul schedule.) Planned major outage work on the STG is scheduled less frequently than the CTs, typically planned for every six to eight years.



**Table 7-2 — Case 7 O&M Cost Estimate**

<b>Case 7</b>		
<b>EIA – Non-Fuel O&amp;M Costs – 2019 \$\$</b>		
Combined Cycle 2x2x1		
<b>Fixed O&amp;M – Plant (Note 1)</b>		
Subtotal Fixed O&M	\$/kW-year	<b>12.20 \$/kW-year</b>
<b>Variable O&amp;M (Note 2)</b>		
	\$/MWh	<b>1.87 \$/MWh</b>
<b>O&amp;M Cost Notes</b>		
1. Fixed O&M costs include labor, materials and contracted services, and G&A costs. O&M costs exclude property taxes and insurance.		
2. Variable O&M costs include catalyst replacement, ammonia, water, and water discharge treatment cost.		

## 7.4 ENVIRONMENTAL & EMISSIONS INFORMATION

For the Case 7 CC configuration, NO<sub>x</sub> emissions from the HRSG stacks when firing gas are indicated in Table 7-3. SCRs and CO catalysts are included in the HRSGs to reduce HRSG stack emissions of NO<sub>x</sub> and CO below the emission levels in the CT exhaust gas.

**Table 7-3 — Case 7 Emissions**

<b>Case 7</b>		
<b>EIA – Emissions Rates</b>		
Combined Cycle 2x2x1		
<b>Predicted Emissions Rates (Note 1)</b>		
NO <sub>x</sub>	lb/MMBtu	0.0075
SO <sub>2</sub>	lb/MMBtu	0.001
CO <sub>2</sub>	lb/MMBtu	117
<b>Emissions Control Notes</b>		
1. Natural Gas, no water injection		



## **CASE 8. COMBUSTION TURBINE H CLASS, COMBINED-CYCLE SINGLE SHAFT, 430 MW**

### **8.1 CASE DESCRIPTION**

This case is comprised of one block of a combined-cycle power generation unit. The plant includes one industrial frame Model H “advanced technology” CT, one STG, and one electric generator that is common to the CT and the STG. Case 8 is based on natural gas firing of the CT, although dual fuel capability is provided. Main plant cooling is accomplished with a wet cooling tower system. Output power voltage is stepped up for transmission to the external grid through an onsite switchyard.

#### **8.1.1 Mechanical Equipment & Systems**

Case 8 is comprised of one Model H dual fuel CT in a 1x1x1 single-shaft CC configuration with a nominal output for the CC plant of 430.4 MW gross. The CT generates 297.2 MW gross and the STG generates 133.2 MW gross. After deducting internal auxiliary power demand, the net output of the plant is 418.3 MW. Refer to Figure 8-1 for a diagram of the Case 8 process, which is similar to Case 7.

The Case 8 layout differs from Case 7 in that Case 8 is a single-shaft CC plant. That is, the Case 8 CT, STG, and electric generator all share one horizontal shaft. Therefore, it has a more compact footprint than a plant like Case 7, where the CTs and STG have separate shafts and generators. Refer to Figure 8-2 for a simplified sketch of a single shaft CT/steam turbine/generator unit. Generally, there are no major performance advantages of a single-shaft CC unit. Instead, the advantages are in costs; that is, in the case of a 1x1x1 CC, the single-shaft unit will have only one electric generator whereas a multiple shaft 1x1x1 CC will have two generators. Also, the smaller footprint of the single-shaft unit will lessen BOP costs such as foundations, piping, and cabling costs.

The inlet air duct for the CT is equipped with an evaporative cooler to reduce the inlet air temperature in warmer seasons to increase the CT and plant output. The CT is also equipped with burners designed to reduce the CT’s emission of NO<sub>x</sub>. Included in the Case 8 configuration is an SCR unit for further reduction of NO<sub>x</sub> emissions and a CO catalyst for further reduction of CO emissions.

The CT is categorized as Model H industrial frame type CT with an advanced technology design since it incorporates in the design the following features:

- High-firing temperatures (~2900°F)
- Advanced materials of construction



- Advanced thermal barrier coatings
- Additional cooling of CT assemblies (depending on the CT model, additional cooling applies to the CT rotor, turbine section vanes, and the combustor). Refer to Figure 8-1, which depicts a dedicated additional cooler for the CT assemblies in Case 8.

The high-firing temperature and additional features listed above result in an increase in MW output and efficiency of the CT as well as in the CC plant.

Hot exhaust gas from the CT is directed to a HRSG. Steam generated in the HRSG is directed to the STG. An HRSG may be optionally equipped with additional supplemental firing, but this feature is not included in Case 8. (Supplemental HRSG firing, while increasing the MW output of the STG, reduces plant efficiency.)

Plant cooling for Case 8 is provided by a wet cooling tower system. Generally, a wet cooling tower is preferred over the alternative ACC approach since plant performance is better (i.e., greater MW output and higher efficiency) with a wet tower and capital cost is generally lower. However, ACCs are often selected in areas where the supply of makeup water needed for a wet cooling tower is scarce or expensive, such as in desert areas in the southwestern United States.



Figure 8-1 — Case 8 Configuration – Process Diagram

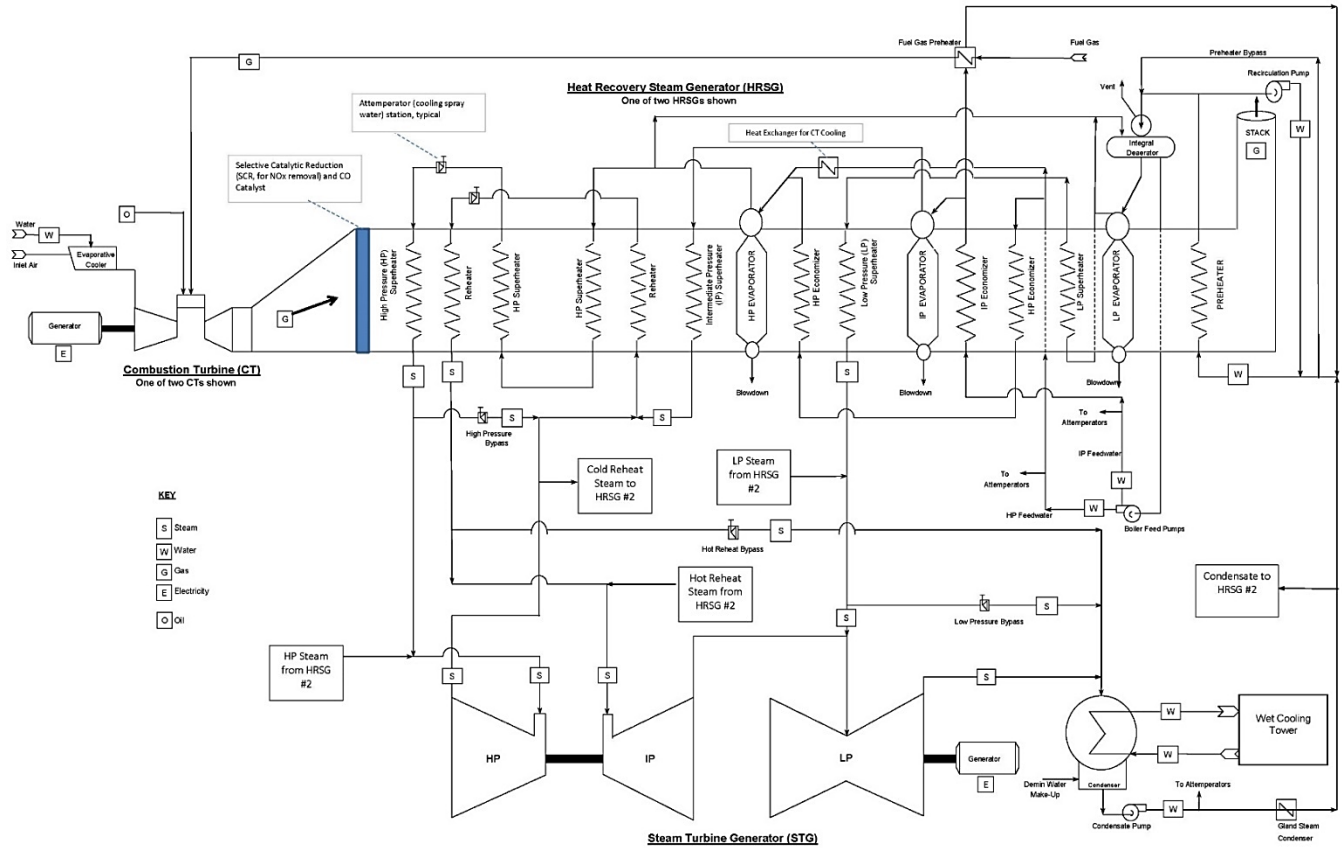

**Note:** Only one CT and one HRSG shown. Second CT and HRSG have the same configurations.



Figure 8-2 — Case 8 Configuration – Simplified Sketch

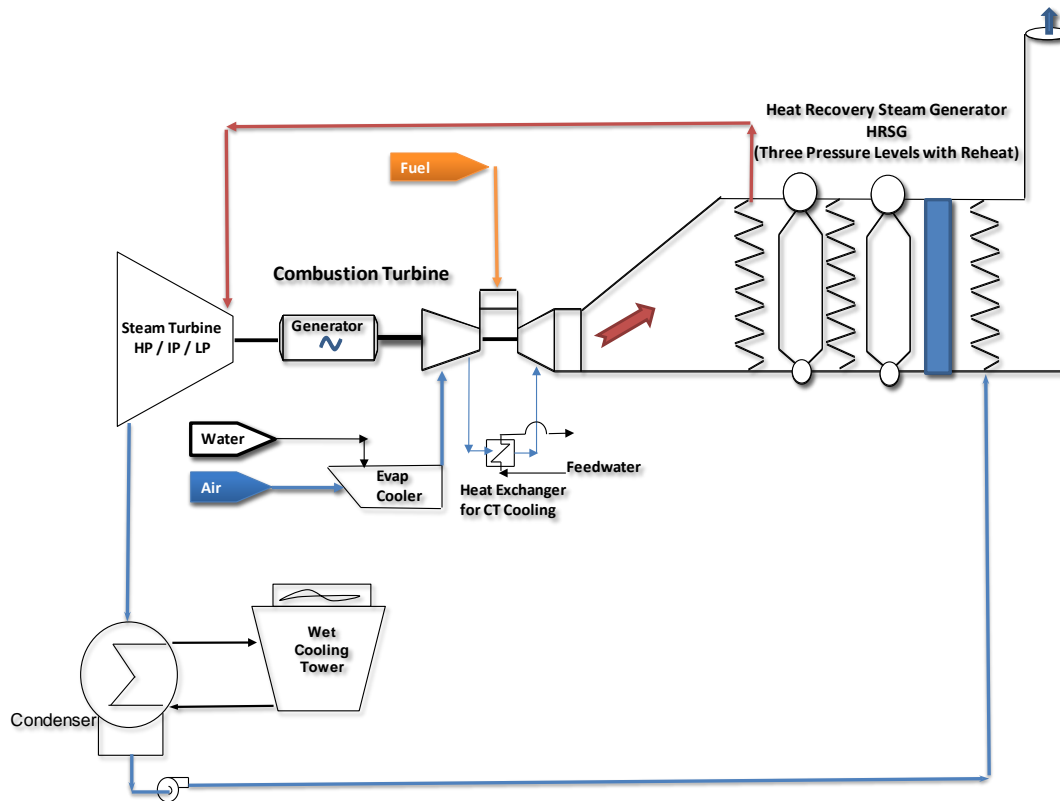

Conceptual sketch of a 1x1x1 single-shaft CT/steam turbine/generator plant

### 8.1.2 Electrical & Control Systems

Case 8 includes one 60-Hz electric generator for both the CT and steam turbine, with an approximate rating of 435 MVA and output voltage of 13.8 kV. The output power from the generator is converted to a higher voltage by a GSU for transmission to the external grid, transmitted through an onsite facility switchyard.

The CC facility is controlled by a central DCS, which is linked to a CT control system provided by the CT manufacturer. The DCS system includes controls for the steam cycle systems and equipment as well as the BOP systems and equipment (e.g., water systems, fuel systems, main cooling systems).

### 8.1.3 Offsite Requirements

Offsite provisions in Case 8 include:

- **Fuel Gas Supply:** A half-mile-long pipeline and a dedicated metering station.



- **High-Voltage Transmission Line:** A one-mile long transmission line.
- **Water Supply for Cooling Tower, Evaporative Coolers, Makeup to Steam Cycle, and Miscellaneous Uses:** It is assumed that the water supply source is near the power plant site and the interconnection for water is at the plant's site boundary. Blowdown waste from the cooling tower and other areas of the plant is sent to an approved discharge location after appropriate treatment of the wastewater, and the wastewater interconnection is assumed to be located at the power plant's site boundary.

## 8.2 CAPITAL COST ESTIMATE

The base cost estimate for this technology case totals \$1084/kW. Table 8-1 summarizes the cost components for this case. The capital cost estimate is based on an EPC contracting approach.

In addition to EPC contract costs, the capital cost estimate in Table 8-1 covers owner's costs, which include project development, studies, permitting, and legal; owner's project management; owner's engineering; and owner's participation in startup and commissioning. The estimate is presented as an overnight cost in 2019 dollars and thus excludes Allowance for Funds Used During Construction or interest during construction. In addition to the cost of external systems noted above (e.g., fuel gas supply and transmission line), an estimated amount is included for the cost of land.

**Table 8-1 — Case 8 Capital Cost Estimate**

Case 8 EIA – Capital Cost Estimates – 2019 \$s		
Configuration	Combined Cycle 1x1x1, Single Shaft H Class	
Combustion Emissions Controls	Dry Low NOx combustor with axial fuel staging	
Post-Combustion Emissions Controls	SCR Catalyst, CO Catalyst	
Fuel Type	Natural Gas / No. 2 Backup	
Post Firing	No Post Firing	
<b>Units</b>		
<b>Plant Characteristics</b>		
Net Plant Capacity (60 deg F, 60% RH)	MW	418
Heat Rate, HHV Basis	Btu/kWh	6431
<b>Capital Cost Assumptions</b>		
EPC Contracting Fee	% of Direct & Indirect Costs	10%
Project Contingency	% of Project Costs	10%
Owner's Services	% of Project Costs	7%
Estimated Land Requirement (acres)	\$	60
Estimated Land Cost (\$/acre)	\$	30,000
<b>Interconnection Costs</b>		
Electrical Transmission Line Costs	\$/mile	1,800,000
Miles	miles	1.00
Substation Expansion	\$	0



<b>Case 8</b>			
<b>EIA – Capital Cost Estimates – 2019 \$\$</b>			
<b>Configuration</b>	<b>Combined Cycle 1x1x1, Single Shaft H Class</b>  Dry Low NOx combustor with axial fuel staging  SCR Catalyst, CO Catalyst  Natural Gas / No. 2 Backup  No Post Firing		
<b>Combustion Emissions Controls</b>			
<b>Post-Combustion Emissions Controls</b>			
<b>Fuel Type</b>			
<b>Post Firing</b>			
<b>Units</b>			
<i>Gas Interconnection Costs</i>			
Pipeline Cost	\$/mile		2,800,000
Miles	miles		0.50
Metering Station	\$		4,500,000
<i>Typical Project Timelines</i>			
Development, Permitting, Engineering	months		18
Plant Construction Time	months		22
Total Lead Time Before COD	months		40
Operating Life	years		25
<b>Cost Components (Note 1)</b>		<b>Breakout</b>	<b>Total</b>
<i>Civil/Structural/Architectural Subtotal</i>			31,000,000
Mechanical – Major Equipment	\$	130,000,000	
Mechanical – Balance of Plant	\$	73,000,000	
<i>Mechanical Subtotal</i>			203,000,000
<i>Electrical Subtotal</i>			28,000,000
Project Indirects	\$		80,000,000
EPC Total Before Fee	\$		342,000,000
EPC Fee	\$		34,200,000
<b>EPC Subtotal</b>			<b>376,200,000</b>
<b>Owner's Cost Components (Note 2)</b>			
Owner's Services	\$		26,334,000
Land	\$		1,800,000
Electrical Interconnection	\$		1,800,000
Gas Interconnection	\$		5,900,000
<b>Owner's Cost Subtotal</b>			<b>35,834,000</b>
<b>Project Contingency</b>			<b>41,203,000</b>
<b>Total Capital Cost</b>			<b>453,237,000</b>
<b>\$/kW net</b>			<b>1,084</b>
<b>Capital Cost Notes</b>			
<p>1. Costs based on EPC contracting approach. Direct costs include equipment, material, and labor to construct the civil/structural, mechanical, and electrical/I&amp;C components of the facility. Indirect costs include distributable material and labor costs, cranes, scaffolding, engineering, construction management, startup and commissioning, and contractor overhead. EPC fees are applied to the sum of direct and indirect costs.</p> <p>2. Owner's costs include project development, studies, permitting, legal, owner's project management, owner's engineering, and owner's startup and commissioning costs. Other owner's costs include electrical interconnection costs, gas interconnection costs (if applicable), and land acquisition costs.</p>			

### 8.3 O&M COST ESTIMATE

Operation and maintenance costs are indicated in Table 8-2. Fixed O&M costs include staff and administrative costs, supplies, and minor routine maintenance. (Not included are property taxes and insurance.) Fixed costs also include the fixed payment portion of a long-term service agreement for the CT.



Variable O&M costs include consumable commodities such as water, lubricants, and chemicals and periodic costs to change out the SCR and CO catalyts. The variable O&M costs also include the average annual cost of the planned maintenance events for the CT and the STG over the long-term maintenance cycle. Planned maintenance costs for the CT in a given year are based on the number of EOH the CT has run. A significant overhaul is typically performed for this type of CT every 25,000 EOH, and a major overhaul is performed every 50,000 EOH. (CTs generally have two criteria to schedule overhauls: number of equivalent starts and number of EOH. In Case 8, it is assumed the operating profile results in an EOH-driven maintenance overhaul schedule. Refer to Case 6 for a starts-based overhaul schedule.) Planned major outage work on the STG is scheduled less frequently than the CT; it is typically planned for every six to eight years.

**Table 8-2 — Case 8 O&M Cost Estimate**

<b>Case 8</b>			
<b>EIA – Non-Fuel O&amp;M Costs – 2019 \$s</b>			
Combined Cycle 1x1x1, Single Shaft			
<b>Fixed O&amp;M – Plant (Note 1)</b>			
Subtotal Fixed O&M	\$kW-/year	<b>14.10 \$/kW-year</b>	
<b>Variable O&amp;M (Note 2)</b>			
	\$/MWh	<b>2.55 \$/MWh</b>	
<b>O&amp;M Cost Notes</b>			
1. Fixed O&M costs include labor, materials and contracted services, and G&A costs. O&M costs exclude property taxes and insurance.			
2. Variable O&M costs include catalyst replacement, ammonia, water, and water discharge treatment cost.			

## 8.4 ENVIRONMENTAL & EMISSIONS INFORMATION

For the Case 8 CC configuration, NO<sub>x</sub> emissions from the HRSG stack when firing gas are indicated in Table 8-3. An SCR and a CO catalyst are included in the HRSG to reduce HRSG stack emissions of NO<sub>x</sub> and CO below the emission levels in the CT exhaust gas.

**Table 8-3 — Case 8 Emissions**

<b>Case 8</b>			
<b>EIA – Emissions Rates</b>			
Combined Cycle 1x1x1, Single Shaft			
<b>Predicted Emissions Rates (Note 1)</b>			
NO <sub>x</sub>	lb/MMBtu	0.0075 (Note 2)	
SO <sub>2</sub>	lb/MMBtu	0.00	
CO <sub>2</sub>	lb/MMBtu	117	
<b>Emissions Control Notes</b>			
1. Natural Gas, no water injection			



## **CASE 9. COMBUSTION TURBINE H CLASS, COMBINED-CYCLE SINGLE SHAFT WITH 90% CO<sub>2</sub> CAPTURE, 430 MW**

### **9.1 CASE DESCRIPTION**

This case includes one block of a combined-cycle power generation unit in a 1x1x1 single-shaft configuration. The plant includes one industrial frame Model H “advanced technology” CT, one STG, and one electric generator that is common to the CT and the STG. Case 9 is based on natural gas firing of the CT, although dual fuel capability is provided. Main plant cooling is accomplished with a wet cooling tower system. Output power voltage is stepped up for transmission to the external grid through an onsite switchyard.

In addition, a system is included to remove and capture 90% of the CO<sub>2</sub> in the CT exhaust gas.

Refer to Case 8 for a description the power generation systems, since Case 9 is the same in this regard.

#### **9.1.1 Mechanical Equipment & Systems**

This technology case adds a 90% CO<sub>2</sub> capture system to an industrial frame GE Model H 7HA.01 dual fuel CTs in a 1x1x1 single-shaft CC configuration. The nominal output of the CC plant unit without carbon capture is 430.4 MW gross. The major power cycle equipment and configurations are described in Case 8. The CO<sub>2</sub> capture systems are commonly referred to as CCS systems; however, for cost estimates provided in this report, no sequestration costs have been included. For this case, the CO<sub>2</sub> captured is assumed to be compressed to supercritical conditions and injected into a pipeline that terminates at the facility’s fence line. For this report, the terms “CO<sub>2</sub> capture” and “carbon capture” are used interchangeably. For a brief description of the post-combustion, amine-based CO<sub>2</sub> capture system, please refer to Case 5.

As with the technology of Case 8, the base configuration used for the cost estimate is a single CC unit power generation plant station constructed on a greenfield site of approximately 60 acres. A wet mechanical draft cooling tower is used for plant cycle cooling and the makeup water used for cycle cooling and steam cycle makeup is provided by an adjacent fresh water source, reservoir, or river.

For Case 9, to obtain 90% CO<sub>2</sub> removal from the flue gas generated from the CT, the full flue gas path must be treated. The flue gas generated from natural gas-fired CT combustions results in a much lower CO<sub>2</sub> concentration in the flue gas than flue gas from a coal-fired facility. As such, the flue gas absorber



and quencher would be much larger in scale on a per ton of CO<sub>2</sub> treated basis than with a coal facility. The stripper and compression system, however, would scale directly with the mass rate of CO<sub>2</sub> captured.

In this scenario, it is not practical to increase the CT size or STG size to account for the steam extraction and added auxiliary power required by the CO<sub>2</sub> capture system. The net power output in the CO<sub>2</sub> capture case is significantly less than Case 8.

The flue gas path differs from the base case (Case 8) in that 100% of the gas is directed to the carbon capture system located downstream of the preheater section of the HRSG. The SCR and CO catalysts would operate the same and the flue gas mass flows would be the same. Rather than exiting a stack, the flue gases would be ducted to a set of booster fans that would feed the CO<sub>2</sub> absorber column. The total gross power generated from the CT is approximately the same as Case 8 with no carbon capture.

Steam for the CO<sub>2</sub> stripper is to be extracted from the intermediate-pressure turbine to low-pressure turbine crossover line; however, the steam must be attemperated to meet the requirements of the carbon capture system. The total steam required for the carbon capture system is approximately 306,000 pounds per hour. As a result of the steam extraction, the gross STG generation outlet decreases from 133 MW to 112 MW.

The total auxiliary power required by the plant is 31.7 MW, of which 20 MW is used by the carbon capture system. The net output decreases from the base case (Case 8) from 418 MW to 377 MW. The net plant heat rate for the 90% carbon capture case is 7124 Btu/kWh, HHV basis (compared to 6431 Btu/kWh, HHV basis, for Case 8).

### **9.1.2 Electrical & Control Systems**

The electrical and controls systems for this case is essentially similar in scope to Case 8's electrical system; however, the auxiliary power system supplies a much larger amount of medium voltage load for the 90% carbon capture case.

The CC facility and the CO<sub>2</sub> capture plant are controlled by a central DCS, which is linked to a CT control system provided by the CT manufacturer. It includes controls for the steam cycle systems and equipment as well as the BOP systems and equipment (e.g., water systems, fuel systems, main cooling systems).



### 9.1.3 Offsite Requirements

Offsite provisions in Case 9 include:

- **Fuel Gas Supply:** A half-mile-long pipeline and a dedicated metering station.
- **High-Voltage Transmission Line:** A is a one-mile long transmission line.
- **Water Supply for Cooling Tower, Evaporative Coolers, Makeup to Steam Cycle, and Miscellaneous Uses:** It is assumed that the water supply source is near the power plant site and the interconnection for water is at the plant's site boundary. The volume of water needed for this 90% carbon capture case is significantly higher than for the base CC case (Case 8). The estimated increase in cooling water makeup is approximately 1,500 gallons per minute. Blowdown waste from the cooling tower and other areas of the plant is sent to an approved discharge location after appropriate treatment of the wastewater, and the wastewater interconnection is assumed to be located at the power plant's site boundary.

## 9.2 CAPITAL COST ESTIMATE

The base cost estimate for this technology case totals \$2481/kW. Table 9-1 summarizes the cost components for this case. The capital cost estimate is based on an EPC contracting approach.

In addition to EPC contract costs, the capital cost estimate in Table 9-1 covers owner's costs, which include project development, studies, permitting, and legal; owner's project management; owner's engineering; and owner's participation in startup and commissioning. The estimate is presented as an overnight cost in 2019 dollars and thus excludes Allowance for Funds Used During Construction or interest during construction. In addition to the cost of external systems noted above (e.g., fuel gas supply and transmission line), an estimated amount is included for the cost of land.



Table 9-1 — Case 9 Capital Cost Estimate

Case 9 EIA – Capital Cost Estimates – 2019 \$\$		
<b>Configuration</b>	<b>Combined Cycle 1x1x1, Single Shaft, w/ 90% Carbon Capture</b>	
<b>Combustion Emissions Controls</b>	H-Class Dry Low NOx combustor with axial fuel staging	
<b>Post-Combustion Emissions Controls</b>	SCR Catalyst, CO Catalyst	
<b>Fuel Type</b>	Natural gas / No. 2 Backup	
<b>Post Firing</b>	No Post Firing	
<b>Units</b>		
<b>Plant Characteristics</b>		
Net Plant Capacity (60 deg F, 60% RH)	MW	377
Heat Rate, HHV Basis	Btu/kWh	7124
<b>Capital Cost Assumptions</b>		
EPC Contracting Fee	% of Direct & Indirect Costs	10%
Project Contingency	% of Project Costs	10%
Owner's Services	% of Project Costs	7%
Estimated Land Requirement (acres)	\$	60
Estimated Land Cost (\$/acre)	\$	30,000
<b>Interconnection Costs</b>		
<i>Electrical Transmission Line Costs</i>		
Miles	\$/mile	1,800,000
Substation Expansion	miles	1.00
Substation Expansion	\$	0
<i>Gas Interconnection Costs</i>		
Pipeline Cost	\$/mile	2,800,000
Miles	miles	0.50
Metering Station	\$	4,500,000
<b>Typical Project Timelines</b>		
Development, Permitting, Engineering	months	24
Plant Construction Time	months	30
Total Lead Time Before COD	months	54
Operating Life	years	40
<b>Cost Components (Note 1)</b>		<b>Breakout</b>
<i>Civil/Structural/Architectural Subtotal</i>	\$	<b>Total</b>
Mechanical – Major Equipment	\$	130,000,000
Mechanical – Balance of Plant	\$	73,000,000
<i>Mechanical Subtotal</i>	\$	203,000,000
<i>Electrical Subtotal</i>	\$	28,000,000
<i>CCS Plant Subtotal</i>	\$	362,306,000
Project Indirects	\$	90,000,000
EPC Total Before Fee	\$	714,306,000
EPC Fee	\$	71,430,600
<b>EPC Subtotal</b>	\$	<b>785,736,600</b>
<b>Owner's Cost Components (Note 2)</b>		
Owner's Services	\$	55,002,000
Land	\$	1,800,000
Electrical Interconnection	\$	1,800,000
Gas Interconnection	\$	5,900,000
<b>Owner's Cost Subtotal</b>	\$	<b>64,502,000</b>
<b>Project Contingency</b>	\$	<b>85,024,000</b>
<b>Total Capital Cost</b>	\$	<b>935,262,600</b>
	<b>\$/kW net</b>	<b>2,481</b>





<b>Case 9 EIA – Capital Cost Estimates – 2019 \$\$</b>	
<b>Configuration</b>	<b>Combined Cycle 1x1x1, Single Shaft, w/ 90% Carbon Capture</b>
<b>Combustion Emissions Controls</b>	H-Class Dry Low NOx combustor with axial fuel staging
<b>Post-Combustion Emissions Controls</b>	SCR Catalyst, CO Catalyst
<b>Fuel Type</b>	Natural gas / No. 2 Backup
<b>Post Firing</b>	No Post Firing
<b>Capital Cost Notes</b>	
<p>1. Costs based on EPC contracting approach. Direct costs include equipment, material, and labor to construct the civil/structural, mechanical, and electrical/I&amp;C components of the facility. Indirect costs include distributable material and labor costs, cranes, scaffolding, engineering, construction management, startup and commissioning, and contractor overhead. EPC fees are applied to the sum of direct and indirect costs.</p> <p>2. Owner's costs include project development, studies, permitting, legal, owner's project management, owner's engineering, and owner's startup and commissioning costs. Other owner's costs include electrical interconnection costs, gas interconnection costs (if applicable), and land acquisition costs.</p>	

### 9.3 O&M COST ESTIMATE

Operation and maintenance costs are indicated in Table 9-2. Fixed O&M costs include staff and administrative costs, supplies, and minor routine maintenance. (Not included are property taxes and insurance.) Fixed costs also include the fixed payment portion of a long-term service agreement for the CT and carbon capture system equipment.

Variable O&M costs include consumable commodities such as water, lubricants, chemicals, solvent makeup, and periodic costs to change out the SCR and CO catalysts. The variable O&M costs also include the average annual cost of the planned maintenance events for the CT and the STG over the long-term maintenance cycle. Planned maintenance costs for the CT in a given year are based on the number of EOH the CT has run. A significant overhaul is typically performed for this type of CT every 25,000 EOH, and a major overhaul is performed every 50,000 EOH. (CTs generally have two criteria to schedule overhauls: number of equivalent starts and number of EOH. In Case 9, it is assumed the operating profile results in an EOH-driven maintenance overhaul schedule. Refer to Case 6 for a start-based overhaul schedule.) Planned major outage work on the STG is scheduled less frequently than the CT; it is typically planned for every six to eight years.

For the CO<sub>2</sub> capture system, variable costs include solvent makeup and disposal costs (usually offsite disposal; the spent solvent may be considered hazardous waste), additional wastewater treatment costs (predominantly CT blowdown treatment), and additional demineralized makeup water costs.



Table 9-2 — Case 9 O&amp;M Cost Estimate

Case 9 EIA – O&M Costs – 2019 \$s		
Combined Cycle 1x1x1, Single Shaft, w/ 90% Carbon Capture		
<b>Fixed O&amp;M – Plant (Note 1)</b>		
Subtotal Fixed O&M	\$/kW-year	27.60 \$/kW-year
<b>Variable O&amp;M (Note 2)</b>	\$/MWh	5.84 \$/MWh
<b>O&amp;M Cost Notes</b>		
1. Fixed O&M costs include labor, materials and contracted services, and G&A costs. O&M costs exclude property taxes and insurance.		
2. Variable O&M costs include catalyst replacement, ammonia, water, and water discharge treatment cost.		

## 9.4 ENVIRONMENTAL & EMISSIONS INFORMATION

For the Case 9 CC configuration with 90% carbon capture, NO<sub>x</sub> emissions from the plant when firing gas are indicated in Table 9-3. An SCR and a CO catalyst are included in the HRSG to further reduce plant emissions of NO<sub>x</sub> and CO below the emissions levels in the CT exhaust gas. The CO<sub>2</sub> in the CT exhaust gas is reduced by 90% for Case 9.

Table 9-3 — Case 9 Emissions

Case 9 EIA – Emissions Rates		
Combined Cycle 1x1x1, Single Shaft, w/ 90% Carbon Capture		
<b>Predicted Emissions Rates (Note 1)</b>		
NO <sub>x</sub>	lb/MMBtu	0.0075 (Note 2)
SO <sub>2</sub>	lb/MMBtu	0.00
CO <sub>2</sub>	lb/MMBtu	12
<b>Emissions Control Notes</b>		
1. Natural Gas, no water injection		



---

## CASE 10. FUEL CELL, 10 MW

### 10.1 CASE DESCRIPTION

This case is based on a 10-MW fuel cell power generation facility using a series of identical modular fuel cells. Fuel cells use a potential difference between a cathode and an anode. There is a chemical reaction between oxygen from the air and the fuel within the anode that releases an electron to generate a current. There are many types of fuel cells, but only two technologies have demonstrated capability for utility-sized projects: molten carbonate fuel cell and solid oxide fuel cells. These types of fuel cells operate at high temperatures, (greater than 1,000°F) providing the unique ability to use multiple types of fuel and allows for more design options such as combined heat and power production. This study is based on solid oxide fuel cells oriented in multiple 300-kW stacks. Solid oxide fuel cell stacks are intended to act as modular components that can be combined in various geometries to generate whatever capacity is required for the project. The 10-MW solid oxide fuel cell plant used in this estimate comprises 36 fuel cell stacks operating at 92% capacity. These stacks would be grouped together in 3 groups of 12 stacks, and each group would have its own inverter.

#### 10.1.1 Chemical Operation

A solid oxide fuel cell stack is comprised of thousands of individual fuel cells made of a ceramic electrolyte (typically yttria stabilized zirconia) with a thin anode coating on one side and cathode coating on the other. Solid oxide fuel cells operate by generating steam to reform natural gas methane into hydrogen and carbon monoxide at the anode. At the same time, hot air passes over the cathode which absorbs oxygen molecules. The oxygen molecules react with the electrons in the cathode to form oxygen ions that pass through an electrolyte to combine with the hydrogen and carbon monoxide in the anode to form carbon dioxide, water, a free electron, and heat. The free electron is harnessed and used to generate an electrical current that can be converted into power, the water and heat are recycled to continually generate steam to reform the fuel, and the carbon dioxide is a waste byproduct that is released outside of the fuel cell.

Table 10-1 — Fuel Cell Chemical Reactions

Reaction	Equation
Steam Reforming	$CH_4 + H_2O (g) \xrightarrow{\text{yields}} 3H_2 + CO$
Electrolyte Reaction	$3H_2 + CO + 2O_2 \xrightarrow{\text{yields}} CO_2 + 2H_2O + e^- + \text{Heat}$
Net Solid Oxide Fuel Cell	$CH_4 + H_2O (g) + 2O_2 \xrightarrow{\text{yields}} CO_2 + H_2O + e^- + \text{Heat}$

Figure 10-1 — Simplified Solid Oxide Fuel Cell

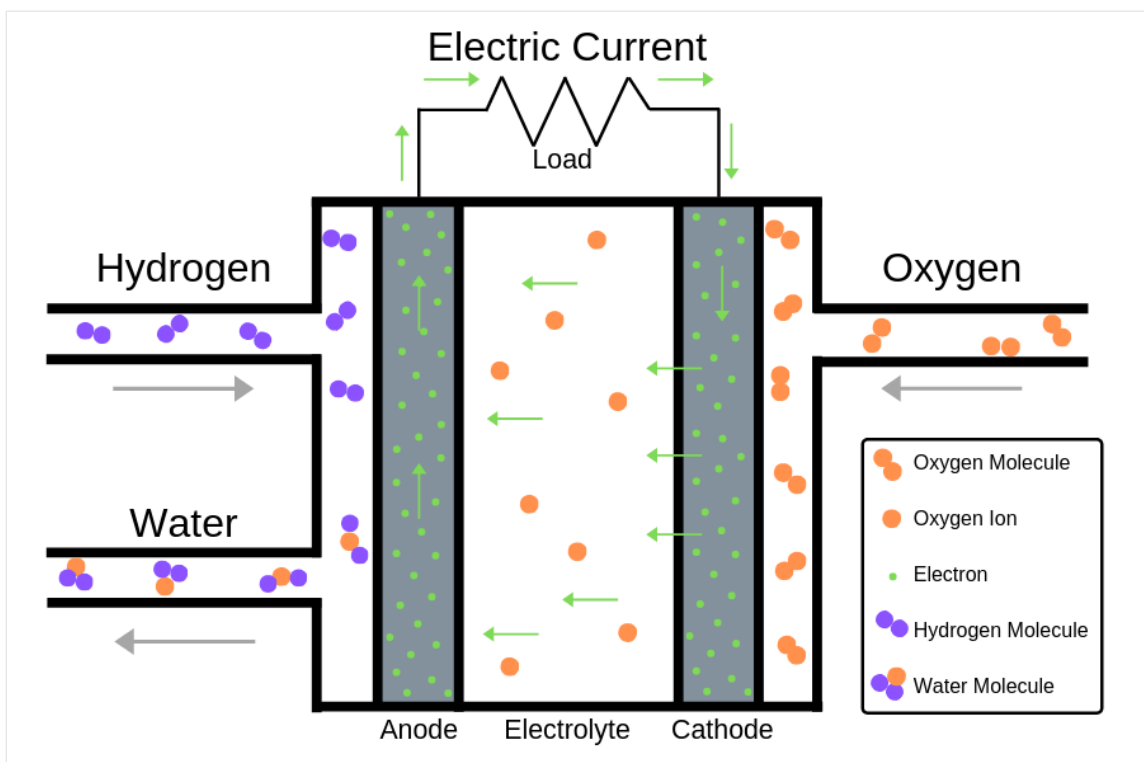

Adapted from Battery Japan,  
<https://www.batteryjapan.jp/en-gb/visit/feature10-tokyo.html> (accessed June 12, 2019)

### 10.1.2 Mechanical Equipment & Systems

Due to the small physical size and relative simplicity in design of these modular fuel cell stacks, minimal additional equipment is required. The heating of air and water, fuel reforming, and current generation all occur within the fuel stack itself. Their only external mechanical requirement is a foundation and the gas interconnection for the fuel. For this cost breakdown, however, the stack itself will refer only to the fuel cells within it. The mechanical BOP includes heat recovery components; the fuel processor components; and the supply components for the fuel, water, and air. The electrical equipment includes the power electric equipment such as the inverter and step-up transformer as well as the control and

instrumentation equipment. The most expensive single component of the facility is the electric inverters. Fuel cells use a hybrid inverter. Hybrid inverters eliminate the need for a direct current (DC)/DC converter to match the battery voltage and are relatively new on the market. The recent development of these inverters makes them more expensive than other inverters.

**Figure 10-2 — Typical Solid Oxide Fuel Cell Project**



**Source:** Office of Fossil Energy – U.S. Department of Energy, ND. Digital Image.  
Retrieved from Energy.gov, <https://www.energy.gov/fe/science-innovation/clean-coal-research/solid-oxide-fuel-cells>  
(accessed July 8, 2019).

### 10.1.3 Offsite Requirements

Fuel cells require a water supply and natural fuel supply as well as water discharge. They are typically designed near existing transmission lines and typically have minimal offsite electrical interconnection and transmission costs.

## 10.2 CAPITAL COST ESTIMATE

The base cost estimate for this technology case totals \$6700/kW. Table 10-2 summarizes the cost components for this case. Although the costs shown are based on an EPC contracting basis, the utility-sized fuel cell projects have been structured as build, own, operate, and maintain by the fuel cell manufacturers with electricity purchase agreements with the client or end user at a set \$/kilowatt hour (kWh) basis. With that in mind, most of the solid oxide fuel cell applications are for individual entities,



not microgrid or utility operations. These individual entities can range from small-scale businesses to large data centers that need 10+ MW of constant, uninterruptible power because they are unable to be offline for more than a few minutes.

**Table 10-2 — Case 10 Capital Cost Estimate**

<b>Case 10</b>			
<b>EIA – Capital Cost Estimates – 2019 \$s</b>			
<b>Configuration</b>		<b>Fuel Cell</b>	
<b>Fuel Cell Type</b>		34 x 300 kW Gross	
<b>Fuel Type</b>		Solid Oxide	
		Natural Gas	
<b>Units</b>			
<b>Plant Characteristics</b>			
Net Plant Capacity	MW		10
Heat Rate	Btu/kWh		6469
<b>Capital Cost Assumptions</b>			
EPC Contracting Fee	% of Direct & Indirect Costs		5%
Project Contingency	% of Project Costs		4%
Owner's Services	% of Project Costs		8%
Estimated Land Requirement (acres)	\$		2
Estimated Land Cost (\$/acre)	\$		30,000
<b>Interconnection Costs</b>			
<b>Gas Interconnection Costs</b>			
Pipeline Cost	\$/mile		2,500,000
Miles	miles		0.25
Metering Station	\$		1,200,000
<b>Typical Project Timelines</b>			
Development, Permitting, Engineering	months		21
Plant Construction Time	months		3
Total Lead Time Before COD	months		24
Operating Life	years		20
<b>Cost Components (Note 1)</b>		<b>Breakout</b>	<b>Total</b>
<i>Civil/Structural/Architectural Subtotal</i>	\$		3,764,000
Mechanical – Fuel Cell Stacks	\$	11,601,000	
Mechanical – Balance of Plant	\$	16,033,000	
<i>Mechanical Subtotal</i>	\$		27,634,000
<i>Electrical Subtotal</i>	\$		21,809,000
Project Indirects	\$		3,075,000
EPC Total Before Fee	\$		56,282,000
EPC Fee	\$		2,814,000
<b>EPC Subtotal</b>	\$		<b>59,096,000</b>
<b>Owner's Cost Components (Note 2)</b>			
Owner's Services	\$		4,728,000
Land	\$		60,000
Gas Interconnection	\$		1,825,000
<b>Owner's Cost Subtotal</b>	\$		<b>6,613,000</b>
<b>Project Contingency</b>	\$		<b>2,628,000</b>
<b>Total Capital Cost</b>	\$		<b>68,337,000</b>
	<b>\$/kW net</b>		<b>6,700</b>



<b>Case 10 EIA – Capital Cost Estimates – 2019 \$s</b>	
<b>Configuration</b>	<b>Fuel Cell</b> 34 x 300 kW Gross
<b>Fuel Cell Type</b>	Solid Oxide
<b>Fuel Type</b>	Natural Gas
<b>Capital Cost Notes</b>	
<p>1. Costs based on EPC contracting approach. Direct costs include equipment, material, and labor to construct the civil/structural, mechanical, and electrical/I&amp;C components of the facility. Indirect costs include distributable material and labor costs, cranes, scaffolding, engineering, construction management, startup and commissioning, and contractor overhead. EPC fees are applied to the sum of direct and indirect costs.</p> <p>2. Owner's costs include project development, studies, permitting, legal, owner's project management, owner's engineering, and owner's startup and commissioning costs. Other owner's costs include electrical interconnection costs, gas interconnection costs (if applicable), and land acquisition costs.</p>	

### 10.3 O&M COST ESTIMATE

Common practice for solid oxide fuel cell vendors is to build, operate, and maintain the fuel cell plant while charging a fixed monthly O&M to the owner of the project (i.e., the utility or corporation to which they are selling the energy). This leads to a large amount of fixed O&M costs. The only exception being the water supply and discharge, which is left to the owner. These costs are shown as variable O&M within this estimate.

**Table 10-3 — Case 10 O&M Cost Estimate**

<b>Case 10 EIA – Non-Fuel O&amp;M Costs – 2019 \$s</b>			
Fuel Cell			
<b>Fixed O&amp;M – Plant (Note 1)</b>			
Routine Maintenance & Management	\$/year	34,000	
Fuel Cell Maintenance Reserve	\$/year	280,000	
Subtotal Fixed O&M	\$/year	314,000	
\$/kW-year	\$/kW-year	<b>30.78 \$/kW-year</b>	
<b>Variable O&amp;M (Note 2)</b>	\$/MWh	<b>0.59 \$/MWh</b>	
<b>O&amp;M Cost Notes</b>			
<p>1. Fixed O&amp;M costs include labor, materials and contracted services, and G&amp;A costs. O&amp;M costs exclude property taxes and insurance.</p> <p>2. Variable O&amp;M includes costs of water supply and water discharge.</p>			

### 10.4 ENVIRONMENTAL & EMISSIONS INFORMATION

Solid oxide fuel cell emissions are dependent on the fuel that is used: biofuel or natural gas. Biofuel allows for a reduction in emissions but carries a higher associated heat rate and operating cost. Therefore, in the interest of being economically competitive, most fuel cells today use natural gas. Even when using natural gas as the fuel source, fuel cells are considered a clean energy source. One important distinction between a natural gas-powered combustion turbine and a fuel cell that uses natural gas is



that the fuel cell does not burn the gas. Within the fuel cell, natural gas is reformed with steam, which still releases CO<sub>2</sub> but reduces the other emissions, allowing fuel cells to maintain their “green” status.

**Table 10-4 — Case 10 Emissions**

<b>Case 10</b>			
<b>EIA – Emissions Rates</b>			
Fuel Cell			
<b>Predicted Emissions Rates (Note 1)</b>			
	NO <sub>x</sub>	lb/MMBtu	0.0002
	SO <sub>2</sub>	lb/MMBtu	0.00
	CO	lb/MMBtu	0.005
	CO <sub>2</sub>	lb/MMBtu	117
<b>Emissions Control Notes</b>			
1. Natural Gas			





## CASE 11. ADVANCED NUCLEAR, 2156 MW

### 11.1 CASE DESCRIPTION

The case is based on the AP1000 (“AP” stands for “Advanced Passive”), which is an improvement of AP600. The AP1000 is a pressurized water reactor nuclear plant designed by Westinghouse. The first AP1000 unit came online in June 2018.

#### 11.1.1 Mechanical Equipment & Systems

The AP1000 improves on previous nuclear designs by simplifying the design to decrease the number of components including piping, wiring, and valves. The AP1000 design is also standardized as much as possible to reduce engineering and procurement costs. The AP1000 component reductions from previous designs are approximately:

- 50% fewer valves
- 35% fewer pumps
- 80% less pipe
- 45% less seismic building volume
- 85% less cable

The AP1000 design uses an improved passive nuclear safety system that requires no operator intervention or external power to remove heat for up to 72 hours.

The AP1000 uses a traditional steam cycle similar to other generating facilities such as coal or CC units. The primary difference is that the AP1000 uses enriched uranium as fuel instead of coal or gas as the heat source to generate steam. The enriched uranium is contained inside the pressurized water reactor. The AP1000 uses a two-loop system in which the heat generated by the fuel is released into the surrounding pressurized reactor cooling water. The pressurization allows the cooling water to absorb the released heat without boiling. The cooling water then flows through a steam generator that provide steam to the steam turbine for electrical generation.

#### 11.1.2 Electrical & Control Systems

The advanced nuclear facility has one steam turbine electric generator for each reactor. Each generator is a 60-Hz machine rated at approximately 1,250 MVA with an output voltage of 24 kV. The steam turbine electric generator is connected through a generator circuit breaker to a GSU. The GSI is



connected between two circuit breakers in the high-voltage bus in the facility switchyard through a disconnect switch. The GSU increases the voltage from the electric generator from 24 kV to interconnected transmission system high voltage.

The advanced nuclear facility is controlled using a DCS. The DCS provides centralized control of the facility by integrating the control systems provided with the reactor, steam turbine, and associated electric generator and the control of BOP systems and equipment.

### 11.1.3 Offsite Requirements

Water for all processes at the power plant is obtained from a nearby river or lake. The power plant uses a water treatment system to produce the high-quality process water required as well as service and potable water. The electrical interconnection from the power plant onsite switchyard is typically connected to the transmission line through a nearby substation.

## 11.2 CAPITAL COST ESTIMATE

The base cost estimate for this technology case totals \$6041/kW. Table 11-1 summarizes the cost components for this case.

**Table 11-1 — Case 11 Capital Cost Estimate**

Case 11 EIA – Capital Cost Estimates – 2019 \$s		
Configuration		Advanced Nuclear (Brownfield) 2 x AP1000
Units		
<b>Plant Characteristics</b>		
Net Plant Capacity (60 deg F, 60% RH)	MW	2156
Net Plant Heat Rate, HHV Basis	Btu/kWh	10608
<b>Capital Cost Assumptions</b>		
EPC Contracting Fee	% of Direct & Indirect Costs	10%
Project Contingency	% of Project Costs	10%
Owner's Services	% of Project Costs	20.0%
Estimated Land Requirement (acres)	\$	60
Estimated Land Cost (\$/acre)	\$	30,000
<b>Interconnection Costs</b>		
<i>Electrical Transmission Line Costs</i>		
	\$/mile	2,520,000
Miles	miles	1.00
Substation Expansion	\$	0
<i>Gas Interconnection Costs</i>		
Pipeline Cost	\$/mile	0
Miles	miles	0.00
Metering Station	\$	0



Case 11 EIA – Capital Cost Estimates – 2019 \$s			
Configuration	Advanced Nuclear (Brownfield) 2 x AP1000		
Units			
<i>Typical Project Timelines</i>			
Development, Permitting, Engineering	months		24
Plant Construction Time	months		48
Total Lead Time Before COD	months		72
Operating Life	years		40
<b>Cost Components (Note 1)</b>		<b>Breakout</b>	<b>Total</b>
<i>Civil/Structural/Architectural Subtotal</i>	\$		1,675,180,000
Nuclear Island	\$	2,463,500,000	
Conventional Island	\$	1,379,560,000	
Balance of Plant	\$	788,320,000	
<i>Mechanical Subtotal</i>	\$		4,631,380,000
<i>Electrical Subtotal</i>	\$		788,320,000
Project Indirects	\$		1,872,260,000
EPC Total Before Fee	\$		8,967,140,000
EPC Fee	\$		896,714,000
<b>EPC Subtotal</b>	\$		<b>9,863,854,000</b>
<b>Owner's Cost Components (Note 2)</b>			
Owner's Services	\$		1,972,771,000
Land	\$		1,800,000
Electrical Interconnection	\$		2,520,000
Gas Interconnection	\$		0
<b>Owner's Cost Subtotal</b>	\$		<b>1,977,091,000</b>
<b>Project Contingency</b>	\$		<b>1,184,095,000</b>
<b>Total Capital Cost</b>	\$		<b>13,025,040,000</b>
		<b>\$/kW net</b>	<b>6,041</b>
<b>Capital Cost Notes</b>			
1. Costs based on EPC contracting approach. Direct costs include equipment, material, and labor to construct the civil/structural, mechanical, and electrical/I&C components of the facility. Indirect costs include distributable material and labor costs, cranes, scaffolding, engineering, construction management, startup and commissioning, and contractor overhead. EPC fees are applied to the sum of direct and indirect costs.			
2. Owner's costs include project development, studies, permitting, legal, owner's project management, owner's engineering, and owner's startup and commissioning costs. Other owner's costs include electrical interconnection costs, gas interconnection costs (if applicable), and land acquisition costs.			

Owner's costs were reviewed to ensure that utility interconnection costs were accounted for appropriately. Specifically, the transmission line for the nuclear facility is expected to operate at a high voltage to be capable of exporting the large capacity of baseload power.

### 11.3 O&M COST ESTIMATE

The O&M cost estimate includes all tasks discussed in the O&M estimate description.



Table 11-2 — Case 11 O&amp;M Cost Estimate

Case 11 EIA – Non-Fuel O&M Costs – 2019 \$\$		
Advanced Nuclear (Brownfield)		
<b>Fixed O&amp;M – Plant (\$/year) (Note 1)</b>		
Subtotal Fixed O&M	\$/kW-year	121.64 \$/kW-year
<b>Variable O&amp;M (\$/MWh) (Note 2)</b>	\$/MWh	2.37 \$/MWh
<b>O&amp;M Cost Notes</b>		
1. Fixed O&M costs include labor, materials and contracted services, and G&A costs. O&M costs exclude property taxes and insurance.		
2. Variable O&M costs include water, water discharge treatment cost, chemicals, and consumables. Fuel is not included.		

#### 11.4 ENVIRONMENTAL & EMISSIONS INFORMATION

Nuclear power plants do not produce regulated environmental air emissions. While other environmental compliance requirements may apply, only air emissions were considered for this report. Therefore, the emissions of NO<sub>x</sub>, SO<sub>2</sub>, and CO<sub>2</sub> are 0.00 lb/MMBtu.



## **CASE 12. SMALL MODULAR REACTOR NUCLEAR POWER PLANT, 600 MW**

### **12.1 CASE DESCRIPTION**

This case is based on 12 small reactor modules. Each module has a net capacity of 50 MW for a net plant capacity of 600 MW. The small modular reactor (SMR) case is not based on a particular OEM but rather is a representative SMR plant.

#### **12.1.1 Mechanical Equipment and Systems**

The mechanical systems of an SMR are much smaller than those of a traditional nuclear plant. The mechanical systems are similar to that of an advanced nuclear power plant. Each reactor module is comprised of a nuclear core and steam generator within a reactor vessel, which is enclosed within a containment vessel in a vertical orientation. The nuclear core is located at the base of the module with the steam generator located in the upper half of the module. Feedwater enters and steam exits through the top of the vessel towards the steam turbine. The entire containment vessel sits within a water-filled pool that provides cooling and passive protection in a loss of power event. All 12 reactor modules sit within the same water-filled pool housed within a common reactor building.

Each SMR module uses a pressurized water reactor design to achieve a high level of safety and reduce the number of components required. To improve on licensing and construction times, each reactor is prefabricated at the OEM's facility and shipped to site for assembly. The compact integral design allows each reactor to be shipped by rail, truck, or barge.

Each module has a dedicated BOP system for power generation. Steam from the reactor module is pumped through a steam turbine connected to a generator for electrical generation. Each BOP system is fully independent, containing a steam turbine and all necessary pumps, tanks, heat exchangers, electrical equipment, and controls for operation. This allows for independent operation of each reactor module. The independent operation of each reactor module allows for greater efficiencies at lower operating loads when dispatched capacity is reduced.

Additionally, the modular design of the reactors allows for refueling and maintenance of the individual reactors without requiring an outage of the entire facility. An extra reactor bay is including the pool housed with the reactor building. This extra bay allows for removal of individual reactors for maintenance without impacting the remaining reactors.



### 12.1.2 Electrical and Control Systems

Each SMR has its own generator, which is a 60-Hz machine rated at approximately 45 MVA with an output voltage of 13.8 kV. The steam turbine electric generator is connected through a generator circuit breaker to a GSU that is in turn connected between two circuit breakers in the high-voltage bus in the facility switchyard through a disconnect switch. The GSU increases the voltage from the electric generator from 13.8 kV to interconnected transmission system high voltage.

The SMR facility is controlled using a DCS. The DCS provides centralized control of the facility by integrating the control systems provided with the reactor, steam turbine, and associated electric generator and the control of BOP systems and equipment.

### 12.1.3 Offsite Requirements

Water for all processes at the SMR nuclear power plant is obtained from a nearby river or lake. The SMR power plant uses a water treatment system to produce the high-quality process water required as well as service and potable water. The electrical interconnection from the SMR nuclear power plant onsite switchyard is typically connected to the transmission line through a nearby substation.

## 12.2 CAPITAL COST ESTIMATE

The base cost estimate for this technology case totals \$6191/kW. Table 12-1 summarizes the cost components for this case.

**Table 12-1 — Case 12 Capital Cost Estimate**

<b>Case 12 EIA – Capital Cost Estimates – 2019 \$s</b>		
Configuration	Small Modular Reactor Nuclear Power Plant 12 x 50-MW Small Modular Reactor	
Units		
<b>Plant Characteristics</b>		
Net Plant Capacity	MW	600
Net Plant Heat Rate, HHV Basis	Btu/kWh	10046
<b>Capital Cost Assumptions</b>		
EPC Contracting Fee	% of Direct & Indirect Costs	10%
Project Contingency	% of Project Costs	10%
Owner's Services	% of Project Costs	7.5%
Estimated Land Requirement (acres)	acres	35
Estimated Land Cost (\$/acre)	\$	30,000
<b>Interconnection Costs</b>		
Electrical Transmission Line Costs	\$/mile	2,520,000
Miles	miles	1.00
Substation Expansion	\$	0



<b>Case 12</b>			
<b>EIA – Capital Cost Estimates – 2019 \$\$</b>			
<b>Configuration</b>	<b>Small Modular Reactor Nuclear Power Plant</b> 12 x 50-MW Small Modular Reactor		
<b>Units</b>			
<i>Gas Interconnection Costs</i>			
Pipeline Cost	\$/mile		0
Miles	miles		0.00
Metering Station	\$		0
<i>Typical Project Timelines</i>			
Development, Permitting, Engineering	months		24
Plant Construction Time	months		48
Total Lead Time Before COD	months		72
Operating Life	years		40
<b>Cost Components (Note 1)</b>		<b>Breakout</b>	<b>Total</b>
<i>Civil/Structural/Architectural Subtotal</i>			583,524,000
Nuclear Island	\$	648,360,000	
Conventional Island	\$	421,434,000	
Balance of Plant	\$	389,016,000	
<i>Mechanical Subtotal</i>	\$		1,458,810,000
<i>Electrical Subtotal</i>	\$		259,344,000
Project Indirects	\$		551,000,000
EPC Total Before Fee	\$		2,852,678,000
EPC Fee	\$		285,267,800
<b>EPC Subtotal</b>	<b>\$</b>		<b>3,137,945,800</b>
<b>Owner's Cost Components (Note 2)</b>			
Owner's Services	\$		235,346,000
Land	\$		1,050,000
Electrical Interconnection	\$		2,520,000
Gas Interconnection	\$		0
<b>Owner's Cost Subtotal</b>	<b>\$</b>		<b>238,916,000</b>
<b>Project Contingency</b>	<b>\$</b>		<b>337,686,000</b>
<b>Total Capital Cost</b>	<b>\$</b>		<b>3,714,547,800</b>
<b>\$/kW net</b>			<b>6,191</b>
<b>Capital Cost Notes</b>			
1. Costs based on EPC contracting approach. Direct costs include equipment, material, and labor to construct the civil/structural, mechanical, and electrical/I&C components of the facility. Indirect costs include distributable material and labor costs, cranes, scaffolding, engineering, construction management, startup and commissioning, and contractor overhead. EPC fees are applied to the sum of direct and indirect costs.			
2. Owner's costs include project development, studies, permitting, legal, owner's project management, owner's engineering, and owner's startup and commissioning costs. Other owner's costs include electrical interconnection costs, gas interconnection costs (if applicable), and land acquisition costs.			

Owner's costs include utility interconnection costs. Specifically, the transmission line for the SMR nuclear power plant is expected to operate at a high voltage to be capable of exporting the full plant output. The SMR costs also take into account that any SMR built at this time would be a first-of-a-kind facility. The indicated costs do not include financial incentives such as tax credits or cost sharing arrangements through public-private partnerships that may support first-of-a-kind facilities.



### 12.3 O&M COST ESTIMATE

The O&M cost estimate includes all tasks discussed in the O&M estimate description.

**Table 12-2 — Case 12 O&M Cost Estimate**

<b>Case 12</b>		
<b>EIA – Non-Fuel O&amp;M Costs – 2019 \$s</b>		
Small Modular Reactor Nuclear Power Plant		
<b>Fixed O&amp;M – Plant (Note 1)</b>		
Subtotal Fixed O&M	\$/kW-year	<b>95.00 \$/kW-year</b>
<b>Variable O&amp;M (Note 2)</b>	\$/MWh	<b>3.00 \$/MWh</b>
<b>O&amp;M Cost Notes</b>		
1. Fixed O&M costs include labor, materials and contracted services, and G&A costs. O&M costs exclude property taxes and insurance.		
2. Variable O&M costs include water, water discharge treatment cost, chemicals, and consumables. Fuel is not included.		

### 12.4 ENVIRONMENTAL & EMISSIONS INFORMATION

Small modular reactor nuclear power plants do not produce regulated environmental air emissions. While other environmental compliance requirements may apply, only air emissions were considered for this report. Therefore, the emissions of NO<sub>x</sub>, SO<sub>2</sub>, and CO<sub>2</sub> are 0.00 lb/MMBtu.





## CASE 13. BIOMASS PLANT, 50 MW

### 13.1 CASE DESCRIPTION

This case comprises a greenfield biomass-fired power generation facility with a nominal net capacity of 50 MW with a single steam generator and condensing steam turbine with biomass storage and handling systems, BOP systems, in-furnace, and post-combustion emissions control systems. The facility is designed to receive, store, and burn wood chips with moisture content between 20% and 50%. The technology used is a bubbling fluidized bed (BFB) boiler with bed material consisting of sand, crushed limestone, or ash. The facility does not include equipment to further process or dry the fuel prior to combustion. The fuel storage area is assumed to be uncovered. The facility does not have a connection to a natural gas supply and is designed to start up on diesel fuel only. The emission controls are used to limit NO<sub>x</sub> and particulate matter, while SO<sub>2</sub> and CO<sub>2</sub> are not controlled.

#### 13.1.1 Mechanical Equipment & Systems

The core technology for this case is a BFB boiler designed to fire wood chips. The boiler is a natural circulation balanced-draft, non-reheat cycle. For this size range, the boiler is assumed to be a top-supported design arranged in a similar manner as shown in Figure 13-1. The BFB furnace consists of horizontally arranged air distribution nozzles in the lower portion of the furnace that introduces air or recirculated flue gas to a bed of sand, ash, or other non-combustible material such as crushed limestone. The balanced-draft boiler consists of water-wall tubes that are refractory lined in the bed area. Air flow is forced upward through the bed material at velocities just beyond the point of fluidization where voids or bubbles start to form within the bed. The bed material is maintained typically at a range of temperatures between 1,400°F to 1,600°F, depending on the moisture content of the fuel. Diesel oil-fired startup burners are used to heat the bed material prior to the introduction of fuel. The biomass fuel is fed through chutes located in the lower furnace. Depending on the moisture content of the fuel, flue gases can be mixed with the fluidized air to control the bed heat release rate to levels that prevent the formation of agglomerated ash. Overfire air is used to complete combustion of the fuel and to control the emissions of NO<sub>x</sub>.

The steam cycle includes a condensing steam turbine and turbine auxiliaries, condensate pumps, low-pressure and high-pressure feedwater heaters, boiler feed pumps, economizers, furnace water walls, steam drum, and primary and secondary superheaters. Boiler feed pumps and condensate pumps are



provided in a 2x100% sizing basis. The steam conditions at the turbine are assumed to be 1500 psig at 950°F. Cycle cooling is provided by a mechanical draft cooling tower.

The air and flue gas systems include primary and secondary air fans, flue gas recirculation fans, a single tubular air heater, induced draft fans and the associated duct work, and dampers. The fans are assumed to be provided on a 2x50% basis. A material handling is provided to convey the wood chips to the fuel surge bins that direct the fuel to multiple feeders. The BOP equipment includes sootblowers, water treatment system and demineralized water storage tanks, a fire protection and detection system, diesel oil storage and transfer system, compressed air system, aqueous ammonia storage system and feed pumps, an ash handling and storage system, and a continuous emissions monitoring system.

NO<sub>x</sub> emissions are controlled in-furnace using OFA and with a high dust SCR system, SO<sub>2</sub> emissions from wood firing are inherently low and therefore are uncontrolled. Particulate matter is controlled using a pulse jet fabric filter baghouse.

Figure 13-1 — Typical BFB Biomass Boiler Arrangement

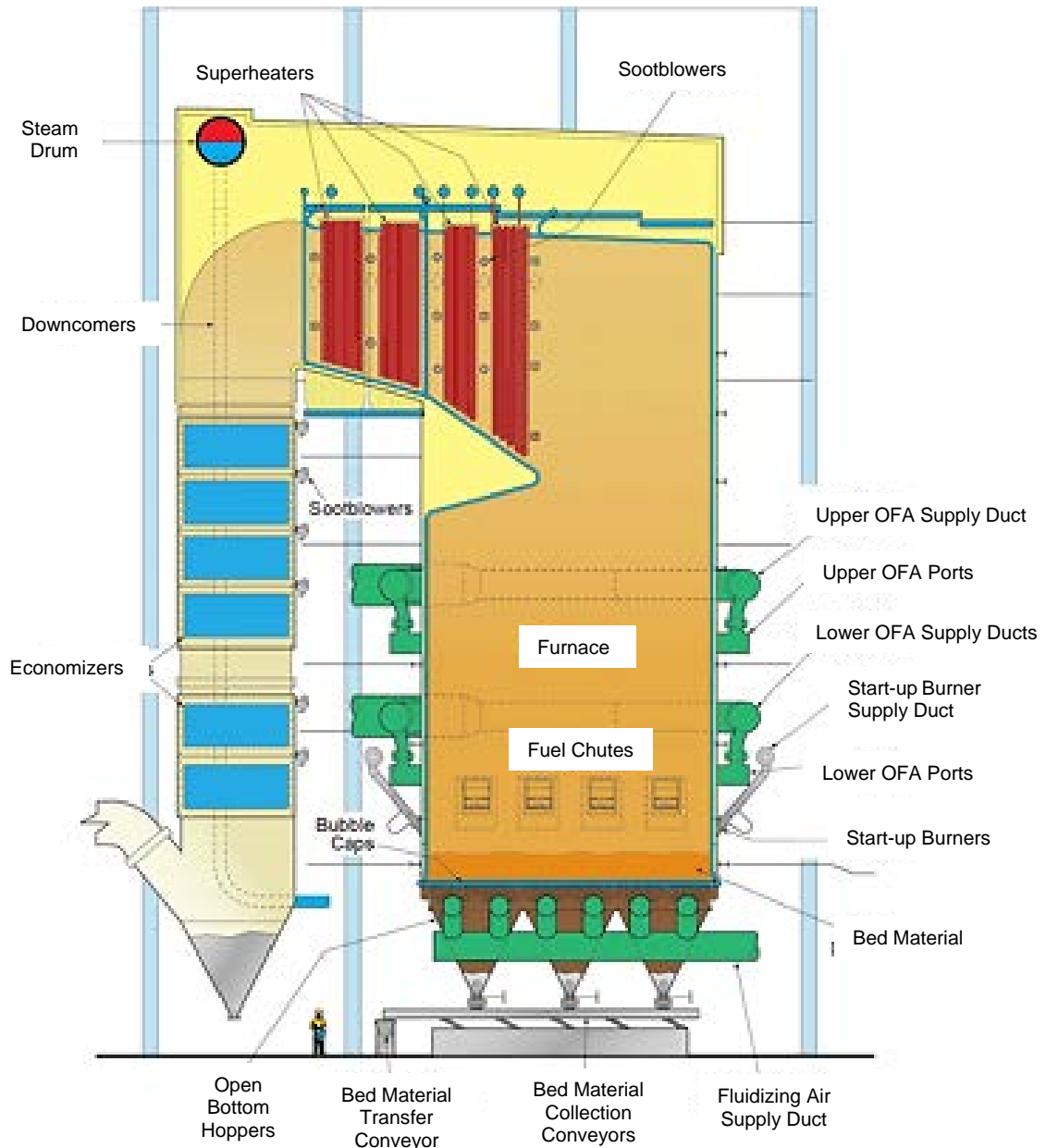

Babcock &amp; Wilcox Top-Supported BFB Boiler

**Source:** Babcock & Wilcox, *BFB-boiler-top-supported*, ND. Digital Image. Reprinted with permission from Babcock & Wilcox. Retrieved from Babcock.com, <https://www.babcock.com/products/bubbling-fluidized-bed-boilers> (accessed June 5, 2019).

The plant performance estimates for BFB boilers firing wood chips is highly dependent on fuel moisture. Generally, BFB boiler efficiencies range from 75% to 80%. The estimated net heat rate firing wood chips is 13,300 Btu/kWh based on the HHV of the fuel.



### 13.1.2 Electrical & Control Systems

The electrical system for this case includes the turbine generator which is connected via generator circuit breakers to a GSU. The GSU increases the voltage from the generator voltages level to the transmission system high voltage level. The facility and most of the subsystems are controlled using a central DCS. Some systems are controlled using programmable logic controllers, and these systems include the sootblower system, the fuel handling system, and the ash handling system

### 13.1.3 Offsite Requirements

The facility is constructed on a greenfield site of approximately 50 acres. Wood chips are delivered to the facility by truck and rail. The maximum daily rate for wood chips for the facility is approximately 1500 tons per day.

Water for steam cycle makeup and cooling tower makeup is assumed to be sourced from onsite wells. Wastewater generated from the water treatment systems and the cooling tower blow down is sent to the adjacent waterway from one or more outfalls from a water treatment pond or wastewater treatment system.

The electrical interconnection costs are based on a one-mile distance from the facility switchyard to the terminal point on an existing utility substation. For the purposes of this estimate, the cost associated with the expansion of the substation is excluded.

## 13.2 CAPITAL COST ESTIMATE

The base cost estimate for this technology case totals \$4097/kW. Table 13-1 summarizes the cost components for this case. The basis of the estimate assumes that the site is constructed in a United States region that has good access to lower cost construction labor and has reasonable access to well water and/or water resources, locally sourced wood chips, and existing utility transmission substations or existing transmission lines. The geographic location is assumed to be characterized by seismic, wind, and other loading criteria that do not add significantly to the capital costs. An outdoor installation is assumed, meaning that the boiler building is not enclosed. No special systems are needed to prevent freezing or to account for snow loads on structures.



Table 13-1 — Case 13 Capital Cost Estimate

Case 13 EIA – Capital Cost Estimates – 2019 \$s		
<b>Configuration</b>	<b>50-MW Biomass Plant</b>	
<b>Combustion Emissions Controls</b>	Bubbling Fluidized Bed	
<b>Post-Combustion Emissions Controls</b>	OFA	
<b>Fuel Type</b>	SCR / Baghouse	
	Woodchips	
	<b>Units</b>	
<b>Plant Characteristics</b>		
Net Plant Capacity (60 deg F, 60% RH)	MW	50
Heat Rate, HHV Basis	Btu/kWh	13300
<b>Capital Cost Assumptions</b>		
EPC Contracting Fee	% of Direct & Indirect Costs	10%
Project Contingency	% of Project Costs	12%
Owner's Services	% of Project Costs	7%
Estimated Land Requirement (acres)	\$	50
Estimated Land Cost (\$/acre)	\$	30,000
<b>Interconnection Costs</b>		
<i>Electrical Transmission Line Costs</i>	\$/mile	1,200,000
Miles	miles	1.00
Substation Expansion	\$	0
<i>Gas Interconnection Costs</i>		
Pipeline Cost	\$/mile	N/A
Miles	miles	N/A
Metering Station	\$	N/A
<b>Typical Project Timelines</b>		
Development, Permitting, Engineering	months	24
Plant Construction Time	months	36
Total Lead Time Before COD	months	60
Operating Life	years	40
<b>Cost Components (Note 1)</b>		<b>Breakout</b>
		<b>Total</b>
<i>Civil/Structural/Architectural Subtotal</i>	\$	22,266,000
Mechanical – Boiler Plant	\$	60,477,000
Mechanical – Turbine Plant	\$	8,230,000
Mechanical – Balance of Plant	\$	20,111,000
<i>Mechanical Subtotal</i>	\$	88,818,000
Electrical – Main and Auxiliary Power Systems	\$	3,543,000
Electrical – BOP and I&C	\$	17,657,000
Electrical – Substation and Switchyard	\$	5,408,000
<i>Electrical Subtotal</i>	\$	26,608,000
Project Indirects	\$	15,418,000
EPC Total Before Fee	\$	153,110,000
EPC Fee	\$	15,311,000
<b>EPC Subtotal</b>	\$	168,421,000
<b>Owner's Cost Components (Note 2)</b>		
Owner's Services	\$	11,789,000
Land	\$	1,500,000
Electrical Interconnection	\$	1,200,000
Gas Interconnection	\$	0
<b>Owner's Cost Subtotal</b>	\$	14,489,000
<b>Project Contingency</b>	\$	21,949,000
<b>Total Capital Cost</b>	\$	204,859,000
	<b>\$/kW net</b>	<b>4,097</b>



<b>Case 13 EIA – Capital Cost Estimates – 2019 \$s</b>	
<b>Configuration</b>	<b>50-MW Biomass Plant</b> Bubbling Fluidized Bed OFA SCR / Baghouse Woodchips
<b>Combustion Emissions Controls</b>	
<b>Post-Combustion Emissions Controls</b>	
<b>Fuel Type</b>	
<b>Capital Cost Notes</b>	
<p>1. Costs based on EPC contracting approach. Direct costs include equipment, material, and labor to construct the civil/structural, mechanical, and electrical/I&amp;C components of the facility. Indirect costs include distributable material and labor costs, cranes, scaffolding, engineering, construction management, startup and commissioning, and contractor overhead. EPC fees are applied to the sum of direct and indirect costs.</p> <p>2. Owner's costs include project development, studies, permitting, legal, owner's project management, owner's engineering, and owner's startup and commissioning costs. Other owner's costs include electrical interconnection costs, gas interconnection costs (if applicable), and land acquisition costs.</p>	

### 13.3 O&M COST ESTIMATE

The O&M costs for 50-MW biomass wood-fired generation facility are summarized in Table 13-2. The fixed costs cover the O&M labor, contracted maintenance services and materials, and G&A. Major overhauls for the facility are generally based on a three-year basis for boiler equipment and firing equipment and a six-year basis for the steam turbine. Shorter outages (e.g., change out SCR catalyst) are generally performed on a two-year cycle.

Non-fuel variable costs for this case include SCR catalyst replacement costs, SCR reagent costs, water treatment costs, wastewater treatment costs, fly ash and bottom ash disposal costs, bag replacement for the fabric filters, and bed material makeup.



Table 13-2 — Case 13 O&amp;M Cost Estimate

Case 13 EIA – Non-Fuel O&M Costs – 2019 \$s		
50-MW Biomass Plant		
<b>Fixed O&amp;M – Plant (Note 1)</b>		
Labor	\$/year	3,510,000
Materials and Contract Services	\$/year	1,250,000
Administrative and General	\$/year	<u>1,526,000</u>
Subtotal Fixed O&M	\$/year	6,286,000
\$/kW-year	\$/kW-year	<b>125.72 \$/kW-year</b>
<b>Variable O&amp;M (Note 2)</b>	\$/MWh	<b>4.83 \$/MWh</b>
<b>O&amp;M Cost Notes</b>		
1. Fixed O&M costs include labor, materials and contracted services, and G&A costs. O&M costs exclude property taxes and insurance.		
2. Variable O&M costs include catalyst replacement, ammonia, water, ash disposal, and water discharge treatment cost.		

### 13.4 ENVIRONMENTAL & EMISSIONS INFORMATION

The emissions for the major criteria pollutants are summarized in Table 13-3. The NO<sub>x</sub> emissions assume that the in-furnace controls such as LNB, OFA, and SCR systems are employed to control emissions to 0.08 lb/MMBtu. The SO<sub>2</sub> emissions from wood fired combustion are assumed to be negligible and are uncontrolled. The CO<sub>2</sub> emissions estimates are based on emissions factors listed in Table C-1 of 40 CFR 98, Subpart C.

Table 13-3 — Case 13 Emissions

Case 13 EIA – Emissions Rates		
50-MW Biomass Plant		
<b>Predicted Emissions Rates (Note 1)</b>		
NO <sub>x</sub>	lb/MMBtu	0.08 (Note 2)
SO <sub>2</sub>	lb/MMBtu	<0.03 (Note 3)
PM	lb/MMBtu	0.03 (Note 4)
CO <sub>2</sub>	lb/MMBtu	206 (Note 5)
<b>Emissions Control Notes</b>		
1. Wood Fuel – 20% to 50% Fuel Moisture		
2. NO <sub>x</sub> Removal using OFA, and SCR		
3. SO <sub>2</sub> is assumed negligible in for wood fuel		
4. Controlled using pulse jet fabric filter		
5. Per 40 CFR 98, Subpt. C, Table C-1		



## CASE 14. 10% BIOMASS CO-FIRE RETROFIT

### 14.1 CASE DESCRIPTION

This case is a retrofit of an existing 300-MW pulverized coal power facility to cofire wood biomass at a rate corresponding to 10% of the equivalent output in MW. In this scenario, the biomass fuel displaces coal to generate approximately 30 MW of the net output with the balance from coal. The type of boiler assumed for the retrofit is a balanced draft, radiant reheat type boiler that fires a high to medium sulfur bituminous coal through pulverizers. The firing system is either tangential or wall-fired and is assumed to have low-NO<sub>x</sub> features such as LNBS and OFA. The biomass is a pelletized wood-based material formed from sawdust or paper. The biomass is not mixed with the coal and is not fed through the pulverizers but is introduced into the boiler through separate burners in new water-wall openings. The heat input from the biomass displaces the equivalent heat input from coal.

#### 14.1.1 Mechanical Equipment & Systems

Figure 14-1 summarizes schematically the equipment required for the retrofit of biomass cofiring equipment to an existing 300-MW coal-fired facility. A portion of the facility is modified to receive and store the biomass fuel. The biomass fuel storage area is constructed on a concrete pad and a roof to minimize exposure to rain and snow. A reclaim system will convey the fuel to a grinder and feeder system located near the boiler. The biomass is then fed into surge bins feeding four individual burners. The biomass is conveyed to the boiler with heated primary air. The biomass burners have windboxes for secondary air distribution. The boiler water walls are modified to account for the new biomass firing equipment.

The BOP equipment modifications include additional fire detection and protection equipment. Additional duct control equipment is provided to minimize dangerous accumulation of fines. Additional automated and manual wash water systems are provided to remove any dust accumulation along the material handling path. Additional sootblowers are included in areas of the upper furnace and convective passes to address increases in fouling and slagging by the cofiring of the wood biomass. No modifications to the boiler post-combustion emissions controls are necessary; however, the boiler controls are modified to account for the redistribution of combustion air.

The introduction of biomass into the boiler will decrease the boiler efficacy. The estimated increase in heat rate for the 100% coal-fired base case is approximately 1.5%.



**Figure 14-1 — Biomass Cofiring in Coal-Fired Boilers, Separate Feed Arrangement**

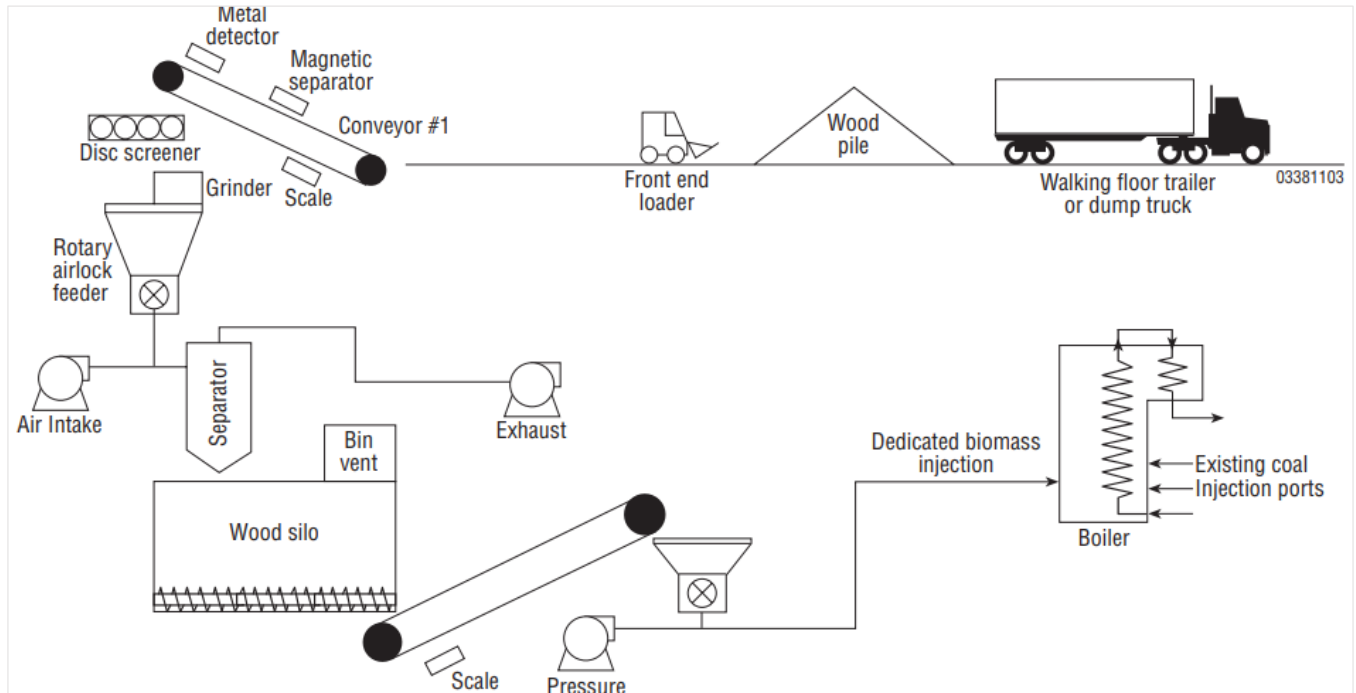

Source: NREL, *DOE/EE-0288 Biomass Cofiring in Coal-Fired Boilers*, 2004. PDF.  
Retrieved from NREL.gov, <https://www.nrel.gov/docs/fy04osti/33811.pdf> (accessed June 13, 2019).

### 14.1.2 Electrical & Control Systems

No major modifications to the electrical system are needed for this retrofit; however, new power feeds to the biomass fuel handling equipment and biomass conveying fans will be required. The plant DCS system will be upgraded to accommodate the additional input/output and control systems for the biomass handling and combustions systems.

### 14.1.3 Offsite Requirements

The pelletized wood biomass is delivered to the facility by truck. The maximum daily biomass fuel rate for the facility is approximately 500 tons per day, which corresponds to 20 to 24 trucks per day. New roads and additional site access are provided to accommodate the increase in daily truck traffic.

There are no substantial increases in the demands of cycle makeup water or cooling tower makeup. The service water demands increase due to the additional washdown systems needed for dust control, but the current water resources are sufficient to meet these demands.



## 14.2 CAPITAL COST ESTIMATE

The base cost estimate for this technology case totals \$705/kW based on the net output from the biomass; in this case, it is 30 MW. Table 14-1 summarizes the cost components for this case. The basis of the estimate assumes that the site has sufficient space for the biomass fuel storage and sufficient auxiliary power capacity for the new electrical loads.

**Table 14-1 — Case 14 Capital Cost Estimate**

Case 14 EIA – Capital Cost Estimates – 2019 \$s		
<b>Configuration</b>		<b>10% Biomass Co-Fire Retrofit</b>
<b>Combustion Emissions Controls</b>		300-MW PC Boiler
<b>Post-Combustion Emissions Controls</b>		LNB / OFA / SCR
<b>Fuel Type</b>		ESP
		Wood Pellets, up to 10%
<b>Units</b>		
<b>Plant Characteristics</b>		
Equivalent Biomass Plant Capacity	MW	30
Heat Rate, HHV Basis	% Change from Baseline	+ 1.5%
<b>Capital Cost Assumptions</b>		
EPC Contracting Fee	% of Direct & Indirect Costs	10%
Project Contingency	% of Project Costs	20%
Owner's Services	% of Project Costs	7%
Estimated Land Requirement (acres)	\$	0
Estimated Land Cost (\$/acre)	\$	30,000
<b>Interconnection Costs</b>		
<i>Electrical Transmission Line Costs</i>		
Electrical Transmission Line Costs	\$/mile	1,200,000
Miles	miles	1.00
Substation Expansion	\$	N/A
<i>Gas Interconnection Costs</i>		
Pipeline Cost	\$/mile	N/A
Miles	miles	N/A
Metering Station	\$	N/A
<b>Typical Project Timelines</b>		
Development, Permitting, Engineering	months	18
Plant Construction Time	months	8
Total Lead Time Before COD	months	26
Operating Life	years	20
<b>Cost Components (Note 1)</b>		<b>Total</b>
<i>Civil/Structural/Architectural Subtotal</i>	\$	1,572,000
<i>Mechanical Subtotal</i>	\$	9,880,000
<i>Electrical Subtotal</i>	\$	2,769,000
Project Indirects	\$	749,000
EPC Total Before Fee	\$	14,970,000
EPC Fee	\$	1,497,000
<b>EPC Subtotal</b>	\$	<b>16,467,000</b>



Case 14 EIA – Capital Cost Estimates – 2019 \$\$		
Configuration	10% Biomass Co-Fire Retrofit	
Combustion Emissions Controls	300-MW PC Boiler	
Post-Combustion Emissions Controls	LNB / OFA / SCR	
Fuel Type	ESP	
	Wood Pellets, up to 10%	
<b>Units</b>		
<b>Owner's Cost Components (Note 2)</b>		
Owner's Services	\$	1,153,000
Land	\$	0
Electrical Interconnection	\$	0
Gas Interconnection	\$	0
<b>Owner's Cost Subtotal</b>	<b>\$</b>	<b>1,153,000</b>
<b>Project Contingency</b>	<b>\$</b>	<b>3,524,000</b>
<b>Total Capital Cost</b>	<b>\$</b>	<b>21,144,000</b>
<b>\$/kW net</b>		<b>705</b>
<b>Capital Cost Notes</b>		
<p>1. Costs based on EPC contracting approach. Direct costs include equipment, material, and labor to construct the civil/structural, mechanical, and electrical/I&amp;C components of the facility. Indirect costs include distributable material and labor costs, cranes, scaffolding, engineering, construction management, startup and commissioning, and contractor overhead. EPC fees are applied to the sum of direct and indirect costs.</p> <p>2. Owner's costs include project development, studies, permitting, legal, owner's project management, owner's engineering, and owner's startup and commissioning costs. Other owner's costs include electrical interconnection costs, gas interconnection costs (if applicable), and land acquisition costs.</p>		

### 14.3 O&M COST ESTIMATE

The O&M costs for biomass cofiring are summarized in Table 14-2. Costs are normalized by the equivalent electrical output from biomass. The fixed costs cover the O&M labor, contracted maintenance services and materials, and G&A for the cofiring systems only.

Non-fuel variable costs for this technology case include increased water treatment costs and increased fly ash and bottom ash disposal costs.

**Table 14-2 — Case 14 O&M Cost Estimate**

Case 14 EIA – Non-Fuel O&M Costs – 2019 \$\$		
10% Biomass Co-Fire Retrofit		
<b>Fixed O&amp;M – Plant (Note 1)</b>		
Labor	\$/year	267,000
Materials and Contract Services	\$/year	350,000
Administrative and General	\$/year	<u>150,000</u>
Subtotal Fixed O&M	\$/year	767,000
\$/kW-year	\$/kW-year	<b>25.57 \$/kW-year</b>
<b>Variable O&amp;M (Note 2)</b>	\$/MWh	<b>1.90 \$/MWh</b>
<b>O&amp;M Cost Notes</b>		
<p>1. Fixed O&amp;M costs include labor, materials and contracted services, and G&amp;A costs. O&amp;M costs exclude property taxes and insurance.</p> <p>2. Variable O&amp;M costs include water, ash disposal, and water discharge treatment cost.</p>		



#### 14.4 ENVIRONMENTAL & EMISSIONS INFORMATION

The emissions for the major criteria pollutants are summarized in Table 14-3. No major modifications to the emissions controls system are required; however, the combustion air and OFA distribution within the furnace need to be tuned and adjusted to optimize the performance on the biomass fuel. The NO<sub>x</sub> emissions as measured at the outlet of the economizer are expected to decrease by up to 20% from baseline levels depending on the type of boiler and the coal fired. The SO<sub>2</sub> emissions are expected to decrease by approximately 8%. and the CO<sub>2</sub> emissions derived from coal reduce by approximately 8% from baseline levels.

**Table 14-3 — Case 14 Emissions**

Case 14			
EIA – Emissions Offsets			
10% Biomass Co-Fire Retrofit			
Predicted Emissions Rates (Note 1)			
NO <sub>x</sub>	% change at Economizer Outlet	- 0 to -20% (Note 2)	
SO <sub>2</sub>	% change at Economizer Outlet	-8%	
PM	% change at Economizer Outlet	0%	
CO <sub>2</sub> (Derived from Coal)	% change at Economizer Outlet	-8% (Note 3)	
Emissions Control Notes			
1. Emissions are presented as differentials to the baseline, uncontrolled emissions rates			
2. In-furnace NO <sub>x</sub> reduction systems in place; LNBS and OFA			
3. Based on a reduction of the coal derived CO <sub>2</sub>			



## CASE 15. GEOTHERMAL PLANT, 50 MW

### 15.1 CASE DESCRIPTION

This case is a hydrothermal-based net 50-MW geothermal power plant using a binary cycle. Capital costs for geothermal power are highly site specific and technology specific. There are two distinct types of geothermal systems: Enhanced Geothermal System (EGS) and Hydrothermal. EGS technology uses fractures, or porous characteristics, in dry, hot rock to create a geothermal reservoir by injecting the water into the hot rock before commercial operation. Hydrothermal systems use naturally occurring geothermal aquifers that already have hot liquid water and/or steam within fractured or porous reservoirs.

Either type of geothermal system can use one of three general technologies for the generation of electricity: dry, flash, and binary cycle. The choice of technology is usually based on the temperature of the water (liquid, steam, or both) found within the geothermal reservoir (or the temperature of the EGS-developed reservoir). In some cases, these technologies may be combined, such as a flash plant with a bottoming binary cycle. Dry steam technology is used with geothermal reservoirs that produce superheated, dry steam that self-discharges from the production well. These systems are typically reserved for the upper range of reservoir temperatures. Flash technology is used with geothermal reservoirs that produce steam and water. The steam and water are separated at the surface with the steam being routed to a steam generator and the liquid either being reinjected into the well or being flashed into steam by a pressure reduction before being routed to a steam generator. This case assumes the use of the third technology: binary cycle.

The use of a binary cycle rather than flash would typically be considered for geothermal production temperatures of 350°F or less, although there is no firm temperature demarcation point as to when binary versus flash technologies should be used. Reservoirs with lower temperatures (approximately 350°F or less) will typically be produced via wells that will not self-discharge and require a means of pumping the fluid from the reservoir up to the surface. This pumping is usually accomplished using individual pumps installed into each production well. The binary cycle is also commonly referred to as Organic Rankine Cycle.

When using a binary cycle, the produced reservoir fluid is maintained as a pressurized liquid (i.e., at a pressure above the saturation pressure corresponding to the fluid's temperature) within the production well, the surface piping and plant equipment, all the way to the injection wells where it is readmitted to



the reservoir. This pressurized state keeps the hot geothermal fluid from boiling (flashing), and the geothermal fluid is never in contact with ambient air. A portion of the heat content of the pressurized geothermal fluid is transferred into a working fluid via one or more heat exchanger(s). The working fluid is typically vaporized within the heat exchanger(s) and is then sent to a turboexpander where it expands and produces mechanical power. The turboexpander drives an electrical generator. Binary cycle power plants may use either air-cooling or water-cooling for condensing the turbo-expander exhaust back into a liquid. Currently, most geothermal plants operating within the United States use flash steam technology; however, this case assumes the use of binary cycle technology due to the lower temperatures of remaining unused geothermal resources.

Utility-scale geothermal power requires high-temperature aquifers to be cost effective. Locating aquifers with a sufficiently high temperature and sustainable flow rate is a significant task. The costs associated with exploration and drilling of the wells often accounts for over 50% of the total overnight capital expenditures for a geothermal project. To isolate the costs of building and maintaining the geothermal plant itself, this study has assumed that the geothermal plant was built on a brownfield site. This means that a sufficiently hot aquifer has already been identified with production and injection wells already developed. While this is rare, it does occasionally occur within the industry. As the geothermal well gets hotter, lower flow rates are required to maintain the same output thus reducing capital costs and operation costs. This analysis assumes that the geothermal reservoir has a temperature of 300°F.

### 15.1.1 Mechanical Equipment & Systems

A binary cycle power plant has three independent fluid loops: (1) the geothermal fluid loop, (2) the closed working fluid loop, and (3) the open cooling water loop. A simplified image of binary cycle including loops (1) and (2) can be seen in Figure 15-1. The open geothermal loop is comprised of the production well(s), downhole well pump(s), piping to the power plant, heat exchanger(s) coupled with the working fluid, piping to the injection well field, and the injection well(s). The temperature and flow rate of the geothermal loop is dependent upon the properties of the reservoir, but it is always kept at a pressure above its flash point. A single geothermal production well typically has the potential to convert the well's thermal power into around 3 MW of electric power. A geothermal plant typically has between a 2:1 ratio and a 1:1 ratio of production wells to injection wells. This system is assumed to have 17 production wells and 10 injections wells.

The closed working fluid loop is comprised of a pump for pumping the working fluid in the liquid phase, a turboexpander that is connected to a generator, and heat exchanger(s). Heat exchangers transfer heat

from the hot geothermal fluid to the working fluid, essentially boiling the working fluid and the resulting vapor is sent through the turboexpander. After the turboexpander, another heat exchanger (condenser) transfers heat from the working vapor, condensing it back into a liquid to be pumped back through the cycle. The working fluid typically has a low boiling point, which allows for reliable operation, and has a high conversion efficiency for good utilization of the geothermal heat. The 50-MW geothermal plant uses two working fluid loops, each with its own 25-MW steam turbine and generator.

Figure 15-1 — Geothermal Binary Cycle Power Plant

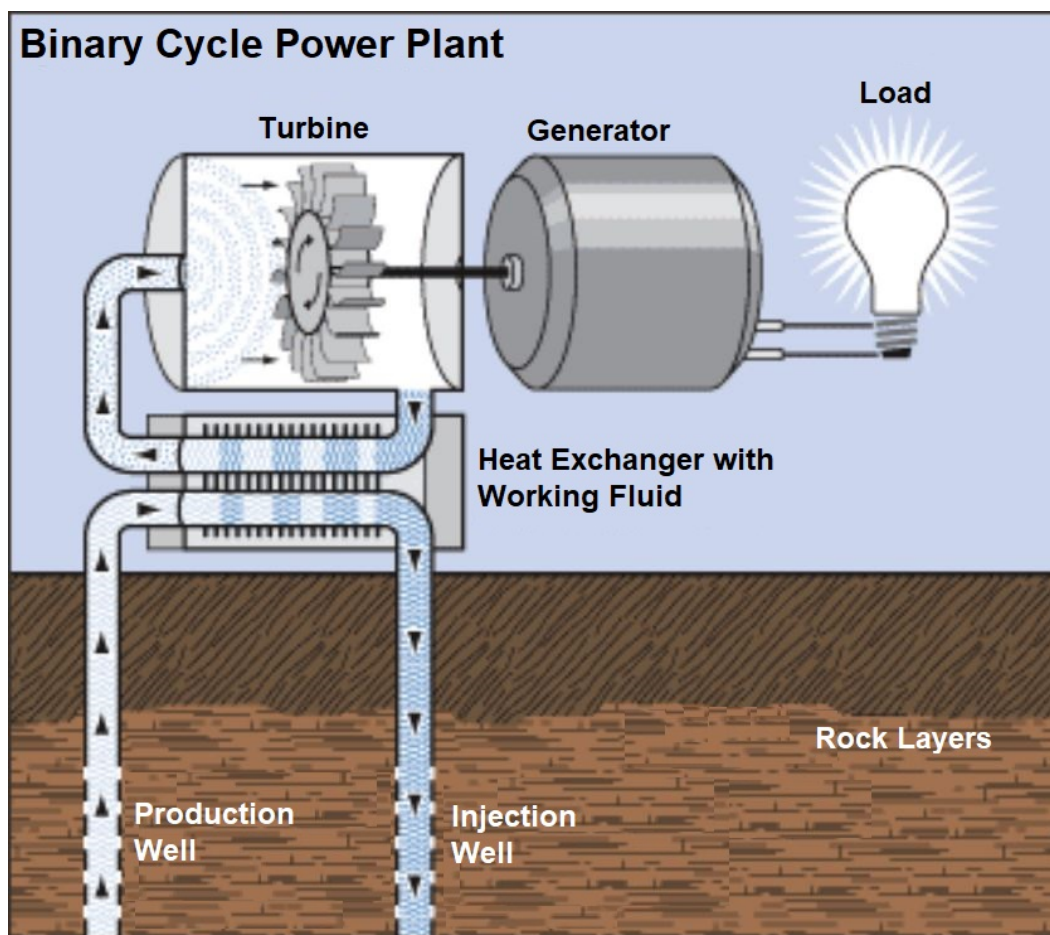

Source: Office of Energy Efficiency & Renewable Energy, Geothermal Technologies Office – U.S. Department of Energy, *binaryplant*, ND. Digital Image Retrieved from Energy.gov, <https://www.energy.gov/eere/geothermal/electricity-generation> (accessed July 9, 2019)

The final loop, which is not shown in the diagram above, is an open loop of cooling water which is comprised of a cooling water pump, heat exchanger (condenser), and the cooling tower. The cooling system used for this case is a wet cooling tower. Water vapor from the cooling tower is the only emission of binary cycle power plants, with the exception of a cooling water blowdown stream from the cooling



tower. Air-cooled condensers can also be used, but risk declines in power output during periods of high ambient temperature.

### **15.1.2 Electrical & Control Systems**

This 50-MW geothermal plant uses two 25-MW turboexpanders with independent generators. Each generator has its own step-up transformer and circuit breaker. After the circuit breaker, each electrical connection is combined via a high-voltage bus into a high-voltage circuit breaker before being fed into the grid.

### **15.1.3 Offsite Requirements**

Geothermal plants use renewable heat from within the earth and naturally occurring water sources. This allows geothermal facilities to be free from requiring offsite fuel or materials. Water for the cooling system is either sourced from offsite or uses nearby natural sources such as a lake, freshwater well, or river. Unlike dry steam and flash power plants, binary cycle plants continually reinject all of the produced geothermal fluid back into the reservoir, thereby removing the need for brine processing and disposal. This reinjection of all produced mass also helps in maintaining reservoir pressure since there is no net mass removal from the reservoir.

## **15.2 CAPITAL COST ESTIMATE**

The base cost estimate for this technology case totals \$2521/kW. Table 15-1 summarizes the cost components for this case. This price is dependent on the technology used, reservoir temperature, and location of the power plant. This analysis assumes that due to geological constraints, only the west coast of the United States should be considered for this cost estimate (i.e., California, Oregon, Washington, Nevada, and Idaho).





Table 15-1 — Case 15 Capital Cost Estimate

Case 15 EIA – Capital Cost Estimates – 2019 \$\$			
Configuration	Geothermal		
Plant Configuration	50 MW Binary Cycle		
Units			
<b>Plant Characteristics</b>			
Net Plant Capacity	MW	50	
<b>Capital Cost Assumptions</b>			
EPC Contracting Fee	% of Direct & Indirect Costs	15%	
Project Contingency	% of Project Costs	8%	
Owner's Services	% of Project Costs	12%	
Estimated Land Requirement (acres)	\$	200	
Estimated Land Cost (\$/acre)	\$	10,000	
<b>Electric Interconnection Costs</b>			
Transmission Line Cost	\$/mile	1,200,000	
Miles	miles	1.00	
Substation Expansion	\$	0	
<b>Typical Project Timelines</b>			
Development, Permitting, Engineering	months	24	
Plant Construction Time	months	36	
Total Lead Time Before COD	months	60	
Operating Life	years	40	
<b>Cost Components (Note 1)</b>		<b>Breakout</b>	<b>Total</b>
<i>Civil/Structural/Architectural Subtotal</i>	\$	8,463,000	
Mechanical – Steam Turbine	\$	18,750,000	
Mechanical – Production / Injection System	\$	21,644,000	
Mechanical – Balance of Plant	\$	19,663,000	
<b>Mechanical Subtotal</b>	\$	60,057,000	
Electrical – BOP and I&C	\$	5,475,000	
Electrical – Substation and Switchyard	\$	4,302,000	
<b>Electrical Subtotal</b>	\$	9,777,000	
Project Indirects	\$	9,838,000	
EPC Total Before Fee	\$	88,135,000	
EPC Fee	\$	13,220,000	
<b>EPC Subtotal</b>	\$	101,355,000	
<b>Owner's Cost Components (Note 2)</b>			
Owner's Services	\$	12,163,000	
Land	\$	2,000,000	
Electrical Interconnection	\$	1,200,000	
<b>Owner's Cost Subtotal</b>	\$	15,363,000	
<b>Project Contingency</b>	\$	9,337,000	
<b>Total Capital Cost</b>	\$	126,055,000	
<b>\$/kW net</b>			<b>2,521</b>
<b>Capital Cost Notes</b>			
<p>1. Costs based on EPC contracting approach. Direct costs include equipment, material, and labor to construct the civil/structural, mechanical, and electrical/I&amp;C components of the facility. Indirect costs include distributable material and labor costs, cranes, scaffolding, engineering, construction management, startup and commissioning, and contractor overhead. EPC fees are applied to the sum of direct and indirect costs.</p> <p>2. Owner's costs include project development, studies, permitting, legal, owner's project management, owner's engineering, and owner's startup and commissioning costs. Other owner's costs include electrical interconnection costs, gas interconnection costs (if applicable), and land acquisition costs.</p>			



### 15.3 O&M COST ESTIMATE

Different geothermal technologies have different O&M costs. Binary cycle geothermal plants are able to maintain the turbine (turboexpander) at a lower cost than other geothermal technologies due to the increased quality of the working fluid compared to the geothermal steam that passes through the turbine in dry steam and flash plant designs. What binary cycle plants save in turbine maintenance is lost in the additional pump maintenance since the other technologies do not require downhole pumps. Additionally, for binary cycle plants to produce equivalent net power outputs, they require higher flow rates from the production wells and have more overall pumps and piping compared to the other geothermal technologies.

**Table 15-2 — Case 15 O&M Cost Estimate**

<b>Case 15</b>		
<b>EIA – Non-Fuel O&amp;M Costs – 2019 \$s</b>		
Geothermal		
<b>Fixed O&amp;M – Plant (Note 1)</b>		
Labor	\$/year	1,470,000
Steam Turbine Maintenance	\$/year	3,750,000
Materials and Contract Services	\$/year	661,800
Administrative and General	\$/year	<u>545,400</u>
Subtotal Fixed O&M	\$/year	6,427,200
\$/kW-year	\$kW-year	<b>128.54 \$/kW-year</b>
<b>Variable O&amp;M (Note 2)</b>	\$/MWh	<b>1.16 \$/MWh</b>
<b>O&amp;M Cost Notes</b>		
1. Fixed O&M costs include labor, materials and contracted services, and G&A costs. O&M costs exclude property taxes and insurance.		
2. Variable O&M costs include catalyst replacement, ammonia, limestone, water, ash disposal, FGD waste disposal, and water discharge treatment cost.		

### 15.4 ENVIRONMENTAL & EMISSIONS INFORMATION

While flash and dry geothermal power plants produce small emissions, binary cycle geothermal plants produce no regulated environmental emissions. The only emission is water vapor and small amounts of blowdown tower water from the cooling tower because the working fluid is kept in a closed loop and the geothermal loop is only open to the underground reservoir. Therefore, the emissions of NO<sub>x</sub>, SO<sub>2</sub>, and CO<sub>2</sub> are 0.00 lb/MMBtu.



## **CASE 16. INTERNAL COMBUSTION ENGINES, LANDFILL GAS, 30 MW**

### **16.1 CASE DESCRIPTION**

This case is a landfill gas-fired power plant that is powered by four reciprocating internal combustion engines. Each engine is nominally rated at 9.1 MW for a net capacity of 35.6 MW. The case only includes the power block and does not include any of the landfill gas gathering or filtering systems.

#### **16.1.1 Mechanical Equipment and Systems**

The RICE power plant comprises four large-scale gas-fired engines that are coupled to a generator. The power plant also includes the necessary engine auxiliary systems, which are fuel gas, lubricated oil, compressed air, cooling water, air intake, and exhaust gas.

Each engine is comprised of 10 cylinders in a V configuration. The engines are a four-stroke, spark-ignited engine that operates on the Otto cycle. Each engine includes a turbocharger with an intercooler that uses the expansion of hot exhaust gases to drive a compressor that raises the pressure and density of the inlet air to each cylinder. The turbocharger is an axial turbine/compressor with the turbine and the centrifugal compressor mounted on the same shaft. Heat generated by compressing the inlet air is removed by a water-cooled “intercooler.” Turbocharging increases the engine output due to the denser air/fuel mixture.

The engines are cooled using a water/glycol mixture that circulates through the engine block, cylinder heads, and the charge air coolers. The cooling system is a closed-loop system and is divided into a high-temperature and a low-temperature circuit. The high-temperature circuit cools the engine block, cylinder heads, and the first stage of the charge air cooler. The low-temperature cooler cools the second stage of the charge air cooler. Heat is rejected from the cooling water system by air-cooled radiators.

#### **16.1.2 Electrical and Control Systems**

The electrical generator is coupled to the engine. The generator is a medium voltage, air-cooled, synchronous AC generator.



The engine OEM provides a DCS that allows for a control interface, plant operating data, and historian functionality. The control system is in an onsite building. Programmable logic controllers are also provided throughout the plant for local operation.

### 16.1.3 Offsite Requirements

Fuel for combustion is delivered through the landfill gas gathering system. As water consumption is minimal at the power plant, water is obtained from the municipal water supply. The power plant also includes minimal water treatment for onsite water usage. Wastewater is treated using an oil-water separator and then is directed to a municipal wastewater system. Used oil that is no longer filterable is stored in a waste oil tank and removed offsite with a vacuum truck.

The power plant's onsite switchyard is connected to the transmission system through a nearby substation.

## 16.2 CAPITAL COST ESTIMATE

The base cost estimate for this technology case totals \$1563/kW. Table 19-1 summarizes the cost components for this case.

**Table 16-1 — Case 16 Capital Cost Estimate**

Case 16 EIA – Capital Cost Estimates – 2019 \$s		
Configuration	Internal Combustion Engines	
Fuel Type	4 x 9.1 MW Landfill Gas	
Units		
<b>Plant Characteristics</b>		
Net Plant Capacity (60 deg F, 60% RH)	MW	35.6
Net Plant Heat Rate, HHV Basis	Btu/kWh	8513
<b>Capital Cost Assumptions</b>		
EPC Contracting Fee	% of Direct & Indirect Costs	10%
Project Contingency	% of Project Costs	8%
Owner's Services	% of Project Costs	7.5%
Estimated Land Requirement (acres)	\$	10
Estimated Land Cost (\$/acre)	\$	30,000
<b>Interconnection Costs</b>		
<i>Electrical Transmission Line Costs</i>		
	\$/mile	720,000
Miles	miles	1.00
Substation Expansion	\$	0
<i>Gas Interconnection Costs</i>		
Pipeline Cost	\$/mile	0
Miles	miles	0.00
Metering Station	\$	0
<b>Typical Project Timelines</b>		



<b>Case 16</b>		
<b>EIA – Capital Cost Estimates – 2019 \$s</b>		
Configuration	<b>Internal Combustion Engines</b>	
Fuel Type	4 x 9.1 MW Landfill Gas	
<b>Units</b>		
Development, Permitting, Engineering	months	12
Plant Construction Time	months	18
Total Lead Time Before COD	months	30
Operating Life	years	30
<b>Cost Components (Note 1)</b>	<b>Breakout</b>	<b>Total</b>
<i>Civil/Structural/Architectural Subtotal</i>	\$	12,464,000
Engines (Note 3)	\$	13,637,000
Mechanical BOP	\$	8,735,000
<i>Mechanical Subtotal</i>	\$	22,372,000
<i>Electrical Subtotal</i>	\$	9,803,000
Project Indirects	\$	180,000
EPC Total Before Fee	\$	31,182,000
EPC Fee	\$	3,118,000
<b>EPC Subtotal</b>	<b>\$</b>	<b>34,300,000</b>
<b>Owner's Cost Components (Note 2)</b>		
Owner's Services	\$	2,573,000
Land	\$	300,000
Owner Furnished Equipment (Note 3)	\$	13,637,000
Electrical Interconnection	\$	720,000
Gas Interconnection	\$	0
<b>Owner's Cost Subtotal</b>	<b>\$</b>	<b>17,230,000</b>
<b>Project Contingency</b>	<b>\$</b>	<b>4,122,000</b>
<b>Total Capital Cost</b>	<b>\$</b>	<b>55,652,000</b>
	<b>\$/kW net</b>	<b>1,563</b>
<b>Capital Cost Notes</b>		
<p>1. Costs based on EPC contracting approach. Direct costs include equipment, material, and labor to construct the civil/structural, mechanical, and electrical/I&amp;C components of the facility. Indirect costs include distributable material and labor costs, cranes, scaffolding, engineering, construction management, startup and commissioning, and contractor overhead. EPC fees are applied to the sum of direct and indirect costs.</p> <p>2. Owner's costs include project development, studies, permitting, legal, owner's project management, owner's engineering, and owner's startup and commissioning costs. Other owner's costs include electrical interconnection costs, gas interconnection costs (if applicable), and land acquisition costs.</p> <p>3. Engines and associated auxiliary procured from the engine OEM.</p>		

Owner's costs were reviewed to ensure that utility interconnection costs were accounted for appropriately. Specific to the landfill gas case, a natural gas interconnection for engine fuel is not required. Additionally, it is expected that some electrical and water utilities will already be available at the existing landfill site.

### 16.3 O&M COST ESTIMATE

The O&M cost estimate includes all tasks discussed in the O&M estimate description.

**Table 16-2 — Case 16 O&M Cost Estimate**

<b>Case 16</b>		
<b>EIA – Non-Fuel O&amp;M Costs – 2019 \$\$</b>		
Internal Combustion Engines		
<b>Fixed O&amp;M – Plant (Note 1)</b>		
Subtotal Fixed O&M	\$/kW-year	<b>20.10 \$/kW-year</b>
<b>Variable O&amp;M (Note 2)</b>		
	\$/MWh	<b>6.20 \$/MWh</b>
<b>O&amp;M Cost Notes</b>		
1. Fixed O&M costs include labor, materials and contracted services, and G&A costs. O&M costs exclude property taxes and insurance.		
2. Variable O&M costs include water, water discharge treatment cost, chemicals, and consumables.		

## 16.4 ENVIRONMENTAL & EMISSIONS INFORMATION

NO<sub>x</sub> and CO emissions are maintained through an SCR and CO catalyst installed in the exhaust system of each engine. SO<sub>2</sub> is uncontrolled but minimal and below emission limits because of the low amounts of SO<sub>2</sub> in the natural gas fuel. Water, wastewater, solid waste, and spent lubricating oil are disposed of through conventional means.

**Table 16-3 — Case 16 Emissions**

<b>Case 16</b>			
<b>EIA – Emissions Rates</b>			
Internal Combustion Engines			
<b>Predicted Emissions Rates – Natural Gas</b>			
NO <sub>x</sub>	lb/MMBtu	0.02 (Note 1)	
SO <sub>2</sub>	lb/MMBtu	0.00	
CO	lb/MMBtu	0.03	
CO <sub>2</sub>	lb/MMBtu	115 (Note 2)	
<b>Emissions Control Notes</b>			
1. With SCR			
2. Per 40 CFR98 Sub Part C – Table C1			

## CASE 17. HYDROELECTRIC PLANT, 100 MW

### 17.1 CASE DESCRIPTION

This case is based on a “New Stream Reach Development” 100-MW hydroelectric power plant with 75 feet of available head. Types of hydroelectric power plants including “run-of-river,” “storage,” and “pumped storage.” This case is based on a “storage” type hydropower plant that includes a dam to store water in a reservoir where water is released through tunnels to a powerhouse to spin a turbine.

Figure 17-1 shows a diagram of the major components of a storage-type hydroelectric power plant. The dam structure holds water in a reservoir. Water passes through an intake in the reservoir through the penstock. The penstock consists of concrete ‘power tunnels’ that direct water to a turbine that spins a generator that distributes electric power to the grid.

Case 17 is based on a concrete dam with a spillway and diversion tunnel to control the water level in the reservoir. There are two identical penstocks approximately 4.5 meters in diameter. Each penstock leads to a Francis-type hydro-turbine. Each of the two turbine-generators is rated for 50 MW. Power is stepped up from 13.8 kV to 154 kV for distribution.

**Figure 17-1 — Storage-Type Hydroelectric Power Plant**

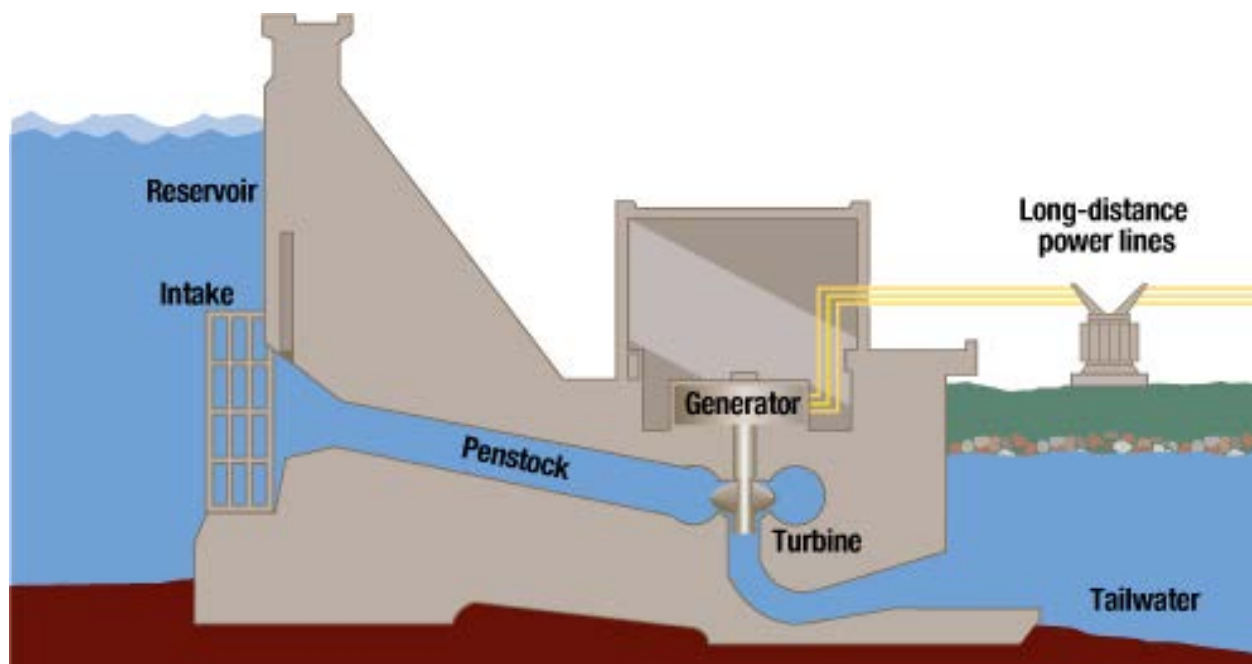

Source: Tennessee Valley Authority, How Hydroelectric Power Works, ND. Digital Image. Retrieved from TVA.gov, <https://www.tva.gov/Energy/Our-Power-System/Hydroelectric/How-Hydroelectric-Power-Works> (accessed June 13, 2019).

Figure 17-2 shows the dam and spill way of a storage-type hydroelectric power plant.

**Figure 17-2 — Dam and Spillway of Hydroelectric Power Plant**



**Source:** Tennessee Valley Authority, Cherokee, ND. Digital Image.  
Retrieved from TVA.gov, <https://www.tva.gov/Energy/Our-Power-System/Hydroelectric/Cherokee-Reservoir> (accessed June 13, 2019).

Figure 17-3 shows a typical turbine hall for a Francis-type hydropower turbine. The generator is located above the turbine and it connected to the same shaft.

**Figure 17-3 — Typical Hydroelectric Power Turbine Hall**



**Source:** Tennessee Valley Authority, Raccoon Mountain, ND. Digital Image.  
Retrieved from TVA.gov, <https://www.tva.gov/Energy/Our-Power-System/Hydroelectric/Raccoon-Mountain> (accessed July 8, 2019).





### 17.1.1 Offsite Requirements

The cost estimate assumes an allowance for a one-mile transmission line.

## 17.2 CAPITAL COST ESTIMATE

The base cost estimate for this technology case totals \$5316/kW. Table 17-1 summarizes the cost components for this case. The capital cost estimate is based on an EPC contracting approach. In addition to EPC contract costs, the estimate includes owner's costs that cover owner's services, project development costs, studies, permitting, legal, project management, owner's engineering, and start-up and commissioning.

**Table 17-1 — Case 17 Capital Cost Estimate**

Case 17 EIA – Capital Cost Estimates – 2019 \$s			
Configuration	Hydroelectric Power Plant New Stream Reach Development		
Units			
<b>Plant Characteristics</b>			
Net Power Rating	MW		100
Head	ft		75
<b>Capital Cost Assumptions</b>			
EPC Fee	% of Project Costs		10%
Project Contingency	% of Project Costs		10%
Owner's Services	% of Project Costs		7%
Estimated Land Requirement (Support buildings only)	acres		2
Estimated Land Cost	\$/acres		10,000
<b>Electric Interconnection Costs</b>			
Transmission Line Cost	\$/mile		1,200,000
Miles	miles		1.00
<b>Typical Project Timelines</b>			
Development, Permitting, Engineering	months		36
Plant Construction Time	months		36
Total Lead Time Before COD	months		72
Operating Life	years		50
<b>Cost Components</b>		<b>Breakout</b>	<b>Total</b>
<b>Direct Costs</b>			
Civil Structural Material and Installation	\$	247,865,000	
Mechanical Equipment Supply and Installation	\$	73,759,000	
Electrical / I&C Supply and Installation	\$	25,094,000	
<b>Direct Cost Subtotal</b>	\$		346,718,000
Project Indirects (Note 1)	\$		56,686,000
EPC Total Before Fee	\$		403,404,000
EPC Fee	\$		40,340,400
<b>EPC Subtotal</b>	\$		443,744,400



Case 17 EIA – Capital Cost Estimates – 2019 \$\$			
Configuration	Hydroelectric Power Plant New Stream Reach Development		
Units			
<b>Owner's Cost Components</b>			
Owner's Services	\$	38,351,000	
Land	\$	20,000	
Electrical Interconnection	\$	1,200,000	
<b>Owner's Cost Subtotal</b>	\$		39,571,000
<b>Project Contingency</b>	\$	48,332,000	48,332,000
<b>Total Capital Cost</b>	\$		<b>531,647,400</b>
			<b>\$/kW net</b>
			<b>5,316</b>
<b>Capital Cost Notes</b>			
1. Engineering, procurement, scaffolding, project services, construction management, field engineering, and startup and commissioning using EPC contracting.			
2. Project development, studies, permitting, legal, owner's project management, owner's engineering, and owner's participation in startup and commissioning. Excluded: Allowance for Funds Used During Construction, escalation excluded.			

### 17.3 O&M COST ESTIMATE

The O&M cost estimate incorporates the annual cost of the onsite O&M staff as well as contracted services for grounds keeping and computer maintenance. The estimate also covers the maintenance of the dam, spillway, penstock, turbine, generator, and BOP. The need for various consumables and replacement parts are also considered. The annual cost of consumables, such as lubricants, filters, chemicals, etc., is estimated as a fixed amount, so the variable cost component is considered to be zero. Total annual O&M costs for the New Stream Reach Development 100-MW hydroelectric power plant are summarized in Table 17-2.

**Table 17-2 — Case 17 O&M Cost Estimate**

Case 17 EIA – Non-Fuel O&M Costs – 2019 \$\$		
Hydroelectric Power Plant		
<b>Fixed O&amp;M – Plant (Note 1)</b>		
Subtotal Fixed O&M	\$/kW-year	<b>29.86 \$/kW-yr</b>
<b>Variable O&amp;M</b>	\$/MWh	<b>0.00 \$/MWh</b>
<b>O&amp;M Cost Notes</b>		
1. Fixed O&M costs include labor, materials and contracted services, and G&A costs. O&M costs exclude property taxes and insurance.		

### 17.4 ENVIRONMENTAL & EMISSIONS INFORMATION

Hydroelectric plants do not produce regulated environmental emission. While other environmental compliance requirements may apply, only air emissions were considered for this report. Therefore, the emissions of NO<sub>x</sub>, SO<sub>2</sub>, and CO<sub>2</sub> are 0.00 lb/MMBtu.



## **CASE 18. BATTERY ENERGY STORAGE SYSTEM, 50 MW / 200 MWH**

### **18.1 CASE DESCRIPTION**

This case consists of a utility-scale, lithium-ion, battery energy storage system (BESS) with a 50-MW power rating and 200-MWh energy rating; the system can provide 50 MW of power for a four-hour duration. Case 18 assumes that the BESS will be constructed close to an existing potential interconnection point such as grid or generator substation. The cost estimate includes a substation consisting of a transformer to step up from the BESS system to the interconnection voltage (480 V to 13.8 kV) and associated switchgear.

The BESS consists of 25 modular, pre-fabricated battery storage container buildings that contain the racks and appurtenances to store the initial set of batteries and accommodate battery augmentation for the life of the project. The BESS uses utility-scale lithium-ion batteries. Approximately 3% of the initial battery capacity is assumed to degrade each year and require augmentation by the addition of new batteries. (The augmentation cost is included with the annual O&M as discussed in Section 18.3.) Each battery container is equipped with fire detection and suppression systems and HVAC monitoring and control systems. The pre-fabricated battery containers are approximately 40 feet long x 10 feet wide x 8 feet high. Each battery container has an associated inverter-transformer building, which is approximately 20 feet long x 10 feet wide x 8 feet high. The inverter-transformer building houses the inverters, transformers, and associated electrical equipment for each battery container. There is one control building with approximate dimension of 20 feet long x 10 feet wide x 8 feet high to support O&M activities. Each building is set on a concrete slab foundation.

Figure 18-1 shows a typical utility-scale lithium-ion battery. Several battery cells make a battery module, which is independently monitored and controlled. Several battery modules are contained in a battery rack, and there are several battery racks in a battery container.

Figure 18-1 — Utility-Scale Lithium-Ion Batteries

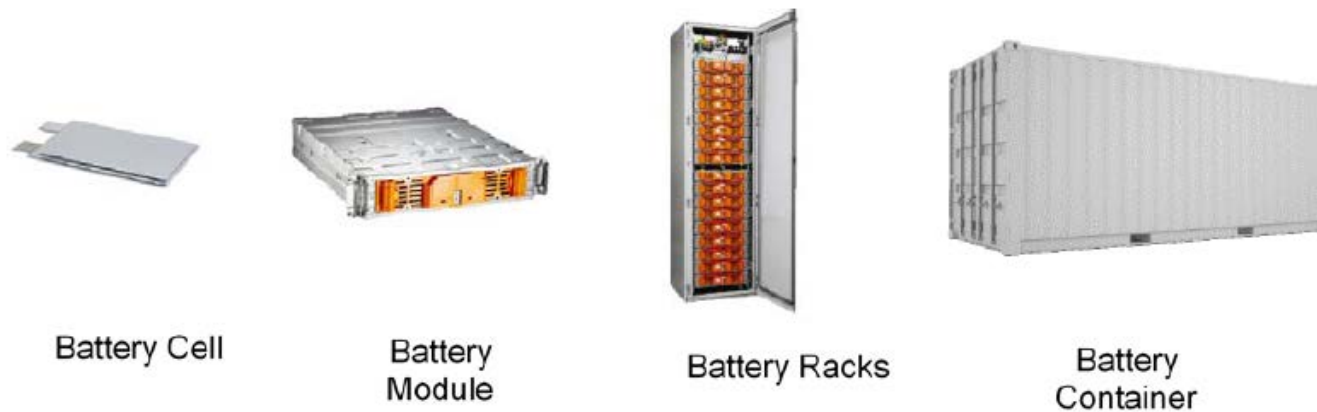

**Source:** National Renewable Energy Laboratory (NREL) "2018 U.S. Utility-Scale Photovoltaics-Plus-Energy Storage System Costs Benchmark, Technical Report NREL/TP-6A20-71714, November 2018. (<https://www.nrel.gov/docs/fy19osti/71714.pdf>) (accessed July 23, 2019)

The BESS is equipped with 200 MWh of lithium-ion batteries connected in strings and twenty-five 2-MW inverters. Battery energy storage systems are DC systems; however, most electric power generation is produced and distributed as AC power. The BESS is equipped with a power conversion system to convert between AC power for charging and distribution and DC power for storage. The power conversion system includes transformers and associated switchgear that supports battery charging and discharging by converting power between 13.8 kV and 480 V-direct-current. Power is provided by the BESS at a three-phase output voltage of 480 AC. The output voltage is stepped up by a transformer to 34.5 kV and connects to the grid at a substation. This interconnecting substation is not part of the project.

Figure 18-2 — BESS Flow Diagram

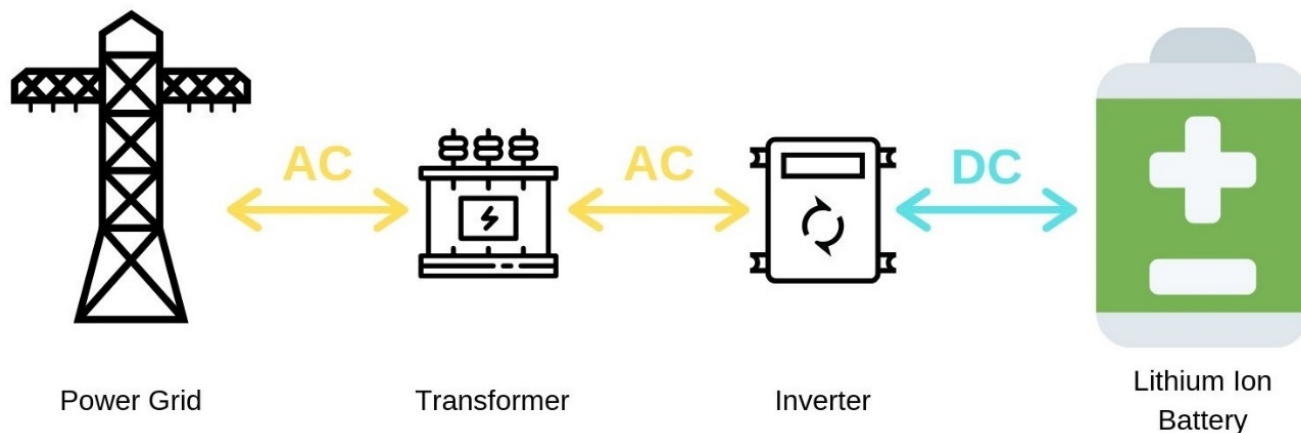

Each battery container is equipped with electronic protection such as current limiters, sensors, and disconnect switches to isolate strings of batteries. The BESS is equipped with multiple levels of monitoring and controls. Each battery module and battery string are monitored and can be controlled by its Battery Management Unit and Battery String Management Unit, respectively. The power conversion system is also monitored and controlled.

The BESS site is equipped with a Supervisory Control and Data Acquisition (SCADA) system that collects performance data from the Battery Management Units, Battery String Management Units, and power conversion system. The BESS can be monitored and controlled remotely through the SCADA system. Some BESS site may be programmed to respond to conditions in the grid through the SCADA system.

Figure 18-3 shows a cut-away view of a typical battery storage container.

**Figure 18-3 — Typical Battery Storage Container**

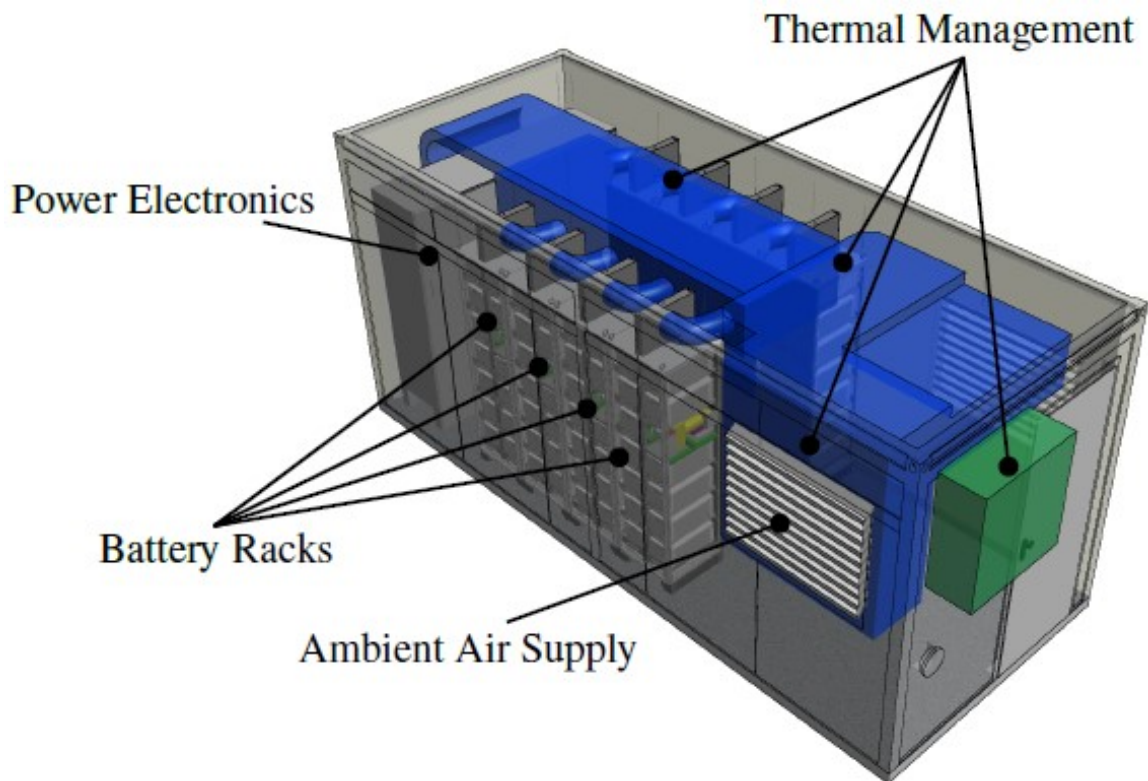

**Source:** Office of Scientific and Technical Information – U.S. Department of Energy, ND. Digital Image. Retrieved from OSTI.gov, <https://www.osti.gov/biblio/1409737> (accessed July 15, 2019).



### 18.1.1 Offsite Requirements

Typically, BESS projects are built at the site of existing generators or near substations where the system can easily tie into a grid for charging and discharging power. This cost estimate includes an allowance for a substation consisting of a transformer to step up to the distribution voltage (480 V to 13.8 kV), associated switchgear, and transmission line to nearby tie-in so that the BESS can receive and distribute 13.8 kV-alternating current power.

The capital cost estimate assumes that road access is available and does not include the cost to build roads. Our cost estimate does not include an allowance for onsite storage of tools, chemicals, or other O&M necessities. The O&M cost estimate assumes the O&M contractor will bring all necessities to the BESS site.

## 18.2 CAPITAL COST ESTIMATE

The base cost estimate for this technology case totals \$1389/kW or \$347/kWh. Both the \$/kW and \$/kWh are provided to clearly describe the system estimate. Table 18-1 summarizes the cost components for this case. The capital cost estimate is based on a BESS with a power rating of 50 MW and energy rating of 200 MWh (equivalent to a four-hour rating). The cost estimate includes civil works, foundations, buildings, electrical equipment and related equipment, substation, switchyard, transformers, transmission lines, cabling, controls, and instrumentation.

**Table 18-1 — Case 18 Capital Cost Estimate**

<b>Case 18</b>		
<b>EIA – Capital Cost Estimates – 2019 \$s</b>		
<b>Configuration</b>	<b>Battery Energy Storage System</b> 50 MW   200 MWh Greenfield	
<b>Battery Type</b>	Lithium-ion	
<b>Service Life</b>	10 years	
<b>Total Charging Cycles in Service Life</b>	3,000	
<b>Units</b>		
<b>Plant Characteristics</b>		
Power Rating	MW	50
Energy Rating	MWh	200
Duration	hour	4
<b>Capital Cost Assumptions</b>		
EPC Contracting Fee	% of Project Costs	5%
Project Contingency	% of Project Costs	5%
Owner's Services	% of Project Costs	4%
Estimated Land Requirement	acre	2
Estimated Land Cost	\$/acre	30,000



<b>Case 18</b>			
<b>EIA – Capital Cost Estimates – 2019 \$\$</b>			
<b>Configuration</b>	<b>Battery Energy Storage System</b> 50 MW   200 MWh Greenfield		
<b>Battery Type</b>	Lithium-ion		
<b>Service Life</b>	10 years		
<b>Total Charging Cycles in Service Life</b>	3,000		
<b>Units</b>			
<i>Electric Interconnection Costs</i>			
Transmission Line Cost	\$/mile	1,200,000	
Miles	miles	0.00	
<i>Typical Project Timelines</i>			
Development, Permitting, Engineering	months	4	
Plant Construction Time	months	6	
Total Lead Time Before COD	months	10	
<b>EPC Cost Components (Note 1)</b>		<b>Breakout</b>	<b>Total</b>
<i>Civil/Structural/Architectural Subtotal</i>		\$	8,314,000
Batteries	\$	40,037,000	
Inverters	\$	5,237,000	
Grounding Wiring, Lighting, Etc.	\$	254,000	
Transformers	\$	533,000	
Cable	\$	618,000	
<i>Electrical Subtotal</i>		\$	46,679,000
Raceway, Cable tray & Conduit	\$	258,000	
Control & Instrumentation	\$	22,000	
Transformer Switchgear, Circuit Breaker & Transmission Line	\$	305,000	
<i>Other Equipment &amp; Material Subtotal</i>		\$	585,000
Project Indirects	\$	4,595,000	
EPC Total Before Fee	\$	60,173,000	
EPC Fee	\$	3,009,000	
<b>EPC Subtotal</b>		\$	<b>63,182,000</b>
<b>Owner's Cost Components (Note 2)</b>			
Owner's Services	\$	2,906,000	
Land	\$	60,000	
Electrical Interconnections (Note 3)	\$	0	
<b>Owner's Cost Subtotal</b>		\$	<b>2,966,000</b>
<b>Project Contingency</b>		\$	<b>3,308,000</b>
<b>Total Capital Cost</b>		\$	<b>69,456,000</b>
		<b>\$/kW net</b>	<b>1,389</b>
		<b>\$/kWh</b>	<b>347</b>
<b>Capital Cost Notes</b>			
<p>1. Costs based on EPC contracting approach. Direct costs include equipment, material, and labor to construct the civil/structural, mechanical, and electrical/I&amp;C components of the facility. Indirect costs include distributable material and labor costs, cranes, scaffolding, engineering, construction management, startup and commissioning, and contractor overhead. EPC fees are applied to the sum of direct and indirect costs.</p> <p>2. Owner's costs include project development, studies, permitting, legal, owner's project management, owner's engineering, and owner's startup and commissioning costs. Other owner's costs include electrical interconnection costs, gas interconnection costs (if applicable), and land acquisition costs.</p> <p>3. The BESS is assumed to be located sufficient close to an existing substation, such that any transmission costs are covered in the project electrical equipment cost. A separate electric transmission cost is not necessary.</p>			



### 18.3 O&M COST ESTIMATE

The O&M cost estimate considers the ongoing O&M cost through the life of a BESS project. The service life of a BESS depends on how it is used. This case assumes that the BESS will have a service life of 3000 full charge-discharge cycles, which is a relatively typical basis in the industry. A full charge-discharge cycle occurs when a battery is fully charged, demand requires the full discharge of the energy, and then the battery is fully charged again. A service life of 3000 full cycles in a 10-year period equates to slightly fewer than 1 cycle per day. BESS projects that serve ancillary markets may not experience full charge and discharge cycle every day or may experience partial charge cycles. and The BESS service life depends on the charge and discharge pattern; therefore, a system that experiences partial charge cycles or multiple full cycles each day will have a different service life than described. The 3000 full-cycle service life is a typical industry basis to determine the cost and technical specifications for an energy storage system.

Many BESS projects engage a third-party contractor to conduct regular O&M activities. This cost estimate considers the cost of such contracted services, which include remote monitoring of the system, periodic onsite review of equipment conditions and cable connections, grounds maintenance, and labor involved in battery augmentation. During the service life of a BESS, a percentage of the batteries are expected to significantly decrease in efficiency or stop functioning. Instead of removing and replacing those batteries, BESS are designed with excess racking to accommodate additional batteries to augment the lost capacity. The entire BESS will be removed when it is decommissioned at the end of its service life. This approach reduces the costs associated with removing and transporting failed batteries each year. Typically, BESS designs estimate that approximately 3% of the battery capacity will be needed to be augmented each year. This O&M cost estimate uses the 3% battery augmentation factor and incorporates that cost in the annual fixed O&M cost. The O&M cost include an annual allowance for G&A costs. The fixed O&M costs are \$24.80/kW-year. The variable costs are \$0.00/MWh, since there are no consumables linked to energy output. Augmentation is included with fixed cost in this case since the case assumes the same number of charging cycles each year during the service life of the project.

The O&M costs do not include the cost of energy to charge the system.





Table 18-2 — Case 18 O&amp;M Cost Estimate

<b>Case 18</b>		
<b>EIA – Non-Fuel O&amp;M Costs – 2019 \$s</b>		
Battery Energy Storage System - 50 MW   200 MWh - Greenfield		
<b>Fixed O&amp;M – Plant (Note 1)</b>		
General & Administrative and Contract Services (Remote monitoring, on-site O&M, battery augmentation labor, grounds keeping, etc.)	\$/year	70,000
Battery Augmentation	\$/year	<u>1,170,000</u>
Subtotal Fixed O&M	\$/year	1,240,000
\$/kW-year	\$/kW-year	<b>24.80 \$/kW-year</b>
<b>Variable O&amp;M (Note 2)</b>	\$/MWh	<b>0.00 \$/MWh</b>
<b>O&amp;M Cost Notes</b>		
1. Fixed O&M costs include labor, materials and contracted services, and G&A costs. O&M costs exclude property taxes and insurance.		
2. All costs tied to energy produced are covered in fixed cost.		

## 18.4 ENVIRONMENTAL & EMISSIONS INFORMATION

Battery energy storage systems do not produce regulated environmental emission. While other environmental compliance requirements may apply, only air emissions were considered for this report. Therefore, the emissions of NO<sub>x</sub>, SO<sub>2</sub>, and CO<sub>2</sub> are 0.00 lb/MMBtu.



## **CASE 19. BATTERY ENERGY STORAGE SYSTEM, 50 MW / 100 MWh**

### **19.1 CASE DESCRIPTION**

This case is nearly identical to Case 18 with the exception that this is a BESS system with half the energy rating (100 MWh) and therefore half the duration (two hours). Since the energy rating for this case is half of Case 18, there will be half as many batteries. Therefore, this case will also have half as many battery containers. Case 19 assumes lithium-ion batteries are used, and the cost of civil works, foundations, buildings, electrical equipment and related equipment, substation, switchyard, transformers, transmission lines, cabling, and controls and instrumentation are included in the cost estimate. Case 19 assumes 3% of the initial set of batteries will require augmentation each year.

Refer to Case 18 for a more in-depth description of BESSs.

#### **19.1.1 Offsite Requirements**

Typically, BESS projects are built at the site of existing generators or near substations where the system can easily tie into a grid for charging and discharging power. This cost estimate includes an allowance for a substation consisting of a transformer to step up to the distribution voltage (480 V to 13.8 kV), associated switchgear, and transmission line to nearby tie-in so that the BESS can receive and distribute 13.8 kV-alternating current power.

### **19.2 CAPITAL COST ESTIMATE**

The base cost estimate for this technology case totals \$845/kW or \$423/kWh. Both the \$/kW and \$/kWh are provided to clearly describe the system estimate. Table 19-1 summarizes the cost components for this case. The capital cost estimate is based on a BESS with a power rating of 50 MW and energy rating of 100 MWh. Therefore, the BESS provides 50 MW of power for a duration of two hours. The capital cost estimate is based on an EPC contracting approach.

Typical project-related costs are included, such as owner's services, project development costs, studies, permitting, legal, project management, owner's engineering, and start-up and commissioning.



Table 19-1 — Case 19 Capital Cost Estimate

Case 19 EIA – Capital Cost Estimates – 2019 \$s		
Configuration	<b>Battery Energy Storage System</b> 50 MW   100 MWh Greenfield	
Battery Type	Lithium-ion	
Service Life	10 years	
Total Charging Cycles in Service Life	3,000	
<b>Units</b>		
<b>Plant Characteristics</b>		
Power Rating	MW	50
Energy Rating	MWh	100
Duration	hour	2
<b>Capital Cost Assumptions</b>		
EPC Contracting Fee	% of Project Costs	5%
Project Contingency	% of Project Costs	5%
Owner's Services	% of Project Costs	4%
Estimated Land Requirement	acre	1.2
Estimated Land Cost	\$/acre	30,000
<i>Electric Interconnection Costs (Note 1)</i>		
Transmission Line Cost	\$/mile	1,200,000
Miles	miles	0.00
<i>Typical Project Timelines</i>		
Development, Permitting, Engineering	months	4
Plant Construction Time	months	5
Total Lead Time Before COD	months	9
<b>Cost Components (Notes 1)</b>		<b>Breakout</b>
		<b>Total</b>
<i>Civil/Structural/Architectural Subtotal</i>	\$	6,071,000
Batteries	\$	20,019,00
Inverters	\$	5,237,000
Grounding Wiring, Lighting, Etc.	\$	143,000
Transformers	\$	533,000
Cable	\$	370,000
<i>Electrical Equipment Subtotal</i>	\$	26,302,000
Raceway, Cable tray & Conduit	\$	155,000
Control & Instrumentation	\$	22,000
Transformer Switchgear, Circuit Breaker & Transmission Line	\$	305,000
<i>Other Equipment &amp; Material Subtotal</i>	\$	482,000
Project Indirects	\$	3,679,000
EPC Total Before Fee	\$	36,534,000
EPC Fee	\$	1,827,000
<b>EPC Subtotal</b>	<b>\$</b>	<b>38,361,000</b>
<b>Owner's Cost Components (Note 2)</b>		
Owner's Services	\$	1,850,000
Land	\$	36,000
Electrical Interconnection Cost (Note 3)	\$	0
<b>Owner's Cost Subtotal</b>	<b>\$</b>	<b>1,886,000</b>
<b>Project Contingency</b>	<b>\$</b>	<b>2,013,000</b>
<b>Total Capital Cost</b>	<b>\$</b>	<b>42,260,000</b>
	\$/kW net	845
	\$/kWh	423



Case 19 EIA – Capital Cost Estimates – 2019 \$s	
<b>Configuration</b>	<b>Battery Energy Storage System</b> 50 MW   100 MWh Greenfield
<b>Battery Type</b>	Lithium-ion
<b>Service Life</b>	10 years
<b>Total Charging Cycles in Service Life</b>	3,000
<b>Capital Cost Notes</b>	
<p>1. Costs based on EPC contracting approach. Direct costs include equipment, material, and labor to construct the civil/structural, mechanical, and electrical/I&amp;C components of the facility. Indirect costs include distributable material and labor costs, cranes, scaffolding, engineering, construction management, startup and commissioning, and contractor overhead. EPC fees are applied to the sum of direct and indirect costs.</p> <p>2. Owner's costs include project development, studies, permitting, legal, owner's project management, owner's engineering, and owner's startup and commissioning costs. Other owner's costs include electrical interconnection costs, gas interconnection costs (if applicable), and land acquisition costs.</p> <p>3. The BESS is assumed to be located sufficient close to an existing substation, such that any transmission costs are covered in the project electrical equipment cost. A separate electric transmission cost is not necessary.</p>	

### 19.3 O&M COST ESTIMATE

The O&M cost estimate considers the ongoing O&M cost through the life of a BESS project. As mentioned in Case 18, the service life of a BESS depends on how it is used. This case assumes that the BESS will have a service life of 3000 full charge-discharge cycles, which is a relatively typical basis in the industry. A full charge-discharge cycle occurs when a battery is fully charged, demand requires the full discharge of the energy, and then the battery is fully charged again. A service life of 3000 full cycles in a 10-year period equates to slightly fewer than 1 cycle per day. BESS projects that serve ancillary markets may not experience a full charge and discharge cycle every day or may experience partial charge cycles. The BESS service life depends on the charge and discharge pattern; therefore, a system that experience partial charge cycles or multiple cull cycles each day will have a different service life than described. The service life of 3000 full cycles is a typical industry basis to determine the cost and technical specifications for an energy storage system.

Many BESS projects engage a third-party contractor to conduct regular O&M activities. This cost estimate considers the cost of such contracted services, which include remote monitoring of the system, periodic onsite review of equipment conditions and cable connections, grounds maintenance, and labor involved in battery augmentation. During the service life of a BESS, a percentage of the batteries are expected to significantly decrease in efficiency or stop functioning. Instead of removing and replacing those batteries, BESS are designed with excess racking to accommodate additional batteries to augment the lost capacity. This approach reduces the costs associated with removing and transporting failed batteries each year. Typically, BESS designs estimate that approximately 3% of the total number of batteries installed will need to be augmented each year. The entire BESS will be removed when it is



decommissioned at the end of its service life. This O&M cost estimate uses the 3% battery augmentation factor and incorporates that cost in the annual fixed O&M cost. The O&M cost includes an annual allowance for G&A costs. The fixed costs are \$12.90/kW-year. The variable costs are \$0.00/MWh, since there are no consumables linked to energy output. Augmentation is included with fixed cost in this case since the case assumes the same number of charging cycles each year during the service life of the project.

The O&M costs do not include the cost of energy to charge the system.

**Table 19-2 — Case 19 O&M Cost Estimate**

<b>Case 19</b>		
<b>EIA – Non-Fuel O&amp;M Costs – 2019 \$s</b>		
Battery Energy Storage System - 50 MW   100 MWh – Greenfield		
<b>Fixed O&amp;M – Plant (Note 1)</b>		
General & Administrative and Contract Services (Remote monitoring, on-site O&M, battery augmentation labor, grounds keeping, etc.)	\$/year	60,000
Battery Augmentation	\$/year	<u>585,000</u>
Subtotal Fixed O&M	\$/year	645,000
\$/kW-year	\$/kW-year	<b>12.90 \$/kW-year</b>
<b>Variable O&amp;M (Note 2)</b>	\$/MWh	<b>0.00 \$/MWh</b>
<b>O&amp;M Cost Notes</b>		
1. Fixed O&M costs include labor, materials and contracted services, and G&A costs. O&M costs exclude property taxes and insurance.		
2. All costs tied to energy produced are covered in fixed cost.		

## 19.4 ENVIRONMENTAL & EMISSIONS INFORMATION

Battery energy storage systems do not produce regulated environmental emission. While other environmental compliance requirements may apply, only air emissions were considered for this report. Therefore, the emissions of NO<sub>x</sub>, SO<sub>2</sub>, and CO<sub>2</sub> are 0.00 lb/MMBtu.



## **CASE 20.      ONSHORE WIND, LARGE PLANT FOOTPRINT, 200 MW**

### **20.1 CASE DESCRIPTION**

This case is an onshore wind power project located in the Great Plains region of the United States with a total project capacity of 200 MW. The Great Plains region, reflective of the central United States, has an abundance of land that is suitable for wind turbine siting and is generally not subject to land constraints that would otherwise limit project size.

### **20.2 MECHANICAL EQUIPMENT & SYSTEMS**

This Great Plains region onshore wind project is based on a 200 MW total project capacity. Parameters that affect project cost and performance include turbine nameplate capacity, rotor diameter, and hub height. The case configuration assumes 71 wind turbines with a nominal rating of 2.8 MW with a 125-meter rotor diameter, and a 90-meter hub height. These features reflect modern wind turbines that employ larger rotor diameter and greater hub heights. The primary advantage of taller hub heights and larger rotor diameters include access to better wind profiles at higher altitudes and increased turbine swept area, enabling the unit to capture more energy.

Wind turbine generators convert kinetic wind energy into electrical power. The most ubiquitous type of wind turbine used for electric power generation are those of the horizontal-axis three-bladed design. Lift is generated when wind flows around the turbine blades, resulting in rotation. The blades are connected to a central hub and drivetrain that turns a generator located inside of the nacelle, which is the housing positioned atop the wind turbine tower.

Figure 20-1 — Wind Turbine Generator Drivetrain

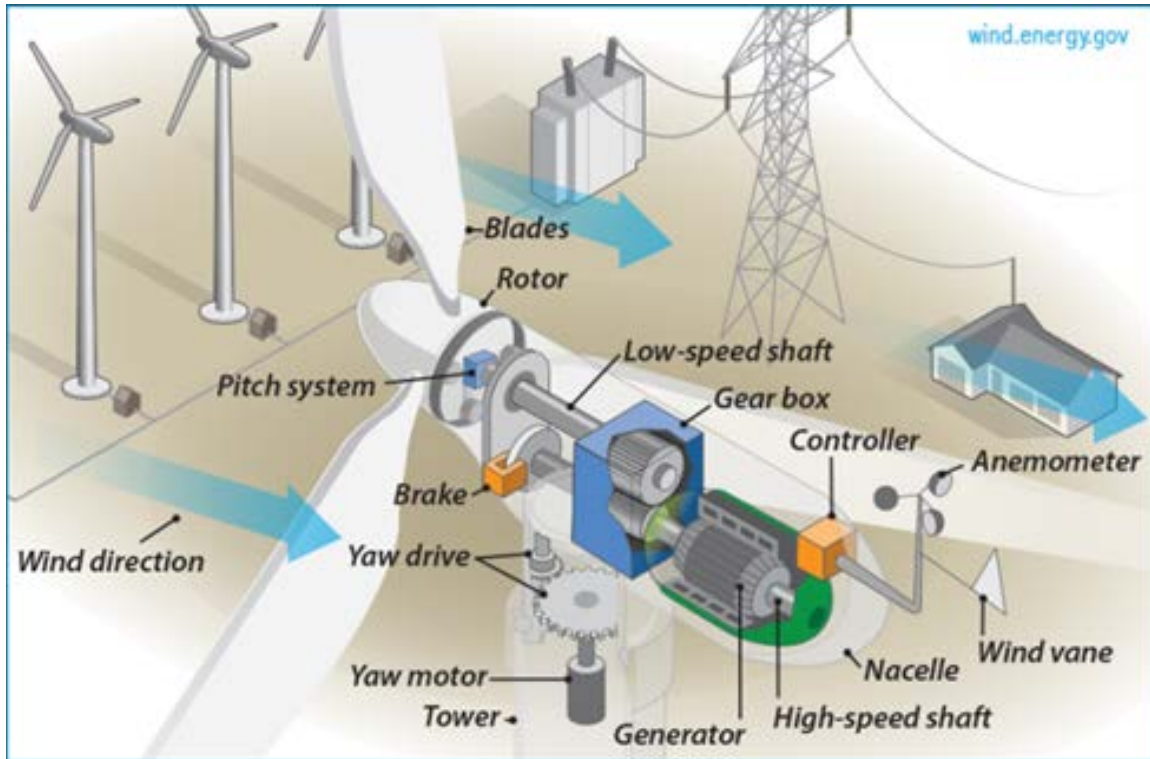

Source: Office of Energy Efficiency & Renewable Energy, Wind Energy Technologies Office – U.S. Department of Energy, *windTurbineLabels*, ND. Digital Image (Image 1 of 17). Retrieved from Energy.gov, <https://www.energy.gov/eere/wind/inside-wind-turbine> (accessed May 31, 2019).

### 20.2.1 Electrical & Control Systems

Each wind turbine generator (WTG) consists of a doubly-fed induction generator. The low-voltage output from the generator is stepped up to medium voltage through a transformer located either in the nacelle or at the tower base. A medium voltage collection system conveys the generated energy to an onsite substation that further steps up the voltage for interconnection with the transmission system with a voltage of 230 kV.

A SCADA system is provided for communications and control of the wind turbines and substation. The SCADA system allows the operations staff to remotely control and monitor each wind turbine and the wind project as a whole.

### 20.2.2 Offsite Requirements

Wind projects harness power from wind and therefore do not require fuel or fuel infrastructure. The offsite requirements are limited to construction of site and wind turbine access roads, the O&M building, and electrical interconnection to the transmission system.



## 20.3 CAPITAL COST ESTIMATE

The base cost estimate for this technology case totals \$1265/kW. Table 20-1 summarizes the cost components for this case.

Capital cost were broken down into the following categories:

- **Civil/Structural Costs:** These costs include the WTG spread footing and substation foundations, access roads, crane pads, road improvements, and O&M building.
- **Mechanical Costs:** These costs include the purchase price for the WTGs from the OEM (i.e., blades, hub, drivetrain, generator, tower, and electronics), transportation and delivery to the project site, and assembly and erection on site.
- **Electrical Costs:** These costs include pad-mounted transformers, underground collection system, and the project substation.
- **Project Indirect Costs:** These costs include construction management, engineering, and G&A costs.
- **EPC Fee:** The EPC fee is a markup charged by the construction contractor.
- **Project Contingency Costs:** Contingency is an allowance considered to cover the cost of undefined or uncertain scope of work, including EPC change orders or costs associated with schedule delays.
- **Owner Costs:** These costs include Project development costs that cover project feasibility analyses, wind resource assessments, geotechnical studies, contracting for land access, transmission access and permitting. However, estimates exclude project financing costs.

**Table 20-1 — Case 20 Capital Cost Estimate**

Case 20 EIA – Capital Cost Estimates – 2019 \$s		
Configuration	Onshore Wind – Large Plant Footprint: Great Plains Region 200 MW   2.8 MW WTG	
Hub Height (m)	90	
Rotor Diameter (m)	125	
<b>Units</b>		
<b>Plant Characteristics</b>		
Net Plant Capacity	MW	200
<b>Capital Cost Assumptions</b>		
EPC Contracting Fee	% of Direct & Indirect Costs	8%
Project Contingency	% of Project Costs	4%
Owner's Services	% of Project Costs	7%
<b>Electric Interconnection Costs</b>		
Transmission Line Cost	\$/mile	1,200,000
Miles	miles	1.00





<b>Case 20</b>			
<b>EIA – Capital Cost Estimates – 2019 \$\$</b>			
<b>Configuration</b>	<b>Onshore Wind – Large Plant Footprint: Great Plains Region</b>		
	200 MW   2.8 MW WTG		
<b>Hub Height (m)</b>	90		
<b>Rotor Diameter (m)</b>	125		
<b>Units</b>			
<i>Typical Project Timelines</i>			
Development, Permitting, Engineering	months	12	
Plant Construction Time	months	9	
Total Lead Time Before COD	months	21	
Operating Life	years	25	
<b>Cost Components (Note 1)</b>			<b>Total</b>
<i>Civil/Structural/Architectural Subtotal</i>			
WTG Procurement and Supply	\$	24,297,000	
WTG Erection	\$	155,209,000	
<i>Mechanical Subtotal</i>			
Electrical – Substation Electrical Equipment	\$	7,679,000	
Electrical – Pad Mount Transformers and Collection System	\$	10,711,000	
<i>Electrical Subtotal</i>			
Project Indirects	\$	5,183,000	
EPC Total Before Fee	\$	210,581,000	
EPC Fee	\$	16,846,000	
<i>EPC Subtotal</i>			
<b>Owner' Cost Components (Note 2)</b>			
<i>Owner's Cost Subtotal</i>			
\$ 15,919,890			
<i>Project Contingency</i>			
\$ 9,734,000			
<b>Total Capital Cost</b>			
<b>\$ 253,080,890</b>			
<b>\$/kW net</b>			<b>1,265</b>
<b>Capital Cost Notes</b>			
1. Costs based on EPC contracting approach. Direct costs include equipment, material, and labor to construct the civil/structural, mechanical, and electrical/I&C components of the facility. Indirect costs include distributable material and labor costs, cranes, scaffolding, engineering, construction management, startup and commissioning, and contractor overhead. EPC fees are applied to the sum of direct and indirect costs.			
2. Owner's costs include project development, studies, permitting, legal, owner's project management, owner's engineering, and owner's startup and commissioning costs. Other owner's costs include electrical interconnection costs.			

## 20.4 O&M COST ESTIMATE

O&M cost estimates reflect a full-service agreement arrangement under which an O&M contractor provides labor, management, and parts replacement (including unscheduled parts replacement) for the WTGs, collection system, and substation. Our cost estimate excludes site-specific owner's costs such as land lease royalties, property taxes, and insurance. However, average land lease cost in Great Plains region is \$2.84/kW-yr. Table 20-2 summarizes the average annual O&M expenses projected for an assumed 25-year project life.



Table 20-2 — Case 20 O&amp;M Cost Estimate

<b>Case 20</b>		
<b>EIA – Non-Fuel O&amp;M Costs – 2019 \$s</b>		
Onshore Wind – Large Plant Footprint: Great Plains Region		
<b>Fixed O&amp;M – Plant (Note 1)</b>		
WTG Scheduled Maintenance	\$/year	2,294,000
WTG Unscheduled Maintenance	\$/year	2,167,000
Balance of Plant Maintenance	\$/year	806,000
Subtotal Fixed O&M	\$/year	5,267,000
\$/kW-year	\$/kW-year	<b>26.34 \$/kW-year</b>
<b>Variable O&amp;M (Note 2)</b>	\$/MWh	<b>0.00 \$/MWh</b>
<b>O&amp;M Cost Notes</b>		
1. Fixed O&M costs include labor, materials and contracted services, and G&A costs.		
2. O&M Costs estimates reflect Full Service Agreement and exclude site specific owner's costs such as land lease, royalties, property taxes, and insurance. Average land lease costs in Great Plains region is \$2.80/kW-year.		
3. Average FSA term considered: 25 years		

## 20.5 ENVIRONMENTAL & EMISSIONS INFORMATION

Wind power projects do not produce regulated environmental air emissions. While other environmental compliance requirements may apply, only air emissions were considered for this report. Therefore, the emissions of NO<sub>x</sub>, SO<sub>2</sub>, and CO<sub>2</sub> are 0.00 lb/MMBtu.



## **CASE 21.      ONSHORE WIND, SMALL PLANT FOOTPRINT, 50 MW**

### **21.1 CASE DESCRIPTION**

This case is an onshore wind project with a total project capacity of 50 MW. “Coastal” refers to the area that is reflective of the Mid-Atlantic, Northeast, and Pacific regions of the United States. Due to assumed land availability constraints for this region, the project capacity is limited.

#### **21.1.1 Mechanical Equipment & Systems**

The onshore wind project in the Coastal region is based on a 50-MW total project capacity. Parameters that affect project cost and performance include turbine nameplate capacity, rotor diameter, and hub height. The case configuration assumes 17 wind turbines with a nominal rating of 2.8 MW with 125-meter rotor diameters and 90-meter hub heights. These features reflect modern wind turbines that employ larger rotor diameter and greater hub heights. The primary advantage of taller hub heights and larger rotor diameters include access to better wind profiles at higher altitudes and increased turbine swept area, enabling the unit to capture more energy.

Wind turbine generators convert kinetic wind energy into electrical power. The most ubiquitous type of wind turbine used for electric power generation are those of the horizontal-axis three-bladed design. Lift is generated when wind flows around the turbine blades, resulting in rotation. The blades are connected to a central hub and drivetrain that turns a generator located inside of the nacelle, which is the housing positioned atop the wind turbine tower.

Figure 21-1 — Wind Turbine Generator Drivetrain

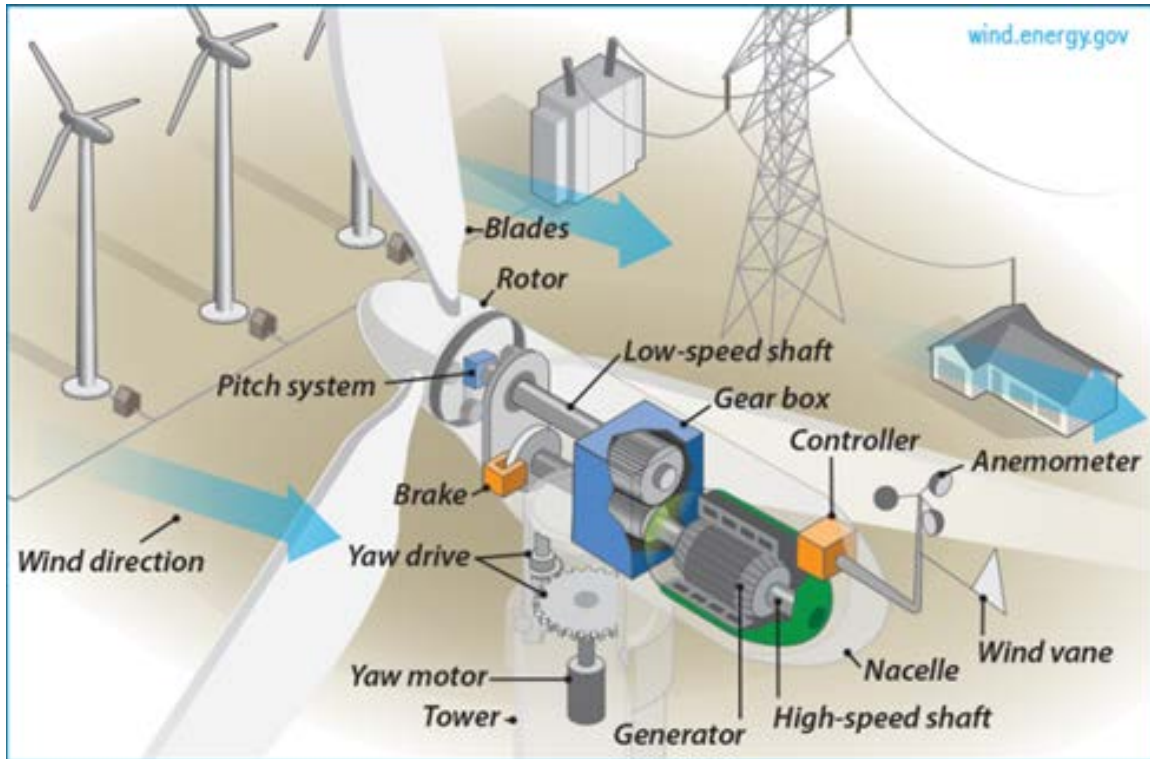

Source: Office of Energy Efficiency & Renewable Energy, Wind Energy Technologies Office – U.S. Department of Energy, *windTurbineLabels*, ND. Digital Image (Image 1 of 17). Retrieved from Energy.gov, <https://www.energy.gov/eere/wind/inside-wind-turbine> (accessed May 31, 2019).

### 21.1.2 Electrical & Control Systems

Each WTG consists of a doubly-fed induction generator. The low-voltage output from the generator is stepped up to medium voltage through a transformer located either in the nacelle or at the tower base. A medium voltage collection system conveys the generated energy to an onsite substation that further steps up the voltage for interconnection with the transmission system with a voltage of 230 kV.

A SCADA system is provided for communications and control of the wind turbines and substation. The SCADA system allows the operations staff to remotely control and monitor each wind turbine and the wind project as a whole.

### 21.1.3 Offsite Requirements

Wind projects harness power from wind and therefore do not require fuel or fuel infrastructure. The offsite requirements are limited to construction of site and wind turbine access roads, the O&M building, and electrical interconnection to the transmission system.



## 21.2 CAPITAL COST ESTIMATE

The base cost estimate for this technology case totals \$1677/kW. Table 21-1 summarizes the cost components for this case.

Capital cost estimates were broken down into the following categories:

- **Civil/Structural Costs:** These costs include the WTG spread footing and substation foundations, access roads, crane pads, road improvements, and O&M building.
- **Mechanical Costs:** These costs include the purchase price for the WTGs from the OEM (blades, hub, drivetrain, generator, tower, and electronics), transportation and delivery to the project site, and assembly and erection on site.
- **Electrical Costs:** These costs include pad-mounted transformers, collection system, and project substation.
- **Project Indirect Costs:** These costs include construction management, engineering, and G&A costs.
- **EPC Fee:** The EPC fee is a markup charged by the construction contractor.
- **Project Contingency Costs:** Contingency is an allowance considered to cover the cost of undefined or uncertain scope of work, including EPC change orders or costs associated with schedule delays.
- **Owner Costs:** These costs include Project development costs that cover project feasibility analyses, wind resource assessments, geotechnical studies, contracting for land access, transmission access, and permitting. However, estimates exclude project financing costs.

**Table 21-1 — Case 21 Capital Cost Estimate**

Case 21 EIA – Capital Cost Estimates – 2019 \$s		
Configuration	<b>Onshore Wind – Small Plant Footprint: Coastal Region</b> 50 MW   2.8 MW WTG	
Hub Height (m)	90	
Rotor Diameter (m)	125	
<b>Units</b>		
<b>Plant Characteristics</b>		
Net Plant Capacity	MW	50
<b>Capital Cost Assumptions</b>		
EPC Contracting Fee	% of Direct & Indirect Costs	8%
Project Contingency	% of Project Costs	6%
Owner's Services	% of Project Costs	10%
<b>Electric Interconnection Costs</b>		
Transmission Line Cost	\$/mile	1,200,000
Miles	miles	1.00



<b>Case 21 EIA – Capital Cost Estimates – 2019 \$\$</b>			
<b>Configuration</b>	<b>Onshore Wind – Small Plant Footprint: Coastal Region</b>		
	50 MW   2.8 MW WTG		
<b>Hub Height (m)</b>	90		
<b>Rotor Diameter (m)</b>	125		
<b>Units</b>			
<i>Typical Project Timelines</i>			
Development, Permitting, Engineering	months	12	
Plant Construction Time	months	6	
Total Lead Time Before COD	months	18	
Operating Life	years	25	
<b>Cost Components (Note 1)</b>			<b>Total</b>
<i>Civil/Structural/Architectural Subtotal</i>	\$	10,529,000	
WTG Procurement and Supply	\$	44,881,000	
Turbine Erection	\$	3,539,000	
<i>Mechanical Subtotal</i>	\$	48,419,000	
Electrical – Substation Electrical Equipment	\$	510,000	
Electrical – Pad Mount Transformers and Collection System	\$	3,495,000	
<i>Electrical Subtotal</i>	\$	6,005,000	
Project Indirects	\$	1,618,000	
EPC Total Before Fee	\$	66,571,000	
EPC Fee	\$	5,326,000	
<b>EPC Subtotal</b>	<b>\$</b>	<b>71,897,000</b>	
<b>Owner's Cost Subtotal (Note 2)</b>	<b>\$</b>	<b>7,189,700</b>	
<b>Project Contingency</b>	<b>\$</b>	<b>4,745,000</b>	
<b>Total Capital Cost</b>	<b>\$</b>	<b>83,831,700</b>	
			<b>1,677</b>
<b>\$/kW net</b>			
<b>Capital Cost Notes</b>			
1. Costs based on EPC contracting approach. Direct costs include equipment, material, and labor to construct the civil/structural, mechanical, and electrical/I&C components of the facility. Indirect costs include distributable material and labor costs, cranes, scaffolding, engineering, construction management, startup and commissioning, and contractor overhead. EPC fees are applied to the sum of direct and indirect costs.			
2. Owner's costs include project development, studies, permitting, legal, owner's project management, owner's engineering, and owner's startup and commissioning costs. Other owner's costs include electrical interconnection costs.			

### 21.3 O&M COST ESTIMATE

O&M cost estimates reflect a full-service agreement arrangement, under which an O&M contractor provides labor, management, and parts replacement (including unscheduled parts replacement) for the WTGs, collection system, and substation. Our cost estimates exclude site specific owner's costs such as land lease royalties, property taxes and insurance. However, average land lease costs in Coastal region is \$3.60/kW-yr. Table 21-2 summarizes the average annual O&M expenses projected for an assumed 25-year project life.



Table 21-2 — Case 21 O&amp;M Cost Estimate

<b>Case 21</b>			
<b>EIA – Non-Fuel O&amp;M Costs – 2019 \$s</b>			
Onshore Wind – Small Plant Footprint: Coastal Region			
<b>Fixed O&amp;M – Plant (\$/kW-year) (Note 1)</b>			
WTG Scheduled Maintenance	\$/year		765,000
WTG Unscheduled Maintenance	\$/year		723,000
Balance of Plant Maintenance	\$/year		269,000
Subtotal Fixed O&M	\$/year		1,757,000
\$/kW-year	\$/kW-year		<b>35.14 \$/kW-year</b>
<b>Variable O&amp;M (\$/MWh) (Note 2)</b>			
	\$/MWh		<b>0.00 \$/MWh</b>
<b>O&amp;M Cost Notes</b>			
1. Fixed O&M costs include labor, materials and contracted services, and G&A costs.			
2. O&M Costs estimates reflect Full Service Agreement and exclude site specific owner's costs such as land lease, royalties, property taxes and insurance. Average land lease costs in Coastal region is \$3.60/kW-year.			
3. Average FSA term considered: 25 years			

## 21.4 ENVIRONMENTAL & EMISSIONS INFORMATION

Wind power projects do not produce regulated environmental air emissions. While other environmental compliance requirements may apply, only air emissions were considered for this report. Therefore, the emissions of NO<sub>x</sub>, SO<sub>2</sub>, and CO<sub>2</sub> are 0.00 lb/MMBtu.



## **CASE 22. OFFSHORE WIND, 400 MW**

### **22.1 CASE DESCRIPTION**

This case is an offshore wind project with a total 400-MW project capacity. The case configuration assumes wind turbines rated at 10 MW each, located 30 miles offshore in waters with a depth of 100 feet, and assumes a five-mile onshore cable run.

#### **22.1.1 Mechanical Equipment & Systems**

The offshore wind project is based on a total project capacity of 400 MW. Parameters that affect project cost and performance include project size, turbine nameplate capacity, water depth, and distance to shore. The case configuration assumes wind turbines rated at 10 MW each. They are located 30 miles offshore in waters with a 100-foot depth. An onshore cable run of five miles is also assumed.

For the purposes of this study, it has been assumed that wind turbines installed employ fixed-type foundation structures; monopile substructures were taken into consideration. Generally, these are installed in relatively shallow waters, not exceeding 150 feet, consistent with our assumption. Water depth and distance to shore has a significant impact on the cost of fixed foundation structure due to the expenses related to cable lengths and installation costs.

Wind turbine generators convert kinetic wind energy into electrical power. The most ubiquitous type of wind turbine used for electric power generation are those of the horizontal-axis three-bladed design. Lift is generated when wind flows around the turbine blades, resulting in rotation. The blades are connected to a central hub and drivetrain that turns a generator located inside of the nacelle, which is the housing positioned atop the wind turbine tower.

#### **22.1.2 Electrical & Control Systems**

Each wind turbine consists of a doubly-fed induction generator with high-speed electrical slip rings that produces electricity from the rotational energy of wind. The converter converts DC to AC. The power collection system collects energy from all the wind turbines and increases the voltage to 33–66 kV through a dedicated transformer at the WTG. Array cables, which are buried in the sea floor, transmit electricity to the offshore substation where the voltage is increased to 138 kV. It is then transmitted to an onshore substation via export cables. The power from this substation is supplied for interconnection with the transmission system.





A SCADA system is responsible for communications between the wind turbines and substation. The SCADA system allows the operations staff to remotely control and monitor each wind turbine and the wind project as a whole.

### 22.1.3 Offsite Requirements

Since wind is a clean source of energy, scope of offsite works is limited to construction of offshore-to-shore submarine cables, port infrastructures, installation vessels (construction and cable laying) and electrical interconnection to the transmission system.

## 22.2 CAPITAL COST ESTIMATE

The base cost estimate for this technology case totals \$4375/kW. Table 22-1 summarizes the cost components for this case.

Capital cost estimates were broken down into the following categories:

- **Civil/Structural Costs:** These costs include the port staging, WTG, and offshore substation foundations.
- **Mechanical Costs:** These costs include the purchase price for the WTGs from the OEM. This price includes the cost of the WTG equipment (blades, hub, drivetrain, generator, tower, and electronics), support vessels, transportation and delivery to port, and erection on site.
- **Electrical Costs:** These cost include interconnection, offshore and onshore transmission that includes inter array cabling, export cabling, and substations.
- **Project Indirect Costs:** These costs include construction management, engineering, and G&A costs.
- **EPC Fee:** The EPC fee is a markup charged by the construction contractor.
- **Project Contingency Costs:** Contingency is an allowance considered to cover the cost of undefined or uncertain scope of work, including EPC change orders or costs associated with schedule delays.
- **Owner Costs:** These costs include Project development costs that cover project feasibility analyses, wind resource assessments, offshore geotechnical and environmental loading studies, obtaining offshore leases, transmission access, and permitting. However, the estimates exclude project financing costs.



Table 22-1 — Case 22 Capital Cost Estimate

Case 22 EIA – Capital Cost Estimates – 2019 \$\$		
Configuration		<b>Fixed-bottom Offshore Wind: Monopile Foundations 400 MW   10 MW WTG</b>
Offshore Cable Length (mi)		30
Onshore Cable Length (mi)		5
Water Depth (ft)		100
<b>Units</b>		
<b>Plant Characteristics</b>		
Net Plant Capacity	MW	400
<b>Capital Cost Assumptions</b>		
EPC Contracting Fee	% of Direct & Indirect Costs	10%
Project Contingency	% of Project Costs	10%
Owner's Services	% of Project Costs	5%
<b>Typical Project Timelines</b>		
Development, Permitting, Engineering	months	24
Plant Construction Time	months	12
Total Lead Time Before COD	months	36
Operating Life	years	25
<b>Cost Components (Note 1)</b>		<b>Total</b>
<i>Civil/Structural/Architectural Subtotal</i>	\$	240,648,000
WTG Procurement and Supply	\$	653,008,000
WTG Assembly/Installation	\$	125,792,000
<i>Mechanical Subtotal</i>	\$	778,800,000
Interconnection	\$	60,995,000
Offshore Transmission & eBOP	\$	213,947,000
Onshore Transmission	\$	60,172,000
<i>Electrical Subtotal</i>	\$	335,114,000
Project Indirects	\$	74,800,000
EPC Total Before Fee	\$	1,429,362,000
EPC Fee	\$	85,762,000
<b>EPC Subtotal</b>	\$	1,515,124,000
<b>Owner's Cost Subtotal (Note 2)</b>	\$	75,756,200
<b>Project Contingency</b>	\$	159,088,000
<b>Total Capital Cost</b>	\$	1,749,968,200
		<b>\$/kW net 4,375</b>
<b>Capital Cost Notes</b>		
1. Costs based on EPC contracting approach. Direct costs include equipment, material, and labor to construct the civil/structural, mechanical, and electrical/I&C components of the facility. Indirect costs include distributable material and labor costs, cranes, scaffolding, engineering, construction management, startup and commissioning, and contractor overhead. EPC fees are applied to the sum of direct and indirect costs.		
2. Owner's costs include project development, studies, permitting, legal, owner's project management, owner's engineering, and owner's startup and commissioning costs. Other owner's costs include electrical interconnection costs.		

## 22.3 O&M COST ESTIMATE

Operating expenditures cover all maintenance expenses during operations, including management, labor, equipment and vessel rentals, parts, and consumables for both scheduled and unscheduled maintenance of the WTGs and BOP systems, as well as operations monitoring.



Table 22-2 — Case 22 O&amp;M Cost Estimate

Case 22 EIA – Non-Fuel O&M Costs – 2019 \$s		
Fixed-bottom Offshore Wind: Monopile Foundations		
Fixed O&M – Plant		
Subtotal Fixed O&M	\$/kW-year	110.00 \$/kW-year
Variable O&M	\$/MWh	0.00 \$/MWh

## 22.4 ENVIRONMENTAL & EMISSIONS INFORMATION

Wind power projects do not produce regulated environmental air emissions. While other environmental compliance requirements may apply, only air emissions were considered for this report. Therefore, the emissions of NO<sub>x</sub>, SO<sub>2</sub>, and CO<sub>2</sub> are 0.00 lb/MMBtu.



## **CASE 23. CONCENTRATING SOLAR PLANT, 100 MW, 8-HR STORAGE**

### **23.1 CASE DESCRIPTION**

This case is a concentrating solar thermal power plant (CSP) with eight hours of thermal storage. This type of plant is typically referred to as a “solar power tower” due to the central receiver tower, which is surrounded by a field of reflectors. The solar power tower uses a field of thousands of solar reflectors, called heliostats, to direct solar radiation energy to a central receiver, which is located at the top of the tower. The heliostats can rotate and pitch to direct the sunlight toward the receiver as the sun passes across the horizon.

The plant for this case is rated for 115 MW gross power, and an auxiliary load of approximately 15 MW is expected. Power is generated at 15.5 kV and 60 Hz. It is stepped up to 230 kV for transmission.

Figure 23-1 shows a diagram of the system assumed for this case. The plant is equipped with two molten salt tanks: one hot tank and one cold tank. Molten salt pumps move molten salt from the cold salt tank to the heat exchanger in the receiver where it absorbs energy from the solar radiation concentrated on the surface of the receiver. The hot molten salt flows down the tower to the hot molten salt tank. A molten salt pump from the power block moves molten salt from the hot salt tank through a steam generating heat exchanger to the cold salt tank. Superheated steam is generated in the heat exchanger, which is used to drive a steam turbine to turn a generator. The steam is condensed in an ACC. The plant is equipped with water treatment facilities to support the steam cycle. The plant control system operates both the power block and the solar field. As mentioned, the solar field may consist of thousands of individual heliostat reflectors. Some solar power tower projects include more than 10,000 heliostats. Recent advances in control technology have eliminated the need for control and power cabling to each heliostat. Instead, each heliostat is equipped with a photovoltaic (PV) solar panel and BESS to power the heliostat movement. Each heliostat has a control unit that communicates with a central controller wirelessly.

Figure 23-1 — Concentrating Solar Power Tower System Diagram

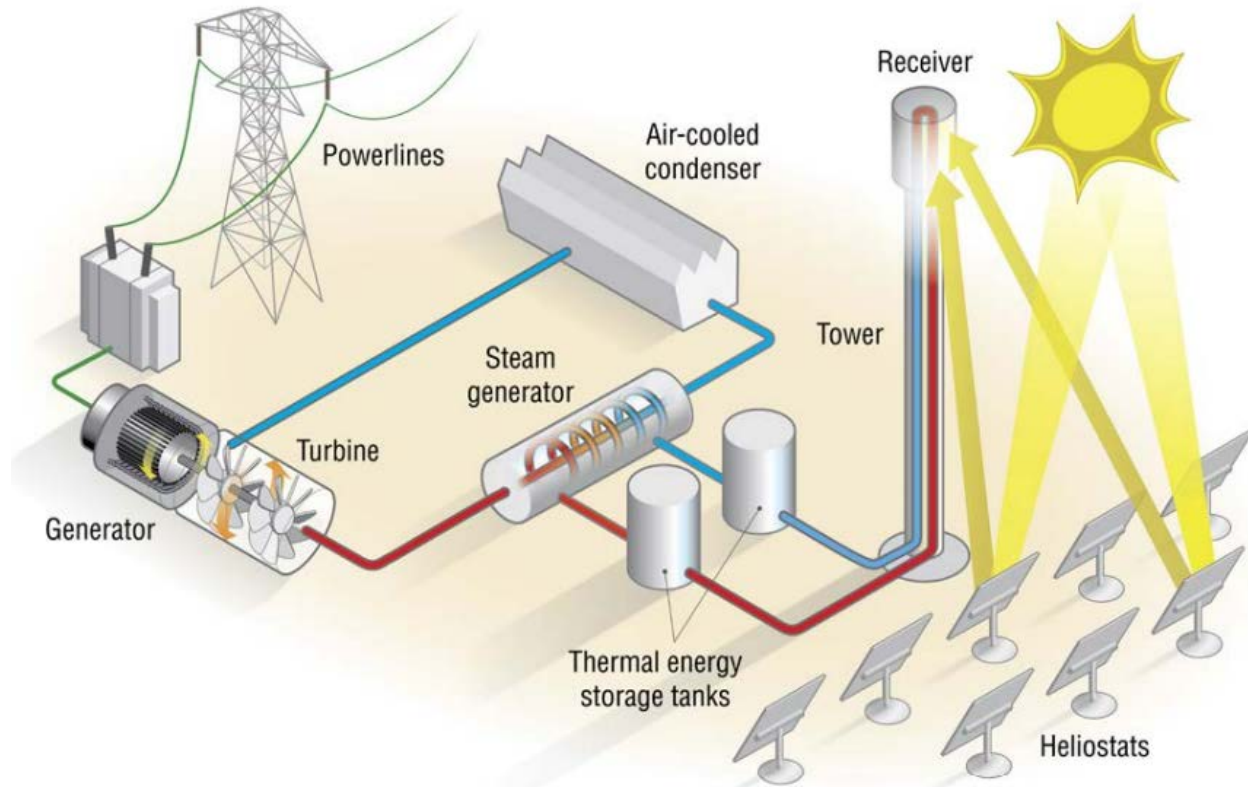

Source: U.S. Department of Energy, 2014: *The Year of Concentrating Solar Power*, May 2014. PDF.

Retrieved from Energy.gov, <https://www.energy.gov/sites/prod/files/2014/10/f18/CSP-report-final-web.pdf> (accessed June 13, 2019)

The thermal storage system is based on the amount of “hot” molten salt that is stored in the hot salt tank when the solar resource is no longer available after the sun goes down. The duration of storage is contingent on the amount of hot molten salt and its temperature that can be collected in a “solar day,” which depends on the solar resource available during that time.

Figure 23-2 shows an aerial view of a concentrating solar power tower plant. The central receiver can be seen on the top of a tower surrounded by thousands of heliostats. The ACC and hot and cold molten salt tanks are clearly shown. Buildings that house the control room, work shop, and spare parts warehouse are also shown.

**Figure 23-2 — Aerial View of Concentrating Solar Power Tower Project**

Crescent Dunes

**Source:** Loan Programs Office – U.S. Department of Energy, *DOE-LPO\_Project-Photos\_CSP\_Crescent-Dunes\_02*, ND. Digital Image. Retrieved from Energy.gov, <https://www.energy.gov/lpo/crescent-dunes> (accessed June 5, 2019)

Figure 23-3 shows the direct normal solar irradiance across the United States. The solar irradiance is used to determine the best location to capture solar energy.

Figure 23-3 — United States Solar Resource

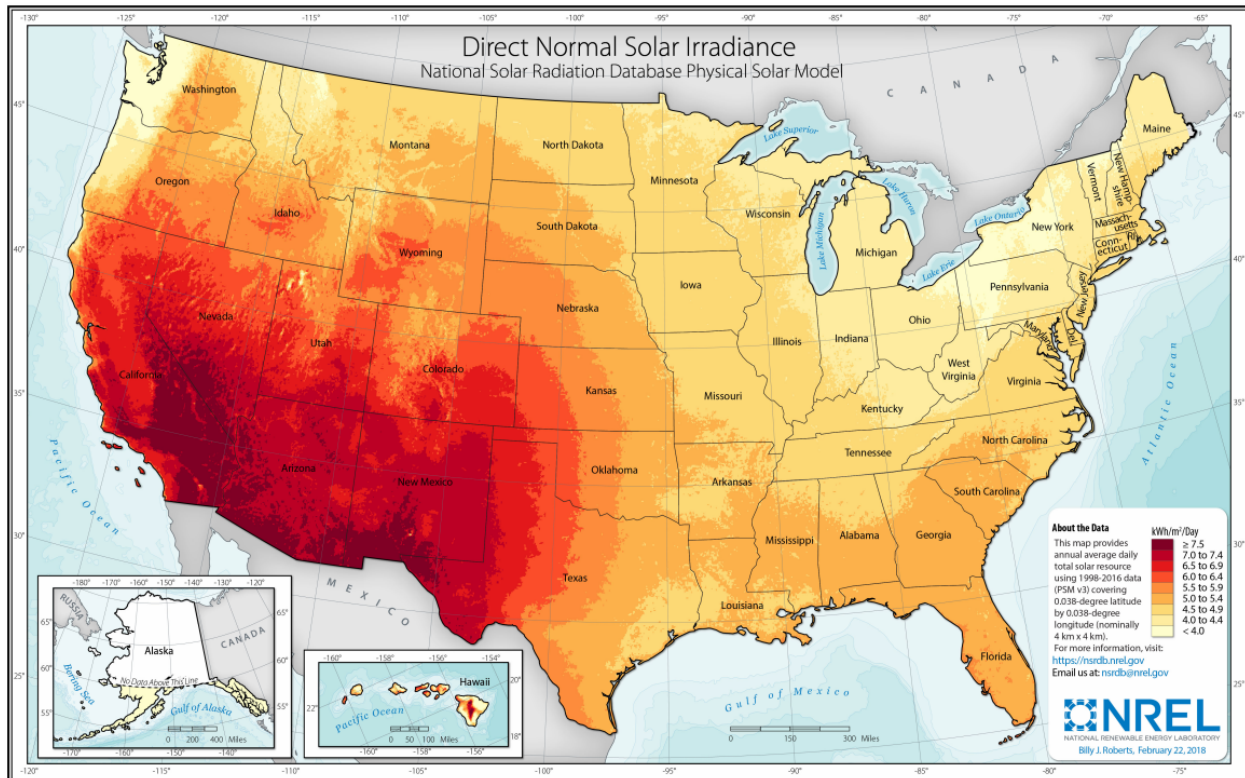

Source: U.S. Department of Energy, National Renewable Energy Laboratory, *Direct Normal Solar Irradiance*, ND. Retrieved from NREL.gov, [https://www.nrel.gov/gis/images/solar/solar\\_ghi\\_2018\\_usa\\_scale\\_01.jpg](https://www.nrel.gov/gis/images/solar/solar_ghi_2018_usa_scale_01.jpg) (accessed June 5, 2019).

### 23.1.1 Offsite Requirements

The cost estimate assumes an allowance for a one-mile transmission line. The estimates include the cost of onsite roads and a connection to an existing nearby highway. The estimate includes the cost of water supply infrastructure onsite; however, potable water and sewer tie-in are nearby.

## 23.2 CAPITAL COST ESTIMATE

The base cost estimate for this technology case totals \$7221/kW. Table 23-1 summarizes the cost components for this case. The capital cost is based on the latest cost information for mechanical and electrical components and considerations for implementing the latest available technology.

The cost estimate includes the cost for land, site clearing, civil works, drainage, roads on the plant site, and water supply infrastructure. The complete heliostat field cost includes the reflector, foundation pedestal, supports, and power and controls for each unit. The receiver tower is based on a concrete structure with an internal space for an elevator, molten salt piping, and related equipment. The molten



salt circulation system includes the molten salt pumps, piping, heat tracing, insulation, and related controls equipment. The costs consider the construction of the hot and cold molten salt tanks, their foundations, insulation, heat tracing, the molten salt itself, and related equipment. The steam cycle equipment (i.e., the steam generating superheater, ACC, water treatment system, piping, valves, foundation, instrumentation and controls, and all related equipment) are included. All electrical BOP, fire protection equipment, and other equipment and materials needed to complete construction are included in the cost estimate. All labor and equipment needed for construction is included with the cost estimate.

In the past few years, concentrating solar power technology has been implemented in the Middle East more frequently than the United States. Therefore, much of the publicly available cost information indicates a \$/installed kW significantly lower than the estimate in this report, which is for a project constructed in the United States. The installed project cost for an identical project in the Middle East (e.g., United Arab Emirates) can be expected to be lower by a significant amount. The lower costs are a result of several factors, including labor cost, which can be nearly half the cost as in the United States<sup>3</sup>; government assistance with financial costs (in the forms of favorable loan programs, low taxes, and other incentives); low profit margins; and aggressive contracting.

The capital cost estimate is based on an EPC contracting approach.

Typical project related costs are included, such as Owner's services, project development costs, studies, permitting, legal, project management, owner's engineering, and start-up and commissioning.

**Table 23-1 — Case 23 Capital Cost Estimate**

<b>Case 23</b>		
<b>EIA – Capital Cost Estimates – 2019 \$s</b>		
Configuration	Concentrating Solar Power Tower with Molten Salt Thermal Storage	
	Units	
<b>Plant Characteristics</b>		
Gross Power Rating	MW	115
Net Power Rating	MW	100
Thermal Storage	hr	8
<b>Capital Cost Assumptions</b>		
EPC Contracting Fee	% of Project Costs	10%
Project Contingency	% of Project Costs	10%
Owner's Services	% of Project Costs	7%
Estimated Land Requirement	acres	2,000
Estimated Land Cost	\$/acre	10,000

<sup>3</sup> <https://arstechnica.com/science/2018/10/are-super-cheap-solar-fields-in-the-middle-east-just-loss-leaders/>





<b>Case 23</b>			
<b>EIA – Capital Cost Estimates – 2019 \$s</b>			
Configuration	Concentrating Solar Power Tower with Molten Salt Thermal Storage		
Units			
<i>Electric Interconnection Costs</i>			
Transmission Line Cost	\$/mile		1,200,000
Miles	miles		1.00
<i>Typical Project Timelines</i>			
Development, Permitting, Engineering	months		15
Plant Construction Time	months		30
Total Lead Time Before COD	months		33
Operating Life	years		30
<b>Cost Components (Note 1)</b>			<b>Total</b>
<b>Direct Costs</b>			
Site Preparation	\$		18,474,000
Heliostat Field	\$		157,437,000
Tower	\$		24,816,000
Receiver	\$		74,081,000
Thermal Energy Storage System (TES)	\$		65,276,000
Balance of Plant – Steam System	\$		11,310,000
Balance of Plant – Electrical, Instrumentation and Controls	\$		9,186,000
Balance of Plant – Foundations & Support Structures	\$		15,917,000
Power Block (Steam Turbine, steam cycle, related systems)	\$		122,077,000
<i>Direct Costs Subtotal</i>	\$		498,574,000
Project Indirect	\$		37,135,000
EPC Total Before Fee	\$		535,709,000
EPC Fee	\$		53,571,000
<b>EPC Subtotal</b>	\$		<b>589,280,000</b>
<b>Owner's Cost Components (Note 2)</b>			
Owner's Services	\$		46,000,000
Land	\$		20,000,000
Electrical Interconnection	\$		1,200,000
<b>Owner's Cost Subtotal</b>	\$		<b>67,200,000</b>
<b>Project Contingency</b>	\$		<b>65,648,000</b>
<b>Total Capital Cost</b>	\$		<b>722,128,000</b>
<b>\$/kW net</b>			<b>7,221</b>
<b>Capital Cost Notes</b>			
<p>1. Costs based on EPC contracting approach. Direct costs include equipment, material, and labor to construct the civil/structural, mechanical, and electrical/I&amp;C components of the facility. Indirect costs include distributable material and labor costs, cranes, scaffolding, engineering, construction management, startup and commissioning, and contractor overhead. EPC fees are applied to the sum of direct and indirect costs.</p> <p>2. Owner's costs include project development, studies, permitting, legal, owner's project management, owner's engineering, and owner's startup and commissioning costs. Other owner's costs include electrical interconnection costs, gas interconnection costs (if applicable), and land acquisition costs.</p>			

### 23.3 O&M COST ESTIMATE

The O&M cost estimate incorporates the annual cost of the onsite O&M staff as well as contracted services for grounds keeping, mirror washing, water treatment, and computer maintenance. The O&M cost also incorporates the estimated annual water requirements, which will be purchased. The need for various consumables and replacement parts are also considered. Since the annual cost of consumables



for the plant can be estimated, the entire O&M cost is captured as a fixed amount. The variable cost is considered to be \$0.00/MWh.

**Table 23-2 — Case 23 O&M Cost Estimate**

<b>Case 23</b>		
<b>EIA – Non-Fuel O&amp;M Costs – 2019 \$s</b>		
Concentrating Solar Power Tower		
<b>Fixed O&amp;M – Plant (Note 1)</b>		
Subtotal Fixed O&M	\$/kW-year	<b>85.39 \$/kW-year</b>
<b>Variable O&amp;M (Note 2)</b>	\$/MWh	<b>0.00 \$/MWh</b>
<b>O&amp;M Cost Notes</b>		
1. Fixed O&M costs include labor, materials, utilities, and contracted services, and G&A costs. O&M Costs exclude property taxes and insurance.		
2. All costs tied to energy produced are covered in fixed cost.		

## 23.4 ENVIRONMENTAL & EMISSIONS INFORMATION

Concentrating solar power plants do not produce regulated environmental emissions. While other environmental compliance requirements may apply, only air emissions were considered for this report. Therefore, the emissions of NO<sub>x</sub>, SO<sub>2</sub>, and CO<sub>2</sub> are 0.00 lb/MMBtu.

## CASE 24. SOLAR PHOTOVOLTAIC, 150 MW<sub>AC</sub>

### 24.1 CASE DESCRIPTION

This case is a nominal 150-MW<sub>AC</sub> solar photovoltaic (PV) facility with single-axis tracking. With continued advances in technical efficiency and lower module price, solar PV cost has decreased significantly in the past decade. This case uses 195 MW<sub>DC</sub> of 1,500-V monocrystalline PERC modules with independent row trackers that are placed in a north-south orientation with east-west tracking. The case also uses 150 MW<sub>AC</sub> of central inverters, resulting in a DC/AC ratio of 1.3. The simplicity of solar PV projects is that there is no fuel or waste and limited moving parts; however, single-axis tracking systems require considerable land commitments due to a low ground coverage ratio intended to limit self-shading and create room for tracking rotation. Many tracking companies offer advanced backtracking software that help to optimize yield and ground coverage ratio, though this was not considered in this estimate.

Figure 24-1 — Solar Photovoltaic Project



Foothills Solar Project using single-axis tracking in Loveland, Colorado.

**Source:** American Public Power Association, *gray solar panel lot*, 2017. Digital Image.  
Retrieved from: Unsplash.com, <https://unsplash.com/photos/dCx2xFuPWks> (accessed June 12, 2019).

#### 24.1.1 Mechanical Equipment & Systems

PV refers to the conversion of light into electricity. Solar PV modules convert incident solar radiation into a potential difference within individual solar cells that produces DC electricity. The solar PV facility

assumed for this study is comprised of 487,500 individual 400-watt, 1500-V monocrystalline solar modules with PERC architecture for increased efficiency. These modules are connected in series to each other in strings of 30 modules per string. The strings connect to each other in parallel to form large solar arrays, which make up the bulk of the facility. Arrays are often grouped together into distinct blocks throughout the plant with each block having a single designated inverter pad. Mechanical components of these arrays include the racking and solar tracking equipment. This estimate assumes the racking uses a driven pile foundation; however, depending on the site's geotechnical characteristics, ground screws and concrete foundations can also be used.

The tracking system's exact mechanics depend on the manufacturer. This system, and nearly all single-axis tracking systems currently being manufactured, use a north-south oriented tracking axis that is horizontally parallel with respect to the ground. This orientation allows the panels to track the sun as it crosses the sky east to west. One variation in tracking mechanics that can impact the overall price is linked versus unlinked row tracking. Linked row tracking connects multiple rows to a single tracker mechanism, thereby requiring them all to rotate at the same angle throughout the day. Unlinked row tracking allows individual rows to track the sun at different angles but require a solar tracker mechanism on each row. This case assumes an unlinked single-axis tracker technology.

**Figure 24-2 — Single-Axis Tracking**

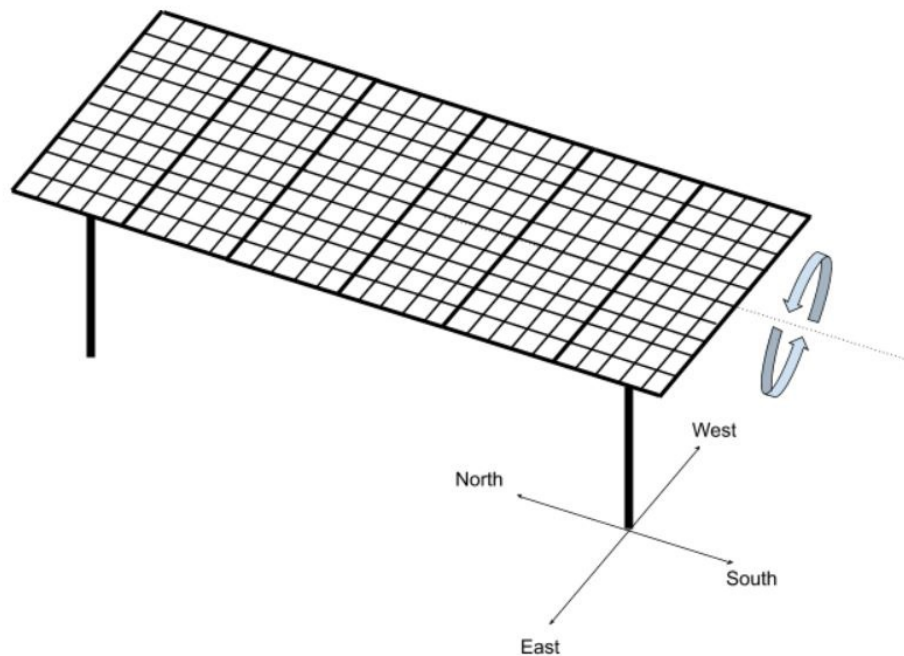



### 24.1.2 Electrical & Control Systems

Each block within a PV is made up of identical components and functionality. Electrical components include:

- DC and AC wiring
- Combiner boxes
- Inverters
- Step-up transformers
- Control system
- Switchyard with electrical interconnection to the grid

As previously explained, modules are combined in series to form series strings. These strings are combined in parallel to form solar arrays. Arrays are then connected via combiner boxes to combine the current from each string of each array before feeding the DC power into an inverter. The number of arrays combined into each combiner box is dependent on the site layout, the current of each string, and the size of the combiner box. This estimate assumes one combiner box for every thirty strings. After DC cables from the combiner boxes are fed into the inverter, the inverter then converts the DC electricity from the combiner boxes into AC electricity. Inverters currently used in new projects are typically rated between 1,500 kW and 4000 kW. There are also two types of solar inverters: central and string. This system uses two 2500-kW central inverters with one 5.05-MW medium voltage transformer within each PV block.

A solar facility's nominal capacity is typically defined by the net AC capacity of the inverters across all blocks. In general, there will always be more installed DC capacity from the modules than AC capacity from the inverters. The ratio of DC to AC capacity (DC/AC ratio) is typically between 1.2 and 1.4; however, some projects increase the DC/AC ratio with the intention of harnessing the DC power that is clipped by the inverter's maximum capacity into battery storage energy. On the other side of the spectrum, some projects will decrease the DC/AC ratio to allow for additional reactive compensation. This estimate assumes a DC/AC ratio of 1.3.

### 24.1.3 Offsite Requirements

Solar PV facilities require no fuel and produce no waste. The offsite requirements are limited to an interconnection between the PV facility and the transmission system as well as water for the purpose of cleaning the solar modules. Additionally, cleaning is regionally dependent. In regions with significant



rainfall and limited dust accumulation, cleaning is often unnecessary because it occurs naturally. In dust heavy and dry regions (which often have higher solar irradiance), cleaning occurs proportionally to the dust accumulation from once or twice a year up to bi-monthly and typically uses offsite water that is brought in on trucks. This analysis assumes two cleanings per year.

## 24.2 CAPITAL COST ESTIMATE

The base cost estimate for this technology case totals \$1313/kW. Table 24-1 summarizes the cost components for this case. Solar prices have been dropping due to reductions in equipment costs as well as the required construction labor. As solar modeling software advances, projects are able to optimize layouts and ground coverage for lowest levelized cost of energy, thereby allowing for reduced civil expenditures on a per kilowatt basis. Solar modules that are arriving on the market have a net potential of 1500 V rather than the previous standard of 1000 V. This increased net potential allows for lower wiring losses, which increases the net energy yield and lower wiring material costs to reduce the capital cost. Additionally, strides have been made to make modules more efficient to increase their power rating and lighter in weight to allow for reduced transportation and installation cost. Electrical components have been dropping in price, especially the inverters. As solar development advances and matures, EPC contractors and developers have also been bearing less contingency and overhead, further reducing a solar project's overall price.

**Table 24-1 — Case 24 Capital Cost Estimate**

Case 24 EIA – Capital Cost Estimates – 2019 \$s		
Configuration	Solar PV w/ Single Axis Tracking	
DC / AC Ratio	150 MW <sub>AC</sub>	
Module Type	1.3	
	Crystalline	
<b>Units</b>		
<b>Plant Characteristics</b>		
Net Plant Capacity	MW <sub>AC</sub>	150
<b>Capital Cost Assumptions</b>		
EPC Contracting Fee	% of Direct & Indirect Costs	5%
Project Contingency	% of Project Costs	5%
Owner's Services	% of Project Costs	4%
Estimated Land Requirement (acres) (Note 1)	\$	400
<b>Typical Project Timelines</b>		
Development, Permitting, Engineering	months	12
Plant Construction Time	months	6
Total Lead Time Before COD	months	18
Operating Life	years	30



<b>Case 24</b>			
<b>EIA – Capital Cost Estimates – 2019 \$\$</b>			
Configuration	<b>Solar PV w/ Single Axis Tracking</b>		
DC / AC Ratio	150 MW <sub>AC</sub>		
Module Type	1.3		
	Crystalline		
		Units	
Cost Components (Note 2)		Breakout	Total
<i>Civil/Structural/Architectural Subtotal</i>	\$		7,935,000
Mechanical – Racking, Tracking, & Module Installation	\$	36,391,000	
<i>Mechanical Subtotal</i>	\$		36,391,000
Electrical – Inverters	\$	9,430,000	
Electrical – BOP and Miscellaneous	\$	28,328,000	
Electrical – Transformer, Substation, & MV System	\$	17,756,000	
Electrical – Backup Power, Control, & Data Acquisition	\$	3,733,000	
<i>Electrical Subtotal</i>	\$		59,247,000
Project Indirects	\$		2,114,000
EPC Total Before Fee	\$		105,687,000
EPC Fee	\$		5,284,000
<i>EPC Subtotal</i>	\$		110,971,000
<b>Owner's Cost Components (Note 3)</b>			
Owner's Services	\$		4,439,000
Modules (Note 3)	\$		72,150,000
<i>Owner's Costs Subtotal</i>	\$		76,589,000
<i>Project Contingency</i>	\$		9,378,000
<b>Total Capital Cost</b>	<b>\$</b>		<b>196,938,000</b>
		<b>\$/kW net</b>	<b>1,313</b>
<b>Capital Cost Notes</b>			
<p>1. Land is typically leased and not considered in CAPEX. Costs based on EPC contracting approach. Direct costs include equipment, material, and labor to construct the civil/structural, mechanical, and electrical/I&amp;C components of the facility. Indirect costs include distributable material and labor costs, cranes, scaffolding, engineering, construction management, startup and commissioning, and contractor overhead. EPC fees are applied to the sum of direct and indirect costs.</p> <p>2. Owner's costs include project development, studies, permitting, legal, owner's project management, owner's engineering, and owner's startup and commissioning costs. Other owner's costs include electrical interconnection costs.</p> <p>3. Modules purchased by Owner</p>			

### 24.3 O&M COST ESTIMATE

Operations and maintenance costs associated with 150-MW<sub>AC</sub>, single-axis tracking solar PV project have also been decreasing. There are five main factors to solar PV O&M: preventative maintenance, unscheduled maintenance, module cleaning, inverter maintenance reserve, and the land lease. As technological reliability increases and designs become more focused on decreasing O&M costs, preventative maintenance gets less costly and unscheduled maintenance occurs less frequently. Examples of O&M-focused designs are DC harnesses for optimal wiring configurations, wireless communication and control systems, and central inverter locations for ease of access. Cleaning is also typically less expensive for PV fields with trackers using independent rows because a single truck can clean two rows at a time instead of one. Additionally, inverter manufacturers have begun to offer extended warranties up to a 10-year period and at roughly the same cost as the assumed inverter reserve



amount. Decreasing inverter prices also allows for a smaller inverter reserve to be set aside. The final annual expense is the land lease. Solar PV projects typically rent, rather than purchase, the land for the project; therefore, it is an operating expense and not a capital cost.

**Table 24-2 — Case 24 O&M Cost Estimate**

<b>Case 24</b>		
<b>EIA – Non-Fuel O&amp;M Costs – 2019 \$s</b>		
Solar PV w/ Single Axis Tracking		
<b>Fixed O&amp;M – Plant (\$/year) (Note 1)</b>		
Preventative Maintenance	\$/year	1,104,000
Module Cleaning (Note 2)	\$/year	613,000
Unscheduled Maintenance	\$/year	96,000
Inverter Maintenance Reserve	\$/year	342,000
Land Lease (Note 3)	\$/year	<u>133,000</u>
Subtotal Fixed O&M	\$/year	2,288,000
\$/kW-year	\$/kW-year	<b>15.25 \$/kW-yr</b>
<b>Variable O&amp;M (\$/MWh)</b>	\$/MWh	<b>0.00 \$/MWh</b>
<b>O&amp;M Cost Notes</b>		
1. Fixed O&M costs include labor, materials and contracted services, and G&A costs. O&M Costs exclude property taxes and insurance.		
2. Assume two module cleanings per year.		
3. Solar PV projects typically rent land rather than purchase it, this is considered to be a representative annual expense but varies across projects.		

## 24.4 ENVIRONMENTAL & EMISSIONS INFORMATION

Solar PV does not produce regulated environmental air emissions. While other environmental compliance requirements may apply, only air emissions were considered for this report. Therefore, the emissions of NO<sub>x</sub>, SO<sub>2</sub>, and CO<sub>2</sub> are 0.00 lb/MMBtu.





## **CASE 25. SOLAR PHOTOVOLTAIC WITH BATTERY ENERGY STORAGE SYSTEM, 150 MW<sub>AC</sub>**

### **25.1 CASE DESCRIPTION**

This case is based on a nominal 150-MW<sub>AC</sub> solar PV plant with 200 MWh of lithium-ion battery storage. Solar PV has increasingly been coupled with battery storage in recent years due to price reductions in solar PV and lithium-ion batteries. The factors driving cost reductions of solar PV projects are shared with systems coupled with battery storage: Modeling technology optimizes design and reduces civil costs per kW, higher power modules, lower priced inverters, and lower risk. Batteries can be either AC- or DC-coupled to the solar array. DC-coupled systems connect the battery directly to the solar array via DC wiring. This estimate assumes an AC-coupled system; this configuration is more prevalent in recent projects. AC-coupled systems offer higher efficiency when used in power AC applications, but they also have slightly lower efficiencies when charging the battery. The most common application for AC-coupled system is peak shaving, or energy arbitrage, where there is a limit on the power allowed into the grid and the peak of the solar generation is stored in a battery to be sold during the highest demand peaks for optimal profit.

#### **25.1.1 Mechanical Equipment & Systems**

This case assumes a nominal 150-MW<sub>AC</sub> solar PV plant with 200 MWh of lithium-ion battery storage. Batteries are typically sized by their output in kWh and not by their capacity in MW, which is defined by the AC capacity of the battery's inverters. The 200-MWh battery system in this estimate is comprised of four hours of 50 MW output. The mechanical equipment for the solar portion is the same as a stand-alone solar PV facility: 400-watt solar modules, ground mounted racking with driven pile foundations, and independent single-axis tracking equipment. The mechanical equipment associated with the battery storage is the batteries themselves, the containers they are placed in, the fire suppression system, and the concrete foundations for the battery containers. This estimate assumes the use of 40 containers, each 40 feet in length and containing 5,000 kWh of battery storage. Smaller 20-foot containers are sometimes used depending on constraints with site availability and project size. Both the 20-foot and 40-foot containers are always installed with extra space inside to allow for annual installation of more batteries so that the entire container keeps a constant year-on-year net output despite battery degradation. There are more containers in a PV system with battery storage over a standalone BESS due to the increased project life of PV. The additional containers allow for more augmentation over the life of the PV project rather than the life of the battery storage.

### 25.1.2 Electrical & Control Systems

When incorporating AC-coupled battery storage into a solar PV site, there is no change in the electrical components of the solar array and solar inverters. The solar modules are connected in series with DC wiring into solar strings. The solar strings are connected in parallel to combiner boxes that output the current into the solar inverters. The output of the solar inverter then enters a switchgear that feeds the AC current into either the grid or the battery inverter. It is also important to note that battery storage inverters are different from solar inverters in that they are typically bi-direction inverters that can alternate between inverting AC to DC and inverting DC to AC. Battery storage inverters also allow the batteries to be charged by either the solar array or the grid. This facility uses 150 MW of solar inverters plus 50 MW of battery inverters. Battery inverters are significantly more expensive than solar inverters.

**Figure 25-1 — AC Coupled Solar PV and Battery Storage**

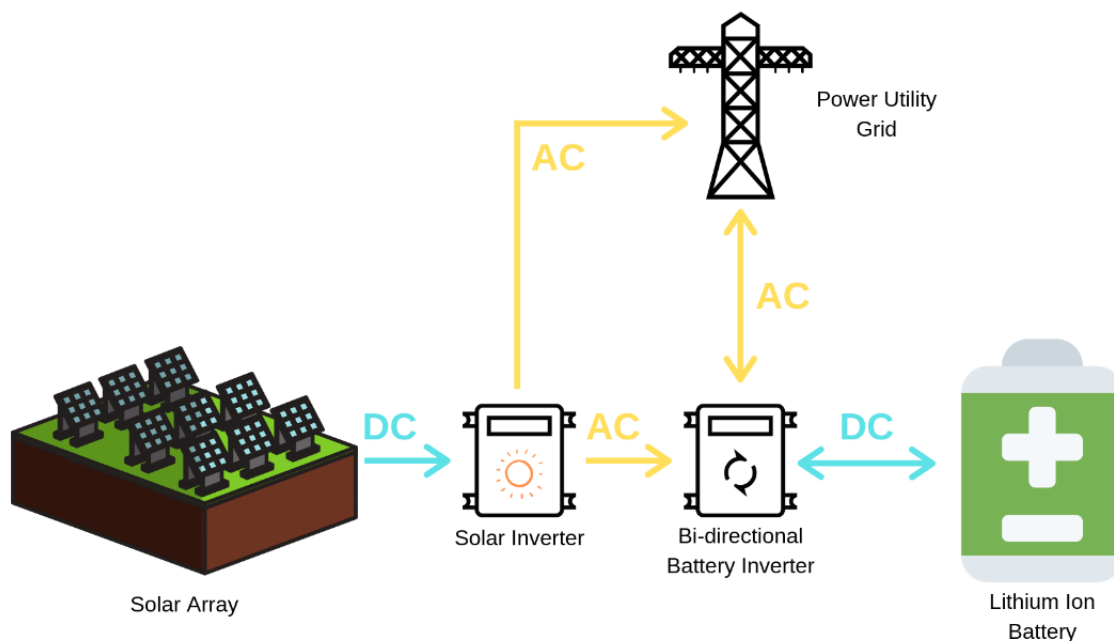

Adapted from Clean Energy Reviews,  
<https://www.cleanenergyreviews.info/blog/ac-coupling-vs-dc-coupling-solar-battery-storage> (accessed June 12, 2019).

Whether power is being used from the battery storage or the solar array, it passes through a switchyard that contains the circuit breaker, step-up transformer, and electrical interconnection with the grid.

### 25.1.3 Offsite Requirements

Solar PV and battery storage facilities require no fuel and produce no waste. The offsite requirements are limited to an interconnection between the facility and the transmission system as well as water for



the purpose of cleaning the solar modules. Cleaning is regionally dependent. In regions with significant rainfall and limited dust accumulation, cleaning is often unnecessary and occurs naturally. In dust heavy and dry regions, cleaning typically occurs once or twice a year and uses offsite water that is brought in on trucks. This analysis assumes two cleanings per year.

## 25.2 CAPITAL COST ESTIMATE

The base cost estimate for this technology case totals \$1755/kW. Table 25-1 summarizes the cost components for this case.

**Table 25-1 — Case 25 Capital Cost Estimate**

<b>Case 25</b>		
<b>EIA – Capital Cost Estimates – 2019 \$s</b>		
<b>Configuration</b>	<b>Solar PV w/ Single Axis Tracking + Battery Storage</b>	
<b>Battery Configuration</b>	AC Coupled	
<b>DC / AC Ratio</b>	1.3	
<b>Module Type</b>	Crystalline	
<b>Battery Type</b>	Lithium-ion	
<b>Units</b>		
<b>Plant Characteristics</b>		
Net Solar Capacity	MW_AC	150
Net Battery Capacity	MW_AC	50
<b>Capital Cost Assumptions</b>		
EPC Contracting Fee	% of Direct & Indirect Costs	5%
Project Contingency	% of Project Costs	5%
Owner's Services	% of Project Costs	4%
Estimated Land Requirement (acres) Note 1	\$	401
<b>Typical Project Timelines</b>		
Development, Permitting, Engineering	months	12
Plant Construction Time	months	6
Total Lead Time Before COD	months	18
Operating Life	years	30
<b>Cost Components (Note 2)</b>		<b>Breakout</b>
<b>Civil/Structural/Architectural Subtotal</b>		<b>Total</b>
Civil/Structural/Architectural Subtotal	\$	17,596,000
Mechanical – Racking, Tracking, & Module Installation	\$	36,391,000
<b>Mechanical Subtotal</b>		<b>\$</b>
<b>Electrical Subtotal</b>		<b>\$</b>
Electrical – Batteries	\$	40,037,000
Electrical – Inverters	\$	14,459,000
Electrical – BOP and Miscellaneous	\$	28,453,000
Electrical – Transformer, Substation, & MV System	\$	18,647,000
Electrical – Backup Power, Control, & Data Acquisition	\$	3,755,000
<b>Electrical Subtotal</b>		<b>\$</b>
Project Indirects	\$	4,202,000
EPC Total Before Fee	\$	163,539,000
EPC Fee	\$	8,177,000
<b>EPC Subtotal</b>		<b>\$</b>
<b>Owner's Cost Components (Note 3)</b>		
Owner's Services	\$	6,869,000



<b>Case 25</b>		
<b>EIA – Capital Cost Estimates – 2019 \$s</b>		
<b>Configuration</b>	<b>Solar PV w/ Single Axis Tracking + Battery Storage</b>	
<b>Battery Configuration</b>	AC Coupled	
<b>DC / AC Ratio</b>	1.3	
<b>Module Type</b>	Crystalline	
<b>Battery Type</b>	Lithium-ion	
	<b>Units</b>	
Modules (Note 3)	\$	72,150,000
<b>Owner's Cost Subtotal</b>	<b>\$</b>	<b>79,019,000</b>
<b>Project Contingency</b>	<b>\$</b>	<b>12,537,000</b>
<b>Total Capital Cost</b>	<b>\$</b>	<b>263,272,000</b>
	<b>\$/kW net</b>	<b>1,755</b>
<b>Capital Cost Notes</b>		
<p>1. Land is typically leased and not considered in CAPEX. Costs based on EPC contracting approach. Direct costs include equipment, material, and labor to construct the civil/structural, mechanical, and electrical/I&amp;C components of the facility. Indirect costs include distributable material and labor costs, cranes, scaffolding, engineering, construction management, startup and commissioning, and contractor overhead. EPC fees are applied to the sum of direct and indirect costs.</p> <p>2. Owner's costs include project development, studies, permitting, legal, owner's project management, owner's engineering, and owner's startup and commissioning costs. Other owner's costs include electrical interconnection costs.</p> <p>3. Modules purchased directly by owner.</p>		

### 25.3 O&M COST ESTIMATE

For this case, Sargent & Lundy grouped the O&M costs into the following categories: preventative maintenance, unscheduled maintenance, module cleaning, inverter maintenance reserve, battery maintenance reserve, and the land lease. Descriptions of all the factors except the battery maintenance reserve can be found in Section 24.3. The typical lifetime of a battery is 3000 cycles, which yields a lifetime of roughly 10 years (based on approximately one cycle per day). Battery systems typically account for degradation and a 10-year battery lifetime by leaving physical space within the BESS containers for additional batteries to be installed to augment the system each year. The battery reserve in this case is higher than standalone battery storage because it accounts for battery augmentation as well as additional battery replacements every 10 years to allow for a 30-year system life.



Table 25-2 — Case 25 O&amp;M Cost Estimate

<b>Case 25</b>		
<b>EIA – Non-Fuel O&amp;M Costs – 2019 \$s</b>		
Solar PV w/ Single Axis Tracking + Battery Storage		
<b>Fixed O&amp;M – Plant (Note 1)</b>		
Preventative Maintenance	\$/year	1,545,000
Module Cleaning (Note 2)	\$/year	613,000
Unscheduled Maintenance	\$/year	115,000
Inverter Maintenance Reserve	\$/year	455,000
Battery Maintenance Reserve	\$/year	1,963,000
Land Lease (Note 3)	\$/year	<u>134,000</u>
Subtotal Fixed O&M	\$/year	4,825,000
\$/kW-year	\$/kW-year	<b>32.17 \$/kW-year</b>
<b>Variable O&amp;M</b>	\$/MWh	<b>0.00 \$/MWh</b>
<b>O&amp;M Cost Notes</b>		
1. Fixed O&M costs include labor, materials and contracted services, and G&A costs. O&M Costs exclude property taxes and insurance.		
2. Assume two module cleanings per year.		
3. Solar PV projects typically rent land rather than purchase it, this is considered to be a representative annual expense but varies across projects.		

## 25.4 ENVIRONMENTAL & EMISSIONS INFORMATION

Neither solar PV nor battery storage produce regulated environmental air emissions. While other environmental compliance requirements may apply, only air emissions were considered for this report. Therefore, the emissions of NO<sub>x</sub>, SO<sub>2</sub>, and CO<sub>2</sub> are 0.00 lb/MMBtu.



---

## **Appendix A. Location-Based Adjustment Factors**

---

# Location-Based Adjustment Factors

## **Capital Cost Study** *Cost and Performance Estimates for New Utility-Scale Electric Power Generating Technologies*

**Prepared by**  
Sargent & Lundy



**Prepared for**  
U.S. Energy Information  
Administration



**FINAL**

Contract No. 89303019CEI00022  
Project No. 13651-005

Table 1 1 — Location Adjustment for Non-New Source Performance Standard Compliant Ultra-Supercritical Coal (NSPS for NOX, Sox, PM, Hg)

(2019 Dollars)

Case Configuration: 650 MW<sub>Net</sub>

State	City	Base Project Cost (\$/kW )	Location Variation	Delta Cost Difference (\$/kW)	Total Location Project Cost (\$/kW)
Alabama	Huntsville	3,676	0.97	(128)	3549
Arizona	Phoenix	3,676	1.05	199	3875
Arkansas	Little Rock	3,676	0.96	(133)	3543
California	Bakersfield	3,676	1.26	973	4649
California	Los Angeles	3,676	1.27	989	4665
California	Modesto (instead of Redding)	3,676	1.28	1,017	4694
California	Sacramento	3,676	1.29	1,076	4752
California	San Francisco	3,676	1.37	1,367	5043
Colorado	Denver	3,676	1.03	100	3776
Connecticut	Hartford	3,676	1.24	877	4554
Delaware	Dover	3,676	1.22	801	4477
District of Columbia	Washington	3,676	1.08	307	3983
Florida	Tallahassee	3,676	0.95	(194)	3483
Florida	Tampa	3,676	0.97	(127)	3549
Georgia	Atlanta	3,676	0.99	(46)	3630
Idaho	Boise	3,676	1.03	105	3781
Illinois	Chicago	3,676	1.28	1,018	4694
Illinois	Joliet	3,676	1.24	869	4545
Indiana	Indianapolis	3,676	1.02	74	3750
Iowa	Davenport	3,676	1.05	173	3850
Iowa	Waterloo	3,676	0.97	(97)	3579
Kansas	Wichita	3,676	0.98	(85)	3592
Kentucky	Louisville	3,676	1.01	26	3702
Louisiana	New Orleans	3,676	0.97	(104)	3572
Maine	Portland	3,676	1.03	114	3790
Maryland	Baltimore	3,676	1.02	86	3762
Massachusetts	Boston	3,676	1.29	1,050	4726
Michigan	Detroit	3,676	1.12	459	4135
Michigan	Grand Rapids	3,676	1.05	168	3844
Minnesota	Saint Paul	3,676	1.11	411	4087
Mississippi	Jackson	3,676	0.95	(186)	3490
Missouri	St. Louis	3,676	1.13	461	4137
Missouri	Kansas City	3,676	1.08	297	3974
Montana	Great Falls	3,676	0.97	(104)	3572
Nebraska	Omaha	3,676	0.98	(78)	3599
New Hampshire	Concord	3,676	1.14	510	4186
New Jersey	Newark	3,676	1.24	881	4557
New Mexico	Albuquerque	3,676	0.99	(47)	3629
New York	New York	3,676	1.57	2,109	5785
New York	Syracuse	3,676	1.13	487	4163
Nevada	Las Vegas	3,676	1.15	556	4233
North Carolina	Charlotte	3,676	0.96	(144)	3532
North Dakota	Bismarck	3,676	1.04	133	3810
Oklahoma	Oklahoma City	3,676	1.01	30	3707
Oklahoma	Tulsa	3,676	0.93	(261)	3415
Ohio	Cincinnati	3,676	0.93	(262)	3414
Oregon	Portland	3,676	1.16	584	4261
Pennsylvania	Philadelphia	3,676	1.30	1,092	4769
Pennsylvania	Wilkes-Barre	3,676	1.15	561	4238
Rhode Island	Providence	3,676	1.21	781	4457
South Carolina	Charleston	3,676	0.96	(159)	3518
South Carolina	Spartanburg (Asheville, NC)	3,676	0.97	(116)	3561
South Dakota	Rapid City	3,676	0.98	(73)	3603
Tennessee	Knoxville (Nashville)	3,676	0.97	(104)	3573
Texas	Houston	3,676	0.93	(260)	3416
Utah	Salt Lake City	3,676	0.98	(60)	3617
Vermont	Burlington	3,676	1.05	167	3843
Virginia	Alexandria	3,676	1.08	280	3956
Virginia	Lynchburg	3,676	1.02	70	3746
Washington	Seattle	3,676	1.14	505	4182
Washington	Spokane	3,676	1.06	210	3886
West Virginia	Charleston	3,676	1.04	162	3839
Wisconsin	Green Bay	3,676	1.06	209	3886
Wyoming	Cheyenne	3,676	0.99	(20)	3656



Table 1 2 — Location Adjustment for New Source Performance Standard Compliant Ultra-Supercritical Coal (with 30% CCS or Other Compliance Technology) (2019 Dollars)

Case Configuration: 650 MW<sub>Net</sub>

State	City	Base Project Cost (\$/kW )	Location Variation	Delta Cost Difference (\$/kW)	Total Location Project Cost (\$/kW)
Alabama	Huntsville	4,558	0.97	(155)	4,403
Arizona	Phoenix	4,558	1.05	250	4,808
Arkansas	Little Rock	4,558	0.97	(129)	4,429
California	Bakersfield	4,558	1.24	1,114	5,672
California	Los Angeles	4,558	1.25	1,132	5,690
California	Modesto (instead of Redding)	4,558	1.26	1,162	5,721
California	Sacramento	4,558	1.27	1,227	5,785
California	San Francisco	4,558	1.34	1,547	6,105
Colorado	Denver	4,558	1.03	139	4,697
Connecticut	Hartford	4,558	1.22	1,000	5,558
Delaware	Dover	4,558	1.20	905	5,463
District of Columbia	Washington	4,558	1.08	371	4,929
Florida	Tallahassee	4,558	0.95	(209)	4,349
Florida	Tampa	4,558	0.97	(135)	4,423
Georgia	Atlanta	4,558	0.99	(42)	4,516
Idaho	Boise	4,558	1.03	120	4,678
Illinois	Chicago	4,558	1.25	1,118	5,676
Illinois	Joliet	4,558	1.21	954	5,513
Indiana	Indianapolis	4,558	1.02	88	4,646
Iowa	Davenport	4,558	1.04	190	4,748
Iowa	Waterloo	4,558	0.98	(107)	4,451
Kansas	Wichita	4,558	0.98	(93)	4,465
Kentucky	Louisville	4,558	1.01	35	4,593
Louisiana	New Orleans	4,558	0.98	(101)	4,458
Maine	Portland	4,558	1.03	128	4,686
Maryland	Baltimore	4,558	1.02	96	4,654
Massachusetts	Boston	4,558	1.26	1,191	5,749
Michigan	Detroit	4,558	1.11	504	5,062
Michigan	Grand Rapids	4,558	1.04	184	4,742
Minnesota	Saint Paul	4,558	1.10	444	5,002
Mississippi	Jackson	4,558	0.96	(202)	4,356
Missouri	St. Louis	4,558	1.11	523	5,081
Missouri	Kansas City	4,558	1.07	327	4,885
Montana	Great Falls	4,558	0.97	(116)	4,442
Nebraska	Omaha	4,558	0.98	(85)	4,473
New Hampshire	Concord	4,558	1.13	603	5,162
New Jersey	Newark	4,558	1.21	970	5,528
New Mexico	Albuquerque	4,558	0.99	(37)	4,521
New York	New York	4,558	1.52	2,351	6,910
New York	Syracuse	4,558	1.12	567	5,125
Nevada	Las Vegas	4,558	1.14	623	5,182
North Carolina	Charlotte	4,558	0.97	(158)	4,400
North Dakota	Bismarck	4,558	1.03	139	4,697
Oklahoma	Oklahoma City	4,558	1.01	32	4,590
Oklahoma	Tulsa	4,558	0.94	(288)	4,270
Ohio	Cincinnati	4,558	0.94	(289)	4,269
Oregon	Portland	4,558	1.15	687	5,245
Pennsylvania	Philadelphia	4,558	1.27	1,234	5,793
Pennsylvania	Wilkes-Barre	4,558	1.14	649	5,208
Rhode Island	Providence	4,558	1.20	896	5,455
South Carolina	Charleston	4,558	0.97	(144)	4,414
South Carolina	Spartanburg (Asheville, NC)	4,558	0.97	(119)	4,439
South Dakota	Rapid City	4,558	0.98	(88)	4,470
Tennessee	Knoxville (Nashville)	4,558	0.98	(100)	4,458
Texas	Houston	4,558	0.94	(285)	4,273
Utah	Salt Lake City	4,558	0.99	(52)	4,506
Vermont	Burlington	4,558	1.05	210	4,768
Virginia	Alexandria	4,558	1.07	341	4,899
Virginia	Lynchburg	4,558	1.02	108	4,666
Washington	Seattle	4,558	1.12	569	5,127
Washington	Spokane	4,558	1.05	236	4,795
West Virginia	Charleston	4,558	1.04	178	4,736
Wisconsin	Green Bay	4,558	1.05	221	4,779
Wyoming	Cheyenne	4,558	0.99	(25)	4,533

**Table 1 3 — Location Adjustment for Ultra-Supercritical Coal (with 90% CCS)**  
**(2019 Dollars)**  
**Case Configuration: 650 MW<sub>Net</sub>**

State	City	Base Project Cost (\$/kW )	Location Variation	Delta Cost Difference (\$/kW)	Total Location Project Cost (\$/kW)
Alabama	Huntsville	5,876	0.98	(126)	5750
Arizona	Phoenix	5,876	1.04	232	6108
Arkansas	Little Rock	5,876	0.98	(99)	5777
California	Bakersfield	5,876	1.22	1,278	7153
California	Los Angeles	5,876	1.22	1,300	7176
California	Modesto (instead of Redding)	5,876	1.23	1,333	7209
California	Sacramento	5,876	1.24	1,408	7284
California	San Francisco	5,876	1.30	1,778	7654
Colorado	Denver	5,876	1.02	99	5974
Connecticut	Hartford	5,876	1.19	1,114	6990
Delaware	Dover	5,876	1.17	972	6848
District of Columbia	Washington	5,876	1.06	381	6257
Florida	Tallahassee	5,876	0.96	(235)	5640
Florida	Tampa	5,876	0.98	(143)	5733
Georgia	Atlanta	5,876	1.00	(21)	5855
Idaho	Boise	5,876	1.03	155	6031
Illinois	Chicago	5,876	1.22	1,310	7186
Illinois	Joliet	5,876	1.19	1,118	6994
Indiana	Indianapolis	5,876	1.02	126	6001
Iowa	Davenport	5,876	1.04	221	6097
Iowa	Waterloo	5,876	0.98	(125)	5751
Kansas	Wichita	5,876	0.98	(111)	5765
Kentucky	Louisville	5,876	1.01	64	5939
Louisiana	New Orleans	5,876	0.99	(74)	5802
Maine	Portland	5,876	1.03	157	6033
Maryland	Baltimore	5,876	1.02	118	5993
Massachusetts	Boston	5,876	1.23	1,341	7216
Michigan	Detroit	5,876	1.10	590	6466
Michigan	Grand Rapids	5,876	1.04	214	6090
Minnesota	Saint Paul	5,876	1.08	497	6372
Mississippi	Jackson	5,876	0.96	(230)	5645
Missouri	St. Louis	5,876	1.11	667	6543
Missouri	Kansas City	5,876	1.07	383	6259
Montana	Great Falls	5,876	0.98	(142)	5734
Nebraska	Omaha	5,876	0.98	(99)	5777
New Hampshire	Concord	5,876	1.12	682	6558
New Jersey	Newark	5,876	1.20	1,146	7022
New Mexico	Albuquerque	5,876	1.00	3	5879
New York	New York	5,876	1.46	2,675	8551
New York	Syracuse	5,876	1.10	602	6477
Nevada	Las Vegas	5,876	1.13	772	6648
North Carolina	Charlotte	5,876	0.97	(186)	5690
North Dakota	Bismarck	5,876	1.02	137	6013
Oklahoma	Oklahoma City	5,876	1.01	32	5908
Oklahoma	Tulsa	5,876	0.94	(341)	5535
Ohio	Cincinnati	5,876	0.94	(342)	5534
Oregon	Portland	5,876	1.13	782	6658
Pennsylvania	Philadelphia	5,876	1.24	1,382	7258
Pennsylvania	Wilkes-Barre	5,876	1.12	700	6576
Rhode Island	Providence	5,876	1.17	1,005	6881
South Carolina	Charleston	5,876	0.99	(72)	5804
South Carolina	Spartanburg (Asheville, NC)	5,876	0.98	(113)	5763
South Dakota	Rapid City	5,876	0.98	(128)	5748
Tennessee	Knoxville (Nashville)	5,876	0.99	(71)	5804
Texas	Houston	5,876	0.94	(331)	5545
Utah	Salt Lake City	5,876	1.00	(18)	5858
Vermont	Burlington	5,876	1.06	334	6209
Virginia	Alexandria	5,876	1.06	346	6222
Virginia	Lynchburg	5,876	1.01	71	5947
Washington	Seattle	5,876	1.12	713	6589
Washington	Spokane	5,876	1.05	298	6173
West Virginia	Charleston	5,876	1.04	206	6082
Wisconsin	Green Bay	5,876	1.04	229	6105
Wyoming	Cheyenne	5,876	0.99	(40)	5836

**Table 1 4 — Location Adjustment for Internal Combustion Engines (Natural Gas or Oil-fired Diesel)  
(2019 Dollars)**

**Case Configuration: 20 MW (4x 5.6 MW)**

State	City	Base Project Cost (\$/kW )	Location Variation	Delta Cost Difference (\$/kW)	Total Location Project Cost (\$/kW)
Alabama	Huntsville	1,810	0.97	(48)	1,762
Arizona	Phoenix	1,810	0.98	(32)	1,778
Arkansas	Little Rock	1,810	0.98	(32)	1,777
California	Bakersfield	1,810	1.16	292	2,102
California	Los Angeles	1,810	1.17	303	2,112
California	Modesto (instead of Redding)	1,810	1.16	292	2,102
California	Sacramento	1,810	1.17	314	2,124
California	San Francisco	1,810	1.26	465	2,275
Colorado	Denver	1,810	0.97	(57)	1,752
Connecticut	Hartford	1,810	1.14	252	2,062
Delaware	Dover	1,810	1.10	176	1,985
District of Columbia	Washington	1,810	1.02	42	1,852
Florida	Tallahassee	1,810	0.96	(80)	1,730
Florida	Tampa	1,810	0.97	(61)	1,749
Georgia	Atlanta	1,810	0.99	(17)	1,793
Idaho	Boise	1,810	1.02	36	1,846
Illinois	Chicago	1,810	1.21	382	2,191
Illinois	Joliet	1,810	1.18	320	2,129
Indiana	Indianapolis	1,810	1.02	37	1,846
Iowa	Davenport	1,810	1.04	66	1,876
Iowa	Waterloo	1,810	0.98	(33)	1,777
Kansas	Wichita	1,810	0.98	(27)	1,782
Kentucky	Louisville	1,810	1.01	13	1,823
Louisiana	New Orleans	1,810	0.98	(27)	1,782
Maine	Portland	1,810	1.01	27	1,836
Maryland	Baltimore	1,810	1.02	36	1,845
Massachusetts	Boston	1,810	1.18	320	2,129
Michigan	Detroit	1,810	1.09	161	1,971
Michigan	Grand Rapids	1,810	1.02	42	1,852
Minnesota	Saint Paul	1,810	1.08	148	1,958
Mississippi	Jackson	1,810	0.96	(78)	1,731
Missouri	St. Louis	1,810	1.12	210	2,019
Missouri	Kansas City	1,810	1.07	118	1,928
Montana	Great Falls	1,810	0.98	(39)	1,770
Nebraska	Omaha	1,810	0.99	(24)	1,785
New Hampshire	Concord	1,810	1.06	117	1,927
New Jersey	Newark	1,810	1.19	342	2,152
New Mexico	Albuquerque	1,810	1.00	1	1,811
New York	New York	1,810	1.37	673	2,483
New York	Syracuse	1,810	1.05	96	1,906
Nevada	Las Vegas	1,810	1.12	224	2,034
North Carolina	Charlotte	1,810	0.97	(56)	1,754
North Dakota	Bismarck	1,810	1.00	8	1,818
Oklahoma	Oklahoma City	1,810	1.00	2	1,811
Oklahoma	Tulsa	1,810	0.94	(101)	1,709
Ohio	Cincinnati	1,810	0.94	(101)	1,709
Oregon	Portland	1,810	1.09	157	1,966
Pennsylvania	Philadelphia	1,810	1.18	326	2,136
Pennsylvania	Wilkes-Barre	1,810	1.06	108	1,918
Rhode Island	Providence	1,810	1.12	217	2,027
South Carolina	Charleston	1,810	0.99	(15)	1,795
South Carolina	Spartanburg (Asheville, NC)	1,810	0.98	(39)	1,770
South Dakota	Rapid City	1,810	0.98	(40)	1,770
Tennessee	Knoxville (Nashville)	1,810	0.99	(15)	1,794
Texas	Houston	1,810	0.94	(108)	1,702
Utah	Salt Lake City	1,810	1.00	0	1,809
Vermont	Burlington	1,810	1.05	94	1,904
Virginia	Alexandria	1,810	1.02	35	1,844
Virginia	Lynchburg	1,810	0.97	(57)	1,753
Washington	Seattle	1,810	1.13	231	2,041
Washington	Spokane	1,810	1.04	65	1,874
West Virginia	Charleston	1,810	1.03	55	1,864
Wisconsin	Green Bay	1,810	1.03	55	1,865
Wyoming	Cheyenne	1,810	0.99	(18)	1,791

**Table 1 5 — Location Adjustment for Combined-Cycle Oil/Natural Gas Turbine  
(2019 Dollars)  
Case Configuration: 100 MW, 2 x LM6000**

State	City	Base Project Cost (\$/kW )	Location Variation	Delta Cost Difference (\$/kW)	Total Location Project Cost (\$/kW)
Alabama	Huntsville	1,175	0.96	(53)	1,122
Arizona	Phoenix	1,175	0.98	(26)	1,149
Arkansas	Little Rock	1,175	0.96	(49)	1,126
California	Bakersfield	1,175	1.16	192	1,367
California	Los Angeles	1,175	1.18	206	1,381
California	Modesto (instead of Redding)	1,175	1.17	199	1,374
California	Sacramento	1,175	1.19	218	1,393
California	San Francisco	1,175	1.31	359	1,534
Colorado	Denver	1,175	0.97	(39)	1,136
Connecticut	Hartford	1,175	1.15	172	1,347
Delaware	Dover	1,175	1.13	157	1,331
District of Columbia	Washington	1,175	1.02	28	1,203
Florida	Tallahassee	1,175	0.94	(67)	1,107
Florida	Tampa	1,175	0.96	(52)	1,123
Georgia	Atlanta	1,175	0.98	(29)	1,145
Idaho	Boise	1,175	1.01	14	1,189
Illinois	Chicago	1,175	1.23	270	1,445
Illinois	Joliet	1,175	1.20	234	1,409
Indiana	Indianapolis	1,175	1.01	9	1,184
Iowa	Davenport	1,175	1.03	39	1,214
Iowa	Waterloo	1,175	0.96	(41)	1,133
Kansas	Wichita	1,175	0.97	(38)	1,137
Kentucky	Louisville	1,175	0.99	(6)	1,168
Louisiana	New Orleans	1,175	0.96	(45)	1,130
Maine	Portland	1,175	1.00	6	1,181
Maryland	Baltimore	1,175	1.02	19	1,194
Massachusetts	Boston	1,175	1.20	229	1,404
Michigan	Detroit	1,175	1.11	128	1,303
Michigan	Grand Rapids	1,175	1.03	35	1,210
Minnesota	Saint Paul	1,175	1.09	106	1,281
Mississippi	Jackson	1,175	0.94	(65)	1,109
Missouri	St. Louis	1,175	1.11	129	1,304
Missouri	Kansas City	1,175	1.07	82	1,256
Montana	Great Falls	1,175	0.96	(42)	1,133
Nebraska	Omaha	1,175	0.97	(32)	1,142
New Hampshire	Concord	1,175	1.05	59	1,233
New Jersey	Newark	1,175	1.22	253	1,428
New Mexico	Albuquerque	1,175	0.98	(27)	1,148
New York	New York	1,175	1.43	500	1,675
New York	Syracuse	1,175	1.06	69	1,244
Nevada	Las Vegas	1,175	1.12	146	1,321
North Carolina	Charlotte	1,175	0.96	(49)	1,126
North Dakota	Bismarck	1,175	1.02	22	1,196
Oklahoma	Oklahoma City	1,175	1.00	(1)	1,173
Oklahoma	Tulsa	1,175	0.93	(82)	1,092
Ohio	Cincinnati	1,175	0.93	(83)	1,092
Oregon	Portland	1,175	1.08	96	1,271
Pennsylvania	Philadelphia	1,175	1.21	251	1,426
Pennsylvania	Wilkes-Barre	1,175	1.06	73	1,248
Rhode Island	Providence	1,175	1.12	138	1,313
South Carolina	Charleston	1,175	0.95	(55)	1,120
South Carolina	Spartanburg (Asheville, NC)	1,175	0.96	(47)	1,128
South Dakota	Rapid City	1,175	0.97	(33)	1,142
Tennessee	Knoxville (Nashville)	1,175	0.97	(31)	1,144
Texas	Houston	1,175	0.93	(84)	1,091
Utah	Salt Lake City	1,175	0.97	(34)	1,141
Vermont	Burlington	1,175	1.02	27	1,202
Virginia	Alexandria	1,175	1.02	21	1,195
Virginia	Lynchburg	1,175	0.96	(52)	1,123
Washington	Seattle	1,175	1.14	160	1,334
Washington	Spokane	1,175	1.04	45	1,220
West Virginia	Charleston	1,175	1.04	43	1,218
Wisconsin	Green Bay	1,175	1.04	44	1,219
Wyoming	Cheyenne	1,175	0.99	(14)	1,161

**Table 1 6 — Location Adjustment for Combined-Cycle Oil/Natural Gas Turbine  
(2019 Dollars)  
Case Configuration: 1 x 240 MW, F-Class**

State	City	Base Project Cost (\$/kW )	Location Variation	Delta Cost Difference (\$/kW)	Total Location Project Cost (\$/kW)
Alabama	Huntsville	713	0.95	(33)	680
Arizona	Phoenix	713	0.98	(16)	696
Arkansas	Little Rock	713	0.96	(30)	683
California	Bakersfield	713	1.17	122	834
California	Los Angeles	713	1.18	130	843
California	Modesto (instead of Redding)	713	1.18	126	839
California	Sacramento	713	1.19	138	851
California	San Francisco	713	1.32	227	940
Colorado	Denver	713	0.97	(25)	688
Connecticut	Hartford	713	1.15	109	821
Delaware	Dover	713	1.14	99	811
District of Columbia	Washington	713	1.03	18	731
Florida	Tallahassee	713	0.94	(42)	670
Florida	Tampa	713	0.95	(33)	680
Georgia	Atlanta	713	0.97	(18)	695
Idaho	Boise	713	1.01	9	722
Illinois	Chicago	713	1.24	170	883
Illinois	Joliet	713	1.21	147	860
Indiana	Indianapolis	713	1.01	6	719
Iowa	Davenport	713	1.03	25	738
Iowa	Waterloo	713	0.96	(26)	687
Kansas	Wichita	713	0.97	(24)	689
Kentucky	Louisville	713	0.99	(4)	709
Louisiana	New Orleans	713	0.96	(28)	685
Maine	Portland	713	1.01	4	717
Maryland	Baltimore	713	1.02	12	725
Massachusetts	Boston	713	1.20	145	857
Michigan	Detroit	713	1.11	81	794
Michigan	Grand Rapids	713	1.03	22	735
Minnesota	Saint Paul	713	1.09	66	779
Mississippi	Jackson	713	0.94	(41)	672
Missouri	St. Louis	713	1.12	82	795
Missouri	Kansas City	713	1.07	51	764
Montana	Great Falls	713	0.96	(27)	686
Nebraska	Omaha	713	0.97	(20)	692
New Hampshire	Concord	713	1.05	37	750
New Jersey	Newark	713	1.22	160	873
New Mexico	Albuquerque	713	0.98	(16)	696
New York	New York	713	1.44	315	1,028
New York	Syracuse	713	1.06	43	756
Nevada	Las Vegas	713	1.13	92	805
North Carolina	Charlotte	713	0.96	(31)	682
North Dakota	Bismarck	713	1.02	13	726
Oklahoma	Oklahoma City	713	1.00	(1)	712
Oklahoma	Tulsa	713	0.93	(52)	661
Ohio	Cincinnati	713	0.93	(52)	661
Oregon	Portland	713	1.09	61	774
Pennsylvania	Philadelphia	713	1.22	159	871
Pennsylvania	Wilkes-Barre	713	1.06	46	759
Rhode Island	Providence	713	1.12	88	800
South Carolina	Charleston	713	0.95	(33)	679
South Carolina	Spartanburg (Asheville, NC)	713	0.96	(29)	683
South Dakota	Rapid City	713	0.97	(21)	692
Tennessee	Knoxville (Nashville)	713	0.97	(19)	694
Texas	Houston	713	0.93	(53)	660
Utah	Salt Lake City	713	0.97	(21)	692
Vermont	Burlington	713	1.03	18	731
Virginia	Alexandria	713	1.02	13	726
Virginia	Lynchburg	713	0.95	(33)	680
Washington	Seattle	713	1.14	101	814
Washington	Spokane	713	1.04	29	742
West Virginia	Charleston	713	1.04	27	740
Wisconsin	Green Bay	713	1.04	27	740
Wyoming	Cheyenne	713	0.99	(9)	704

**Table 1 7 — Location Adjustment for Combined-Cycle Oil/Natural Gas Turbine  
(2019 Dollars)  
Case Configuration: 1100 MW, H-Class, 2x2x1**

State	City	Base Project Cost (\$/kW )	Location Variation	Delta Cost Difference (\$/kW)	Total Location Project Cost (\$/kW)
Alabama	Huntsville	958	0.95	(51)	907
Arizona	Phoenix	958	1.05	50	1,008
Arkansas	Little Rock	958	0.95	(49)	910
California	Bakersfield	958	1.28	270	1,229
California	Los Angeles	958	1.30	285	1,243
California	Modesto (instead of Redding)	958	1.29	278	1,236
California	Sacramento	958	1.31	298	1,256
California	San Francisco	958	1.46	442	1,401
Colorado	Denver	958	1.04	36	994
Connecticut	Hartford	958	1.26	252	1,210
Delaware	Dover	958	1.25	238	1,196
District of Columbia	Washington	958	1.11	104	1,063
Florida	Tallahassee	958	0.93	(64)	894
Florida	Tampa	958	0.95	(50)	908
Georgia	Atlanta	958	0.97	(29)	929
Idaho	Boise	958	1.01	13	971
Illinois	Chicago	958	1.27	257	1,216
Illinois	Joliet	958	1.23	223	1,181
Indiana	Indianapolis	958	1.01	8	966
Iowa	Davenport	958	1.04	38	996
Iowa	Waterloo	958	0.96	(40)	919
Kansas	Wichita	958	0.96	(36)	922
Kentucky	Louisville	958	0.99	(7)	951
Louisiana	New Orleans	958	0.95	(45)	913
Maine	Portland	958	1.01	5	963
Maryland	Baltimore	958	1.02	18	977
Massachusetts	Boston	958	1.32	310	1,269
Michigan	Detroit	958	1.13	122	1,081
Michigan	Grand Rapids	958	1.03	33	992
Minnesota	Saint Paul	958	1.11	102	1,061
Mississippi	Jackson	958	0.93	(62)	896
Missouri	St. Louis	958	1.13	120	1,079
Missouri	Kansas City	958	1.08	78	1,036
Montana	Great Falls	958	0.96	(40)	919
Nebraska	Omaha	958	0.97	(31)	927
New Hampshire	Concord	958	1.14	134	1,092
New Jersey	Newark	958	1.25	241	1,200
New Mexico	Albuquerque	958	0.97	(28)	931
New York	New York	958	1.61	589	1,548
New York	Syracuse	958	1.15	146	1,105
Nevada	Las Vegas	958	1.14	137	1,095
North Carolina	Charlotte	958	0.95	(47)	912
North Dakota	Bismarck	958	1.02	22	980
Oklahoma	Oklahoma City	958	1.00	(1)	957
Oklahoma	Tulsa	958	0.92	(78)	880
Ohio	Cincinnati	958	0.92	(79)	880
Oregon	Portland	958	1.09	90	1,048
Pennsylvania	Philadelphia	958	1.35	333	1,292
Pennsylvania	Wilkes-Barre	958	1.16	150	1,109
Rhode Island	Providence	958	1.23	217	1,175
South Carolina	Charleston	958	0.94	(57)	901
South Carolina	Spartanburg (Asheville, NC)	958	0.95	(46)	912
South Dakota	Rapid City	958	0.97	(30)	929
Tennessee	Knoxville (Nashville)	958	0.97	(32)	927
Texas	Houston	958	0.92	(80)	878
Utah	Salt Lake City	958	0.96	(35)	924
Vermont	Burlington	958	1.02	21	979
Virginia	Alexandria	958	1.10	96	1,055
Virginia	Lynchburg	958	1.02	22	981
Washington	Seattle	958	1.16	150	1,108
Washington	Spokane	958	1.04	42	1,001
West Virginia	Charleston	958	1.04	41	999
Wisconsin	Green Bay	958	1.05	43	1,002
Wyoming	Cheyenne	958	0.99	(13)	945

**Table 1 8 — Location Adjustment for Combined-Cycle Single Shaft  
(2019 Dollars)  
Case Configuration: 430 MW, H-Class 1x1x1**

State	City	Base Project Cost (\$/kW )	Location Variation	Delta Cost Difference (\$/kW)	Total Location Project Cost (\$/kW)
Alabama	Huntsville	1,084	0.96	(49)	1,035
Arizona	Phoenix	1,084	1.10	114	1,197
Arkansas	Little Rock	1,084	0.96	(47)	1,036
California	Bakersfield	1,084	1.30	324	1,407
California	Los Angeles	1,084	1.31	337	1,421
California	Modesto (instead of Redding)	1,084	1.31	331	1,415
California	Sacramento	1,084	1.32	350	1,434
California	San Francisco	1,084	1.45	489	1,573
Colorado	Denver	1,084	1.09	100	1,184
Connecticut	Hartford	1,084	1.28	308	1,391
Delaware	Dover	1,084	1.27	296	1,380
District of Columbia	Washington	1,084	1.15	166	1,249
Florida	Tallahassee	1,084	0.94	(60)	1,024
Florida	Tampa	1,084	0.96	(47)	1,037
Georgia	Atlanta	1,084	0.97	(28)	1,056
Idaho	Boise	1,084	1.01	11	1,095
Illinois	Chicago	1,084	1.22	238	1,322
Illinois	Joliet	1,084	1.19	206	1,290
Indiana	Indianapolis	1,084	1.01	6	1,090
Iowa	Davenport	1,084	1.03	35	1,119
Iowa	Waterloo	1,084	0.97	(37)	1,047
Kansas	Wichita	1,084	0.97	(34)	1,050
Kentucky	Louisville	1,084	0.99	(8)	1,076
Louisiana	New Orleans	1,084	0.96	(43)	1,040
Maine	Portland	1,084	1.00	4	1,088
Maryland	Baltimore	1,084	1.02	17	1,100
Massachusetts	Boston	1,084	1.34	364	1,447
Michigan	Detroit	1,084	1.10	113	1,197
Michigan	Grand Rapids	1,084	1.03	31	1,115
Minnesota	Saint Paul	1,084	1.09	96	1,180
Mississippi	Jackson	1,084	0.95	(58)	1,026
Missouri	St. Louis	1,084	1.10	108	1,192
Missouri	Kansas City	1,084	1.07	72	1,156
Montana	Great Falls	1,084	0.97	(36)	1,047
Nebraska	Omaha	1,084	0.97	(29)	1,055
New Hampshire	Concord	1,084	1.18	192	1,276
New Jersey	Newark	1,084	1.21	223	1,306
New Mexico	Albuquerque	1,084	0.97	(27)	1,056
New York	New York	1,084	1.58	634	1,717
New York	Syracuse	1,084	1.19	206	1,290
Nevada	Las Vegas	1,084	1.11	124	1,208
North Carolina	Charlotte	1,084	0.96	(43)	1,040
North Dakota	Bismarck	1,084	1.02	22	1,105
Oklahoma	Oklahoma City	1,084	1.00	(1)	1,083
Oklahoma	Tulsa	1,084	0.93	(72)	1,011
Ohio	Cincinnati	1,084	0.93	(72)	1,011
Oregon	Portland	1,084	1.21	229	1,313
Pennsylvania	Philadelphia	1,084	1.36	387	1,470
Pennsylvania	Wilkes-Barre	1,084	1.19	210	1,294
Rhode Island	Providence	1,084	1.25	273	1,357
South Carolina	Charleston	1,084	0.95	(57)	1,027
South Carolina	Spartanburg (Asheville, NC)	1,084	0.96	(43)	1,040
South Dakota	Rapid City	1,084	0.98	(26)	1,058
Tennessee	Knoxville (Nashville)	1,084	0.97	(32)	1,052
Texas	Houston	1,084	0.93	(74)	1,009
Utah	Salt Lake City	1,084	0.97	(34)	1,050
Vermont	Burlington	1,084	1.01	15	1,098
Virginia	Alexandria	1,084	1.15	158	1,242
Virginia	Lynchburg	1,084	1.08	87	1,171
Washington	Seattle	1,084	1.13	136	1,220
Washington	Spokane	1,084	1.03	38	1,122
West Virginia	Charleston	1,084	1.04	38	1,122
Wisconsin	Green Bay	1,084	1.04	42	1,126
Wyoming	Cheyenne	1,084	0.99	(11)	1,072

**Table 1 9 — Location Adjustment for Combined-Cycle Gas Turbine (with 90% CCS)**  
**(2019 Dollars)**

**Case Configuration: 430 MW, H-Class 1x1x1**

State	City	Base Project Cost (\$/kW )	Location Variation	Delta Cost Difference (\$/kW)	Total Location Project Cost (\$/kW)
Alabama	Huntsville	2,481	0.98	(49)	2,432
Arizona	Phoenix	2,481	0.99	(26)	2,454
Arkansas	Little Rock	2,481	0.98	(42)	2,439
California	Bakersfield	2,481	1.08	191	2,672
California	Los Angeles	2,481	1.08	205	2,685
California	Modesto (instead of Redding)	2,481	1.08	198	2,679
California	Sacramento	2,481	1.09	217	2,697
California	San Francisco	2,481	1.14	353	2,834
Colorado	Denver	2,481	0.98	(39)	2,442
Connecticut	Hartford	2,481	1.07	169	2,650
Delaware	Dover	2,481	1.06	152	2,632
District of Columbia	Washington	2,481	1.01	28	2,509
Florida	Tallahassee	2,481	0.97	(66)	2,415
Florida	Tampa	2,481	0.98	(50)	2,431
Georgia	Atlanta	2,481	0.99	(26)	2,454
Idaho	Boise	2,481	1.01	15	2,496
Illinois	Chicago	2,481	1.11	264	2,745
Illinois	Joliet	2,481	1.09	228	2,709
Indiana	Indianapolis	2,481	1.00	12	2,492
Iowa	Davenport	2,481	1.02	38	2,519
Iowa	Waterloo	2,481	0.98	(41)	2,440
Kansas	Wichita	2,481	0.98	(38)	2,443
Kentucky	Louisville	2,481	1.00	(4)	2,477
Louisiana	New Orleans	2,481	0.98	(40)	2,441
Maine	Portland	2,481	1.00	6	2,487
Maryland	Baltimore	2,481	1.01	19	2,500
Massachusetts	Boston	2,481	1.09	225	2,706
Michigan	Detroit	2,481	1.05	125	2,606
Michigan	Grand Rapids	2,481	1.01	34	2,515
Minnesota	Saint Paul	2,481	1.04	101	2,582
Mississippi	Jackson	2,481	0.97	(64)	2,417
Missouri	St. Louis	2,481	1.05	131	2,612
Missouri	Kansas City	2,481	1.03	80	2,561
Montana	Great Falls	2,481	0.98	(42)	2,439
Nebraska	Omaha	2,481	0.99	(31)	2,449
New Hampshire	Concord	2,481	1.02	61	2,542
New Jersey	Newark	2,481	1.10	248	2,729
New Mexico	Albuquerque	2,481	0.99	(22)	2,459
New York	New York	2,481	1.20	489	2,970
New York	Syracuse	2,481	1.03	67	2,548
Nevada	Las Vegas	2,481	1.06	146	2,627
North Carolina	Charlotte	2,481	0.98	(48)	2,433
North Dakota	Bismarck	2,481	1.01	19	2,499
Oklahoma	Oklahoma City	2,481	1.00	(2)	2,479
Oklahoma	Tulsa	2,481	0.97	(81)	2,400
Ohio	Cincinnati	2,481	0.97	(81)	2,400
Oregon	Portland	2,481	1.04	98	2,579
Pennsylvania	Philadelphia	2,481	1.10	246	2,727
Pennsylvania	Wilkes-Barre	2,481	1.03	72	2,552
Rhode Island	Providence	2,481	1.06	137	2,618
South Carolina	Charleston	2,481	0.98	(42)	2,438
South Carolina	Spartanburg (Asheville, NC)	2,481	0.98	(44)	2,437
South Dakota	Rapid City	2,481	0.99	(35)	2,446
Tennessee	Knoxville (Nashville)	2,481	0.99	(25)	2,456
Texas	Houston	2,481	0.97	(82)	2,399
Utah	Salt Lake City	2,481	0.99	(28)	2,453
Vermont	Burlington	2,481	1.01	35	2,516
Virginia	Alexandria	2,481	1.01	21	2,502
Virginia	Lynchburg	2,481	0.98	(51)	2,430
Washington	Seattle	2,481	1.06	160	2,641
Washington	Spokane	2,481	1.02	46	2,527
West Virginia	Charleston	2,481	1.02	42	2,523
Wisconsin	Green Bay	2,481	1.02	40	2,521
Wyoming	Cheyenne	2,481	0.99	(15)	2,466



**Table 1 10 — Location Adjustment for Fuel Cell (Molten Carbonate or Other Commercially Viable Technology)**  
**(2019 Dollars)**  
**Case Configuration: 10 MW (4 x 2.8 MW MCFC)**

State	City	Base Project Cost (\$/kW )	Location Variation	Delta Cost Difference (\$/kW)	Total Location Project Cost (\$/kW)
Alabama	Huntsville	6,700	0.99	(66)	6,634
Arizona	Phoenix	6,700	0.99	(74)	6,626
Arkansas	Little Rock	6,700	1.00	10	6,710
California	Bakersfield	6,700	1.13	858	7,558
California	Los Angeles	6,700	1.14	907	7,607
California	Modesto (instead of Redding)	6,700	1.13	892	7,592
California	Sacramento	6,700	1.14	953	7,652
California	San Francisco	6,700	1.19	1,284	7,983
Colorado	Denver	6,700	0.98	(157)	6,543
Connecticut	Hartford	6,700	1.11	729	7,429
Delaware	Dover	6,700	1.07	463	7,163
District of Columbia	Washington	6,700	1.02	144	6,844
Florida	Tallahassee	6,700	0.97	(205)	6,495
Florida	Tampa	6,700	0.98	(136)	6,564
Georgia	Atlanta	6,700	1.00	32	6,731
Idaho	Boise	6,700	1.02	147	6,847
Illinois	Chicago	6,700	1.16	1,051	7,750
Illinois	Joliet	6,700	1.13	874	7,573
Indiana	Indianapolis	6,700	1.02	161	6,861
Iowa	Davenport	6,700	1.03	190	6,890
Iowa	Waterloo	6,700	0.99	(63)	6,637
Kansas	Wichita	6,700	0.99	(57)	6,643
Kentucky	Louisville	6,700	1.01	97	6,797
Louisiana	New Orleans	6,700	1.00	14	6,713
Maine	Portland	6,700	1.01	97	6,797
Maryland	Baltimore	6,700	1.02	131	6,831
Massachusetts	Boston	6,700	1.14	905	7,605
Michigan	Detroit	6,700	1.07	455	7,154
Michigan	Grand Rapids	6,700	1.02	119	6,819
Minnesota	Saint Paul	6,700	1.06	391	7,091
Mississippi	Jackson	6,700	0.97	(205)	6,495
Missouri	St. Louis	6,700	1.10	684	7,384
Missouri	Kansas City	6,700	1.05	338	7,038
Montana	Great Falls	6,700	0.98	(106)	6,594
Nebraska	Omaha	6,700	0.99	(39)	6,661
New Hampshire	Concord	6,700	1.07	450	7,150
New Jersey	Newark	6,700	1.14	961	7,661
New Mexico	Albuquerque	6,700	1.02	108	6,808
New York	New York	6,700	1.27	1,834	8,533
New York	Syracuse	6,700	1.04	254	6,954
Nevada	Las Vegas	6,700	1.10	693	7,393
North Carolina	Charlotte	6,700	0.98	(138)	6,562
North Dakota	Bismarck	6,700	1.00	9	6,708
Oklahoma	Oklahoma City	6,700	1.00	0	6,700
Oklahoma	Tulsa	6,700	0.96	(268)	6,431
Ohio	Cincinnati	6,700	0.96	(270)	6,430
Oregon	Portland	6,700	1.07	496	7,196
Pennsylvania	Philadelphia	6,700	1.13	892	7,592
Pennsylvania	Wilkes-Barre	6,700	1.05	325	7,024
Rhode Island	Providence	6,700	1.10	650	7,349
South Carolina	Charleston	6,700	1.02	156	6,856
South Carolina	Spartanburg (Asheville, NC)	6,700	0.99	(56)	6,644
South Dakota	Rapid City	6,700	0.98	(111)	6,589
Tennessee	Knoxville (Nashville)	6,700	1.01	51	6,751
Texas	Houston	6,700	0.96	(270)	6,429
Utah	Salt Lake City	6,700	1.02	113	6,813
Vermont	Burlington	6,700	1.07	458	7,157
Virginia	Alexandria	6,700	1.02	124	6,824
Virginia	Lynchburg	6,700	0.98	(118)	6,582
Washington	Seattle	6,700	1.11	705	7,405
Washington	Spokane	6,700	1.04	243	6,943
West Virginia	Charleston	6,700	1.02	149	6,848
Wisconsin	Green Bay	6,700	1.02	113	6,812
Wyoming	Cheyenne	6,700	0.99	(66)	6,633

**Table 1 11 — Location Adjustment for Advanced Nuclear AP 1000 (Brownfield Site)**  
(2019 Dollars)

Case Configuration: 2 x 1117 MW, PWR

State	City	Base Project Cost (\$/kW )	Location Variation	Delta Cost Difference (\$/kW)	Total Location Project Cost (\$/kW)
Alabama	Huntsville	6,041	0.99	(53)	5,988
Arizona	Phoenix	6,041	0.98	(147)	5,894
Arkansas	Little Rock	6,041	1.02	122	6,163
California	Bakersfield	6,041	1.22	1,305	7,346
California	Los Angeles	6,041	1.22	1,339	7,380
California	Modesto (instead of Redding)	6,041	1.22	1,358	7,399
California	Sacramento	6,041	1.24	1,443	7,484
California	San Francisco	6,041	1.30	1,830	7,871
Colorado	Denver	6,041	0.96	(227)	5,815
Connecticut	Hartford	6,041	1.16	946	6,987
Delaware	Dover	6,041	1.10	602	6,643
District of Columbia	Washington	6,041	1.02	146	6,188
Florida	Tallahassee	6,041	0.95	(280)	5,761
Florida	Tampa	6,041	0.97	(151)	5,890
Georgia	Atlanta	6,041	1.01	61	6,103
Idaho	Boise	6,041	1.04	258	6,300
Illinois	Chicago	6,041	1.23	1,415	7,456
Illinois	Joliet	6,041	1.20	1,207	7,249
Indiana	Indianapolis	6,041	1.05	274	6,315
Iowa	Davenport	6,041	1.04	231	6,272
Iowa	Waterloo	6,041	0.98	(134)	5,907
Kansas	Wichita	6,041	0.98	(130)	5,912
Kentucky	Louisville	6,041	1.03	204	6,245
Louisiana	New Orleans	6,041	1.02	95	6,137
Maine	Portland	6,041	1.04	217	6,258
Maryland	Baltimore	6,041	1.03	160	6,202
Massachusetts	Boston	6,041	1.20	1,216	7,257
Michigan	Detroit	6,041	1.10	634	6,675
Michigan	Grand Rapids	6,041	1.04	225	6,267
Minnesota	Saint Paul	6,041	1.06	389	6,430
Mississippi	Jackson	6,041	0.95	(294)	5,747
Missouri	St. Louis	6,041	1.18	1,061	7,103
Missouri	Kansas City	6,041	1.07	418	6,459
Montana	Great Falls	6,041	0.97	(186)	5,855
Nebraska	Omaha	6,041	0.98	(100)	5,941
New Hampshire	Concord	6,041	1.11	649	6,690
New Jersey	Newark	6,041	1.21	1,297	7,338
New Mexico	Albuquerque	6,041	1.03	196	6,237
New York	New York	6,041	1.42	2,560	8,601
New York	Syracuse	6,041	1.06	344	6,385
Nevada	Las Vegas	6,041	1.18	1,095	7,136
North Carolina	Charlotte	6,041	0.97	(203)	5,838
North Dakota	Bismarck	6,041	1.00	(4)	6,037
Oklahoma	Oklahoma City	6,041	1.00	4	6,045
Oklahoma	Tulsa	6,041	0.94	(387)	5,654
Ohio	Cincinnati	6,041	0.94	(389)	5,652
Oregon	Portland	6,041	1.13	777	6,818
Pennsylvania	Philadelphia	6,041	1.20	1,204	7,245
Pennsylvania	Wilkes-Barre	6,041	1.08	463	6,504
Rhode Island	Providence	6,041	1.15	893	6,935
South Carolina	Charleston	6,041	1.07	407	6,448
South Carolina	Spartanburg (Asheville, NC)	6,041	0.99	(50)	5,992
South Dakota	Rapid City	6,041	0.95	(287)	5,754
Tennessee	Knoxville (Nashville)	6,041	1.03	197	6,238
Texas	Houston	6,041	0.94	(339)	5,703
Utah	Salt Lake City	6,041	1.04	239	6,280
Vermont	Burlington	6,041	1.15	892	6,933
Virginia	Alexandria	6,041	1.02	110	6,151
Virginia	Lynchburg	6,041	0.96	(214)	5,827
Washington	Seattle	6,041	1.18	1,059	7,100
Washington	Spokane	6,041	1.07	447	6,488
West Virginia	Charleston	6,041	1.03	210	6,252
Wisconsin	Green Bay	6,041	1.01	63	6,105
Wyoming	Cheyenne	6,041	0.98	(107)	5,935

**Table 1 12 — Location Adjustment for Small Modular Reactor (SMR) Nuclear Power Plant  
(2019 Dollars)  
Case Configuration: 600 MW**

State	City	Base Project Cost (\$/kW )	Location Variation	Delta Cost Difference (\$/kW)	Total Location Project Cost (\$/kW)
Alabama	Huntsville	6,191	0.97	(204)	5,987
Arizona	Phoenix	6,191	0.98	(97)	6,094
Arkansas	Little Rock	6,191	0.97	(166)	6,025
California	Bakersfield	6,191	1.20	1,242	7,433
California	Los Angeles	6,191	1.21	1,270	7,461
California	Modesto (instead of Redding)	6,191	1.21	1,309	7,500
California	Sacramento	6,191	1.23	1,402	7,593
California	San Francisco	6,191	1.30	1,855	8,046
Colorado	Denver	6,191	0.97	(212)	5,979
Connecticut	Hartford	6,191	1.17	1,033	7,224
Delaware	Dover	6,191	1.14	850	7,041
District of Columbia	Washington	6,191	1.02	135	6,326
Florida	Tallahassee	6,191	0.94	(345)	5,845
Florida	Tampa	6,191	0.96	(228)	5,963
Georgia	Atlanta	6,191	0.99	(70)	6,121
Idaho	Boise	6,191	1.03	202	6,392
Illinois	Chicago	6,191	1.27	1,673	7,864
Illinois	Joliet	6,191	1.23	1,429	7,620
Indiana	Indianapolis	6,191	1.03	165	6,356
Iowa	Davenport	6,191	1.05	282	6,473
Iowa	Waterloo	6,191	0.97	(160)	6,031
Kansas	Wichita	6,191	0.98	(142)	6,049
Kentucky	Louisville	6,191	1.01	85	6,276
Louisiana	New Orleans	6,191	0.98	(135)	6,056
Maine	Portland	6,191	1.03	202	6,393
Maryland	Baltimore	6,191	1.02	151	6,342
Massachusetts	Boston	6,191	1.21	1,311	7,502
Michigan	Detroit	6,191	1.12	754	6,944
Michigan	Grand Rapids	6,191	1.04	274	6,465
Minnesota	Saint Paul	6,191	1.10	628	6,819
Mississippi	Jackson	6,191	0.95	(340)	5,851
Missouri	St. Louis	6,191	1.14	867	7,058
Missouri	Kansas City	6,191	1.08	490	6,681
Montana	Great Falls	6,191	0.97	(182)	6,009
Nebraska	Omaha	6,191	0.98	(126)	6,065
New Hampshire	Concord	6,191	1.08	510	6,701
New Jersey	Newark	6,191	1.24	1,467	7,658
New Mexico	Albuquerque	6,191	0.99	(37)	6,154
New York	New York	6,191	1.47	2,941	9,132
New York	Syracuse	6,191	1.07	404	6,595
Nevada	Las Vegas	6,191	1.16	999	7,189
North Carolina	Charlotte	6,191	0.96	(238)	5,953
North Dakota	Bismarck	6,191	1.03	170	6,361
Oklahoma	Oklahoma City	6,191	1.01	40	6,231
Oklahoma	Tulsa	6,191	0.93	(436)	5,755
Ohio	Cincinnati	6,191	0.93	(438)	5,753
Oregon	Portland	6,191	1.10	634	6,825
Pennsylvania	Philadelphia	6,191	1.22	1,359	7,550
Pennsylvania	Wilkes-Barre	6,191	1.08	525	6,716
Rhode Island	Providence	6,191	1.15	902	7,093
South Carolina	Charleston	6,191	0.98	(127)	6,064
South Carolina	Spartanburg (Asheville, NC)	6,191	0.97	(187)	6,004
South Dakota	Rapid City	6,191	0.97	(168)	6,023
Tennessee	Knoxville (Nashville)	6,191	0.99	(84)	6,107
Texas	Houston	6,191	0.93	(422)	5,769
Utah	Salt Lake City	6,191	1.00	(16)	6,175
Vermont	Burlington	6,191	1.07	444	6,635
Virginia	Alexandria	6,191	1.01	93	6,284
Virginia	Lynchburg	6,191	0.96	(245)	5,946
Washington	Seattle	6,191	1.15	923	7,114
Washington	Spokane	6,191	1.06	385	6,576
West Virginia	Charleston	6,191	1.04	263	6,454
Wisconsin	Green Bay	6,191	1.05	285	6,476
Wyoming	Cheyenne	6,191	0.99	(53)	6,138

**Table 1 13 — Location Adjustment for Dedicated Biomass Plant  
(2019 Dollars)  
Case Configuration: 50 MW, Wood**

State	City	Base Project Cost (\$/kW )	Location Variation	Delta Cost Difference (\$/kW)	Total Location Project Cost (\$/kW)
Alabama	Huntsville	4,097	0.96	(160)	3,937
Arizona	Phoenix	4,097	1.11	457	4,554
Arkansas	Little Rock	4,097	0.96	(144)	3,953
California	Bakersfield	4,097	1.30	1,247	5,344
California	Los Angeles	4,097	1.32	1,318	5,415
California	Modesto (instead of Redding)	4,097	1.31	1,259	5,356
California	Sacramento	4,097	1.33	1,360	5,457
California	San Francisco	4,097	1.47	1,907	6,004
Colorado	Denver	4,097	1.09	381	4,478
Connecticut	Hartford	4,097	1.29	1,203	5,300
Delaware	Dover	4,097	1.27	1,124	5,221
District of Columbia	Washington	4,097	1.17	685	4,782
Florida	Tallahassee	4,097	0.95	(214)	3,883
Florida	Tampa	4,097	0.96	(170)	3,927
Georgia	Atlanta	4,097	0.98	(71)	4,026
Idaho	Boise	4,097	1.02	73	4,170
Illinois	Chicago	4,097	1.23	947	5,044
Illinois	Joliet	4,097	1.20	806	4,903
Indiana	Indianapolis	4,097	1.02	77	4,174
Iowa	Davenport	4,097	1.04	153	4,250
Iowa	Waterloo	4,097	0.98	(96)	4,001
Kansas	Wichita	4,097	0.98	(81)	4,016
Kentucky	Louisville	4,097	1.00	(2)	4,095
Louisiana	New Orleans	4,097	0.97	(127)	3,970
Maine	Portland	4,097	1.02	72	4,169
Maryland	Baltimore	4,097	1.03	121	4,218
Massachusetts	Boston	4,097	1.34	1,403	5,500
Michigan	Detroit	4,097	1.10	418	4,515
Michigan	Grand Rapids	4,097	1.03	142	4,240
Minnesota	Saint Paul	4,097	1.09	385	4,482
Mississippi	Jackson	4,097	0.95	(210)	3,887
Missouri	St. Louis	4,097	1.11	464	4,562
Missouri	Kansas City	4,097	1.07	291	4,388
Montana	Great Falls	4,097	0.97	(106)	3,991
Nebraska	Omaha	4,097	0.99	(52)	4,045
New Hampshire	Concord	4,097	1.19	774	4,872
New Jersey	Newark	4,097	1.22	891	4,988
New Mexico	Albuquerque	4,097	1.00	(1)	4,096
New York	New York	4,097	1.61	2,505	6,602
New York	Syracuse	4,097	1.19	782	4,879
Nevada	Las Vegas	4,097	1.14	553	4,650
North Carolina	Charlotte	4,097	0.96	(161)	3,936
North Dakota	Bismarck	4,097	1.01	56	4,153
Oklahoma	Oklahoma City	4,097	1.00	(12)	4,085
Oklahoma	Tulsa	4,097	0.93	(272)	3,825
Ohio	Cincinnati	4,097	0.93	(273)	3,824
Oregon	Portland	4,097	1.22	919	5,016
Pennsylvania	Philadelphia	4,097	1.37	1,531	5,629
Pennsylvania	Wilkes-Barre	4,097	1.21	853	4,950
Rhode Island	Providence	4,097	1.26	1,055	5,152
South Carolina	Charleston	4,097	0.96	(151)	3,946
South Carolina	Spartanburg (Asheville, NC)	4,097	0.97	(124)	3,973
South Dakota	Rapid City	4,097	0.98	(66)	4,031
Tennessee	Knoxville (Nashville)	4,097	0.97	(124)	3,973
Texas	Houston	4,097	0.93	(297)	3,801
Utah	Salt Lake City	4,097	0.98	(65)	4,032
Vermont	Burlington	4,097	1.02	93	4,190
Virginia	Alexandria	4,097	1.16	661	4,758
Virginia	Lynchburg	4,097	1.09	353	4,451
Washington	Seattle	4,097	1.13	542	4,639
Washington	Spokane	4,097	1.04	144	4,241
West Virginia	Charleston	4,097	1.04	152	4,249
Wisconsin	Green Bay	4,097	1.04	154	4,251
Wyoming	Cheyenne	4,097	1.00	(6)	4,091

**Table 1 14 — Location Adjustment for Biomass Co-firing Retrofit onto Existing Coal Plant  
(2019 Dollars)**

**Case Configuration: 300 MW<sub>net</sub> with 30 MW of Added Biomass**

State	City	Base Project Cost (\$/kW )	Location Variation	Delta Cost Difference (\$/kW)	Total Location Project Cost (\$/kW)
Alabama	Huntsville	705	0.94	(43)	662
Arizona	Phoenix	705	0.98	(15)	690
Arkansas	Little Rock	705	0.94	(41)	664
California	Bakersfield	705	1.21	145	850
California	Los Angeles	705	1.23	159	864
California	Modesto (instead of Redding)	705	1.21	148	852
California	Sacramento	705	1.24	168	873
California	San Francisco	705	1.39	278	983
Colorado	Denver	705	0.96	(25)	680
Connecticut	Hartford	705	1.20	138	843
Delaware	Dover	705	1.18	125	830
District of Columbia	Washington	705	1.05	35	740
Florida	Tallahassee	705	0.92	(53)	652
Florida	Tampa	705	0.94	(44)	661
Georgia	Atlanta	705	0.97	(23)	682
Idaho	Boise	705	1.02	15	720
Illinois	Chicago	705	1.30	214	919
Illinois	Joliet	705	1.26	182	887
Indiana	Indianapolis	705	1.02	15	720
Iowa	Davenport	705	1.05	35	740
Iowa	Waterloo	705	0.97	(22)	683
Kansas	Wichita	705	0.97	(18)	687
Kentucky	Louisville	705	1.00	(2)	702
Louisiana	New Orleans	705	0.95	(36)	668
Maine	Portland	705	1.02	16	720
Maryland	Baltimore	705	1.04	27	732
Massachusetts	Boston	705	1.25	178	883
Michigan	Detroit	705	1.13	95	799
Michigan	Grand Rapids	705	1.05	32	737
Minnesota	Saint Paul	705	1.13	89	794
Mississippi	Jackson	705	0.93	(52)	653
Missouri	St. Louis	705	1.14	101	806
Missouri	Kansas City	705	1.09	66	770
Montana	Great Falls	705	0.97	(24)	681
Nebraska	Omaha	705	0.98	(12)	693
New Hampshire	Concord	705	1.07	50	755
New Jersey	Newark	705	1.28	201	905
New Mexico	Albuquerque	705	0.99	(8)	696
New York	New York	705	1.57	400	1,105
New York	Syracuse	705	1.08	55	759
Nevada	Las Vegas	705	1.17	122	827
North Carolina	Charlotte	705	0.95	(36)	668
North Dakota	Bismarck	705	1.02	15	719
Oklahoma	Oklahoma City	705	1.00	(2)	702
Oklahoma	Tulsa	705	0.91	(61)	644
Ohio	Cincinnati	705	0.91	(61)	643
Oregon	Portland	705	1.11	79	784
Pennsylvania	Philadelphia	705	1.29	205	909
Pennsylvania	Wilkes-Barre	705	1.10	69	774
Rhode Island	Providence	705	1.15	108	813
South Carolina	Charleston	705	0.93	(46)	658
South Carolina	Spartanburg (Asheville, NC)	705	0.95	(34)	670
South Dakota	Rapid City	705	0.98	(13)	692
Tennessee	Knoxville (Nashville)	705	0.95	(32)	673
Texas	Houston	705	0.90	(67)	638
Utah	Salt Lake City	705	0.97	(18)	687
Vermont	Burlington	705	1.02	14	719
Virginia	Alexandria	705	1.04	30	735
Virginia	Lynchburg	705	0.96	(31)	673
Washington	Seattle	705	1.17	119	824
Washington	Spokane	705	1.04	31	736
West Virginia	Charleston	705	1.05	35	739
Wisconsin	Green Bay	705	1.05	37	742
Wyoming	Cheyenne	705	1.00	(1)	704

**Table 1 15 — Location Adjustment for Geothermal (Representative Plant Excluding Exploration and Production of Resource)** Attachment D  
**(2019 Dollars)**  
**Case Configuration: 50 MW**

State	City	Base Project Cost (\$/kW )	Location Variation	Delta Cost Difference (\$/kW)	Total Location Project Cost (\$/kW)
Alabama	Huntsville	N/A	N/A	N/A	N/A
Arizona	Phoenix	N/A	N/A	N/A	N/A
Arkansas	Little Rock	N/A	N/A	N/A	N/A
California	Bakersfield	2,521	1.14	356	2,877
California	Los Angeles	2,521	1.15	377	2,898
California	Modesto (instead of Redding)	2,521	1.15	373	2,894
California	Sacramento	2,521	1.16	401	2,922
California	San Francisco	2,521	1.22	560	3,081
Colorado	Denver	N/A	N/A	N/A	N/A
Connecticut	Hartford	N/A	N/A	N/A	N/A
Delaware	Dover	N/A	N/A	N/A	N/A
District of Columbia	Washington	N/A	N/A	N/A	N/A
Florida	Tallahassee	N/A	N/A	N/A	N/A
Florida	Tampa	N/A	N/A	N/A	N/A
Georgia	Atlanta	N/A	N/A	N/A	N/A
Idaho	Boise	2,521	1.02	50	2,571
Illinois	Chicago	N/A	N/A	N/A	N/A
Illinois	Joliet	N/A	N/A	N/A	N/A
Indiana	Indianapolis	N/A	N/A	N/A	N/A
Iowa	Davenport	N/A	N/A	N/A	N/A
Iowa	Waterloo	N/A	N/A	N/A	N/A
Kansas	Wichita	N/A	N/A	N/A	N/A
Kentucky	Louisville	N/A	N/A	N/A	N/A
Louisiana	New Orleans	N/A	N/A	N/A	N/A
Maine	Portland	N/A	N/A	N/A	N/A
Maryland	Baltimore	N/A	N/A	N/A	N/A
Massachusetts	Boston	N/A	N/A	N/A	N/A
Michigan	Detroit	N/A	N/A	N/A	N/A
Michigan	Grand Rapids	N/A	N/A	N/A	N/A
Minnesota	Saint Paul	N/A	N/A	N/A	N/A
Mississippi	Jackson	N/A	N/A	N/A	N/A
Missouri	St. Louis	N/A	N/A	N/A	N/A
Missouri	Kansas City	N/A	N/A	N/A	N/A
Montana	Great Falls	N/A	N/A	N/A	N/A
Nebraska	Omaha	N/A	N/A	N/A	N/A
New Hampshire	Concord	N/A	N/A	N/A	N/A
New Jersey	Newark	N/A	N/A	N/A	N/A
New Mexico	Albuquerque	N/A	N/A	N/A	N/A
New York	New York	N/A	N/A	N/A	N/A
New York	Syracuse	N/A	N/A	N/A	N/A
Nevada	Las Vegas	2,521	1.11	277	2,798
North Carolina	Charlotte	N/A	N/A	N/A	N/A
North Dakota	Bismarck	N/A	N/A	N/A	N/A
Oklahoma	Oklahoma City	N/A	N/A	N/A	N/A
Oklahoma	Tulsa	N/A	N/A	N/A	N/A
Ohio	Cincinnati	N/A	N/A	N/A	N/A
Oregon	Portland	2,521	1.07	183	2,704
Pennsylvania	Philadelphia	N/A	N/A	N/A	N/A
Pennsylvania	Wilkes-Barre	N/A	N/A	N/A	N/A
Rhode Island	Providence	N/A	N/A	N/A	N/A
South Carolina	Charleston	N/A	N/A	N/A	N/A
South Carolina	Spartanburg (Asheville, NC)	N/A	N/A	N/A	N/A
South Dakota	Rapid City	N/A	N/A	N/A	N/A
Tennessee	Knoxville (Nashville)	N/A	N/A	N/A	N/A
Texas	Houston	N/A	N/A	N/A	N/A
Utah	Salt Lake City	N/A	N/A	N/A	N/A
Vermont	Burlington	N/A	N/A	N/A	N/A
Virginia	Alexandria	N/A	N/A	N/A	N/A
Virginia	Lynchburg	N/A	N/A	N/A	N/A
Washington	Seattle	2,521	1.11	276	2,797
Washington	Spokane	2,521	1.04	89	2,610
West Virginia	Charleston	N/A	N/A	N/A	N/A
Wisconsin	Green Bay	N/A	N/A	N/A	N/A
Wyoming	Cheyenne	N/A	N/A	N/A	N/A

**Table 1 16 — Location Adjustment for 30-MW Internal Combustion Engines (4 x 9.1MW)**  
**(2019 Dollars)**  
**Case Configuration: 1100 MW, H-Class, 2x2x1**

State	City	Base Project Cost (\$/kW )	Location Variation	Delta Cost Difference (\$/kW)	Total Location Project Cost (\$/kW)
Alabama	Huntsville	1,563	0.98	(39)	1,525
Arizona	Phoenix	1,563	0.98	(28)	1,536
Arkansas	Little Rock	1,563	0.99	(23)	1,540
California	Bakersfield	1,563	1.16	249	1,812
California	Los Angeles	1,563	1.16	258	1,821
California	Modesto (instead of Redding)	1,563	1.16	248	1,812
California	Sacramento	1,563	1.17	267	1,831
California	San Francisco	1,563	1.25	394	1,957
Colorado	Denver	1,563	0.97	(49)	1,515
Connecticut	Hartford	1,563	1.14	213	1,776
Delaware	Dover	1,563	1.09	146	1,709
District of Columbia	Washington	1,563	1.02	36	1,599
Florida	Tallahassee	1,563	0.96	(67)	1,497
Florida	Tampa	1,563	0.97	(50)	1,513
Georgia	Atlanta	1,563	0.99	(12)	1,551
Idaho	Boise	1,563	1.02	32	1,595
Illinois	Chicago	1,563	1.20	320	1,884
Illinois	Joliet	1,563	1.17	268	1,831
Indiana	Indianapolis	1,563	1.02	33	1,596
Iowa	Davenport	1,563	1.04	55	1,619
Iowa	Waterloo	1,563	0.98	(27)	1,536
Kansas	Wichita	1,563	0.99	(23)	1,540
Kentucky	Louisville	1,563	1.01	13	1,576
Louisiana	New Orleans	1,563	0.99	(20)	1,543
Maine	Portland	1,563	1.01	23	1,586
Maryland	Baltimore	1,563	1.02	31	1,594
Massachusetts	Boston	1,563	1.17	270	1,833
Michigan	Detroit	1,563	1.09	135	1,698
Michigan	Grand Rapids	1,563	1.02	36	1,599
Minnesota	Saint Paul	1,563	1.08	122	1,685
Mississippi	Jackson	1,563	0.96	(66)	1,497
Missouri	St. Louis	1,563	1.12	180	1,744
Missouri	Kansas City	1,563	1.06	99	1,663
Montana	Great Falls	1,563	0.98	(34)	1,530
Nebraska	Omaha	1,563	0.99	(20)	1,543
New Hampshire	Concord	1,563	1.06	101	1,664
New Jersey	Newark	1,563	1.18	288	1,851
New Mexico	Albuquerque	1,563	1.00	4	1,567
New York	New York	1,563	1.36	566	2,129
New York	Syracuse	1,563	1.05	81	1,644
Nevada	Las Vegas	1,563	1.12	191	1,755
North Carolina	Charlotte	1,563	0.97	(47)	1,517
North Dakota	Bismarck	1,563	1.00	5	1,568
Oklahoma	Oklahoma City	1,563	1.00	1	1,564
Oklahoma	Tulsa	1,563	0.95	(85)	1,479
Ohio	Cincinnati	1,563	0.95	(85)	1,478
Oregon	Portland	1,563	1.09	135	1,698
Pennsylvania	Philadelphia	1,563	1.18	274	1,838
Pennsylvania	Wilkes-Barre	1,563	1.06	91	1,654
Rhode Island	Providence	1,563	1.12	184	1,747
South Carolina	Charleston	1,563	1.00	(5)	1,558
South Carolina	Spartanburg (Asheville, NC)	1,563	0.98	(31)	1,532
South Dakota	Rapid City	1,563	0.98	(35)	1,528
Tennessee	Knoxville (Nashville)	1,563	0.99	(9)	1,554
Texas	Houston	1,563	0.94	(90)	1,473
Utah	Salt Lake City	1,563	1.00	3	1,567
Vermont	Burlington	1,563	1.06	86	1,650
Virginia	Alexandria	1,563	1.02	30	1,593
Virginia	Lynchburg	1,563	0.97	(48)	1,516
Washington	Seattle	1,563	1.13	198	1,761
Washington	Spokane	1,563	1.04	56	1,619
West Virginia	Charleston	1,563	1.03	46	1,609
Wisconsin	Green Bay	1,563	1.03	44	1,607
Wyoming	Cheyenne	1,563	0.99	(16)	1,547

**Table 1 17 — Location Adjustment for Hydroelectric (Representative Plant in New-Stream-Reach Location)**  
**(2019 Dollars)**  
**Case Configuration: 100 MW**

State	City	Base Project Cost (\$/kW )	Location Variation	Delta Cost Difference (\$/kW)	Total Location Project Cost (\$/kW)
Alabama	Huntsville	N/A	N/A	N/A	N/A
Arizona	Phoenix	N/A	N/A	N/A	N/A
Arkansas	Little Rock	N/A	N/A	N/A	N/A
California	Bakersfield	5,316	1.16	871	6,187
California	Los Angeles	5,316	1.12	659	5,975
California	Modesto (instead of Redding)	5,316	1.21	1,100	6,417
California	Sacramento	5,316	1.21	1,092	6,408
California	San Francisco	5,316	1.27	1,420	6,737
Colorado	Denver	5,316	1.02	94	5,410
Connecticut	Hartford	5,316	1.17	920	6,236
Delaware	Dover	N/A	N/A	N/A	N/A
District of Columbia	Washington	N/A	N/A	N/A	N/A
Florida	Tallahassee	N/A	N/A	N/A	N/A
Florida	Tampa	N/A	N/A	N/A	N/A
Georgia	Atlanta	N/A	N/A	N/A	N/A
Idaho	Boise	5,316	0.75	(1,345)	3,971
Illinois	Chicago	N/A	N/A	N/A	N/A
Illinois	Joliet	N/A	N/A	N/A	N/A
Indiana	Indianapolis	N/A	N/A	N/A	N/A
Iowa	Davenport	N/A	N/A	N/A	N/A
Iowa	Waterloo	N/A	N/A	N/A	N/A
Kansas	Wichita	N/A	N/A	N/A	N/A
Kentucky	Louisville	N/A	N/A	N/A	N/A
Louisiana	New Orleans	N/A	N/A	N/A	N/A
Maine	Portland	5,316	1.03	163	5,479
Maryland	Baltimore	N/A	N/A	N/A	N/A
Massachusetts	Boston	N/A	N/A	N/A	N/A
Michigan	Detroit	N/A	N/A	N/A	N/A
Michigan	Grand Rapids	N/A	N/A	N/A	N/A
Minnesota	Saint Paul	N/A	N/A	N/A	N/A
Mississippi	Jackson	N/A	N/A	N/A	N/A
Missouri	St. Louis	5,316	1.15	771	6,088
Missouri	Kansas City	5,316	1.06	332	5,648
Montana	Great Falls	5,316	0.97	(141)	5,175
Nebraska	Omaha	N/A	N/A	N/A	N/A
New Hampshire	Concord	N/A	N/A	N/A	N/A
New Jersey	Newark	N/A	N/A	N/A	N/A
New Mexico	Albuquerque	N/A	N/A	N/A	N/A
New York	New York	N/A	N/A	N/A	N/A
New York	Syracuse	N/A	N/A	N/A	N/A
Nevada	Las Vegas	N/A	N/A	N/A	N/A
North Carolina	Charlotte	5,316	0.97	(161)	5,155
North Dakota	Bismarck	N/A	N/A	N/A	N/A
Oklahoma	Oklahoma City	N/A	N/A	N/A	N/A
Oklahoma	Tulsa	N/A	N/A	N/A	N/A
Ohio	Cincinnati	5,316	0.94	(318)	4,998
Oregon	Portland	5,316	1.11	565	5,881
Pennsylvania	Philadelphia	N/A	N/A	N/A	N/A
Pennsylvania	Wilkes-Barre	N/A	N/A	N/A	N/A
Rhode Island	Providence	N/A	N/A	N/A	N/A
South Carolina	Charleston	N/A	N/A	N/A	N/A
South Carolina	Spartanburg (Asheville, NC)	N/A	N/A	N/A	N/A
South Dakota	Rapid City	5,316	0.96	(198)	5,119
Tennessee	Knoxville (Nashville)	N/A	N/A	N/A	N/A
Texas	Houston	N/A	N/A	N/A	N/A
Utah	Salt Lake City	N/A	N/A	N/A	N/A
Vermont	Burlington	N/A	N/A	N/A	N/A
Virginia	Alexandria	N/A	N/A	N/A	N/A
Virginia	Lynchburg	N/A	N/A	N/A	N/A
Washington	Seattle	5,316	1.15	780	6,096
Washington	Spokane	5,316	1.06	329	5,645
West Virginia	Charleston	N/A	N/A	N/A	N/A
Wisconsin	Green Bay	N/A	N/A	N/A	N/A
Wyoming	Cheyenne	N/A	N/A	N/A	N/A



**Table 1 18 — Location Adjustment for Battery Storage: 4 Hours**  
**A battery energy storage project designed primarily to provide resource adequacy and bulk energy storage.**  
**(2019 Dollars)**  
**Case Configuration: 50 MW / 200 MWh**

State	City	Base Project Cost (\$/kW )	Location Variation	Delta Cost Difference (\$/kW)	Total Location Project Cost (\$/kW)
Alabama	Huntsville	1,389	1.02	24	1,413
Arizona	Phoenix	1,389	0.99	(15)	1,374
Arkansas	Little Rock	1,389	1.04	56	1,445
California	Bakersfield	1,389	1.04	57	1,446
California	Los Angeles	1,389	1.04	60	1,449
California	Modesto (instead of Redding)	1,389	1.04	55	1,444
California	Sacramento	1,389	1.04	57	1,446
California	San Francisco	1,389	1.04	60	1,449
Colorado	Denver	1,389	0.99	(12)	1,377
Connecticut	Hartford	1,389	1.02	23	1,412
Delaware	Dover	1,389	0.99	(17)	1,373
District of Columbia	Washington	1,389	1.01	9	1,398
Florida	Tallahassee	1,389	1.00	0	1,389
Florida	Tampa	1,389	1.01	7	1,396
Georgia	Atlanta	1,389	1.02	25	1,414
Idaho	Boise	1,389	1.01	19	1,408
Illinois	Chicago	1,389	1.01	15	1,404
Illinois	Joliet	1,389	1.01	12	1,401
Indiana	Indianapolis	1,389	1.02	29	1,418
Iowa	Davenport	1,389	1.00	1	1,390
Iowa	Waterloo	1,389	1.00	(1)	1,388
Kansas	Wichita	1,389	1.00	(2)	1,387
Kentucky	Louisville	1,389	1.02	28	1,417
Louisiana	New Orleans	1,389	1.03	44	1,434
Maine	Portland	1,389	1.01	11	1,400
Maryland	Baltimore	1,389	1.01	8	1,397
Massachusetts	Boston	1,389	1.02	32	1,421
Michigan	Detroit	1,389	1.00	5	1,394
Michigan	Grand Rapids	1,389	1.00	0	1,390
Minnesota	Saint Paul	1,389	0.99	(21)	1,368
Mississippi	Jackson	1,389	1.00	(4)	1,385
Missouri	St. Louis	1,389	1.05	71	1,460
Missouri	Kansas City	1,389	1.00	5	1,394
Montana	Great Falls	1,389	0.99	(8)	1,381
Nebraska	Omaha	1,389	1.00	1	1,390
New Hampshire	Concord	1,389	1.03	47	1,436
New Jersey	Newark	1,389	1.02	23	1,412
New Mexico	Albuquerque	1,389	1.04	49	1,438
New York	New York	1,389	1.03	37	1,426
New York	Syracuse	1,389	1.00	5	1,394
Nevada	Las Vegas	1,389	1.04	56	1,445
North Carolina	Charlotte	1,389	1.00	(2)	1,387
North Dakota	Bismarck	1,389	0.98	(29)	1,360
Oklahoma	Oklahoma City	1,389	1.00	(6)	1,383
Oklahoma	Tulsa	1,389	0.99	(8)	1,381
Ohio	Cincinnati	1,389	0.99	(8)	1,381
Oregon	Portland	1,389	1.04	53	1,442
Pennsylvania	Philadelphia	1,389	1.02	22	1,411
Pennsylvania	Wilkes-Barre	1,389	1.01	8	1,397
Rhode Island	Providence	1,389	1.02	33	1,422
South Carolina	Charleston	1,389	1.08	114	1,503
South Carolina	Spartanburg (Asheville, NC)	1,389	1.02	22	1,411
South Dakota	Rapid City	1,389	0.98	(31)	1,358
Tennessee	Knoxville (Nashville)	1,389	1.04	57	1,446
Texas	Houston	1,389	1.00	0	1,389
Utah	Salt Lake City	1,389	1.04	54	1,443
Vermont	Burlington	1,389	1.08	109	1,498
Virginia	Alexandria	1,389	1.01	9	1,398
Virginia	Lynchburg	1,389	1.00	(4)	1,385
Washington	Seattle	1,389	1.04	61	1,450
Washington	Spokane	1,389	1.02	26	1,415
West Virginia	Charleston	1,389	1.00	(1)	1,389
Wisconsin	Green Bay	1,389	0.98	(33)	1,356
Wyoming	Cheyenne	1,389	0.99	(13)	1,376

**Table 1 19 — Location Adjustment for Battery Storage: 2 hours  
(2019 Dollars)  
Case Configuration: 50 MW / 100 MWh**

State	City	Base Project Cost (\$/kW )	Location Variation	Delta Cost Difference (\$/kW)	Total Location Project Cost (\$/kW)
Alabama	Huntsville	845	1.02	15	860
Arizona	Phoenix	845	0.99	(9)	836
Arkansas	Little Rock	845	1.04	34	879
California	Bakersfield	845	1.04	35	880
California	Los Angeles	845	1.04	36	881
California	Modesto (instead of Redding)	845	1.04	33	878
California	Sacramento	845	1.04	34	880
California	San Francisco	845	1.04	37	882
Colorado	Denver	845	0.99	(7)	838
Connecticut	Hartford	845	1.02	14	859
Delaware	Dover	845	0.99	(10)	835
District of Columbia	Washington	845	1.01	5	851
Florida	Tallahassee	845	1.00	0	845
Florida	Tampa	845	1.00	4	849
Georgia	Atlanta	845	1.02	15	860
Idaho	Boise	845	1.01	12	857
Illinois	Chicago	845	1.01	9	854
Illinois	Joliet	845	1.01	7	853
Indiana	Indianapolis	845	1.02	18	863
Iowa	Davenport	845	1.00	1	846
Iowa	Waterloo	845	1.00	(1)	844
Kansas	Wichita	845	1.00	(1)	844
Kentucky	Louisville	845	1.02	17	862
Louisiana	New Orleans	845	1.03	27	872
Maine	Portland	845	1.01	6	852
Maryland	Baltimore	845	1.01	5	850
Massachusetts	Boston	845	1.02	19	865
Michigan	Detroit	845	1.00	3	848
Michigan	Grand Rapids	845	1.00	0	845
Minnesota	Saint Paul	845	0.99	(13)	833
Mississippi	Jackson	845	1.00	(3)	843
Missouri	St. Louis	845	1.05	43	888
Missouri	Kansas City	845	1.00	3	848
Montana	Great Falls	845	0.99	(5)	840
Nebraska	Omaha	845	1.00	0	846
New Hampshire	Concord	845	1.03	28	874
New Jersey	Newark	845	1.02	14	859
New Mexico	Albuquerque	845	1.04	30	875
New York	New York	845	1.03	23	868
New York	Syracuse	845	1.00	3	848
Nevada	Las Vegas	845	1.04	34	879
North Carolina	Charlotte	845	1.00	(1)	844
North Dakota	Bismarck	845	0.98	(18)	827
Oklahoma	Oklahoma City	845	1.00	(4)	841
Oklahoma	Tulsa	845	0.99	(5)	840
Ohio	Cincinnati	845	0.99	(5)	840
Oregon	Portland	845	1.04	32	877
Pennsylvania	Philadelphia	845	1.02	14	859
Pennsylvania	Wilkes-Barre	845	1.01	5	850
Rhode Island	Providence	845	1.02	20	865
South Carolina	Charleston	845	1.08	69	914
South Carolina	Spartanburg (Asheville, NC)	845	1.02	13	859
South Dakota	Rapid City	845	0.98	(19)	826
Tennessee	Knoxville (Nashville)	845	1.04	34	879
Texas	Houston	845	1.00	0	845
Utah	Salt Lake City	845	1.04	33	878
Vermont	Burlington	845	1.08	66	911
Virginia	Alexandria	845	1.01	5	850
Virginia	Lynchburg	845	1.00	(2)	843
Washington	Seattle	845	1.04	37	882
Washington	Spokane	845	1.02	16	861
West Virginia	Charleston	845	1.00	0	845
Wisconsin	Green Bay	845	0.98	(20)	825
Wyoming	Cheyenne	845	0.99	(7)	839

**Table 1 20 — Location Adjustment for Onshore Wind, Large Plant Footprint: Great Plains Region  
(2019 Dollars)  
Case Configuration: 200 MW, 2.8-MW WTG**

State	City	Base Project Cost (\$/kW )	Location Variation	Delta Cost Difference (\$/kW)	Total Location Project Cost (\$/kW)
Alabama	Huntsville	1,265	1.01	12	1,277
Arizona	Phoenix	1,265	0.99	(16)	1,249
Arkansas	Little Rock	1,265	1.03	35	1,301
California	Bakersfield	1,265	1.05	60	1,325
California	Los Angeles	1,265	1.05	63	1,329
California	Modesto (instead of Redding)	1,265	1.05	58	1,323
California	Sacramento	1,265	1.05	62	1,327
California	San Francisco	1,265	1.06	76	1,342
Colorado	Denver	1,265	0.99	(13)	1,252
Connecticut	Hartford	1,265	1.03	32	1,298
Delaware	Dover	1,265	1.00	(1)	1,265
District of Columbia	Washington	1,265	1.01	9	1,274
Florida	Tallahassee	1,265	1.00	(6)	1,259
Florida	Tampa	1,265	1.00	0	1,265
Georgia	Atlanta	1,265	1.01	14	1,280
Idaho	Boise	1,265	1.01	16	1,281
Illinois	Chicago	1,265	1.03	37	1,302
Illinois	Joliet	1,265	1.03	32	1,297
Indiana	Indianapolis	1,265	1.02	23	1,288
Iowa	Davenport	1,265	1.00	4	1,269
Iowa	Waterloo	1,265	0.99	(7)	1,259
Kansas	Wichita	1,265	1.00	(6)	1,259
Kentucky	Louisville	1,265	1.01	19	1,284
Louisiana	New Orleans	1,265	1.02	28	1,293
Maine	Portland	1,265	1.01	8	1,274
Maryland	Baltimore	1,265	1.01	7	1,272
Massachusetts	Boston	1,265	1.04	46	1,311
Michigan	Detroit	1,265	1.01	15	1,281
Michigan	Grand Rapids	1,265	1.00	3	1,268
Minnesota	Saint Paul	1,265	1.00	(5)	1,261
Mississippi	Jackson	1,265	0.99	(9)	1,256
Missouri	St. Louis	1,265	1.05	63	1,328
Missouri	Kansas City	1,265	1.01	12	1,277
Montana	Great Falls	1,265	0.99	(9)	1,256
Nebraska	Omaha	1,265	1.00	(3)	1,263
New Hampshire	Concord	1,265	1.03	38	1,304
New Jersey	Newark	1,265	1.03	42	1,307
New Mexico	Albuquerque	1,265	1.03	33	1,298
New York	New York	1,265	1.06	74	1,339
New York	Syracuse	1,265	1.01	11	1,277
Nevada	Las Vegas	1,265	1.04	55	1,320
North Carolina	Charlotte	1,265	1.00	(6)	1,259
North Dakota	Bismarck	1,265	0.98	(21)	1,245
Oklahoma	Oklahoma City	1,265	1.00	(5)	1,260
Oklahoma	Tulsa	1,265	0.99	(13)	1,252
Ohio	Cincinnati	1,265	0.99	(13)	1,252
Oregon	Portland	1,265	1.04	47	1,312
Pennsylvania	Philadelphia	1,265	1.03	41	1,306
Pennsylvania	Wilkes-Barre	1,265	1.01	11	1,276
Rhode Island	Providence	1,265	1.03	37	1,302
South Carolina	Charleston	1,265	1.06	76	1,342
South Carolina	Spartanburg (Asheville, NC)	1,265	1.01	11	1,277
South Dakota	Rapid City	1,265	0.98	(25)	1,240
Tennessee	Knoxville (Nashville)	1,265	1.03	36	1,301
Texas	Houston	1,265	0.99	(8)	1,257
Utah	Salt Lake City	1,265	1.03	34	1,300
Vermont	Burlington	1,265	1.06	79	1,345
Virginia	Alexandria	1,265	1.01	8	1,273
Virginia	Lynchburg	1,265	0.99	(9)	1,257
Washington	Seattle	1,265	1.05	57	1,323
Washington	Spokane	1,265	1.02	21	1,286
West Virginia	Charleston	1,265	1.00	4	1,269
Wisconsin	Green Bay	1,265	0.99	(19)	1,247
Wyoming	Cheyenne	1,265	0.99	(10)	1,255

**Table 1 21 — Location Adjustment for Onshore Wind, Small Plant Footprint: Coastal Region  
(2019 Dollars)  
Case Configuration: 50 MW, 2.8-MW WTG**

State	City	Base Project Cost (\$/kW )	Location Variation	Delta Cost Difference (\$/kW)	Total Location Project Cost (\$/kW)
Alabama	Huntsville	1,677	1.01	14	1,691
Arizona	Phoenix	1,677	0.99	(23)	1,653
Arkansas	Little Rock	1,677	1.03	46	1,722
California	Bakersfield	1,677	1.05	89	1,765
California	Los Angeles	1,677	1.06	94	1,770
California	Modesto (instead of Redding)	1,677	1.05	86	1,762
California	Sacramento	1,677	1.05	91	1,768
California	San Francisco	1,677	1.07	116	1,793
Colorado	Denver	1,677	0.99	(19)	1,658
Connecticut	Hartford	1,677	1.03	50	1,727
Delaware	Dover	1,677	1.00	4	1,680
District of Columbia	Washington	1,677	1.01	13	1,689
Florida	Tallahassee	1,677	0.99	(11)	1,666
Florida	Tampa	1,677	1.00	(3)	1,674
Georgia	Atlanta	1,677	1.01	18	1,695
Idaho	Boise	1,677	1.01	22	1,699
Illinois	Chicago	1,677	1.04	61	1,737
Illinois	Joliet	1,677	1.03	53	1,729
Indiana	Indianapolis	1,677	1.02	32	1,709
Iowa	Davenport	1,677	1.00	7	1,683
Iowa	Waterloo	1,677	0.99	(11)	1,666
Kansas	Wichita	1,677	0.99	(10)	1,667
Kentucky	Louisville	1,677	1.02	25	1,702
Louisiana	New Orleans	1,677	1.02	36	1,712
Maine	Portland	1,677	1.01	11	1,688
Maryland	Baltimore	1,677	1.01	10	1,686
Massachusetts	Boston	1,677	1.04	71	1,747
Michigan	Detroit	1,677	1.02	25	1,702
Michigan	Grand Rapids	1,677	1.00	5	1,681
Minnesota	Saint Paul	1,677	1.00	(2)	1,674
Mississippi	Jackson	1,677	0.99	(15)	1,662
Missouri	St. Louis	1,677	1.05	90	1,767
Missouri	Kansas City	1,677	1.01	19	1,695
Montana	Great Falls	1,677	0.99	(14)	1,663
Nebraska	Omaha	1,677	1.00	(5)	1,672
New Hampshire	Concord	1,677	1.03	54	1,731
New Jersey	Newark	1,677	1.04	67	1,743
New Mexico	Albuquerque	1,677	1.03	44	1,720
New York	New York	1,677	1.07	118	1,795
New York	Syracuse	1,677	1.01	18	1,695
Nevada	Las Vegas	1,677	1.05	80	1,756
North Carolina	Charlotte	1,677	0.99	(10)	1,666
North Dakota	Bismarck	1,677	0.98	(27)	1,649
Oklahoma	Oklahoma City	1,677	1.00	(7)	1,670
Oklahoma	Tulsa	1,677	0.99	(21)	1,656
Ohio	Cincinnati	1,677	0.99	(21)	1,655
Oregon	Portland	1,677	1.04	67	1,744
Pennsylvania	Philadelphia	1,677	1.04	65	1,742
Pennsylvania	Wilkes-Barre	1,677	1.01	17	1,694
Rhode Island	Providence	1,677	1.03	55	1,732
South Carolina	Charleston	1,677	1.06	101	1,778
South Carolina	Spartanburg (Asheville, NC)	1,677	1.01	14	1,690
South Dakota	Rapid City	1,677	0.98	(35)	1,642
Tennessee	Knoxville (Nashville)	1,677	1.03	46	1,723
Texas	Houston	1,677	0.99	(14)	1,662
Utah	Salt Lake City	1,677	1.03	45	1,722
Vermont	Burlington	1,677	1.06	108	1,785
Virginia	Alexandria	1,677	1.01	11	1,688
Virginia	Lynchburg	1,677	0.99	(14)	1,663
Washington	Seattle	1,677	1.05	83	1,760
Washington	Spokane	1,677	1.02	29	1,705
West Virginia	Charleston	1,677	1.00	6	1,683
Wisconsin	Green Bay	1,677	0.99	(24)	1,653
Wyoming	Cheyenne	1,677	0.99	(15)	1,662

**Table 1-22 — Location Adjustment for Offshore Wind  
(2019 Dollars)  
Case Configuration: 40 x 10 MW WTG**

State	City	Base Project Cost (\$/kW )	Location Variation	Delta Cost Difference (\$/kW)	Total Location Project Cost (\$/kW)
Alabama	Huntsville	N/A	N/A	N/A	N/A
Arizona	Phoenix	N/A	N/A	N/A	N/A
Arkansas	Little Rock	N/A	N/A	N/A	N/A
California	Bakersfield	4,375	1.03	152	4,527
California	Los Angeles	4,375	1.58	2,548	6,923
California	Modesto (instead of Redding)	4,375	1.52	2,264	6,639
California	Sacramento	4,375	1.58	2,538	6,912
California	San Francisco	4,375	1.90	3,944	8,318
Colorado	Denver	N/A	N/A	N/A	N/A
Connecticut	Hartford	4,375	1.01	41	4,416
Delaware	Dover	4,375	1.31	1,344	5,719
District of Columbia	Washington	N/A	N/A	N/A	N/A
Florida	Tallahassee	N/A	N/A	N/A	N/A
Florida	Tampa	N/A	N/A	N/A	N/A
Georgia	Atlanta	4,375	1.02	87	4,462
Idaho	Boise	N/A	N/A	N/A	N/A
Illinois	Chicago	4,375	1.00	(7)	4,368
Illinois	Joliet	4,375	1.65	2,842	7,217
Indiana	Indianapolis	4,375	1.06	277	4,652
Iowa	Davenport	N/A	N/A	N/A	N/A
Iowa	Waterloo	N/A	N/A	N/A	N/A
Kansas	Wichita	N/A	N/A	N/A	N/A
Kentucky	Louisville	N/A	N/A	N/A	N/A
Louisiana	New Orleans	N/A	N/A	N/A	N/A
Maine	Portland	4,375	1.01	31	4,405
Maryland	Baltimore	4,375	1.04	180	4,555
Massachusetts	Boston	4,375	1.64	2,815	7,190
Michigan	Detroit	4,375	1.32	1,409	5,784
Michigan	Grand Rapids	4,375	1.07	318	4,693
Minnesota	Saint Paul	4,375	1.29	1,286	5,661
Mississippi	Jackson	N/A	N/A	N/A	N/A
Missouri	St. Louis	N/A	N/A	N/A	N/A
Missouri	Kansas City	N/A	N/A	N/A	N/A
Montana	Great Falls	N/A	N/A	N/A	N/A
Nebraska	Omaha	N/A	N/A	N/A	N/A
New Hampshire	Concord	N/A	N/A	N/A	N/A
New Jersey	Newark	4,375	1.01	27	4,402
New Mexico	Albuquerque	N/A	N/A	N/A	N/A
New York	New York	4,375	1.01	27	4,402
New York	Syracuse	4,375	1.22	962	5,337
Nevada	Las Vegas	N/A	N/A	N/A	N/A
North Carolina	Charlotte	4,375	1.00	0	4,375
North Dakota	Bismarck	N/A	N/A	N/A	N/A
Oklahoma	Oklahoma City	N/A	N/A	N/A	N/A
Oklahoma	Tulsa	N/A	N/A	N/A	N/A
Ohio	Cincinnati	N/A	N/A	N/A	N/A
Oregon	Portland	4,375	1.00	(12)	4,363
Pennsylvania	Philadelphia	N/A	N/A	N/A	N/A
Pennsylvania	Wilkes-Barre	N/A	N/A	N/A	N/A
Rhode Island	Providence	4,375	1.01	27	4,402
South Carolina	Charleston	4,375	0.81	(819)	3,556
South Carolina	Spartanburg (Asheville, NC)	4,375	0.89	(494)	3,881
South Dakota	Rapid City	N/A	N/A	N/A	N/A
Tennessee	Knoxville (Nashville)	N/A	N/A	N/A	N/A
Texas	Houston	4,375	0.98	(102)	4,273
Utah	Salt Lake City	N/A	N/A	N/A	N/A
Vermont	Burlington	N/A	N/A	N/A	N/A
Virginia	Alexandria	4,375	1.04	182	4,557
Virginia	Lynchburg	4,375	0.91	(375)	4,000
Washington	Seattle	4,375	1.35	1,531	5,905
Washington	Spokane	4,375	1.05	209	4,584
West Virginia	Charleston	N/A	N/A	N/A	N/A
Wisconsin	Green Bay	4,375	1.02	81	4,455
Wyoming	Cheyenne	N/A	N/A	N/A	N/A

**Table 1 23 — Location Adjustment for Concentrated Solar Thermal Plant (CSP), Power Tower, 8-hour Thermal Storage  
(2019 Dollars)  
Case Configuration: 100 MW**

State	City	Base Project Cost (\$/kW )	Location Variation	Delta Cost Difference (\$/kW)	Total Location Project Cost (\$/kW)
Alabama	Huntsville	7221	1.01	67	7288
Arizona	Phoenix	7221	0.97	(201)	7021
Arkansas	Little Rock	7221	1.05	370	7591
California	Bakersfield	7221	1.17	1,220	8441
California	Los Angeles	7221	1.18	1,269	8490
California	Modesto (instead of Redding)	7221	1.17	1,242	8463
California	Sacramento	7221	1.18	1,307	8529
California	San Francisco	7221	1.24	1,738	8959
Colorado	Denver	7221	0.97	(241)	6980
Connecticut	Hartford	7221	1.11	782	8003
Delaware	Dover	7221	1.05	346	7568
District of Columbia	Washington	7221	1.02	144	7365
Florida	Tallahassee	7221	0.97	(212)	7009
Florida	Tampa	7221	0.99	(88)	7134
Georgia	Atlanta	7221	1.02	151	7372
Idaho	Boise	7221	1.03	247	7468
Illinois	Chicago	7221	1.14	1,030	8252
Illinois	Joliet	7221	1.12	881	8102
Indiana	Indianapolis	7221	1.04	305	7527
Iowa	Davenport	7221	1.02	144	7365
Iowa	Waterloo	7221	0.98	(129)	7092
Kansas	Wichita	7221	0.98	(138)	7083
Kentucky	Louisville	7221	1.04	256	7477
Louisiana	New Orleans	7221	1.04	275	7496
Maine	Portland	7221	1.02	138	7359
Maryland	Baltimore	7221	1.02	128	7350
Massachusetts	Boston	7221	1.14	1,040	8261
Michigan	Detroit	7221	1.07	470	7692
Michigan	Grand Rapids	7221	1.02	132	7353
Minnesota	Saint Paul	7221	1.02	128	7350
Mississippi	Jackson	7221	0.97	(244)	6978
Missouri	St. Louis	7221	1.16	1,126	8347
Missouri	Kansas City	7221	1.04	313	7535
Montana	Great Falls	7221	0.97	(206)	7015
Nebraska	Omaha	7221	0.99	(105)	7117
New Hampshire	Concord	7221	1.09	666	7888
New Jersey	Newark	7221	1.14	1,027	8248
New Mexico	Albuquerque	7221	1.05	355	7577
New York	New York	7221	1.27	1,982	9203
New York	Syracuse	7221	1.04	255	7477
Nevada	Las Vegas	7221	1.14	1,033	8254
North Carolina	Charlotte	7221	0.98	(175)	7046
North Dakota	Bismarck	7221	0.98	(180)	7041
Oklahoma	Oklahoma City	7221	0.99	(38)	7184
Oklahoma	Tulsa	7221	0.95	(332)	6889
Ohio	Cincinnati	7221	0.95	(333)	6888
Oregon	Portland	7221	1.11	829	8050
Pennsylvania	Philadelphia	7221	1.14	986	8207
Pennsylvania	Wilkes-Barre	7221	1.05	326	7548
Rhode Island	Providence	7221	1.11	791	8012
South Carolina	Charleston	7221	1.12	865	8086
South Carolina	Spartanburg (Asheville, NC)	7221	1.01	58	7280
South Dakota	Rapid City	7221	0.94	(409)	6812
Tennessee	Knoxville (Nashville)	7221	1.06	452	7673
Texas	Houston	7221	0.96	(255)	6966
Utah	Salt Lake City	7221	1.06	408	7630
Vermont	Burlington	7221	1.16	1,174	8396
Virginia	Alexandria	7221	1.02	114	7335
Virginia	Lynchburg	7221	0.97	(196)	7025
Washington	Seattle	7221	1.16	1,124	8345
Washington	Spokane	7221	1.06	442	7664
West Virginia	Charleston	7221	1.02	140	7361
Wisconsin	Green Bay	7221	0.98	(167)	7054
Wyoming	Cheyenne	7221	0.98	(174)	7048

**Note:** Location adjustment factors are provided for all locations for the Concentrated Solar Power case. However, concentrated solar power is only feasible in locations with sufficient solar resource; therefore, it is unlikely that a concentrated solar power plant would be built in some of the locations for which factors are provided.

**Table 1 24 — Location Adjustment for Solar Photovoltaic, Single-Axis Tracking (with 1.3 Inverter Loading Ratio)**  
**(2019 Dollars)**  
**Case Configuration: 150 MW**

State	City	Base Project Cost (\$/kW )	Location Variation	Delta Cost Difference (\$/kW)	Total Location Project Cost (\$/kW)
Alabama	Huntsville	1,313	0.95	(68)	1,244
Arizona	Phoenix	1,313	0.97	(40)	1,273
Arkansas	Little Rock	1,313	0.98	(29)	1,284
California	Bakersfield	1,313	1.07	87	1,400
California	Los Angeles	1,313	1.09	116	1,429
California	Modesto (instead of Redding)	1,313	1.06	74	1,386
California	Sacramento	1,313	1.08	99	1,412
California	San Francisco	1,313	1.18	235	1,548
Colorado	Denver	1,313	0.98	(28)	1,285
Connecticut	Hartford	1,313	1.08	104	1,417
Delaware	Dover	1,313	1.04	56	1,369
District of Columbia	Washington	1,313	1.02	24	1,337
Florida	Tallahassee	1,313	0.96	(50)	1,263
Florida	Tampa	1,313	0.97	(37)	1,276
Georgia	Atlanta	1,313	0.98	(24)	1,289
Idaho	Boise	1,313	0.98	(32)	1,281
Illinois	Chicago	1,313	1.08	108	1,421
Illinois	Joliet	1,313	1.09	124	1,437
Indiana	Indianapolis	1,313	1.01	15	1,328
Iowa	Davenport	1,313	1.01	20	1,333
Iowa	Waterloo	1,313	0.97	(40)	1,273
Kansas	Wichita	1,313	0.98	(27)	1,286
Kentucky	Louisville	1,313	0.99	(8)	1,305
Louisiana	New Orleans	1,313	0.98	(27)	1,286
Maine	Portland	1,313	1.00	4	1,317
Maryland	Baltimore	1,313	1.01	13	1,326
Massachusetts	Boston	1,313	1.10	137	1,450
Michigan	Detroit	1,313	1.04	55	1,368
Michigan	Grand Rapids	1,313	1.01	13	1,326
Minnesota	Saint Paul	1,313	1.04	55	1,368
Mississippi	Jackson	1,313	0.97	(41)	1,272
Missouri	St. Louis	1,313	1.06	83	1,396
Missouri	Kansas City	1,313	1.03	38	1,351
Montana	Great Falls	1,313	0.98	(25)	1,288
Nebraska	Omaha	1,313	0.98	(21)	1,292
New Hampshire	Concord	1,313	1.02	20	1,333
New Jersey	Newark	1,313	1.11	151	1,464
New Mexico	Albuquerque	1,313	1.00	(5)	1,308
New York	New York	1,313	1.22	287	1,600
New York	Syracuse	1,313	1.03	34	1,347
Nevada	Las Vegas	1,313	1.07	87	1,399
North Carolina	Charlotte	1,313	0.97	(38)	1,274
North Dakota	Bismarck	1,313	0.99	(17)	1,296
Oklahoma	Oklahoma City	1,313	0.98	(29)	1,284
Oklahoma	Tulsa	1,313	0.95	(60)	1,253
Ohio	Cincinnati	1,313	0.95	(61)	1,252
Oregon	Portland	1,313	1.05	65	1,378
Pennsylvania	Philadelphia	1,313	1.13	173	1,486
Pennsylvania	Wilkes-Barre	1,313	1.02	24	1,337
Rhode Island	Providence	1,313	1.04	55	1,368
South Carolina	Charleston	1,313	1.03	44	1,357
South Carolina	Spartanburg (Asheville, NC)	1,313	1.04	55	1,368
South Dakota	Rapid City	1,313	0.96	(50)	1,263
Tennessee	Knoxville (Nashville)	1,313	1.00	(1)	1,312
Texas	Houston	1,313	0.99	(19)	1,294
Utah	Salt Lake City	1,313	0.97	(41)	1,272
Vermont	Burlington	1,313	0.97	(40)	1,273
Virginia	Alexandria	1,313	1.00	(6)	1,307
Virginia	Lynchburg	1,313	0.98	(25)	1,288
Washington	Seattle	1,313	1.03	41	1,354
Washington	Spokane	1,313	0.97	(43)	1,269
West Virginia	Charleston	1,313	1.06	77	1,390
Wisconsin	Green Bay	1,313	0.99	(16)	1,297
Wyoming	Cheyenne	1,313	1.01	13	1,326

**Table 1 25 — Location Adjustment for Solar Photovoltaic, Single-Axis Tracking (with 1.3 Inverter Loading Ratio) with Battery Hybrid  
(2019 Dollars)**

**Case Configuration: PV with tracking150 MW PV50 MW/200 MWh BESS**

State	City	Base Project Cost (\$/kW )	Location Variation	Delta Cost Difference (\$/kW)	Total Location Project Cost (\$/kW)
Alabama	Huntsville	1,755	0.98	(42)	1,713
Arizona	Phoenix	1,755	0.98	(36)	1,719
Arkansas	Little Rock	1,755	0.99	(11)	1,744
California	Bakersfield	1,755	1.07	129	1,884
California	Los Angeles	1,755	1.09	151	1,906
California	Modesto (instead of Redding)	1,755	1.07	116	1,871
California	Sacramento	1,755	1.08	137	1,892
California	San Francisco	1,755	1.14	243	1,998
Colorado	Denver	1,755	0.98	(32)	1,723
Connecticut	Hartford	1,755	1.07	125	1,881
Delaware	Dover	1,755	1.04	64	1,819
District of Columbia	Washington	1,755	1.02	29	1,785
Florida	Tallahassee	1,755	0.97	(45)	1,710
Florida	Tampa	1,755	0.98	(31)	1,724
Georgia	Atlanta	1,755	0.99	(11)	1,744
Idaho	Boise	1,755	1.00	(3)	1,753
Illinois	Chicago	1,755	1.09	162	1,918
Illinois	Joliet	1,755	1.09	152	1,908
Indiana	Indianapolis	1,755	1.01	26	1,781
Iowa	Davenport	1,755	1.02	28	1,783
Iowa	Waterloo	1,755	0.98	(32)	1,723
Kansas	Wichita	1,755	0.99	(18)	1,737
Kentucky	Louisville	1,755	1.00	5	1,760
Louisiana	New Orleans	1,755	0.99	(10)	1,745
Maine	Portland	1,755	1.01	14	1,769
Maryland	Baltimore	1,755	1.01	18	1,773
Massachusetts	Boston	1,755	1.09	164	1,919
Michigan	Detroit	1,755	1.04	68	1,824
Michigan	Grand Rapids	1,755	1.01	19	1,775
Minnesota	Saint Paul	1,755	1.04	68	1,823
Mississippi	Jackson	1,755	0.98	(41)	1,714
Missouri	St. Louis	1,755	1.06	114	1,869
Missouri	Kansas City	1,755	1.03	53	1,808
Montana	Great Falls	1,755	0.99	(23)	1,732
Nebraska	Omaha	1,755	0.99	(16)	1,740
New Hampshire	Concord	1,755	1.03	47	1,802
New Jersey	Newark	1,755	1.10	173	1,928
New Mexico	Albuquerque	1,755	1.01	12	1,768
New York	New York	1,755	1.19	332	2,087
New York	Syracuse	1,755	1.03	48	1,803
Nevada	Las Vegas	1,755	1.07	118	1,873
North Carolina	Charlotte	1,755	0.98	(33)	1,722
North Dakota	Bismarck	1,755	0.99	(11)	1,744
Oklahoma	Oklahoma City	1,755	0.99	(18)	1,737
Oklahoma	Tulsa	1,755	0.97	(59)	1,696
Ohio	Cincinnati	1,755	0.97	(60)	1,696
Oregon	Portland	1,755	1.05	84	1,839
Pennsylvania	Philadelphia	1,755	1.10	181	1,937
Pennsylvania	Wilkes-Barre	1,755	1.02	42	1,797
Rhode Island	Providence	1,755	1.05	93	1,848
South Carolina	Charleston	1,755	1.01	13	1,768
South Carolina	Spartanburg (Asheville, NC)	1,755	1.00	(7)	1,748
South Dakota	Rapid City	1,755	0.99	(26)	1,729
Tennessee	Knoxville (Nashville)	1,755	0.99	(16)	1,739
Texas	Houston	1,755	0.97	(56)	1,699
Utah	Salt Lake City	1,755	1.01	16	1,771
Vermont	Burlington	1,755	1.02	43	1,798
Virginia	Alexandria	1,755	1.02	33	1,788
Virginia	Lynchburg	1,755	0.98	(43)	1,712
Washington	Seattle	1,755	1.06	114	1,869
Washington	Spokane	1,755	1.01	17	1,772
West Virginia	Charleston	1,755	1.01	21	1,776
Wisconsin	Green Bay	1,755	1.01	12	1,767
Wyoming	Cheyenne	1,755	1.00	(6)	1,749





---

## **Appendix B. Combustion Turbine Capacity Adjustments**

---

# Performance Adjustment Factors

## **Capital Cost Study** *Cost and Performance Estimates for New Utility-Scale Electric Power Generating Technologies*

**Prepared by**  
Sargent & Lundy



**Prepared for**  
U.S. Energy Information  
Administration



**FINAL**

Contract No. 89303019CEI00022  
Project No. 13651-005

LOCATION		Adjustment Basis			Simple Cycle		Combined Cycle		Gas Turbine Based Capacity and Heat Rate Adjustments											
State	City	ASHRAE Station	Alt (ft)	Ave T (F)	MW Adj SC	HR Adj SC	MW Adj CC	HR Adj CC	2 x LM6000PF+		1 x 7F.05		1 x 7HA.01 WCT		1 x 7HA.01 ACC		2 x 7HA.02 WCT		2 x 7HA.02 ACC	
ISO	ISO	-	0	59.0	100.0%	100.0%	100.0%	100.0%	MW Net	HR Net	MW Net	HR Net	MW Net	HR Net	MW Net	HR Net	MW Net	HR Net	MW Net	HR Net
Alabama	Huntsville	723230	624	61.7	96.8%	100.3%	97.2%	100.3%	101.7	8,242	225.1	8,947	406.4	5,809	395.3	5,971	1,052.5	5,754	997.4	6,072
Alaska	Anchorage	997381	10	37.4	108.6%	97.8%	105.4%	98.9%	114.1	8,042	252.6	8,730	440.7	5,731	428.7	5,891	1,141.4	5,677	1,081.6	5,991
Alaska	Fairbanks	702610	432	28.0	110.7%	96.9%	106.1%	98.5%	116.3	7,965	257.5	8,646	443.9	5,709	431.8	5,868	1,149.6	5,655	1,089.4	5,967
Arizona	Phoenix	722780	1,107	75.2	89.9%	101.6%	92.2%	101.0%	94.5	8,353	209.1	9,068	385.8	5,853	375.3	6,017	999.1	5,798	946.8	6,118
Arkansas	Little Rock	723400	563	61.6	97.0%	100.3%	97.4%	100.2%	101.9	8,241	225.7	8,946	407.4	5,808	396.3	5,970	1,055.0	5,753	999.8	6,071
California	Los Angeles	722950	97	63.2	98.0%	100.4%	98.6%	100.2%	103.0	8,254	227.9	8,961	412.5	5,807	401.3	5,969	1,068.3	5,752	1,012.3	6,070
California	Redding	725920	497	62.8	96.8%	100.4%	97.3%	100.3%	101.7	8,251	225.1	8,957	407.1	5,810	396.0	5,973	1,054.3	5,755	999.1	6,073
California	Bakersfield	723840	489	65.7	95.7%	100.7%	96.6%	100.4%	100.5	8,275	222.5	8,983	404.2	5,819	393.2	5,981	1,046.9	5,764	992.1	6,082
California	Modesto	724926	73	63.0	98.1%	100.4%	98.7%	100.2%	103.1	8,253	228.3	8,959	413.0	5,806	401.8	5,968	1,069.7	5,751	1,013.7	6,069
California	Sacramento	724839	23	61.9	98.8%	100.3%	99.2%	100.1%	103.8	8,244	229.7	8,949	414.9	5,802	403.6	5,964	1,074.6	5,747	1,018.3	6,065
California	San Francisco	724940	8	58.1	100.3%	99.9%	100.2%	100.0%	105.4	8,212	233.4	8,915	419.1	5,791	407.7	5,953	1,085.4	5,736	1,028.6	6,053
Colorado	Denver	725650	5,414	51.0	83.6%	99.2%	82.7%	100.7%	87.9	8,154	194.6	8,852	345.8	5,833	336.4	5,996	895.6	5,778	848.7	6,097
Connecticut	Hartford	725087	19	52.3	102.6%	99.3%	101.6%	99.7%	107.8	8,165	238.7	8,863	425.0	5,774	413.4	5,936	1,100.7	5,720	1,043.0	6,036
DC	Washington	745940	282	56.4	100.0%	99.7%	99.7%	99.9%	105.1	8,199	232.7	8,900	416.8	5,789	405.5	5,951	1,079.6	5,735	1,023.0	6,051
Delaware	Dover	724088	28	56.1	101.1%	99.7%	100.6%	99.9%	106.2	8,196	235.1	8,897	420.9	5,785	409.4	5,947	1,090.1	5,731	1,033.0	6,047
Florida	Tallahassee	722140	55	68.2	96.1%	100.9%	97.5%	100.5%	101.0	8,295	223.6	9,005	407.9	5,821	396.8	5,983	1,056.3	5,766	1,001.0	6,084
Florida	Tampa	722110	19	73.5	94.1%	101.5%	96.3%	100.7%	98.9	8,339	219.0	9,052	402.8	5,836	391.9	5,999	1,043.3	5,781	988.7	6,100
Georgia	Atlanta	722190	1,027	63.0	94.9%	100.4%	95.4%	100.4%	99.7	8,253	220.7	8,959	399.2	5,817	388.3	5,980	1,033.9	5,762	979.8	6,080
Hawaii	Honolulu	911820	7	77.8	92.5%	101.9%	95.3%	100.9%	97.2	8,374	215.1	9,091	398.5	5,848	387.7	6,012	1,032.1	5,793	978.1	6,113
Idaho	Boise	726810	2,814	52.9	92.4%	99.4%	91.5%	100.3%	97.0	8,170	214.8	8,869	382.8	5,808	372.4	5,971	991.5	5,753	939.6	6,071
Illinois	Chicago	997338	663	50.0	101.2%	99.1%	99.9%	99.7%	106.3	8,146	235.4	8,843	417.8	5,775	406.4	5,937	1,081.9	5,720	1,025.3	6,037
Indiana	Indianapolis	724380	790	53.6	99.3%	99.5%	98.5%	99.9%	104.4	8,175	231.1	8,875	412.2	5,787	401.0	5,949	1,067.5	5,732	1,011.6	6,049
Iowa	Davenport	725349	753	49.7	101.0%	99.1%	99.6%	99.7%	106.1	8,143	234.9	8,840	416.7	5,775	405.4	5,937	1,079.2	5,721	1,022.7	6,037
Iowa	Waterloo	725480	686	47.9	101.9%	98.9%	100.3%	99.6%	107.1	8,129	237.1	8,824	419.6	5,769	408.1	5,931	1,086.6	5,715	1,029.7	6,030
Kansas	Wichita	724500	1,321	57.6	95.9%	99.9%	95.7%	100.2%	100.8	8,208	223.1	8,911	400.3	5,805	389.4	5,967	1,036.8	5,750	982.5	6,068
Kentucky	Louisville	724230	488	58.3	98.6%	99.9%	98.5%	100.1%	103.6	8,214	229.3	8,917	411.8	5,797	400.6	5,959	1,066.6	5,742	1,010.8	6,060
Louisiana	New Orleans	722316	2	68.7	96.1%	101.0%	97.6%	100.5%	101.0	8,300	223.6	9,010	408.1	5,822	397.0	5,984	1,056.9	5,767	1,001.6	6,085
Maine	Portland	726060	45	47.1	104.6%	98.8%	102.8%	99.4%	109.9	8,122	243.3	8,817	430.0	5,760	418.3	5,921	1,113.7	5,705	1,055.4	6,020
Maryland	Baltimore	724060	56	56.0	101.0%	99.7%	100.6%	99.9%	106.1	8,195	234.9	8,896	420.6	5,785	409.1	5,947	1,089.3	5,731	1,032.2	6,047
Massachusetts	Boston	725090	12	52.0	102.8%	99.3%	101.7%	99.7%	108.0	8,162	239.0	8,861	425.4	5,773	413.8	5,935	1,101.8	5,719	1,044.1	6,035
Michigan	Detroit	725375	626	51.0	100.9%	99.2%	99.8%	99.7%	106.1	8,154	234.8	8,852	417.3	5,778	405.9	5,939	1,080.7	5,723	1,024.1	6,039
Michigan	Grand Rapids	726350	803	48.9	101.1%	99.0%	99.6%	99.7%	106.3	8,137	235.2	8,833	416.8	5,773	405.4	5,935	1,079.4	5,719	1,022.9	6,035
Minnesota	Saint Paul	726584	700	46.6	102.4%	98.8%	100.6%	99.5%	107.6	8,118	238.2	8,812	420.7	5,766	409.2	5,927	1,089.5	5,711	1,032.4	6,027
Mississippi	Jackson	722350	330	65.1	96.4%	100.6%	97.3%	100.4%	101.3	8,270	224.3	8,977	407.1	5,815	396.1	5,978	1,054.4	5,760	999.2	6,078
Missouri	St. Louis	724340	531	57.5	98.7%	99.9%	98.5%	100.0%	103.8	8,208	229.7	8,910	412.0	5,795	400.8	5,957	1,067.1	5,741	1,011.2	6,058
Missouri	Kansas City	724463	742	57.0	98.2%	99.8%	97.9%	100.0%	103.2	8,203	228.4	8,905	409.4	5,796	398.3	5,958	1,060.4	5,742	1,004.9	6,059
Montana	Great Falls	727750	3,364	45.2	93.1%	98.6%	91.3%	100.0%	97.8	8,106	216.6	8,800	381.8	5,792	371.4	5,954	988.7	5,737	936.9	6,055
Nebraska	Omaha	725530	1,332	51.6	98.2%	99.3%	97.1%	99.9%	103.2	8,159	228.3	8,857	406.1	5,787	395.1	5,949	1,051.9	5,733	996.8	6,050
Nevada	Las Vegas	724846	2,203	69.1	88.6%	101.0%	90.0%	100.9%	93.1	8,303	206.0	9,013	376.3	5,848	366.0	6,012	974.5	5,793	923.5	6,113
New Hampshire	Concord	726050	346	47.0	103.5%	98.8%	101.8%	99.5%	108.8	8,121	240.8	8,816	425.6	5,763	414.0	5,924	1,102.3	5,708	1,044.5	6,024
New Jersey	Newark	725020	7	55.8	101.3%	99.7%	100.8%	99.8%	106.4	8,194	235.5	8,894	421.5	5,784	410.0	5,946	1,091.7	5,730	1,034.5	6,046
New Mexico	Albuquerque	723650	5,310	58.1	81.7%	99.9%	81.6%	101.0%	85.9	8,212	190.1	8,915	341.3	5,852	332.0	6,016	883.9	5,797	837.6	6,117
New York	New York	725053	130	55.3	101.0%	99.6%	100.5%	99.8%	106.2	8,189	235.0	8,890	420.2	5,784	408.8	5,946	1,088.3	5,730	1,031.3	6,046
New York	Syracuse	725190	413	48.9	102.5%	99.0%	101.0%	99.6%	107.8	8,137	238.5	8,833	422.6	5,769	411.1	5,930	1,094.6	5,714	1,037.3	6,030
North Carolina	Asheville	723150	2,117	56.2	93.6%	99.7%	93.2%	100.3%	98.4	8,197	217.8	8,898	390.0	5,810	379.4	5,972	1,010.0	5,755	957.1	6,073
North Carolina	Charlotte	723140	728	61.3	96.6%	100.2%	96.9%	100.3%	101.5	8,239	224.6	8,944	405.3	5,809	394.2	5,971	1,049.6	5,754	994.6	6,072
North Dakota	Bismarck	727640	1,651	43.3	100.1%	98.4%	97.9%	99.5%	105.2	8,091	232.9	8,783	409.6	5,767	398.4	5,928	1,060.7	5,712	1,005.2	6,028
Ohio	Cincinnati	724297	490	55.0	99.9%	99.6%	99.3%	99.9%	104.9	8,187	232.3	8,887	415.2	5,788	403.9	5,949	1,075.3	5,733	1,019.0	6,050
Oklahoma	Oklahoma City	723530	1,285	61.2	94.7%	100.2%	95.0%	100.4%	99.5	8,238	220.2	8,943	397.3	5,815	386.5	5,977	1,028.9	5,760	975.0	6,078
Oklahoma	Tulsa	723560	650	61.3	96.8%	100.2%	97.2%	100.2%	101.8	8,239	225.2	8,944	406.4	5,808	395.3	5,970	1,052.5	5,753	997.4	6,071
Oregon	Portland	726980	19	54.6	101.7%	99.6%	101.0%	99.8%	106.9	8,184	236.6	8,884	422.6	5,781	411.1	5,943	1,094.5	5,726	1,037.2	6,043
Pennsylvania	Philadelphia	724080	10	56.6	100.9%	99.8%	100.6%	99.9%	106.1	8,200	234.8	8,902	420.6	5,787	409.2	5,948	1,089.4	5,732	1,032.3	6,049
Pennsylvania	Wilkes-Barre	725130	930	50.3	100.1%	99.1%	98.8%	99.8%	105.2	8,148	232.9	8,845	413.5	5,779	402.2	5,941	1,070.8	5,724	1,014.7	6,041
Puerto Rico	San Juan	994043	16	80.3	91.4%	102.1%	94.6%	101.1%	96.1	8,395	212.7	9,113	395.8	5,855	385.0	6,019	1,025.0	5,800	971.3	6,121
Rhode Island	Providence	997278	33	53.0	102.3%	99.4%	101.4%	99.7%	107.5	8,171	237.9	8,870	424.1	5,776	412.5	5,938	1,098.3	5,722	1,040.7	6,038
South Carolina	Charleston	722080	40	66.5	96.9%	100.8%	98.0%	100.4%	101.8	8,282	225.3	8,990	409.9	5,816	398.7	5,978	1,061.5	5,761	1,005.9	6,079
South Carolina	Spartanburg	723120	943	61.2	95.8%	100.2%	96.2%	100.3%	100.7	8,238	223.0	8,943	402.2	5,811	391.3	5,973	1,041.8	5,756	987.2	6,074
South Dakota	Rapid City	726620	3,160	47.4	93.1%	98.8%	91.5%													

LOCATION		Adjustment Basis			Simple Cycle		Combined Cyle		Gas Turbine Based Capacity and Heat Rate Adjustments											
State	City	ASHRAE Station	Alt (ft)	Ave T (F)	MW Adj SC	HR Adj SC	MW Adj CC	HR Adj CC	2 x LM6000PF+		1 x 7F.05		1 x 7HA.01 WCT		1 x 7HA.01 ACC		2 x 7HA.02 WCT		2 x 7HA.02 ACC	
									MW Net	HR Net	MW Net	HR Net	MW Net	HR Net	MW Net	HR Net	MW Net	HR Net	MW Net	HR Net
Vermont	Burlington	726170	330	46.6	103.7%	98.8%	101.9%	99.4%	109.0	8,118	241.3	8,812	426.3	5,761	414.7	5,922	1,104.0	5,707	1,046.1	6,022
Virginia	Alexandria	724050	10	58.7	100.1%	100.0%	100.0%	100.0%	105.2	8,217	232.8	8,920	418.4	5,793	407.1	5,955	1,083.7	5,738	1,027.0	6,055
Virginia	Lynchburg	724100	940	56.6	97.6%	99.8%	97.3%	100.1%	102.6	8,200	227.1	8,902	406.9	5,797	395.9	5,959	1,053.9	5,743	998.7	6,060
Washington	Seattle	994014	7	53.2	102.3%	99.4%	101.4%	99.7%	107.5	8,172	238.0	8,871	424.2	5,777	412.7	5,938	1,098.7	5,722	1,041.2	6,038
Washington	Spokane	727850	2,353	48.1	95.8%	98.9%	94.3%	99.9%	100.6	8,130	222.8	8,826	394.3	5,789	383.6	5,951	1,021.1	5,734	967.7	6,051
West Virginia	Charleston	724140	910	55.9	98.0%	99.7%	97.6%	100.0%	103.0	8,194	228.0	8,895	408.1	5,795	397.0	5,957	1,056.9	5,740	1,001.6	6,057
Wisconsin	Green Bay	726450	687	45.5	102.9%	98.7%	100.9%	99.5%	108.1	8,109	239.3	8,803	422.0	5,762	410.5	5,923	1,092.9	5,708	1,035.7	6,023
Wyoming	Cheyenne	725640	6,130	46.6	82.4%	98.8%	81.0%	100.6%	86.6	8,118	191.8	8,812	338.7	5,828	329.5	5,991	877.2	5,773	831.3	6,092