



Proposal from
UTILITY SERVICE CO., INC.

535 Gen. Courtney Hodges Blvd · P O Box 1350 · Perry, GA 31069
Toll-free: 855-526-4413 | Fax: 478-987-2991
veolianoorthamerica.com

Date: 08/26/22

Submitted by: **Tom Stechmann**

Local Phone: (314) 420-4912

SFID:

MP / CS Asset:

Entity Proposal Submitted To ("Customer"): Raytown Water Company			Phone Number: 816-356-0333	Fax Number:
Street Address: 10017 E. 63rd Street			Description of Work to be Performed: SOW2	
City: Raytown	State: MO	Zip Code: 64133	Asset Name: AMI Project & Meter Maintenance Program	
Accounts Payable Contact Name: Chiki Thompson	Email: cthompson@raytownwater.net		Job Site Address: Raytown, MO	
Job Contact (Inspection Reports): Leslie Smart	Email: lsmart@raytownwater.net		County / Parish: Jackson	Asset Size:
			Asset Style:	

Utility Service Co., Inc. agrees to provide all labor, equipment, and materials needed to complete the following:

Please see attached Exhibit(s), which are incorporated herein by reference:

1. Exhibit A – Scope of Work
2. Exhibit B – Terms and Conditions

Please sign and date this proposal and fax one copy to our office.

One hundred ninety -----00 /100 Dollars \$ 190,000.00

Payment to be made as follows: **Payment Due in Full Upon Completion of Work – plus all applicable taxes**

Remittance Address: Utility Service Co., Inc., P O Box 207362, Dallas, TX 75320-7362

This Proposal, together with its Exhibit A – Scope of Work and Exhibit B - Terms and Conditions, and any additional exhibits that Utility Service Co., Inc. and the Customer agree to incorporate and attach to this Proposal (collectively, this "Proposal") constitutes the entire and exclusive agreement between Utility Service Co., Inc. (which for purposes herein shall collectively include its affiliate companies) and Customer (collectively, the "Parties"). This Proposal may be withdrawn by Utility Service Co., Inc. at any time prior to acceptance. Customer assents to the terms and conditions in Exhibit B and agrees that the terms and conditions in Exhibit B shall govern with respect to this Proposal and the services provided by Utility Service Co., Inc. No additional or conflicting terms or conditions included in any purchase order, hyperlink, acknowledgement or invoice of Customer not expressly incorporated into this Proposal shall be binding on the Parties or this Proposal.

Note: This proposal shall expire automatically
Ninety (90) days following the date of this Proposal.

Authorized
USCI Signature

Acceptance of Proposal The prices, scope of work, and terms and conditions of this Proposal are satisfactory and are hereby accepted. Payment will be made by Customer to Utility Service Co., Inc. as set forth herein.

Is Customer Exempt from Sales Tax? No Yes If Exempt, please provide Sales Tax Exemption Certificate.

Fiscal Year Beginning Month

JAN

Customer Signature

Date of Acceptance

9-28-22

Printed Name

CHIKI THOMPSON

FOR INTERNAL USE ONLY

SFID:

CN:

SO:

MP / CS PN:



Proposal from

UTILITY SERVICE CO., INC.

535 Gen. Courtney Hodges Blvd · P O Box 1350 · Perry, GA 31069

Toll-free: 855-526-4413 | Fax: 478-987-2991

veolianoorthamerica.com

Exhibit A – Scope of Work

Miscellaneous Repairs

- 1. See Attached "Raytown, MO - Exhibit A - SOW2".**





Proposal from
UTILITY SERVICE CO., INC.
535 Gen. Courtney Hodges Blvd · P O Box 1350 · Perry, GA 31069
Toll-free: 855-526-4413 | Fax: 478-987-2991
veolianorthamerica.com

Exhibit A – Scope of Work Continued

REMAINDER OF THIS PAGE LEFT INTENTIONALLY BLANK



Proposal from
UTILITY SERVICE CO., INC.

535 Gen. Courtney Hodges Blvd · P O Box 1350 · Perry, GA 31069
 Toll-free: 855-526-4413 | Fax: 478-987-2991
 veolianorthamerica.com

Exhibit B – Terms and Conditions

A. GENERAL TERMS AND CONDITIONS

The Terms and Conditions (the "Terms") of this Proposal govern the sale of services (the "Services") by Utility Service Co., Inc. (which for purposes herein shall include its affiliates) to the Customer. All other terms, or variations to these Terms are excluded unless agreed explicitly in writing by a numbered amendment to this Proposal executed by Utility Service Co., Inc. and the Customer. Execution of the Proposal by the Customer, whether in writing, on the Internet, by electronic signature, or by e-mail transmission of a signed Proposal shall mean acceptance that these Terms are deemed incorporated into the Proposal and shall form the contract between the Customer and Utility Service Co., Inc. These Terms shall supersede all prior terms, understandings or Proposals between the Customer and Utility Service Co., Inc. If any part of the Terms should be found to be invalid or unenforceable by a court or other competent authority, then the remainder of the Terms shall not be affected. Any notice to be given with respect to these Terms by either of the Parties shall be in writing. Notices to the Customer shall be sent to the Customer's address on the Proposal, and any notices to Utility Service Co., Inc., including notice of warranty claims by the Customer, shall be sent to: Utility Service Co., Inc., ATTN: Customer Service Department, 535 General Courtney Hodges Boulevard, Post Office Box 1350, Perry, Georgia 31069.

This Proposal has been issued based on the information provided by the Customer and on information currently available to Utility Service Co., Inc. at the time of Proposal issuance. Any changes or discrepancies in site conditions, concealed conditions where the Services will be performed, changes in environmental, health, and safety regulations or conditions, changes in Customer's financial standing, Customer's requirements, or any other relevant change or discrepancy in the factual basis upon which this Proposal was created may lead to changes in the offering, including but not limited to, changes in pricing, warranties, quoted scope of work, and/or terms and conditions. Unless stated otherwise in the Proposal, performance and/or payment bonds are not included in the price. These bonds can be purchased on request but will be at an additional cost.

B. PRICES, PAYMENT TERMS, COMMITMENT OF CUSTOMER, CREDIT REPORTING AND TAXES

Prices, which are expressed in US Dollars, are only valid for the period stated in the Proposal. If not stated, the validity period is ninety (90) days. Unless otherwise stated in the Proposal, the full price shall be due and payable upon completion of the Services, which may or may not include the installation of Equipment. All of Utility Service Co., Inc.'s invoices are due and payable upon receipt. If any payment is not made by the Customer within sixty (60) calendar days following the date of the invoice, Utility Service Co., Inc. reserves the right to charge a late payment charge of one and one-half percent (1.5%) per month of the outstanding past due balance. Any failure by Customer to make timely payment of any obligation under this Proposal shall be deemed a breach, Customer agrees to reimburse Utility Service Co., Inc. for all charges, costs, expenses and attorney's fees incurred to enforce or collect the amounts due under this Proposal. In the event Customer has a valid dispute with any invoice or amount due, such dispute must be communicated in writing to Utility Service Co., Inc. within thirty (30) days of the invoice date, describing the amount, issue and the reason for any dispute. Any amounts not disputed within this time frame will be deemed to be valid. Utility Service Co., Inc. and Customer agree to work expeditiously to resolve any dispute. Customer agrees to notify Utility Service Co., Inc. within thirty (30) days of any change in Customer's name, address, or phone number. By executing this Proposal, Customer authorizes Utility Service Co., Inc. to periodically request your credit reports and bank and trade references. Upon your request, we will inform you of the name and address of the reporting agency from which we received such a report, if any. The price listed in the Proposal excludes all taxes unless specifically stated otherwise in the Proposal. The Customer is responsible for payment of all applicable taxes, however designated or incurred in connection with the transactions under this Proposal, and agrees to reimburse Utility Service Co., Inc. for any taxes paid on Customer's behalf.

C. DELIVERY OF SERVICES AND INSTALLATION OF EQUIPMENT

The provision of Services as contemplated herein might require the installation of certain equipment (the "Equipment") on the Customer's real property or on the improvements to the Customer's real property (e.g., water storage tank, etc.). All times and dates for the delivery of Services and/or installation of Equipment are approximate, but Utility Service Co., Inc. shall use its reasonable efforts to respect them. The Parties shall each make commercially reasonable efforts to schedule the Services after the date this Proposal is executed by the Customer. Utility Service Co., Inc. shall not be liable for any loss or damage resulting from late delivery of the Services or installation of Equipment.

D. ACCESS TO CUSTOMER'S FACILITY OR REAL PROPERTY

Customer hereby agrees to provide Utility Service Co., Inc. with reasonable access to its facility or real property to perform the Services. "Reasonable access" shall include passable roads for ingress and egress as well as sufficient usable ground space for Utility Service Co., Inc.'s equipment and materials needed to perform the Services. Unless otherwise provided in this Proposal, the price of this Proposal does not include the cost to lease additional real property so that Utility Service Co., Inc. will have sufficient usable ground space to stage its equipment and materials needed to perform the Services. Any such cost would be in addition to the price of the Proposal, and if needed, the Customer agrees to negotiate an amendment to this Proposal to modify the pricing in good faith.

E. RISK OF LOSS

Risk of loss or damage to the Equipment, if applicable to this Proposal, shall pass to the Customer upon delivery of the Equipment to the named place of destination.

F. TITLE TO EQUIPMENT

If the sale of Equipment is included in this Proposal, the title in the Equipment shall remain with Utility Service Co., Inc. until the price of the Proposal is paid in full. The Customer assents that Utility Service Co., Inc. may enter upon the Customer's real property and/or facility to repossess the Equipment if payment(s) are not received in full by their due date(s).

G. SCOPE OF WARRANTY

Subject to the limitations contained herein, Utility Service Co., Inc. represents that for a period of one (1) year from the earlier of: (i) the completion of the Services (to include the installation of the Equipment, if applicable to this Proposal) or (ii) the Customer's return to use of the asset that is the subject matter of this Proposal ("Warranty Period"), the Services and Equipment, if applicable, will be free from defects in materials and workmanship and will substantially conform to the specifications set forth in Exhibit A ("Warranty"). WITH THE EXCEPTION OF THE REPRESENTATION IN THE FOREGOING SENTENCE, UTILITY SERVICE CO., INC. MAKES NO OTHER EXPRESS OR IMPLIED WARRANTIES OF ANY KIND WITH RESPECT TO THE SUBJECT MATTER HEREOF AND ALL OTHER WARRANTIES ARE HEREBY DISCLAIMED, INCLUDING, WITHOUT LIMITATION, THE IMPLIED WARRANTY OF MERCHANTABILITY, NON-INFRINGEMENT OR FITNESS FOR A PARTICULAR PURPOSE.

H. NOTIFICATION OF WARRANTY CLAIM

All claims filed under the Warranty provided in Section G shall be made in writing by the Customer within thirty (30) calendar days of identifying a defect. Customer shall provide the written notice of the claim to Utility Service Co., Inc. pursuant to Section A above, and the Customer shall provide the following information in the written notice: (i) a description of the defect giving rise to the claim; (ii) photographs showing the defect; and (iii) if the claim is related to Equipment, the serial number(s) of the Equipment which is (are) the subject of the claim.

I. EXCLUSIONS FROM WARRANTY

Occurrence of any of the following, as reasonably determined by Utility Service Co., Inc., will void the Warranty: (i) unauthorized alteration of any component(s) of the Services or the Equipment, if applicable, originally supplied by Utility Service Co., Inc., or (ii) intentional or negligent damage to Utility Service Co., Inc.'s work product or the Equipment, if applicable to this Proposal, caused by any other person or entity, including but not limited to, the Customer and its officers, employees, agents, contractors, and assigns.

J. VERIFICATION OF WARRANTY CLAIM

Utility Service Co., Inc. shall contact Customer following its receipt of notice of a claim under the Warranty. Utility Service Co., Inc. reserves the right to request additional information from the Customer or to conduct an on-site inspection of its work or the Equipment, if applicable to this Proposal, before accepting a claim. The Parties agree to cooperate and work in good faith to provide any additional information needed or to schedule an on-site visit by Utility Service Co., Inc.'s personnel to visibly inspect the work and the Equipment, if applicable. Furthermore, Utility Service Co., Inc. reserves the right to have a third party participate in the inspection of the work to verify whether the work or Equipment, if applicable, is defective under the terms of the Warranty.



Proposal from
UTILITY SERVICE CO., INC.
 535 Gen. Courtney Hodges Blvd · P O Box 1350 · Perry, GA 31069
 Toll-free: 855-526-4413 | Fax: 478-987-2991
 veolianorthamerica.com

Exhibit B – Terms and Conditions (Continued)

K. SATISFACTION OF WARRANTY CLAIM

If Utility Service Co., Inc. verifies, in good faith, that a claim under the Warranty is valid and not subject to an exclusion pursuant to Section I above, Utility Service Co., Inc. agrees to repair or replace, without expense to the Customer, any workmanship, materials, and/or Equipment, if applicable, furnished hereunder that may prove defective within the Warranty Period. The Warranty provided in this Proposal shall be the sole and exclusive remedy of the Customer.

L. INDEMNIFICATION

Utility Service Co., Inc. shall indemnify and hold harmless Customer from all claims for physical damage to third party property or injury to persons, including death, to the extent caused by the negligence of Utility Service Co., Inc. or its officers, agents, employees, and/or assigns while engaged in activities under this Proposal. Customer shall likewise indemnify and hold harmless Utility Service Co., Inc. from all claims for physical damage to third party property or injury to persons, including death, to the extent caused by negligence of the Customer or its officers, agents, employees, and/or assigns. In the event such damage or injury is caused by joint or concurrent negligence of Utility Service Co., Inc. and Customer, the loss shall be borne by each Party in proportion to its negligence. For the purpose of this Section L, (i) "Third party" shall not include Customer or any subsequent owner of the property where the Services were performed or Equipment was installed, if applicable, their subsidiaries, parents, affiliates, agents, successors or assigns including any operation or maintenance contractor, or their insurer; and (ii) no portion of the Equipment is "third party property".

M. FORCE MAJEURE

Utility Service Co., Inc. shall not be liable to the Customer for non-performance or delay in performance of any of its obligations under this Proposal due to: (i) acts of God (which include, but are not limited to, tropical storms, hurricanes, tornadoes, and earthquakes), (ii) failure of the Internet or another network, (iii) war, (iv) riot, (v) civil commotion, (vi) embargo, (vii) labor disputes, (viii) labor strikes, (ix) fire, (x) flood, (xi) theft, (xii) epidemic, (xiii) pandemic (including COVID-19), (xiv) delay in delivery of services, materials, or equipment by subcontractors, suppliers, or manufacturers, (xv) shortage of labor or materials, or (xvi) any other unforeseen event (whether or not similar in nature to those specified) outside the reasonable control of Utility Service Co., Inc.

N. LIMITATION OF LIABILITY

Neither the Customer nor Utility Service Co., Inc. shall be liable to the other for any economic (including, without limitation, loss of revenues, profits, contracts, business or anticipated savings), special, indirect, incidental, exemplary, punitive or consequential losses or damages or loss of goodwill in any way whether such liability is based on tort, contract, negligence, strict liability, product liability or otherwise arising from or relating to this Proposal or resulting from the use or the inability to use the Services or Equipment, if applicable to this Proposal, or the performance or non-performance of the Services or Equipment, if applicable. It is the responsibility of the Customer to insure itself in this regard if it so desires. The liability limit of Utility Service Co., Inc. and its affiliate companies under this Proposal, whether based in contract, warranty, tort (including negligence), strict liability, product liability or otherwise shall not exceed the price that the Customer agrees to pay Utility Service Co., Inc. in this Proposal.

O. GOVERNING LAW AND DISPUTE RESOLUTION

This Proposal and these Terms shall be construed in accordance with the laws of the state of Georgia without regard to the conflict of law principle. In the event of a dispute concerning this Proposal, the complaining Party shall notify the other Party in writing thereof. Management level representatives of both Parties shall meet at an agreed location and attempt to resolve the dispute in good faith. Should the dispute not be resolved within sixty (60) days after such notice, the complaining Party shall seek remedies exclusively through arbitration. The seat of arbitration shall be the federal district court closest to the location where the Services were performed or are scheduled to be performed, and the rules of arbitration will be the Commercial Arbitration Rules of American Arbitration Association, which are incorporated herein by reference into this Section O.

Raytown, MO

Scope Finalization Discussion





Raytown, MO

Current Timeline

Raytown, MO

November 2022

Project Start

Month 2

Month 3

Month 4

Month 5

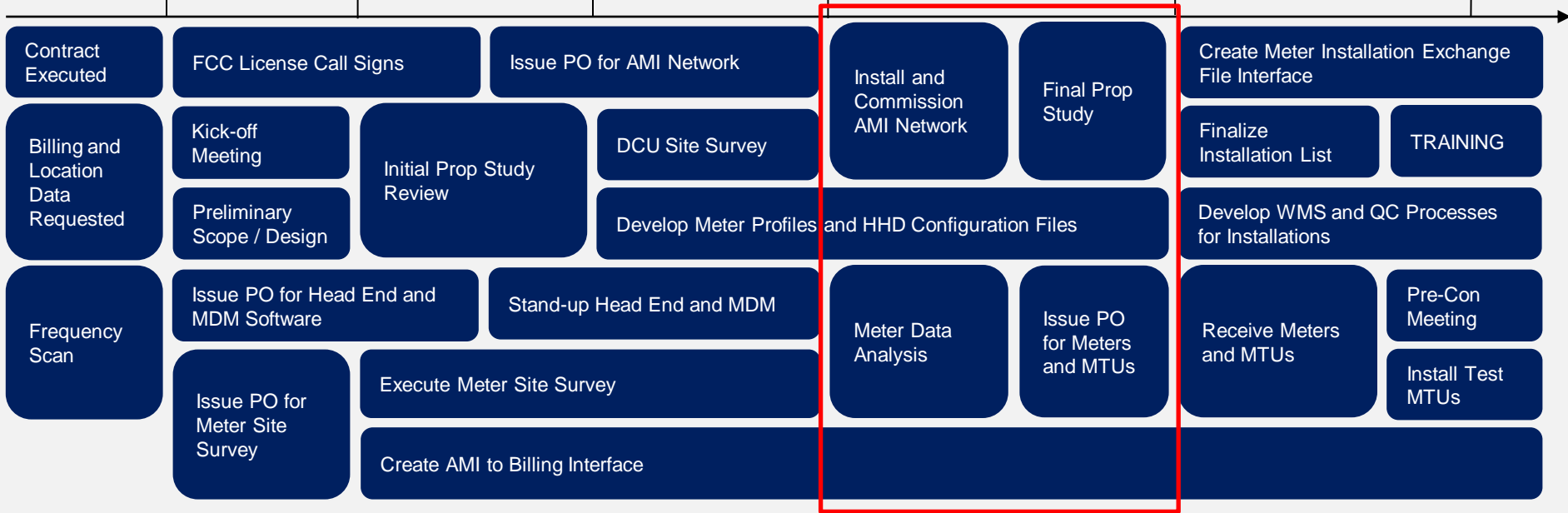

Raytown, MO

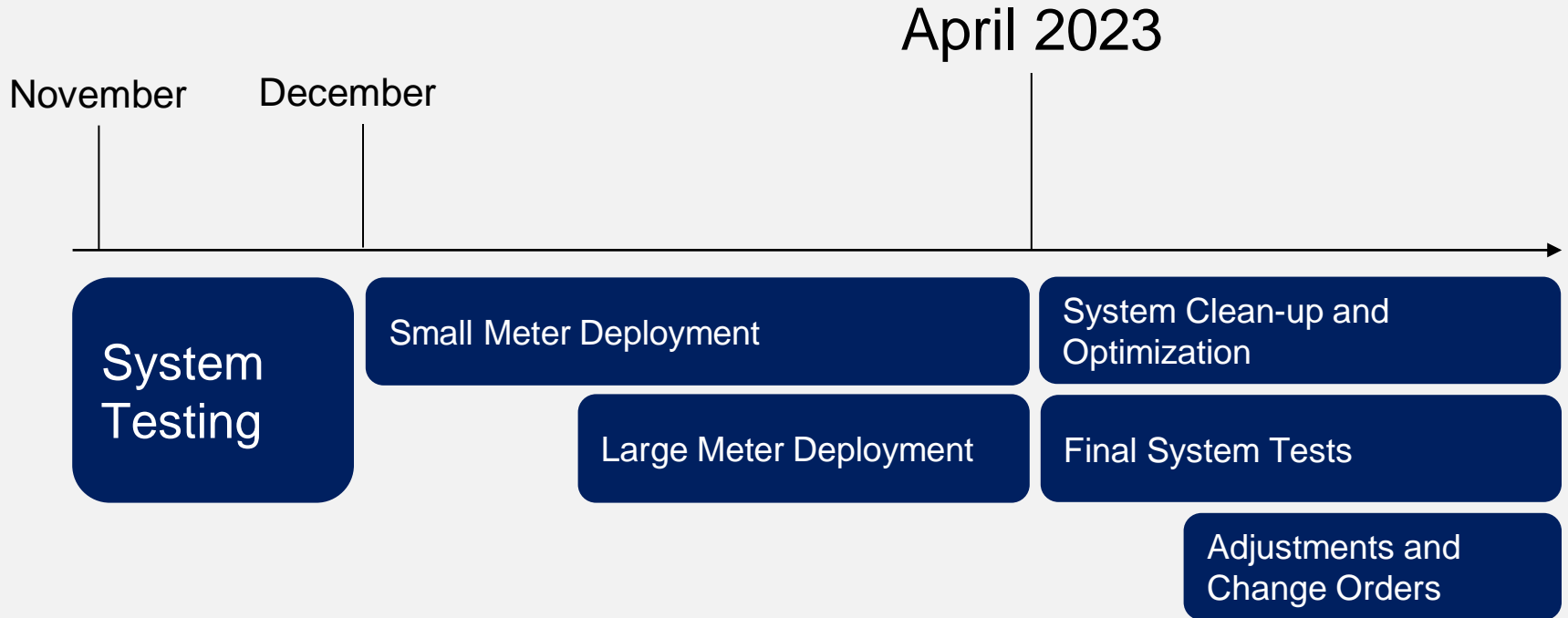



Raytown, MO

Final Scope of Work

AMI NETWORK

DCU COUNT

- Reduced from 12 > 8

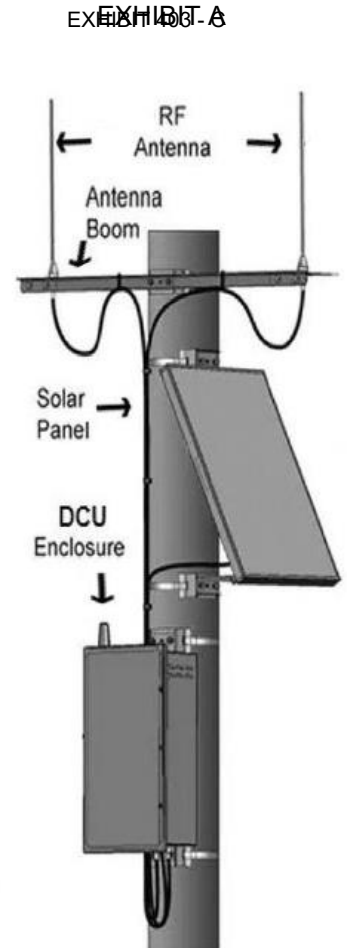

AMI NETWORK Cost Impact

Net Decrease due to:

- Reduction in 4 DCUs
- Reduction of 4 DCU installations

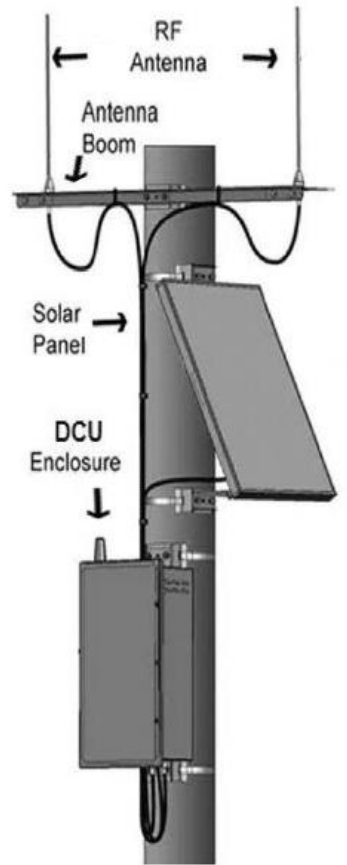

MTU Count / Type

MTU (Original)

- Std Single Port: 6,511
- Single Port TTL: 150

MTU (Final)

- Std Single Port: 6,335
- Single Port TTL: 350
- Dual Port TTL: 75

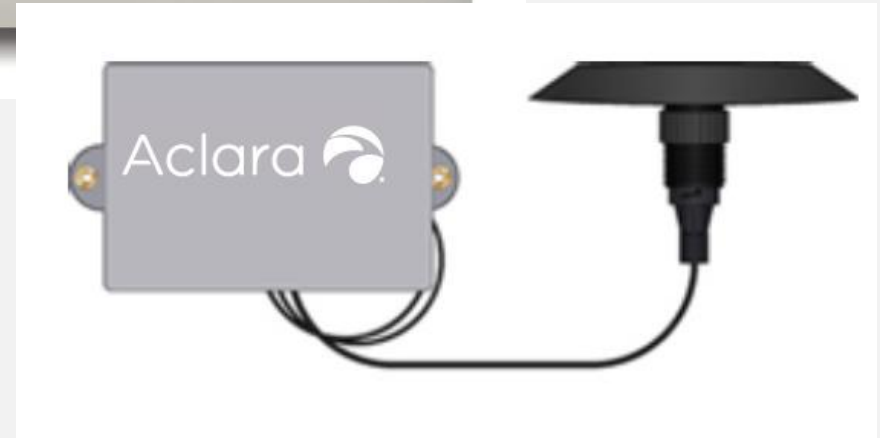

MTU Count / Type Cost Impact

Net Increase due to:

- Addition of 275 more Single/Dual Port Through-the-Lid MTUs
- Addition of 325 more Antennas
- Addition of Lid drill charge for 325 more locations

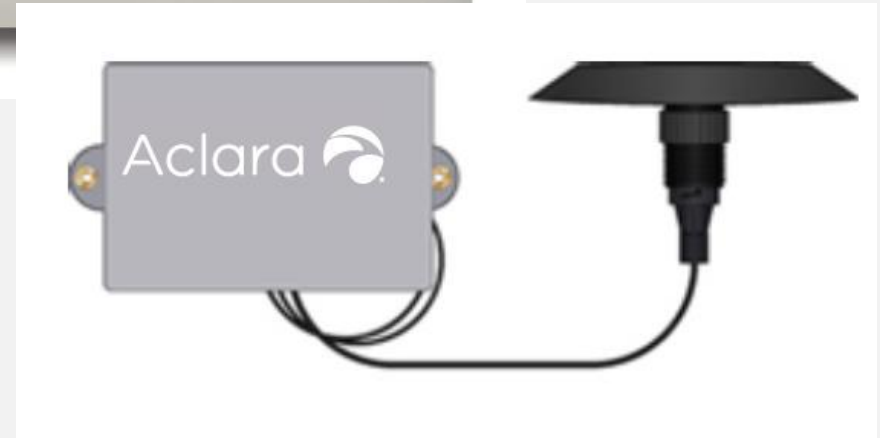
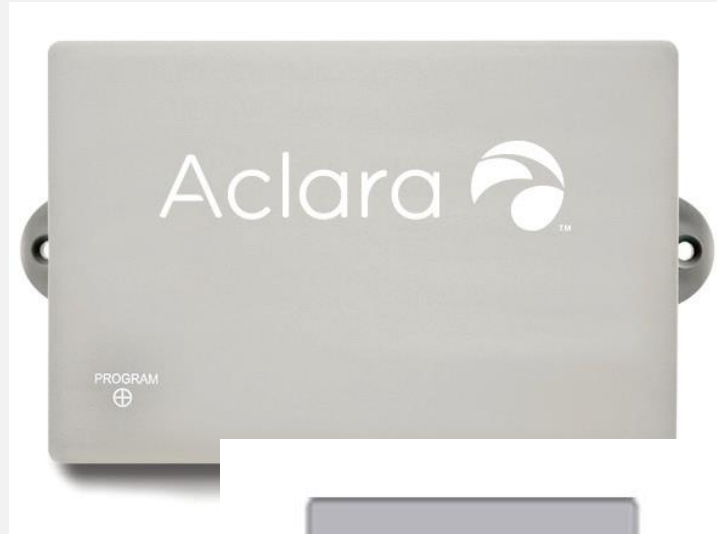

Meter Count / Type

Meters (Original)

- Residential (T-10): 6,684
- C&I (T10 / HPT): 127

Meters (Final)

- Residential (T-10): 6,684
- C&I (T10 / HPT): 117
- C&I (Comp): 6



High Performance Turbine
(3-8)



C&I Mach 10
(3-8)



T-10 PD (1.5 - 2)



T-10 PD (5/8 - 1)

Meter Count / Type Commercial Metering

ORIGINAL SCOPE

Original Meters	Count
Neptune - PD 1 1/2"	46
Neptune - PD 2"	68
Neptune - HPT 3"	11
Neptune - HPT 4"	1
Neptune - HPT 6"	1

CURRENT SCOPE

Replacement Meter	Count
1.5" x 13" Neptune T-10 Flanged	48
1.5" x 10" Neptune HPT Flanged	2
2" x 17" Neptune T-10 Flanged	58
2" x 10" Neptune HPT	1
3" x 12" Neptune HPT Flanged	9
3" x 17" Neptune Mach10 Flanged	3
4" x 14" Neptune HPT Flanged	1



Meter Count / Type Cost Impact

Net Increase due to:

- Inflationary price adjustments
- Addition of Compound / Mag Meters to the Procurement Plan



High Performance Turbine
(3-8)



C&I Mach 10
(3-8)



T-10 PD (1.5 - 2)



T-10 PD (5/8 - 1)

Meter Pit Lids

Lids (Original)

- Single style of industry standard polymer lid: 6,684

Lids (Final)

- 11.75" locking polymer lid: Qty: 5,800
- 12.0" locking polymer lid: Qty: 800
- 12.5" locking polymer lid: Qty: 100

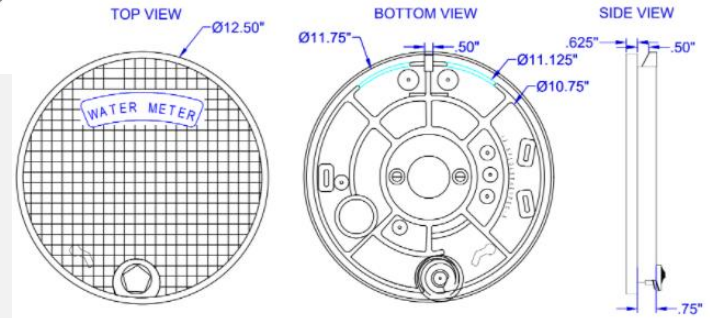
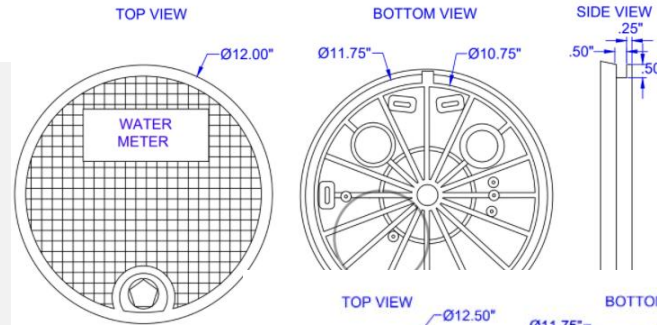
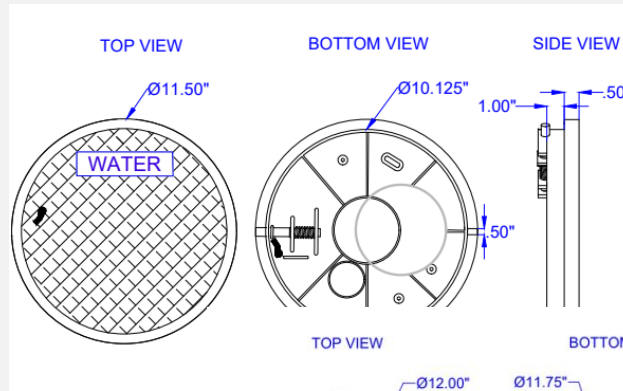

Meter Pit Lids Cost Impact

Net Increase due to:

- Locking feature added to requirements.
- No commodity lids available; requires sourcing from a premium / custom lid vendor.

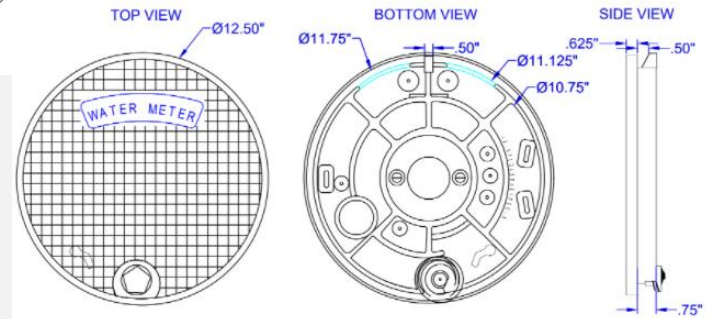
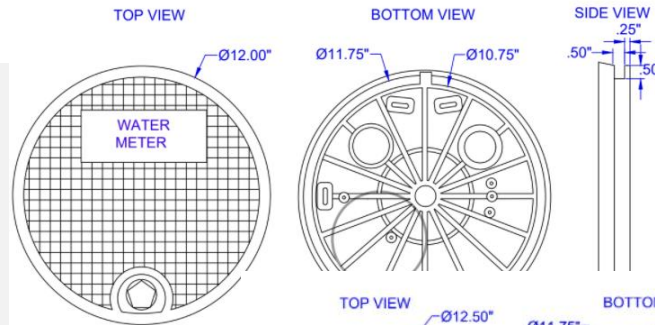
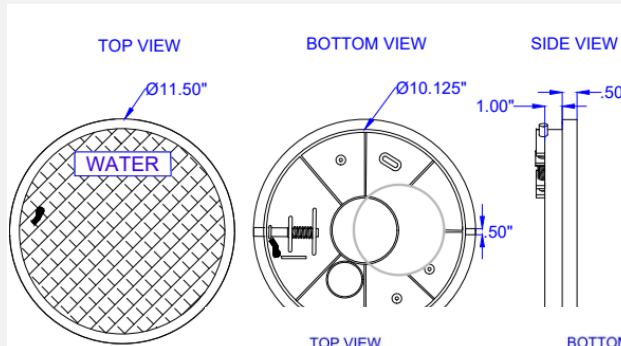

Meter Installation Cost Impact

Net Increase due to:

- Increased project complexity
- Increased lid drilling
- 12-15 large meters requiring hardware additions (spools, uniflange, etc)
- Gas, labor, inflation

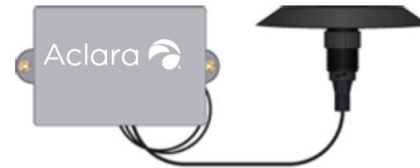
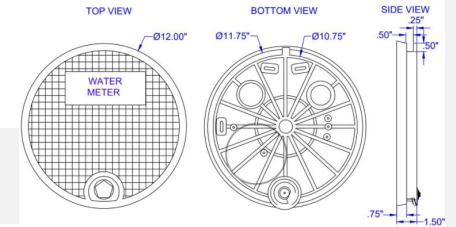
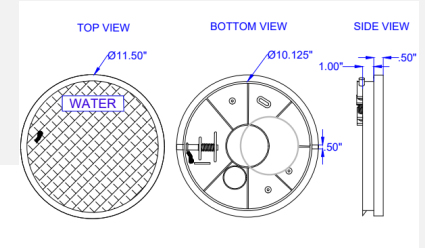

Change Order Cost



EXPECTED CHANGE ORDER WITH PROFESSIONAL PROJECT CONSIDERATION

Phase	Original	Original Projected	Professional Credit	New SOW2 Addendum
Upront Renovation	\$ 3,870,050	\$ 4,125,814	\$ (65,764)	\$ 190,000

Estimated Scope of Work Increase: \$190,000





October 5, 2022

Raytown Water Company
Attn: Chiki Thompson
10017 E. 63rd Street
Raytown, MO 64133

RE: Invoicing Under Proposal Accepted 09/28/2022

Dear Mr. Thompson:

I am writing in order to clarify the invoicing terms of the \$190,000.00 fee accepted via the attached proposal, which you signed on September 28, 2022. The attached proposal, as clarified via this letter, serves as an amendment to your SOW1. This additional fee will be invoiced at the Final Completion Milestone in your SOW1. The revised Final Completion Milestone payment will be \$770,507.50, and the revised Total Investment Fees under SOW1 will be \$4,060,050.00.

I appreciate this opportunity and look forward to working with you in the future. Please let me know if you have any questions.

Sincerely,

A handwritten signature in black ink, appearing to read "Andre Noel".

Andre Noel
Director, Revenue Management & Metering Services