

**P.S.C. Mo. - No. 36
ACCESS SERVICES TARIFF**

Southwestern Bell Telephone Company, LLC
d/b/a AT&T Missouri

Section 14
1st Revised Sheet 1
Replacing Original Sheet 1

ACCESS SERVICES

I4. SPECIAL CONSTRUCTION

This Section contains the regulations, liabilities, rates and charges applicable for special construction of Telephone Company facilities which are used to provide services offered in this and other Southwestern Bell Telephone Company, LLC Tariffs.

(AT)

When special construction of facilities is required, the provisions of this Section apply in addition to all regulations, rates and charges set forth in other Southwestern Bell Tariffs.

I4.1 Ownership of Facilities

The Telephone Company retains ownership of all specially constructed facilities.

I4.2 Interval to Provide Facilities

Based on available information and the type of service ordered, the Telephone Company will establish a completion date for the specially constructed facilities. The Telephone Company will make every reasonable effort to assure that the date is met. However, shortage of material, personnel or other factors may lengthen the installation interval. The Telephone Company does not guarantee that the facilities will be available on the scheduled date and assumes no liability if that date is missed. If the scheduled completion date cannot be met, the IC will be notified, and a new completion date will be established.

I4.3 Payments for Special Construction

I4.3.1 Payment of Charges

All bills associated with special construction are due in accordance with the appropriate regulations in the service tariff under which service is being provided.

FILED - Missouri Public Service Commission - 05/01/2024 - TN-2024-0278 - JI-2024-0140

ACCESS SERVICES

14. SPECIAL CONSTRUCTION-(Continued)

14.3 Payments for Special Construction-(Continued)

14.3.2 Start/End of Billing

Billing of recurring charges for specially constructed facilities starts on the day after the facilities are made available for use. Billing accrues through and includes the day that the specially constructed facilities are discontinued.

14.3.3 Partial Payments

To safeguard its interests during construction, the Telephone Company may require partial payments(s) for the portion of the estimated cost of the special construction for which a nonrecurring charge will apply. Partial payments may be requested as costs are incurred and will be credited against the total bill. Partial payments may not exceed the total non-recurring charge for the special construction. If any partial payment is not received by the Telephone Company by the end of the first working day of the next month, the Telephone Company will cease all work on the special construction case, and cancellation charges will apply as set forth in Paragraph 14.4.4, F., following.

14.3.4 Credit Allowance for Service Interruptions

In the event of a service interruption involving a specially constructed facility, the customer shall receive a recurring monthly charge credit in accordance with the credit allowance provisions in the appropriate service tariff associated with the affected services.

When an interruption continues due to the failure of the customer to authorize the replacement of facilities subject to a Replacement Charge, as specified in Paragraph 14.4.4, A.4., following, the credit allowance will be terminated on the seventh calendar day after the Telephone Company has provided the customer with written notification of the need for replacement. The credit allowance will resume on the day after the Telephone Company receives written authorization for the replacement from the customers.

ACCESS SERVICES

14. SPECIAL CONSTRUCTION-(Continued)

14.4 Liabilities and Charges for Special Construction

14.4.1 General

This Section describes the various charges and liabilities that may apply when the Telephone Company provides special construction of facilities in accordance with an order or a customer's projected future requirement for service. Written approval of all liabilities and charges must be provided to the Telephone Company prior to the start of construction.

14.4.2 Conditions Requiring Special Construction

Special construction is required when (1) suitable facilities are not available to meet an order for service, and (2) the Telephone Company constructs facilities and (3) one or more of the following conditions exist:

- The Telephone Company has no other requirement for the facilities constructed.
- It is requested that service be furnished using a type of facility or via a route, other than that which the Telephone Company would normally utilize in furnishing the requested service.
- More facilities are requested than would normally be required to satisfy an order.
- It is requested that construction be expedited, resulting in added cost to the Telephone Company.

14.4.3 Development of Liabilities and Charges

Special construction charges and liabilities will be developed based on estimated costs, except when actual costs are requested in writing prior to start of special construction. In order to meet a scheduled service date when actual costs are requested, an initial special construction case will be made based on estimated costs. Such case will be revised when actual costs are available.

ACCESS SERVICES

14. SPECIAL CONSTRUCTION-(Continued)

14.4 Liabilities and Charges for Special Construction-(Continued)

14.4.4 Types of Liabilities and Charges

Depending on the specifics associated with each individual case, one or more of the following special construction charges and/or liabilities may be applicable:

A. Nonrecurring Charge

A nonrecurring charge always applies and includes one or more of the following components:

1. Quotation Charge

A nonrecurring charge for the preparation of a quotation as set forth in Section 2, Paragraph 2.4.3, preceding, applies whenever an estimate for special construction charges and liabilities is requested.

2. Expediting Charge

A nonrecurring charge may include an expediting charge when it is requested that special construction be completed on an expedited basis. The charge equals the difference in estimated cost between expedited and nonexpedited construction.

3. Optional Payment

An optional payment charge may be included in the nonrecurring charge in association with a type of facility or route other than that which the Telephone Company would normally use in furnishing the requested service if lower recurring monthly charges are desired for the specially constructed facilities. This charge is equal to the excess installed cost or the total nonrecoverable cost, whichever is less. This election must be made in writing before special construction starts. If this selection is coupled with the actual cost option, the optional payment charge will reflect the actual cost of the specially constructed facilities.

ACCESS SERVICES

14. SPECIAL CONSTRUCTION-(Continued)

14.4 Liabilities and Charges for Special Construction-(Continued)

14.4.4 Types of Liabilities and Charges-(Continued)

A. Nonrecurring Charge-(Continued)

4. Replacement Charge

If any portion of specially constructed facilities for which an optional payment charge has been paid requires replacement involving capital investment, a replacement charge will apply. This charge will be in the same ratio to the total replacement cost as the initial optional payment charge was to the installed cost of the original specially constructed facilities. If any portion of the facilities subject to the replacement charge fails, service will not be restored until notification is provided in writing that replacement is required and such replacement is ordered.

5. Rearrangement Charge

If the Telephone Company is requested to rearrange existing specially constructed facilities, a nonrecurring charge component equal to the cost of rearrangement will apply.

6. Special Construction of Facilities for Use for Less Than One Month

When the Telephone Company is requested to construct facilities to provide service for less than one month, a nonrecurring charge only applies. In addition to the quotation preparation charge component, this nonrecurring charge recovers all elements of cost, including engineering, shipping of equipment, equipment installation, line-up, equipment leasing, space rental, equipment removal and any other costs associated with the construction of the facilities.

B. Maximum Termination Liability and Termination Charge

A Maximum Termination Liability is equal to the nonrecoverable costs associated with specially constructed facilities and is the maximum amount which could be applied as a Termination Charge if all specially constructed facilities were discontinued before the Maximum Termination Liability expires.

P.S.C. Mo. - No. 36
ACCESS SERVICES TARIFF

Southwestern Bell Telephone Company, LLC
d/b/a AT&T Missouri

Section 14
2nd Revised Sheet 6
Replacing 1st Revised Sheet 6

ACCESS SERVICES

14. SPECIAL CONSTRUCTION-(Continued)

14.4 Liabilities and Charges for Special Construction-(Continued)

14.4.4 Types of Liabilities and Charges-(Continued)

B. Maximum Termination Liability and Termination Charge-(Continued)

The liability period is equal to the average life of the account associated with the specially constructed facilities. When the construction involves multiple classes of plant with differing lives, the liability period is equal to the weighted average of the account lives involved in the special construction case, using nonrecoverable investment as the basis for weighting.

Example

\$20,000, \$10,000 and \$5,000 nonrecoverable investments with average account lives of 8, 18 and 25 years, respectively, are involved in the same special construction case. The maximum termination liability period will be calculated as follows:

20,000	X	8	=	160,000
10,000	X	18	=	180,000
5,000	X	25	=	125,000
35,000				465,000

$$\frac{465,000}{35,000} = 13.3$$

The maximum termination liability period would be 13 years as a result of rounding. Fractional years will be rounded down to the nearest year when they are .4 or lower and rounded up to the nearest year when they are .5 or higher. The liability period is generally expressed in terms of an effective date and expiration date.

ACCESS SERVICES

14. SPECIAL CONSTRUCTION-(Continued)

14.4 Liabilities and Charges for Special Construction-(Continued)

14.4.4 Types of Liabilities and Charges-(Continued)

B. Maximum Termination Liability and Termination Charge-(Continued)

The Maximum Termination Liability is calculated in decreasing amounts at ten-year intervals over the average account life of the facilities. In the event that the average account life of the facilities is not an even multiple of ten, the last increment will reflect the appropriate number of years remaining.

Example Illustrating a 27-Year Average Account Life

<u>Maximum Termination Liability</u>	<u>Effective Date</u>	<u>Expiration Date</u>
\$10,000	6/1/84	6/1/94
7,000	6/1/94	6/1/04
3,000	6/1/04	6/1/11

Prior to the expiration of each liability period, the customer has the option to (A) terminate the special construction case and pay the appropriate charges, or (B) extend the use of the specially constructed facilities for the new liability period.

The Telephone Company will notify the customer six months in advance of the expiration date of each ten-year liability period. The customer must provide the Telephone Company with written notification at least 30 days prior to the expiration of the liability period if termination is elected. Failure to do so will result in an automatic extension of the special construction case to the next liability period at the filed Maximum Termination Liability amount.

ACCESS SERVICES

14. SPECIAL CONSTRUCTION-(Continued)

14.4 Liabilities and Charges for Special Construction-(Continued)

14.4.4 Types of Liabilities and Charges-(Continued)

B. Maximum Termination Liability and Termination Charge-(Continued)

A Termination Charge may apply when all services using specially constructed facilities which have a Maximum Termination Liability are discontinued prior to the expiration of the liability period. The charge reflects the unamortized portion of the nonrecoverable costs at the time of termination, adjusted for net salvage and possible reuse. Administrative costs associated with the specific case of special construction and any cost for restoring a location to its original condition are also included. A Termination Charge may never exceed the Maximum Termination Liability.

A partial termination of specially constructed facilities will be provided, at the election of the customer. The amount of the Termination Charge associated with such partial termination is determined by multiplying the termination charge which would result if all services using the specially constructed facilities were discontinued, at the time partial termination is elected, by the percentage of specially constructed facilities to be partially terminated. The customer will be informed of the remaining Maximum Termination Liability amounts and the number of specially constructed facilities the customer will remain liable for.

Example:

A customer with a Maximum Termination Liability of \$100,000 for 3600 specially constructed facilities request a partial termination of 900 facilities. The Termination Charge for all facilities, at the time of election, is \$60,000. The partial termination charge, in this example, is $\$60,000 \times 900/3600$, or \$15,000.

C. Annual Underutilization Liability and Underutilization Charge

In certain instances, a customer may request the Telephone Company to construct facilities based upon the customer's projected future requirements. These facilities will be utilized for the provision of services over a specified period of time. Underutilization liabilities will apply when these conditions occur.

ACCESS SERVICES

14. SPECIAL CONSTRUCTION-(Continued)

14.4 Liabilities and Charges for Special Construction-(Continued)

14.4.4 Types of Liabilities and Charges-(Continued)

C. Annual Underutilization Liability and Underutilization Charge
(Continued)

Prior to the start of special construction, the Telephone Company and the customer will agree on (1) the quantity of facilities to be provided, and (2) the length of the planning period during which the customer expects to place the facilities in service. The planning period is hereinafter referred to as the Initial Liability Period (ILP). The ILP will have an effective and expiration date.

Underutilization occurs only if, at the expiration date of the ILP and annually thereafter, less than 70 percent of the specially constructed facilities are in service at filed tariff service rates.

An annual underutilization liability amount is filed on a per unit basis (e.g., per cable pair) for each case of special construction. This amount is equal to the annual per unit cost and includes depreciation, maintenance, administration, return, taxes and any other costs identified in the supporting documentation.

Upon the expiration of the ILP, the number of underutilized facilities, if any, are multiplied by the annual underutilization liability amount. This product is then multiplied by the number of years (including any fraction thereof) in the ILP to determine the underutilization charge.

Annually thereafter, the number of underutilized facilities, if any, existing on the anniversary of the ILP expiration date will be multiplied by the annual underutilization liability amount to determine the underutilization charge for the preceding 12-month period.

Example

A customer orders 100 services and the special construction of a 600-pair building riser cable is agreed to, based on the customer's five-year facility requirements. The ILP, in this example, would be five years. The annual underutilization liability is determined to be \$2.00 per pair. If 400 pairs were in service at the end of the ILP, there would be an underutilization of 20 pairs, i.e., $420 (70\% \text{ of } 600) - 400 = 20$. The total underutilization charge for the first 5 years would be \$200.00, or $\$2.00 \text{ per pair} \times 20 \text{ pairs} \times 5 \text{ years}$. If 420 pairs are in service at the end of the 6th year, there is no underutilization, i.e., $420 - 420 = 0$.

ACCESS SERVICES

14. SPECIAL CONSTRUCTION-(Continued)

14.4 Liabilities and Charges for Special Construction-(Continued)

14.4.4 Types of Liabilities and Charges-(Continued)

D. Recurring Monthly Charges

1. Excess Capacity Charge

A recurring monthly excess capacity charge applies when more facilities are requested and subsequently specially constructed than are required to satisfy an order for service. The charge is based on the estimated cost difference between the facilities constructed and the facilities which would normally be required to meet the order for service. Charges apply until there are sufficient services to warrant the facilities which were originally constructed.

2. Charge for Route or Type Other than Normal

When special construction is requested using a route or type of facility other than that which the Telephone Company would normally use, a recurring monthly charge in addition to the monthly rates for service is applicable. The charge is equal to the difference between the recurring costs of the specially constructed facilities and the recurring costs of the facilities the Telephone Company would have normally used.

- (a) When an Optional Payment Charge as set forth in Paragraph 14.4.4, A.3., preceding, has been elected, the recurring monthly charge will include specially constructed facility operating expenses only.

ACCESS SERVICES

14. SPECIAL CONSTRUCTION-(Continued)

14.4 Liabilities and Charges for Special Construction-(Continued)

14.4.4 Types of Liabilities and Charges-(Continued)

D. Recurring Monthly Charges-(Continued)

2. Charge for Route or Type Other than Normal-(Continued)

- (b) If the actual cost option has been elected, the recurring charge will be adjusted to reflect the actual cost of the new construction when the costs have been determined. This adjusted recurring charge is applicable from the start of service.

E. Lease Charge

This charge applies when the Telephone Company leases equipment in order to meet service requirements. The amount of the charge is equal to the net added cost to the Telephone Company caused by the lease.

F. Cancellation Charge

If a service order with which special construction is associated is cancelled prior to the start of service, a Cancellation Charge will apply. The charge will include all nonrecoverable costs incurred by the Telephone Company in association with the special construction up to and including the time of cancellation.

14.5 Deferral of Start of Service

The Telephone Company may be requested to defer the start of service which will use specially constructed facilities subject to the provisions set forth in the service tariff under which service is being provided. Requests for special construction deferral must be in writing and are subject to the following regulations:

14.5.1 Construction Has Not Begun

If the Telephone Company has not incurred any installation costs before receiving a request for deferral, the quotation charge applies. The original quotation is subject to Telephone Company review at the time of reinstatement to determine if the original charge estimates are still valid.

ACCESS SERVICES

14. SPECIAL CONSTRUCTION-(Continued)

14.5 Deferral of Start of Service-(Continued)

14.5.1 Construction Has Not Begun-(Continued)

An additional quotation charge will, therefore, apply. Any change in liabilities and charges requires concurrence in writing.

14.5.2 Construction Has Begun

If the construction of facilities has begun before the Telephone Company receives a request for deferral, charges will vary as follows:

A. All Services Are Deferred

When all services which will use specially constructed facilities are deferred, a charge based on the costs incurred by the Telephone Company during each month of the deferral will apply. Those costs include the recurring costs for that portion of the facilities already completed and any other costs associated with the deferral. The quotation charge and cost of any components of the nonrecurring charge which have been completed at the time of deferral will also apply.

B. Some Services Are Deferred

When some services which will use the specially constructed facilities are deferred, the construction case will be completed and all special construction charges will apply.

14.5.3 Construction Complete

If the construction of facilities has been completed before the Telephone Company receives a request for deferral, all special construction charges will apply.

**P.S.C. Mo. - No. 36
ACCESS SERVICES TARIFF**

Southwestern Bell Telephone Company, LLC
d/b/a AT&T Missouri

Section 14
2nd Revised Sheet 10
Replacing 1st Revised Sheet 10

ACCESS SERVICES

(RESERVED FOR FUTURE USE)

FILED - Missouri Public Service Commission - 05/01/2024 - TN-2024-0278 - JI-2024-0140

Issued: April 1, 2024

By Craig Unruh, President - Missouri
St. Louis, Missouri

Effective: May 1, 2024

**P.S.C. Mo. - No. 36
ACCESS SERVICES TARIFF**

Southwestern Bell Telephone Company, LLC
d/b/a AT&T Missouri

Section 15
5th Revised Sheet 1
Replacing 4th Revised Sheet 1

INTRALATA DIALING PARITY COST RECOVERY

INTRALATA DIALING PARITY COST RECOVERY, Section 15 of the Access Services Tariff, P.S.C. Mo.-No. 36, has been withdrawn, in its entirety, and the contents completely removed.

FILED - Missouri Public Service Commission - 05/01/2024 - TN-2024-0278 - JI-2024-0140

Issued: April 1, 2024

By Craig Unruh, President - Missouri
St. Louis, Missouri

Effective: May 1, 2024

P.S.C. Mo. - No. 36
ACCESS SERVICES TARIFF

Section 16

Southwestern Bell Telephone
Company, LLC d/b/a AT&T Missouri

5th Revised Sheet 1
Replacing 4th Revised Sheet 1

ACCESS SERVICE

16. PACKET SERVICE

The following list matches the Telephone Company's Basic Service Element BSE names to the industry standard names for each BSE.

<u>Telephone Company Names</u>	<u>Generic Name of ONA Service</u>
Reports	Call Detail Recording Reports
Restricted User Group	Closed User Groups - Packet

Packet Services utilize separate data networks, comprised of switching and transmission facilities. The networks provide for the transfer of protocol oriented data. The data is separated into discrete segments for high speed transmission through the packet networks.

There is one type of Packet Service offered by Southwestern Bell Telephone Company, LLC: (AT)

MicroLink II Service⁽¹⁾

(1) This service is only available to existing MicroLink II - Packet Switching Digital Service (X.25) customers in existing quantities at existing locations. The service will be withdrawn November 30, 2002.

ACCESS SERVICE

16. PACKET SERVICE-(Continued)

16.1 MicroLink II^R Service⁽¹⁾

16.1.1 Service Description

- A. An arrangement that allows a Voice Grade or Digital Data Special Access Service provided from Section 7 of this Tariff to be connected with MICROLINK II - Packet Switching Digital Service located on a Telephone Company premises. The interfaces are compatible with X.25 and X.75 packet switching protocols as defined by the Consultative Committee for International Telephone and Telegraph (CCITT). This committee establishes standards for packet switching networks to ensure compatibility.
- B. This arrangement permits a Voice Grade Service, a 9.6 Kbps or 56.0 Kbps Digital Data Service to interface with a packet switching port.
- C. Local MICROLINK II - Packet Switching Digital Service charges are as specified in the Digital Link Service Tariff.

16.1.2 Rate Regulations

Rate regulations found in this Tariff are applicable to the Voice Grade or Digital Data Special Access Service. Rate regulations for MICROLINK II - Packet Switching Digital Service may be found in the Missouri Digital Link Services Tariff.

When Special Access is provided with MICROLINK II - Packet Switching Digital Service, the applicable rate elements are a Channel Termination between the customer premises and its serving wire center and Optional Features, BSEs and Functions, where applicable. When the customer's serving wire center is outside the Primary Market Area, the Channel Mileage (CM) rate element will be charged in addition to the CT and Optional Feature and BSE rate elements.

- (1) This service is only available to existing MicroLink II - Packet Switching Digital Service (X.25) customers in existing quantities at existing locations. The service will be withdrawn November 30, 2002.

^RRegistered Service Mark of Southwestern Bell Telephone Company, LLC

(AT)

**P.S.C. Mo. - No. 36
ACCESS SERVICES TARIFF**

Southwestern Bell Telephone
Company, LLC d/b/a AT&T Missouri

Section 16
2nd Revised Sheet 3
Replacing 1st Revised Sheet 3

ACCESS SERVICES

16. PACKET SERVICE-(Continued)

FILED - Missouri Public Service Commission - 05/01/2024 - TN-2024-0278 - JI-2024-0140

Issued: April 1, 2024

By CRAIG UNRUH, President - Missouri
St. Louis, Missouri

Effective: May 1, 2024

**P.S.C. Mo. - No. 36
ACCESS SERVICES TARIFF**

Southwestern Bell Telephone
Company, LLC d/b/a AT&T Missouri

Section 16
2nd Revised Sheet 4
Replacing 1st Revised Sheet 4

ACCESS SERVICES

16. PACKET SERVICE-(Continued)

FILED - Missouri Public Service Commission - 05/01/2024 - TN-2024-0278 - JI-2024-0140

Issued: April 1, 2024

By CRAIG UNRUH, President - Missouri
St. Louis, Missouri

Effective: May 1, 2024

**P.S.C. Mo. - No. 36
ACCESS SERVICES TARIFF**

Southwestern Bell Telephone
Company, LLC d/b/a AT&T Missouri

Section 16
2nd Revised Sheet 5
Replacing 1st Revised Sheet 5

ACCESS SERVICES

16. PACKET SERVICE-(Continued)

FILED - Missouri Public Service Commission - 05/01/2024 - TN-2024-0278 - JI-2024-0140

Issued: April 1, 2024

By CRAIG UNRUH, President - Missouri
St. Louis, Missouri

Effective: May 1, 2024

**P.S.C. Mo. - No. 36
ACCESS SERVICES TARIFF**

Southwestern Bell Telephone
Company, LLC d/b/a AT&T Missouri

Section 16
2nd Revised Sheet 6
Replacing 1st Revised Sheet 6

ACCESS SERVICES

16. PACKET SERVICE-(Continued)

FILED - Missouri Public Service Commission - 05/01/2024 - TN-2024-0278 - JI-2024-0140

Issued: April 1, 2024

By CRAIG UNRUH, President - Missouri
St. Louis, Missouri

Effective: May 1, 2024

**P.S.C. Mo. - No. 36
ACCESS SERVICES TARIFF**

Southwestern Bell Telephone
Company, LLC d/b/a AT&T Missouri

Section 16
2nd Revised Sheet 7
Replacing 1st Revised Sheet 7

ACCESS SERVICES

16. PACKET SERVICE-(Continued)

FILED - Missouri Public Service Commission - 05/01/2024 - TN-2024-0278 - JI-2024-0140

Issued: April 1, 2024

By CRAIG UNRUH, President - Missouri
St. Louis, Missouri

Effective: May 1, 2024

**P.S.C. Mo. - No. 36
ACCESS SERVICES TARIFF**

Southwestern Bell Telephone
Company, LLC d/b/a AT&T Missouri

Section 16
2nd Revised Sheet 8
Replacing 1st Revised Sheet 8

ACCESS SERVICES

16. PACKET SERVICE-(Continued)

FILED - Missouri Public Service Commission - 05/01/2024 - TN-2024-0278 - JI-2024-0140

Issued: April 1, 2024

By CRAIG UNRUH, President - Missouri
St. Louis, Missouri

Effective: May 1, 2024

**P.S.C. Mo. - No. 36
ACCESS SERVICES TARIFF**

Southwestern Bell Telephone
Company, LLC d/b/a AT&T Missouri

Section 16
2nd Revised Sheet 9
Replacing 1st Revised Sheet 9

ACCESS SERVICES

16. PACKET SERVICE-(Continued)

FILED - Missouri Public Service Commission - 05/01/2024 - TN-2024-0278 - JI-2024-0140

Issued: April 1, 2024

By CRAIG UNRUH, President - Missouri
St. Louis, Missouri

Effective: May 1, 2024

**P.S.C. Mo. - No. 36
ACCESS SERVICES TARIFF**

Southwestern Bell Telephone
Company, LLC d/b/a AT&T Missouri

Section 16
2nd Revised Sheet 10
Replacing 1st Revised Sheet 10

ACCESS SERVICES

16. PACKET SERVICE-(Continued)

FILED - Missouri Public Service Commission - 05/01/2024 - TN-2024-0278 - JI-2024-0140

Issued: April 1, 2024

By CRAIG UNRUH, President - Missouri
St. Louis, Missouri

Effective: May 1, 2024

**P.S.C. Mo. - No. 36
ACCESS SERVICES TARIFF**

Southwestern Bell Telephone
Company, LLC d/b/a AT&T Missouri

Section 16
2nd Revised Sheet 11
Replacing 1st Revised Sheet 11

ACCESS SERVICES

16. PACKET SERVICE-(Continued)

FILED - Missouri Public Service Commission - 05/01/2024 - TN-2024-0278 - JI-2024-0140

Issued: April 1, 2024

By CRAIG UNRUH, President - Missouri
St. Louis, Missouri

Effective: May 1, 2024

**P.S.C. Mo. - No. 36
ACCESS SERVICES TARIFF**

Southwestern Bell Telephone
Company, LLC d/b/a AT&T Missouri

Section 16
2nd Revised Sheet 12
Replacing 1st Revised Sheet 12

ACCESS SERVICES

16. PACKET SERVICE-(Continued)

FILED - Missouri Public Service Commission - 05/01/2024 - TN-2024-0278 - JI-2024-0140

Issued: April 1, 2024

By CRAIG UNRUH, President - Missouri
St. Louis, Missouri

Effective: May 1, 2024

**P.S.C. Mo. - No. 36
ACCESS SERVICES TARIFF**

Southwestern Bell Telephone
Company, LLC d/b/a AT&T Missouri

Section 16
2nd Revised Sheet 13
Replacing 1st Revised Sheet 13

ACCESS SERVICES

16. PACKET SERVICE-(Continued)

FILED - Missouri Public Service Commission - 05/01/2024 - TN-2024-0278 - JI-2024-0140

Issued: April 1, 2024

By CRAIG UNRUH, President - Missouri
St. Louis, Missouri

Effective: May 1, 2024

**P.S.C. Mo. - No. 36
ACCESS SERVICES TARIFF**

Southwestern Bell Telephone
Company, LLC d/b/a AT&T Missouri

Section 16
2nd Revised Sheet 14
Replacing 1st Revised Sheet 14

ACCESS SERVICES

16. PACKET SERVICE-(Continued)

FILED - Missouri Public Service Commission - 05/01/2024 - TN-2024-0278 - JI-2024-0140

Issued: April 1, 2024

By CRAIG UNRUH, President - Missouri
St. Louis, Missouri

Effective: May 1, 2024

**P.S.C. Mo. - No. 36
ACCESS SERVICES TARIFF**

Southwestern Bell Telephone
Company, LLC d/b/a AT&T Missouri

Section 16
2nd Revised Sheet 15
Replacing 1st Revised Sheet 15

ACCESS SERVICES

16. PACKET SERVICE-(Continued)

FILED - Missouri Public Service Commission - 05/01/2024 - TN-2024-0278 - JI-2024-0140

Issued: April 1, 2024

By CRAIG UNRUH, President - Missouri
St. Louis, Missouri

Effective: May 1, 2024

**P.S.C. Mo. - No. 36
ACCESS SERVICES TARIFF**

Southwestern Bell Telephone
Company, LLC d/b/a AT&T Missouri

Section 16
2nd Revised Sheet 16
Replacing 1st Revised Sheet 16

ACCESS SERVICES

16. PACKET SERVICE-(Continued)

FILED - Missouri Public Service Commission - 05/01/2024 - TN-2024-0278 - JI-2024-0140

Issued: April 1, 2024

By CRAIG UNRUH, President - Missouri
St. Louis, Missouri

Effective: May 1, 2024

**P.S.C. Mo. - No. 36
ACCESS SERVICES TARIFF**

Southwestern Bell Telephone
Company, LLC d/b/a AT&T Missouri

Section 16
2nd Revised Sheet 17
Replacing 1st Revised Sheet 17

ACCESS SERVICES

16. PACKET SERVICE-(Continued)

FILED - Missouri Public Service Commission - 05/01/2024 - TN-2024-0278 - JI-2024-0140

Issued: April 1, 2024

By CRAIG UNRUH, President - Missouri
St. Louis, Missouri

Effective: May 1, 2024

**P.S.C. Mo. - No. 36
ACCESS SERVICES TARIFF**

Southwestern Bell Telephone
Company, LLC d/b/a AT&T Missouri

Section 16
2nd Revised Sheet 18
Replacing 1st Revised Sheet 18

ACCESS SERVICES

16. PACKET SERVICE-(Continued)

FILED - Missouri Public Service Commission - 05/01/2024 - TN-2024-0278 - JI-2024-0140

Issued: April 1, 2024

By CRAIG UNRUH, President - Missouri
St. Louis, Missouri

Effective: May 1, 2024

**P.S.C. Mo. - No. 36
ACCESS SERVICES TARIFF**

Southwestern Bell Telephone
Company, LLC d/b/a AT&T Missouri

Section 16
2nd Revised Sheet 19
Replacing 1st Revised Sheet 19

ACCESS SERVICES

16. PACKET SERVICE-(Continued)

FILED - Missouri Public Service Commission - 05/01/2024 - TN-2024-0278 - JI-2024-0140

Issued: April 1, 2024

By CRAIG UNRUH, President - Missouri
St. Louis, Missouri

Effective: May 1, 2024

**P.S.C. Mo. - No. 36
ACCESS SERVICES TARIFF**

Southwestern Bell Telephone
Company, LLC d/b/a AT&T Missouri

Section 16
2nd Revised Sheet 20
Replacing 1st Revised Sheet 20

ACCESS SERVICES

16. PACKET SERVICE-(Continued)

FILED - Missouri Public Service Commission - 05/01/2024 - TN-2024-0278 - JI-2024-0140

Issued: April 1, 2024

By CRAIG UNRUH, President - Missouri
St. Louis, Missouri

Effective: May 1, 2024

**P.S.C. Mo. - No. 36
ACCESS SERVICES TARIFF**

Southwestern Bell Telephone
Company, LLC d/b/a AT&T Missouri

Section 16
2nd Revised Sheet 21
Replacing 1st Revised Sheet 21

ACCESS SERVICES

16. PACKET SERVICE-(Continued)

FILED - Missouri Public Service Commission - 05/01/2024 - TN-2024-0278 - JI-2024-0140

Issued: April 1, 2024

By CRAIG UNRUH, President - Missouri
St. Louis, Missouri

Effective: May 1, 2024

**P.S.C. Mo. - No. 36
ACCESS SERVICES TARIFF**

Southwestern Bell Telephone
Company, LLC d/b/a AT&T Missouri

Section 16
2nd Revised Sheet 22
Replacing 1st Revised Sheet 22

ACCESS SERVICES

16. PACKET SERVICE-(Continued)

FILED - Missouri Public Service Commission - 05/01/2024 - TN-2024-0278 - JI-2024-0140

Issued: April 1, 2024

By CRAIG UNRUH, President - Missouri
St. Louis, Missouri

Effective: May 1, 2024

**P.S.C. Mo. - No. 36
ACCESS SERVICES TARIFF**

Southwestern Bell Telephone
Company, LLC d/b/a AT&T Missouri

Section 17
5th Revised Sheet 1
Replacing 4th Revised Sheet 1

ACCESS SERVICES

17. RESERVED FOR FUTURE USE

FILED - Missouri Public Service Commission - 05/01/2024 - TN-2024-0278 - JI-2024-0140

Issued: April 1, 2024

By CRAIG UNRUH, President - Missouri
St. Louis, Missouri

Effective: May 1, 2024

**P.S.C. Mo. - No. 36
ACCESS SERVICES TARIFF**

Southwestern Bell Telephone
Company, LLC d/b/a AT&T Missouri

Section 17
5th Revised Sheet 2
Replacing 4th Revised Sheet 2

ACCESS SERVICES

FILED - Missouri Public Service Commission - 05/01/2024 - TN-2024-0278 - JI-2024-0140

Issued: April 1, 2024

By CRAIG UNRUH, President - Missouri
St. Louis, Missouri

Effective: May 1, 2024

**P.S.C. Mo. - No. 36
ACCESS SERVICES TARIFF**

Southwestern Bell Telephone
Company, LLC d/b/a AT&T Missouri

Section 17
6th Revised Sheet 3
Replacing 5th Revised Sheet 3

ACCESS SERVICES

FILED - Missouri Public Service Commission - 05/01/2024 - TN-2024-0278 - JI-2024-0140

Issued: April 1, 2024

By CRAIG UNRUH, President - Missouri
St. Louis, Missouri

Effective: May 1, 2024

**P.S.C. Mo. - No. 36
ACCESS SERVICES TARIFF**

Southwestern Bell Telephone
Company, LLC d/b/a AT&T Missouri

Section 17
6th Revised Sheet 4
Replacing 5th Revised Sheet 4

ACCESS SERVICES

FILED - Missouri Public Service Commission - 05/01/2024 - TN-2024-0278 - JI-2024-0140

Issued: April 1, 2024

By CRAIG UNRUH, President - Missouri
St. Louis, Missouri

Effective: May 1, 2024

**P.S.C. Mo. - No. 36
ACCESS SERVICES TARIFF**

Southwestern Bell Telephone
Company, LLC d/b/a AT&T Missouri

Section 17
2nd Revised Sheet 5
Replacing 1st Revised Sheet 5

ACCESS SERVICES

FILED - Missouri Public Service Commission - 05/01/2024 - TN-2024-0278 - JI-2024-0140

Issued: April 1, 2024

By CRAIG UNRUH, President - Missouri
St. Louis, Missouri

Effective: May 1, 2024

**P.S.C. Mo. - No. 36
ACCESS SERVICES TARIFF**

Southwestern Bell Telephone
Company, LLC d/b/a AT&T Missouri

Section 17
2nd Revised Sheet 6
Replacing 1st Revised Sheet 6

ACCESS SERVICES

FILED - Missouri Public Service Commission - 05/01/2024 - TN-2024-0278 - JI-2024-0140

Issued: April 1, 2024

By CRAIG UNRUH, President - Missouri
St. Louis, Missouri

Effective: May 1, 2024

**P.S.C. Mo. - No. 36
ACCESS SERVICES TARIFF**

Southwestern Bell Telephone
Company, LLC d/b/a AT&T Missouri

Section 17
6th Revised Sheet 7
Replacing 5th Revised Sheet 7

ACCESS SERVICES

FILED - Missouri Public Service Commission - 05/01/2024 - TN-2024-0278 - JI-2024-0140

Issued: April 1, 2024

By CRAIG UNRUH, President - Missouri
St. Louis, Missouri

Effective: May 1, 2024

**P.S.C. Mo. - No. 36
ACCESS SERVICES TARIFF**

Southwestern Bell Telephone
Company, LLC d/b/a AT&T Missouri

Section 17
5th Revised Sheet 8
Replacing 4th Revised Sheet 8

ACCESS SERVICES

FILED - Missouri Public Service Commission - 05/01/2024 - TN-2024-0278 - JI-2024-0140

Issued: April 1, 2024

By CRAIG UNRUH, President - Missouri
St. Louis, Missouri

Effective: May 1, 2024

**P.S.C. Mo. - No. 36
ACCESS SERVICES TARIFF**

Southwestern Bell Telephone
Company, LLC d/b/a AT&T Missouri

Section 18
4th Revised Sheet 1
Replacing 3rd Revised Sheet 1

ACCESS SERVICES

18. RESERVED FOR FUTURE USE

FILED - Missouri Public Service Commission - 05/01/2024 - TN-2024-0278 - JI-2024-0140

Issued: April 1, 2024

By CRAIG UNRUH, President - Missouri
St. Louis, Missouri

Effective: May 1, 2024

**P.S.C. Mo. - No. 36
ACCESS SERVICES TARIFF**

Southwestern Bell Telephone
Company, LLC d/b/a AT&T Missouri

Section 18
4th Revised Sheet 2
Replacing 3rd Revised Sheet 2

ACCESS SERVICES

18. RESERVED FOR FUTURE USE

FILED - Missouri Public Service Commission - 05/01/2024 - TN-2024-0278 - JI-2024-0140

Issued: April 1, 2024

By CRAIG UNRUH, President - Missouri
St. Louis, Missouri

Effective: May 1, 2024

**P.S.C. Mo. - No. 36
ACCESS SERVICES TARIFF**

Southwestern Bell Telephone
Company, LLC d/b/a AT&T Missouri

Section 18
4th Revised Sheet 3
Replacing 3rd Revised Sheet 3

ACCESS SERVICES

18. RESERVED FOR FUTURE USE

FILED - Missouri Public Service Commission - 05/01/2024 - TN-2024-0278 - JI-2024-0140

Issued: April 1, 2024

By CRAIG UNRUH, President - Missouri
St. Louis, Missouri

Effective: May 1, 2024

**P.S.C. Mo. - No. 36
ACCESS SERVICES TARIFF**

Southwestern Bell Telephone
Company, LLC d/b/a AT&T Missouri

Section 18
4th Revised Sheet 4
Replacing 3rd Revised Sheet 4

ACCESS SERVICES

18. RESERVED FOR FUTURE USE

FILED - Missouri Public Service Commission - 05/01/2024 - TN-2024-0278 - JI-2024-0140

Issued: April 1, 2024

By CRAIG UNRUH, President - Missouri
St. Louis, Missouri

Effective: May 1, 2024

**P.S.C. Mo. - No. 36
ACCESS SERVICES TARIFF**

Southwestern Bell Telephone
Company, LLC d/b/a AT&T Missouri

Section 18
3rd Revised Sheet 5
Replacing 2nd Revised Sheet 5

ACCESS SERVICES

18. RESERVED FOR FUTURE USE

FILED - Missouri Public Service Commission - 05/01/2024 - TN-2024-0278 - JI-2024-0140

Issued: April 1, 2024

By CRAIG UNRUH, President - Missouri
St. Louis, Missouri

Effective: May 1, 2024

**P.S.C. Mo. - No. 36
ACCESS SERVICES TARIFF**

Southwestern Bell Telephone
Company, LLC d/b/a AT&T Missouri

Section 18
3rd Revised Sheet 6
Replacing 2nd Revised Sheet 6

ACCESS SERVICES

18. RESERVED FOR FUTURE USE

FILED - Missouri Public Service Commission - 05/01/2024 - TN-2024-0278 - JI-2024-0140

Issued: April 1, 2024

By CRAIG UNRUH, President - Missouri
St. Louis, Missouri

Effective: May 1, 2024

**P.S.C. Mo. - No. 36
ACCESS SERVICES TARIFF**

Southwestern Bell Telephone
Company, LLC d/b/a AT&T Missouri

Section 18
2nd Revised Sheet 7
Replacing 1st Revised Sheet 7

ACCESS SERVICES

18. RESERVED FOR FUTURE USE

FILED - Missouri Public Service Commission - 05/01/2024 - TN-2024-0278 - JI-2024-0140

Issued: April 1, 2024

By CRAIG UNRUH, President - Missouri
St. Louis, Missouri

Effective: May 1, 2024

**P.S.C. Mo. - No. 36
ACCESS SERVICES TARIFF**

Southwestern Bell Telephone
Company, LLC d/b/a AT&T Missouri

Section 18
2nd Revised Sheet 8
Replacing 1st Revised Sheet 8

ACCESS SERVICES

18. RESERVED FOR FUTURE USE

FILED - Missouri Public Service Commission - 05/01/2024 - TN-2024-0278 - JI-2024-0140

Issued: April 1, 2024

By CRAIG UNRUH, President - Missouri
St. Louis, Missouri

Effective: May 1, 2024

**P.S.C. Mo. - No. 36
ACCESS SERVICES TARIFF**

Southwestern Bell Telephone
Company, LLC d/b/a AT&T Missouri

Section 18
3rd Revised Sheet 9
Replacing 2nd Revised Sheet 9

ACCESS SERVICES

18. RESERVED FOR FUTURE USE

FILED - Missouri Public Service Commission - 05/01/2024 - TN-2024-0278 - JI-2024-0140

Issued: April 1, 2024

By CRAIG UNRUH, President - Missouri
St. Louis, Missouri

Effective: May 1, 2024

P.S.C. Mo. - No. 36
ACCESS SERVICES TARIFF

Southwestern Bell Telephone
Company, LLC d/b/a AT&T Missouri

Section 19
4th Revised Sheet 1
Replacing 3rd Revised Sheet 1

ACCESS SERVICES

19. NETWORK MANAGEMENT SERVICES

The following list matches the Telephone Company's Basic Service Element (BSE) names to the industry standard names for each BSE.

<u>Telephone Company Names</u>	<u>Generic Name of ONA Service</u>
Network Reconfiguration(1)	Network Reconfiguration

- (1) Effective December 15, 2018, Network Reconfiguration Service (NRS) will no longer be available for purchase by new or existing customers, and NRS service agreements may no longer be renewed. Effective July 31, 2022, the Telephone Company will no longer accept new requests for physical changes to existing service arrangements including the upgrade or downgrade of access/port speed, installation of new service, or moves to different service addresses.

ACCESS SERVICES

19. NETWORK MANAGEMENT SERVICES-(Continued)

19.1 Network Reconfiguration Service-(Continued)(1)

19.1.1 General Description

Network Reconfiguration Service is a BSE that permits customers to access a database maintained by the Telephone Company to reconfigure their dedicated network. Customers gain database access through the use of a terminal on their premises without going through normal service order procedures.

Network Reconfiguration Service allows customers direct access to, and control of, their DS3 channels, DS1 channels, subtending channels and Internodal Facilities (the facilities that connect a Digital Cross-Connect System (DCS) in one central office with a Digital Cross-Connect System in another Central Office) without going through normal service order procedures. Network Reconfiguration utilizes a central office cross-connect system for the remote reconfiguration of these channels. Customers can reconfigure their dedicated service network from their premises, or they can have the Telephone Company perform the reconfigurations.

Customers will access Network Reconfiguration Service by using a terminal on their premises in conjunction with dedicated lines provided for in Sections 7 and 16, preceding, a private line circuit provided for in P.S.C. Mo.-No. 29, Private Line Service Tariff, Digital Link Services Tariff, P.S.C. Mo.-No. 38, Section 3, or in conjunction with a local telephone line with a seven-digit telephone number.

Network Reconfiguration Service is available at those Hubs where Telephone Company cross-connect systems are located. Network Reconfiguration Hub designations are found in the National Exchange Carrier Association, Inc. Tariff filed with the F.C.C.

- (1) Effective December 15, 2018, Network Reconfiguration Service (NRS) will no longer be available for purchase by new or existing customers, and NRS service agreements may no longer be renewed. Effective July 31, 2022, the Telephone Company will no longer accept new requests for physical changes to existing service arrangements including the upgrade or downgrade of access/port speed, installation of new service, or moves to different service addresses.

ACCESS SERVICES

19. NETWORK MANAGEMENT SERVICES-(Continued)

19.1 Network Reconfiguration Service-(Continued)(1)

19.1.2 Network Reconfiguration Options

Two network reconfiguration options are available to Network Reconfiguration customers:

- On-demand
- Reservation

The on-demand option will make immediate changes to the network, while the reservation option will be executed at a specified time designated by the customer. Both types of reconfigurations are available whether the customer performs the reconfigurations or requests the Telephone Company to perform them.

19.1.3 Network Reconfiguration Functions

Network Reconfiguration Services provides the following functions:

A. Routing/Rerouting

The routing feature allows customers to select the routes that will be used to connect their circuits between DCSs. The route selection process can be controlled by various parameters according to the customer's needs. Rerouting of circuits off of a failed internodal facility to a working one is also available.

B. Renaming

Renaming permits customers to rename their network locations, circuits and facilities.

C. Special Day Definition

Special day definition gives customers the capability to specify circuit reconfiguration on special dates, e.g., payday, holidays.

D. Resource Verification

Resource verification allows customers to verify the resource availability for the reservation period in their reconfiguration request prior to the system's confirmation or denial of the request.

- (1) Effective December 15, 2018, Network Reconfiguration Service (NRS) will no longer be available for purchase by new or existing customers, and NRS service agreements may no longer be renewed. Effective July 31, 2022, the Telephone Company will no longer accept new requests for physical changes to existing service arrangements including the upgrade or downgrade of access/port speed, installation of new service, or moves to different service addresses.

ACCESS SERVICES

19. NETWORK MANAGEMENT SERVICES-(Continued)

19.1 Network Reconfiguration Service-(Continued)(1)

19.1.3 Network Reconfiguration Functions-(Continued)

E. Transaction Log

Transaction log provides customers a data base log that contains every transaction involving reconfigurations.

F. Multilevel Security

Multilevel security eliminates the outside entry into a customer's circuit network arrangement inventory.

G. Compatibility Table

Compatibility table permits customers to view the allowable access line combinations that can be used with Network Reconfiguration Service.

H. Path Priority

Path priority gives customers the ability to arrange their circuit paths in order of priority when multiple routes exist.

I. Reservation Summary Screen

Reservation summary screen allows customers to view the status of their reconfiguration reservations.

J. Simple Commands and Screens

Simple commands and screens permits customers to use simple commands on screens with easy to use menus.

K. MACRO Command/Network Modeling

MACRO command/network modeling gives customers the ability to initiate with one command, multiple two-point cross-connections. Customers can build separate network models, such as daytime models, nighttime models, and disaster recovery models and invoke their activation or switch from one to the other.

- (1) Effective December 15, 2018, Network Reconfiguration Service (NRS) will no longer be available for purchase by new or existing customers, and NRS service agreements may no longer be renewed. Effective July 31, 2022, the Telephone Company will no longer accept new requests for physical changes to existing service arrangements including the upgrade or downgrade of access/port speed, installation of new service, or moves to different service addresses.

ACCESS SERVICES

19. NETWORK MANAGEMENT SERVICES-(Continued)

19.1 Network Reconfiguration Service-(Continued)(1)

19.1.3 Network Reconfiguration Functions-(Continued)

L. Variable Bandwidth

Variable bandwidth supports scheduled reconfiguration which allows for the interchangeable use of a DS1 as either a full DS1 or one or more subtending channels.

19.1.4 Technical Specifications

Services that are cross-connected by Network Reconfiguration Service must have identical technical characteristics to ensure compatibility and proper operation, e.g., Data-to-Data, Voice-to-Voice.

Network Reconfiguration Service specifications are delineated in Technical Reference TR-TSY-000366.

19.1.5 Rate Regulations

This section contains a description of the rate elements applicable to Network Reconfiguration Service. Rate applications specific to this service are also included.

A. Rate Element Descriptions

1. Service Establishment

The Service Establishment charge applies per customer database setup. The customer database setup is a grid, built by the Telephone Company, that contains all the circuits the customer will be able to control and reconfigure. Security, as well as circuit inventory, is built into the grid, permitting the customer control of its own circuits. Also included is the provisioning of customer training. This charge includes the connection of the initial circuits.

- (1) Effective December 15, 2018, Network Reconfiguration Service (NRS) will no longer be available for purchase by new or existing customers, and NRS service agreements may no longer be renewed. Effective July 31, 2022, the Telephone Company will no longer accept new requests for physical changes to existing service arrangements including the upgrade or downgrade of access/port speed, installation of new service, or moves to different service addresses.

ACCESS SERVICES

19. NETWORK MANAGEMENT SERVICES-(Continued)

19.1 Network Reconfiguration Service-(Continued)(1)

19.1.5 Rate Regulations-(Continued)

A. Rate Element Descriptions-(Continued)

2. Database Modification

This charge applies (per customer contact, or request) each time the customer requests a subsequent modification of its database grid. A modification can be an addition or deletion of circuits terminating on the cross-connect system, or a rearrangement of the database grid, e.g., an outside move, the rearrangement of the customer's routing priority, or change in application of a DS1 (from all data to all voice).

3. Port Charges

Port Charges apply per port termination on the cross-connect system.
There are three types of charges:

- DSO Port Charge - applies per channel port termination for all Special Access Services (other than High Capacity Service or DS3 Service) per circuit on the cross-connect system.
- DS1 Port Charge - applies for 1.544 Mbps channel port termination per circuit on the cross-connect system.
- DS3 Port Charge - applies for 45 Mbps channel port termination per circuit on the cross-connect system.

4. Reconfiguration Charges

Full DS3 or DS1 bandwidth, sub DS3 or DS1 bandwidth, contiguous DS0 groupings (up to and including all 24 DS0s within a DS1), contiguous DS1 groupings (up to and including all 28 DS1s within a DS3), or individual DS0 or DS1 arrangements are as specified by the customer at the time NRS service is established. This specification limits the parameters within which the service can be reconfigured and defines how the reconfiguration charges will apply. If reconfiguration is at the DS0, DS1, or DS3 level, one reconfiguration charges applies per DS0, DS1, or DS3 circuit reconfigured; if reconfiguration is for a previously defined contiguous group of DS0s, one reconfiguration charges applies per group of DS0s reconfigured; etc.

- (1) Effective December 15, 2018, Network Reconfiguration Service (NRS) will no longer be available for purchase by new or existing customers, and NRS service agreements may no longer be renewed. Effective July 31, 2022, the Telephone Company will no longer accept new requests for physical changes to existing service arrangements including the upgrade or downgrade of access/port speed, installation of new service, or moves to different service addresses.

ACCESS SERVICES

19. NETWORK MANAGEMENT SERVICES-(Continued)

19.1 Network Reconfiguration Service-(Continued)(1)

19.1.5 Rate Regulations-(Continued)

A. Rate Element Descriptions-(Continued)

4. Reconfiguration Charges-(Continued)

One reconfiguration charge applies per cross-connect and/or disconnect successfully completed in a DCS per request. There are two types of reconfiguration charges:

- For individual reservation or demand requests performed by the customer, or for each segment of a model request performed by the customer or Telephone Company.
- For individual reservation or demand requests performed by the Telephone Company at the customer's request.

For example, if a customer wishes to reconfigure a circuit that is routed through two NRS Hub offices (the existing circuit being routed between customer premises A through the two NRS Hub offices to customer premises B, and the customer wishes to reconfigure the circuit to be rerouted between customer premises A through the two NRS Hub offices to customer premises C), two transactions would occur: one transaction to disconnect the circuit between premises A and B, and one transaction to reconnect the circuit between premises A and C. The customer would be billed four NRS charges: two for disconnecting the circuit (one for each disconnect at each NRS Hub), and two for reconnecting the circuit (one for each reconnect at each NRS Hub).

- (1) Effective December 15, 2018, Network Reconfiguration Service (NRS) will no longer be available for purchase by new or existing customers, and NRS service agreements may no longer be renewed. Effective July 31, 2022, the Telephone Company will no longer accept new requests for physical changes to existing service arrangements including the upgrade or downgrade of access/port speed, installation of new service, or moves to different service addresses.

**P.S.C. Mo. - No. 36
ACCESS SERVICES TARIFF**

Southwestern Bell Telephone
Company, LLC d/b/a AT&T Missouri

Section 19
3rd Revised Sheet 6
Replacing 2nd Revised Sheet 6

ACCESS SERVICES

19. NETWORK MANAGEMENT SERVICES-(Continued)

19.1 Network Reconfiguration Service-(Continued)(1)

19.1.5 Rate Regulations-(Continued)

B. Rate Applications

When Network Reconfiguration Service is used in conjunction with Special Access Services, the applicable rate elements per circuit are set forth in Section 7, Paragraph 7.5, preceding:

- One Channel Termination (CT) applies between the customer premises and service wire center.
- Channel Mileage, if applicable, applies between the serving wire center and the Telephone Company Network Reconfiguration Hub, or between two Network Reconfiguration Hubs.

Nonrecurring charges, as set forth in Section 7, Paragraph 7.4.1, preceding, are also applicable when existing channels must be reterminated in a Network Reconfiguration Port to provide Network Reconfiguration Service.

- (1) Effective December 15, 2018, Network Reconfiguration Service (NRS) will no longer be available for purchase by new or existing customers, and NRS service agreements may no longer be renewed. Effective July 31, 2022, the Telephone Company will no longer accept new requests for physical changes to existing service arrangements including the upgrade or downgrade of access/port speed, installation of new service, or moves to different service addresses.

Issued: April 1, 2024

By CRAIG UNRUH, President - Missouri
St. Louis, Missouri

Effective: May 1, 2024

FILED - Missouri Public Service Commission - 05/01/2024 - TN-2024-0278 - JI-2024-0140

ACCESS SERVICES

19. NETWORK MANAGEMENT SERVICES-(Continued)

19.1 Network Reconfiguration Service-(Continued)(1)

19.1.5 Rate Regulations-(Continued)

C. Service Configurations

The following diagram depicts a typical Network Reconfiguration Network with its applicable rate elements:

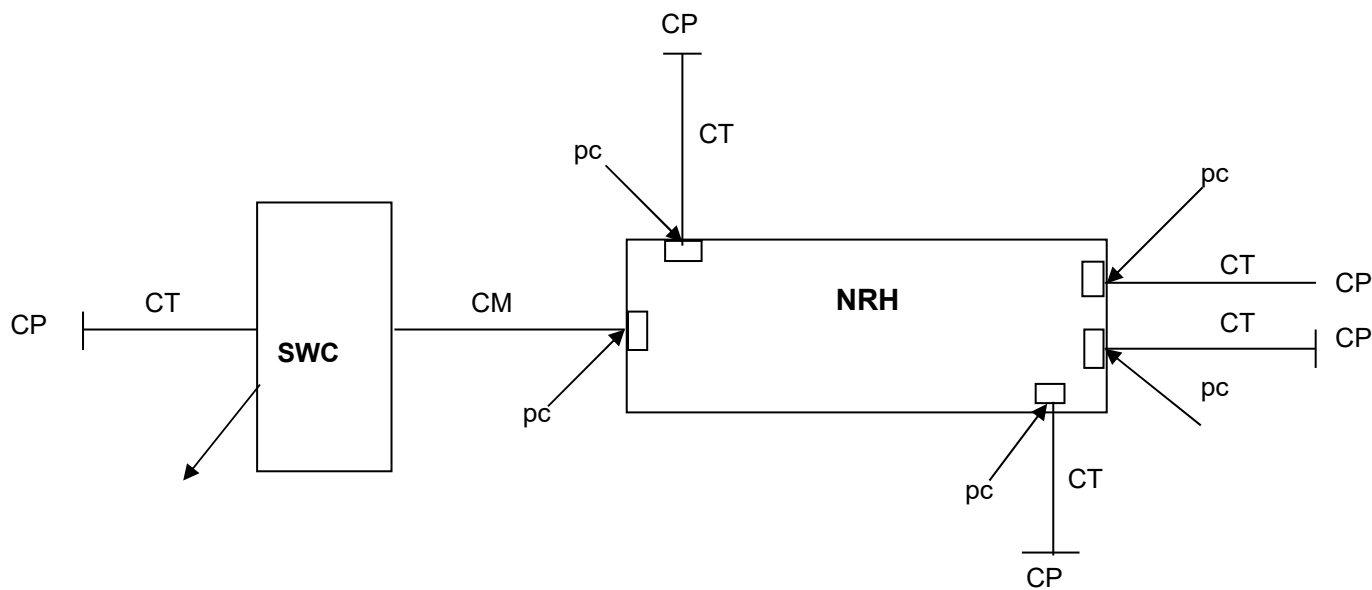

- CM = Channel Mileage
- CP = Customer Premises
- CT = Channel Termination
- NRH = Network Reconfiguration Hub
- PC = Port Charge
- SWC = Serving Wire Center

(1) Effective December 15, 2018, Network Reconfiguration Service (NRS) will no longer be available for purchase by new or existing customers, and NRS service agreements may no longer be renewed. Effective July 31, 2022, the Telephone Company will no longer accept new requests for physical changes to existing service arrangements including the upgrade or downgrade of access/port speed, installation of new service, or moves to different service addresses.

ACCESS SERVICES

19. NETWORK MANAGEMENT SERVICES-(Continued)

19.1 Network Reconfiguration Service-(Continued)(1)

19.1.5 Rate Regulations-(Continued)

C. Service Configurations-(Continued)

The following diagram depicts a Network Reconfiguration Network utilizing two Network Reconfiguration Hubs:

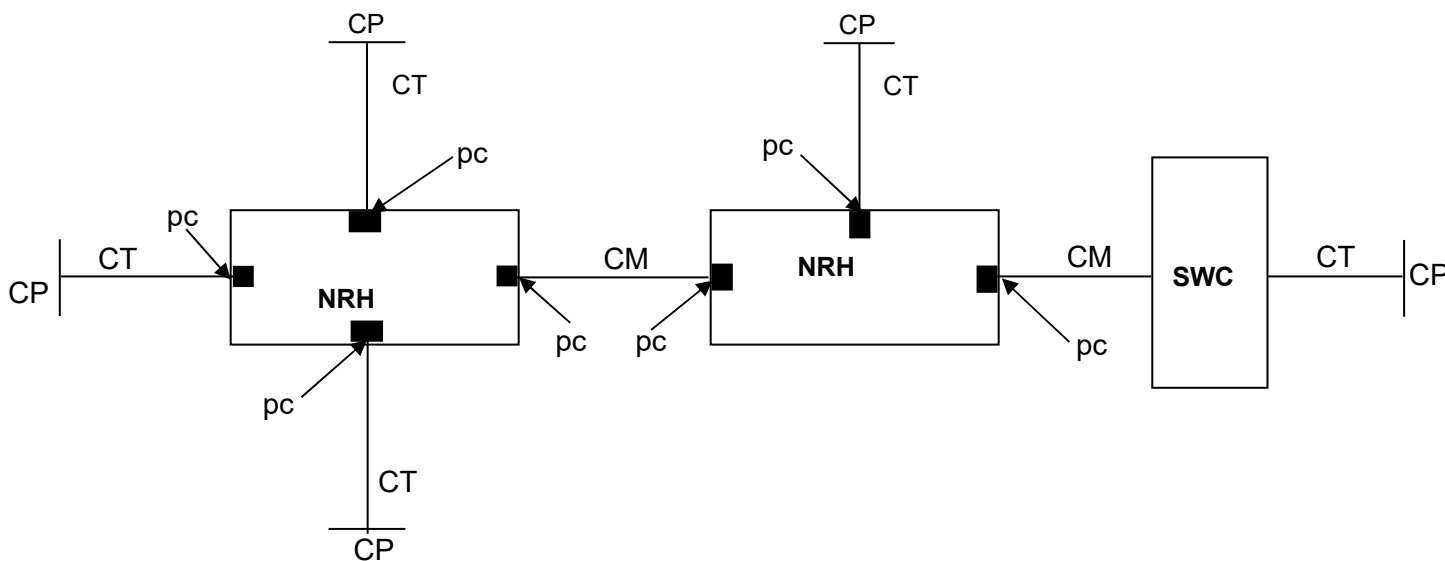

CM = Channel Mileage
 CP = Customer Premises
 CT = Channel Termination
 NRH = Network Reconfiguration Hub
 PC = Port Charge
 SWC = Serving Wire Center

(1) Effective December 15, 2018, Network Reconfiguration Service (NRS) will no longer be available for purchase by new or existing customers, and NRS service agreements may no longer be renewed. Effective July 31, 2022, the Telephone Company will no longer accept new requests for physical changes to existing service arrangements including the upgrade or downgrade of access/port speed, installation of new service, or moves to different service addresses.

**P.S.C. Mo. - No. 36
ACCESS SERVICES TARIFF**

Southwestern Bell Telephone
Company, LLC d/b/a AT&T Missouri

Section 19
3rd Revised Sheet 9
Replacing 2nd Revised Sheet 9

ACCESS SERVICES

19. NETWORK MANAGEMENT SERVICES-(Continued)

19.1 Network Reconfiguration Service-(Continued)(1)

19.1.6 Rates and Charges

	<u>USOC</u>	<u>Monthly Rates</u>	<u>Nonrecurring Charges</u>
A. Service Establishment			
- Per Database Setup	FN6DD	None	\$1,722.00
B. Database Modification,			
- per request	FN6DC	None	\$80.00
C. Port Charges			
- DS0 Port	PT5	\$11.03	\$20.00
- DS1 Port	PT6	\$45.14	\$43.00
- DS3 Port	D3D	\$500.00	\$32.00
D. Reconfiguration Charges			
Per Cross-Connect and/or Disconnect Successfully Completed			
- Per Reconfiguration Performed by Customer; or Each Segment of a Model Request Performed by Customer or Telephone Company		None	\$1.25
- Per Reconfiguration Performed by the Telephone Company at Customer Request		None	\$8.00

(1) Effective December 15, 2018, Network Reconfiguration Service (NRS) will no longer be available for purchase by new or existing customers, and NRS service agreements may no longer be renewed. Effective July 31, 2022, the Telephone Company will no longer accept new requests for physical changes to existing service arrangements including the upgrade or downgrade of access/port speed, installation of new service, or moves to different service addresses.

**P.S.C. Mo. - No. 36
ACCESS SERVICES TARIFF**

Southwestern Bell Telephone
Company, LLC d/b/a AT&T Missouri

Section 19
3rd Revised Sheet 10
Replacing 2nd Revised Sheet 10

ACCESS SERVICES

19. NETWORK MANAGEMENT SERVICES (cont'd)

FILED - Missouri Public Service Commission - 05/01/2024 - TN-2024-0278 - JI-2024-0140

Issued: April 1, 2024

By CRAIG UNRUH, President - Missouri
St. Louis, Missouri

Effective: May 1, 2024

**P.S.C. Mo. - No. 36
ACCESS SERVICES TARIFF**

Southwestern Bell Telephone
Company, LLC d/b/a AT&T Missouri

Section 19
2nd Revised Sheet 11
Replacing 1st Revised Sheet 11

ACCESS SERVICES

19. NETWORK MANAGEMENT SERVICES (cont'd)

FILED - Missouri Public Service Commission - 05/01/2024 - TN-2024-0278 - JI-2024-0140

Issued: April 1, 2024

By CRAIG UNRUH, President - Missouri
St. Louis, Missouri

Effective: May 1, 2024

**P.S.C. Mo. - No. 36
ACCESS SERVICES TARIFF**

Southwestern Bell Telephone
Company, LLC d/b/a AT&T Missouri

Section 19
2nd Revised Sheet 12
Replacing 1st Revised Sheet 12

ACCESS SERVICES

19. NETWORK MANAGEMENT SERVICES (cont'd)

FILED - Missouri Public Service Commission - 05/01/2024 - TN-2024-0278 - JI-2024-0140

Issued: April 1, 2024

By CRAIG UNRUH, President - Missouri
St. Louis, Missouri

Effective: May 1, 2024

**P.S.C. Mo. - No. 36
ACCESS SERVICES TARIFF**

Southwestern Bell Telephone
Company, LLC d/b/a AT&T Missouri

Section 19
2nd Revised Sheet 13
Replacing 1st Revised Sheet 13

ACCESS SERVICES

19. NETWORK MANAGEMENT SERVICES (cont'd)

FILED - Missouri Public Service Commission - 05/01/2024 - TN-2024-0278 - JI-2024-0140

Issued: April 1, 2024

By CRAIG UNRUH, President - Missouri
St. Louis, Missouri

Effective: May 1, 2024

**P.S.C. Mo. - No. 36
ACCESS SERVICES TARIFF**

Southwestern Bell Telephone
Company, LLC d/b/a AT&T Missouri

Section 19
3rd Revised Sheet 14
Replacing 2nd Revised Sheet 14

ACCESS SERVICES

19. NETWORK MANAGEMENT SERVICES (cont'd)

FILED - Missouri Public Service Commission - 05/01/2024 - TN-2024-0278 - JI-2024-0140

Issued: April 1, 2024

By CRAIG UNRUH, President - Missouri
St. Louis, Missouri

Effective: May 1, 2024

**P.S.C. Mo. - No. 36
ACCESS SERVICES TARIFF**

Southwestern Bell Telephone
Company, LLC d/b/a AT&T Missouri

Section 19
2nd Revised Sheet 15
Replacing 1st Revised Sheet 15

ACCESS SERVICES

19. NETWORK MANAGEMENT SERVICES (cont'd)

FILED - Missouri Public Service Commission - 05/01/2024 - TN-2024-0278 - JI-2024-0140

Issued: April 1, 2024

By CRAIG UNRUH, President - Missouri
St. Louis, Missouri

Effective: May 1, 2024

**P.S.C. Mo. - No. 36
ACCESS SERVICES TARIFF**

Southwestern Bell Telephone
Company, LLC d/b/a AT&T Missouri

Section 19
2nd Revised Sheet 16
Replacing 1st Revised Sheet 16

ACCESS SERVICES

19. NETWORK MANAGEMENT SERVICES (cont'd)

FILED - Missouri Public Service Commission - 05/01/2024 - TN-2024-0278 - JI-2024-0140

Issued: April 1, 2024

By CRAIG UNRUH, President - Missouri
St. Louis, Missouri

Effective: May 1, 2024

**P.S.C. Mo. - No. 36
ACCESS SERVICES TARIFF**

Southwestern Bell Telephone
Company, LLC d/b/a AT&T Missouri

Section 19
3rd Revised Sheet 17
Replacing 2nd Revised Sheet 17

ACCESS SERVICES

19. NETWORK MANAGEMENT SERVICES (cont'd)

FILED - Missouri Public Service Commission - 05/01/2024 - TN-2024-0278 - JI-2024-0140

Issued: April 1, 2024

By CRAIG UNRUH, President - Missouri
St. Louis, Missouri

Effective: May 1, 2024

**P.S.C. Mo. - No. 36
ACCESS SERVICES TARIFF**

Southwestern Bell Telephone
Company, LLC d/b/a AT&T Missouri

Section 19
2nd Revised Sheet 18
Replacing 1st Revised Sheet 18

ACCESS SERVICES

19. NETWORK MANAGEMENT SERVICES (cont'd)

FILED - Missouri Public Service Commission - 05/01/2024 - TN-2024-0278 - JI-2024-0140

Issued: April 1, 2024

By CRAIG UNRUH, President - Missouri
St. Louis, Missouri

Effective: May 1, 2024

**P.S.C. Mo. - No. 36
ACCESS SERVICES TARIFF**

Southwestern Bell Telephone
Company, LLC d/b/a AT&T Missouri

Section 19
2nd Revised Sheet 19
Replacing 1st Revised Sheet 19

ACCESS SERVICES

19. NETWORK MANAGEMENT SERVICES (cont'd)

FILED - Missouri Public Service Commission - 05/01/2024 - TN-2024-0278 - JI-2024-0140

Issued: April 1, 2024

By CRAIG UNRUH, President - Missouri
St. Louis, Missouri

Effective: May 1, 2024

**P.S.C. Mo. - No. 36
ACCESS SERVICES TARIFF**

Southwestern Bell Telephone
Company, LLC d/b/a AT&T Missouri

Section 19
2nd Revised Sheet 20
Replacing 1st Revised Sheet 20

ACCESS SERVICES

19. NETWORK MANAGEMENT SERVICES (cont'd)

FILED - Missouri Public Service Commission - 05/01/2024 - TN-2024-0278 - JI-2024-0140

Issued: April 1, 2024

By CRAIG UNRUH, President - Missouri
St. Louis, Missouri

Effective: May 1, 2024

**P.S.C. Mo. - No. 36
ACCESS SERVICES TARIFF**

Southwestern Bell Telephone
Company, LLC d/b/a AT&T Missouri

Section 19
2nd Revised Sheet 21
Replacing 1st Revised Sheet 21

ACCESS SERVICES

19. NETWORK MANAGEMENT SERVICES (cont'd)

FILED - Missouri Public Service Commission - 05/01/2024 - TN-2024-0278 - JI-2024-0140

Issued: April 1, 2024

By CRAIG UNRUH, President - Missouri
St. Louis, Missouri

Effective: May 1, 2024

ACCESS SERVICES

20. COMMON CHANNEL SIGNALING/SIGNALING SYSTEM 7 (CCS/SS7) INTERCONNECTION SERVICE

20.1 General

20.1.1 General Description

Common Channel Signaling/Signaling System 7 (CCS/SS7) Interconnection Service, provides a dedicated two-way signaling path between the customer-designated premises and a Telephone Company interconnecting Signal Transfer Point (STP). The customer's designated premises and the Telephone Company's STP must be in the same LATA. CCS/SS7 Interconnection Service provides interconnection with the Telephone Company's CCS/SS7 network and can be used to access Telephone Company services as they become available and as facilities permit.

CCS/SS7 Interconnection Service utilizes an STP Access Connection, an STP Access Link and an STP Port Termination. The STP Access Connection provides for the DS1 (1.544 Mbps) transmission facility between the serving wire center of the customer designated premises and the Telephone Company hub, where multiplexing from 1.544 Mbps to 56 kbps will occur. The STP Access Link provides for the 56 kbps digital transmission facility between the Telephone Company hub and the Telephone Company STP. The STP Port Termination provides for the physical termination of the customer's 56 kbps circuit into the telephone Company STP, where access to the Telephone Company's CCS/SS7 network will occur.

ACCESS SERVICES

20. COMMON CHANNEL SIGNALING/SIGNALING SYSTEM 7 (CCS/SS7)
INTERCONNECTION SERVICE-(Continued)

20.1 General-(Continued)

20.1.2 Manner of Provisioning

The customer may utilize an existing DS1 (1.544 Mbps) facility for CCS/SS7 Interconnection Service. If the customer does not have existing DS1 facilities available for use with CCS/SS7 Interconnection Service, and does not want to order a DS1 Channel, the Telephone Company will provide an STP Access Connection between the serving wire center of the customer-designated premises and the Telephone Company Hub. When a DS1 Channel or an STP Access Connection is utilized by the customer, multiplexing from 1.544 Mbps to 56 kbps will occur at the designated Telephone Company Hub. A Customer Signaling Point Code will also be installed at the Telephone Company interconnecting STP. STP locations are set forth in the National Exchange Carrier Association, Inc. Tariff F.C.C. No. 4.

One STP Port Termination is required for each 56 kbps access link utilized for CCS/SS7 Interconnection Service and will be installed at the Telephone Company interconnecting STP. A customer signaling point code will also be translated at the Telephone Company interconnecting STP. STP locations are set forth in the National Exchange Carrier Association, Inc. Tariff F.C.C. No. 4.

CCS/SS7 Interconnection Service is provisioned in A-Link pairs (multiples of 2) or B/D Link Quads (multiples of 4). Either of two architecture configurations may be used:

A Links connect a customer's Signaling Point with a Telephone Company mated Signaling Transfer Point pair per LATA.

B/D Links connect a customer's mated STP pair to a Telephone Company mated STP pair per LATA.

ACCESS SERVICES

20. COMMON CHANNEL SIGNALING/SIGNALING SYSTEM 7 (CCS/SS7)
INTERCONNECTION SERVICE-(Continued)

20.1 General-(Continued)

20.1.3 Rate Elements

The following Switched Access rate elements apply to CCS/SS7 Interconnection Service:

A. STP Access Connection

The STP Access Connection rate element provides the transmission facilities between the customer-designated premises and the Telephone Company Hub.

The STP Access Connection charges are calculated according to mileage band. There are two rates that may apply per band, i.e., a fixed monthly rate per mileage band and a monthly rate per mile.

A nonrecurring charge also applies per STP Access Connection. This charge applies on a first and additional basis.

B. STP Access Mileage

The STP Access Mileage rate element provides the 56 kbps transmission facilities between a designated Telephone Company Hub and the Telephone Company interconnecting STP.

STP Access Mileage is calculated according to mileage band. There are two rates that apply per band, i.e., a fixed monthly rate per mileage band and a monthly rate per mile.

C. STP Port Termination

The STP Port Termination rate element provides for the termination of the customer's 56 kbps circuit. One STP Port Termination must be installed at the Telephone Company interconnecting STP for each 56 kbps circuit.

There are two charges that apply to the STP Port Termination, i.e., a fixed recurring monthly rate per port termination and a nonrecurring installation charge per port.

D. Customer Signaling Point Code

The Customer Signaling Point Code rate element provides for the installation of the customer's CCS network signaling point (address) code. A nonrecurring charge applies per Customer Signaling Point Code.

**P.S.C. Mo. - No. 36
ACCESS SERVICES TARIFF**

Southwestern Bell Telephone
Company, LLC d/b/a AT&T Missouri

Section 20
1st Revised Sheet 4
Replacing Original Sheet 4

ACCESS SERVICES

**20. COMMON CHANNEL SIGNALING/SIGNALING SYSTEM 7 (CCS/SS7)
INTERCONNECTION SERVICE-(Continued)**

20.1 General-(Continued)

20.1.4 Ordering Options and Conditions

CCS/SS7 Interconnection Service is ordered under the Access Order provisions set forth in Section 5. The Access Order Charge applicable for Switched Access will apply per Access Order for the installation, addition, change or rearrangement of CCS/SS7 Interconnection Service. Other charges associated with the ordering of CCS/SS7 Interconnection Service are applicable as specified in Section 5.

20.2 Transmission Specifications

The Telephone Company will maintain existing transmission specifications on functioning service configurations installed prior to the effective date of this tariff except that service configurations having performance specifications exceeding the standards listed in this provision will be maintained at performance levels specified in the appropriate Technical Reference Publication.

20.3 Acceptance Testing

At the customer's request, the Telephone Company will, at no additional charge, cooperatively test at the time of installation.

FILED - Missouri Public Service Commission - 05/01/2024 - TN-2024-0278 - JI-2024-0140

**P.S.C. Mo. - No. 36
ACCESS SERVICES TARIFF**

Southwestern Bell Telephone
Company, LLC d/b/a AT&T Missouri

Section 20
1st Revised Sheet 5
Replacing Original Sheet 5

ACCESS SERVICES

**20. COMMON CHANNEL SIGNALING/SIGNALING SYSTEM 7 (CCS/SS7)
INTERCONNECTION SERVICE-(Continued)**

20.4 Obligations of the Telephone Company

In addition to the obligations of the Telephone Company set forth in Section 2, the Telephone Company has certain other obligations pertaining to the provision of CCS/SS7 Interconnection Service. These obligations are as follows:

20.4.1 Network Management

The Telephone Company will administer its network to ensure the provision of acceptable service levels to all telecommunication users of the Telephone Company's network services. The Telephone Company maintains the right to apply protective controls which would generally be applied as a result of occurrences such as failure or overload of Telephone Company or customer facilities, natural disasters, mass calling or national security demands. In the event that the protective controls applied by the Telephone Company result in the complete loss of service by the customer, the customer will be granted a Credit Allowance for Service Interruption as set forth in Section 2.

20.4.2 Provision of Service Performance Data

Subject to availability, end-to-end service performance data available to the Telephone Company through its own service evaluation routines, may be made available to the customer. This data provides information on STP Port availability. This data does not include service performance data which is provided under other tariff sections, e.g., testing service results. If the data is to be provided in other than paper format, the charges for such exchange will be determined on an individual case basis.

**P.S.C. Mo. - No. 36
ACCESS SERVICES TARIFF**

Southwestern Bell Telephone
Company, LLC d/b/a AT&T Missouri

Section 20
1st Revised Sheet 6
Replacing Original Sheet 6

ACCESS SERVICES

**20. COMMON CHANNEL SIGNALING/SIGNALING SYSTEM 7 (CCS/SS7)
INTERCONNECTION SERVICE-(Continued)**

20.5 Obligations of the Customer

In addition to the obligations of the customer set forth in Section 2, the customer has certain other obligations pertaining to the use of CCS/SS7 Interconnection Service. These obligations are as follows:

20.5.1 Forecast Report

The customer shall furnish to the Telephone Company, at the time CCS/SS7 Interconnection is ordered and annually thereafter, an updated three-year forecast of usage for the STP Access Connection, the STP Access Link and the STP Port Termination. The forecast shall include total annual volume and busy hour busy month volume. The Telephone Company will utilize the forecast in its own efforts to project further facility requirements.

FILED - Missouri Public Service Commission - 05/01/2024 - TN-2024-0278 - JI-2024-0140

ACCESS SERVICES

20. COMMON CHANNEL SIGNALING/SIGNALING SYSTEM 7 (CCS/SS7)
INTERCONNECTION SERVICE-(Continued)

20.6 Rate Regulations

This section contains specific regulations governing the rates and charges that apply for CCS/SS7 Interconnection Service.

20.6.1 Description of Rates and Charges

There are two types of rates and charges which apply to CCS/SS7 Interconnection Service. They are monthly recurring rates and nonrecurring charges. These rates and charges are applied differently to the various rate elements as set forth below. For billing purposes, each month is considered to have 30 days.

A. Monthly Rates

Monthly rates are fixed recurring rates that apply each month, or fraction thereof, that a specific rate element is provided.

B. Nonrecurring Charges

Nonrecurring charges are one-time charges that apply for a specific work activity (i.e., installation of a service or rearrangement of an existing service.)

Charges for the rearrangement of CCS/SS7 Interconnection Service are set forth in Section 6.

FILED - Missouri Public Service Commission - 05/01/2024 - TN-2024-0278 - JI-2024-0140

ACCESS SERVICES

20. COMMON CHANNEL SIGNALING/SIGNALING SYSTEM 7 (CCS/SS7)
INTERCONNECTION SERVICE-(Continued)

20.6 Rate Regulations-(Continued)

20.6.2 Application of Rates and Charges

STP Access Mileage and the STP Access Connection are Local Transport monthly rated Switched Access Service rate elements are not subject to the usage (i.e., Local Transport, Local Switching and Carrier Common Line) rate categories as set forth in Sections 3 and 6.

Rates and charges for the STP Access Connection, STP Access Link, STP Port Termination and the Customer Signaling Point Code apply as follows:

A. STP Access Connection

A fixed monthly rate applies for each STP Access Connection between the Telephone Company Hub and the customer-designated premises.

A monthly rate per mile applies to each airline mile between the Telephone Company Hub and the Serving Wire Center of the customer-designated premises.

A nonrecurring charge applies for the installation of each STP Access Connection. This charge is applied on a first and additional basis.

B. STP Access Link

A fixed monthly rate applies, per mileage band, for each 56 kbps access link between the Telephone Company Hub, where multiplexing from DS1 (1.544 Mbps) to a 56 kbps circuit occurs, and the Telephone Company interconnecting STP.

A monthly rate per mile applies to each airline mile between the Telephone Company Hub, where multiplexing from DS1 (1.544 Mbps) to a 56 kbps circuit occurs, and the Telephone Company interconnecting STP.

C. STP Port Termination

A monthly rate applies for each STP Port Termination installed at the Telephone Company interconnecting STP.

A nonrecurring charge applies for the installation of each STP Port Termination at the Telephone Company interconnecting STP.

**P.S.C. Mo. - No. 36
ACCESS SERVICES TARIFF**

Southwestern Bell Telephone
Company, LLC d/b/a AT&T Missouri

Section 20
1st Revised Sheet 8.1
Replacing Original Sheet 8.1

ACCESS SERVICES

**20. COMMON CHANNEL SIGNALING/SIGNALING SYSTEM 7 (CCS/SS7)
INTERCONNECTION SERVICE-(Continued)**

20.6 Rate Regulations-(Continued)

20.6.2 Application of Rates and Charges-(Continued)

D. Customer Signaling Point Code

A nonrecurring charge applies for the installation of each Customer Signaling Point Code installed at the Telephone Company interconnecting STP.

FILED - Missouri Public Service Commission - 05/01/2024 - TN-2024-0278 - JI-2024-0140

ACCESS SERVICES

20. COMMON CHANNEL SIGNALING/SIGNALING SYSTEM 7 (CCS/SS7)
INTERCONNECTION SERVICE-(Continued)

20.6 Rate Regulations-(Continued)

20.6.3 Minimum Period

CCS/SS7 Interconnection Service is provided for a minimum period of one month. When service is disconnected prior to the expiration of the minimum period, monthly charges are applicable for the balance of the minimum period. If service is disconnected after the minimum period, monthly charges will be based on the actual number of days the service is furnished, as set forth following. For the purpose of administering this regulation, with respect to the determination of charges for a fractional part of a month, every month is considered to have 30 days.

20.6.4 Moves

The regulations for moves and application of charges are set forth in Section 6.

20.6.5 Mileage Measurement

The mileage to be used to determine the monthly rate for the STP Access Connection and the STP Access Mileage is calculated on the airline distance between the locations involved, i.e., the Telephone Company Hub and the customer-designated premises, or the Telephone Company Hub and the Telephone Company interconnecting STP.

Mileage is shown in Paragraph 20.7, in terms of mileage bands. To determine the rate to be billed, first compute the mileage using the V&H coordinates method, as set forth in the National Exchange Carrier Association, Inc. Tariff F.C.C. No. 4, then find the band into which the computed mileage falls and apply the rate shown for that band. When the calculation results in a fraction of a mile, always round up to the next whole mile before determining the mileage band and applying the rates.

**P.S.C. Mo. - No. 36
ACCESS SERVICES TARIFF**

Southwestern Bell Telephone
Company, LLC d/b/a AT&T Missouri

Section 20
2nd Revised Sheet 10
Replacing 1st Revised Sheet 10

ACCESS SERVICES

20. COMMON CHANNEL SIGNALING/SIGNALING SYSTEM 7 (CCS/SS7)
INTERCONNECTION SERVICE-(Continued)

20.7 Rates and Charges

A. <u>STP Access Connection</u>	<u>USOC</u>	<u>Monthly Rate</u>	
		<u>Fixed</u>	<u>Per Mile</u>
<u>Mileage Bands</u>			
0	CCAX8	\$340.54	---
Over 0 to 4	CCAX8	403.73	\$26.45
Over 4 to 8	CCAX8	403.73	26.45
Over 8 to 25	CCAX8	403.73	26.45
Over 50	CCAX8	403.73	26.45
 <u>Nonrecurring Charge</u>			
	<u>USOC</u>	<u>First</u>	<u>Additional</u>
Per STP Access Connection	NRBSB	\$569.00	\$368.00
B. <u>STP Access Link</u>	<u>USOC</u>	<u>Monthly Rate</u>	
		<u>Fixed</u>	<u>Per Mile</u>
<u>Mileage Bands</u>			
0	1J5FX	---	---
Over 0 to 4	1J5FX	\$100.16	\$.91
Over 4 to 8	1J5FX	\$100.16	.91
Over 8 to 25	1J5FX	\$100.16	.91
Over 25 to 50	1J5FX	\$100.16	.91
Over 50	1J5FX	\$100.16	.91
C. <u>STP Port Termination</u>	<u>USOC</u>	<u>Monthly Rate</u>	<u>Nonrecurring Charge</u>
Per Port Termination	PT8SX	\$318.87	\$214.00
D. <u>Customer Signaling Point Code</u>	<u>USOC</u>	<u>Monthly Rate</u>	<u>Nonrecurring Charge</u>
	NRBSF	NA	\$ 41.00

ACCESS SERVICES

21. LINE INFORMATION DATA BASE (LIDB) VALIDATION SERVICE

21.1 General Description

Line Information Data Base (LIDB) Validation Service provides the customer the ability to query billing validation data contained in the Telephone Company's LIDB. Access to the Telephone Company's LIDB provides customers with potential toll fraud detection by validating toll billing exception data and performing public telephone checks.

The Telephone Company's LIDB is accessed through the Telephone Company's Common Channel Signaling/Signaling System 7 (CCS/SS7) Interconnection Service which utilizes American National Standards Institute (ANSI) signaling protocol. LIDB Validation Service customers must arrange for the Telephone Company's CCS/SS7 Interconnection Service, as specified in Section 20, for themselves or through another CCS/SS7 signaling transport service provider.

There is one rate category, LIDB Query, that applies to LIDB Validation Service. The LIDB Query rate category consists of two rate elements; LIDB Query Transport and LIDB Validation Query. The LIDB Query Transport provides for the transport of the LIDB query from the Signaling Transfer Points (STPs) to the Service Control Point (SCP) and back. The LIDB Validation Query provides for the actual validation of the LIDB information. In addition, other service specific charges and nonrecurring charges may apply as specified in Section 6, Paragraphs 6.7 and 6.8.

ACCESS SERVICES

21. LINE INFORMATION DATA BASE (LIDB) VALIDATION SERVICE-(Continued)

21.2 Service Description

LIDB Validation Service is provided by the Telephone Company to its customers in support of alternate billing services. LIDB Validation Service provides access to billing validation data which resides in the Telephone Company data base for use with alternate billing services. Alternate billing services allow customers' end users the ability to bill calls to an account not necessarily associated with the originating line. LIDB Validation Service supports alternate billing services such as Collect Calls and Third Number Billing.

Customers participating in LIDB Validation Service, for purposes of obtaining billing validation data that resides in the Telephone Company data base, originate queries to the LIDB from an Operator Services System (OSS) identified by an originating point code (OPC). The LIDB query is routed through one of two Telephone Company interconnecting STPs, as designated by the Telephone Company, to the Telephone Company Regional SCP where the LIDB resides. The requested billing validation data, in the form of signaling information, is passed back via either one of the two Telephone Company interconnecting STPs to the customer's designated OSS where the LIDB query was originated. The STPs locations are provided in the National Exchange Carriers Association, Inc. Tariff F.C.C. No. 4.

The Telephone Company LIDB will receive and respond to all Billed Number Screening queries, including the Telephone Company's queries. These procedures will be applied uniformly to all users of the Telephone Company's LIDB Validation Service.

LIDB Validation Service will provide the following functions on a per query basis:

- Determination of whether the billed line has decided in advance to reject certain calls billed as collect or to a third number.
- Determination of billed line as a public (including those classified as semi-public) or nonworking telephone number.

ACCESS SERVICES

21. LINE INFORMATION DATA BASE (LIDB) VALIDATION SERVICE-(Continued)

21.3 Service Provisioning

21.3.1 Manner of Provisioning

- A. All access to the Telephone Company's LIDB will occur through two Telephone Company interconnecting STPs as designated by the Telephone Company. The Telephone Company will provide customer interconnection to the Telephone Company interconnecting STPs through its CCS/SS7 Interconnection Service provided in Section 20. LIDB Validation Service customers must arrange for the Telephone Company's CCS/SS7 Interconnection Service for themselves or through another CCS/SS7 signaling transport service provider.
- B. LIDB Validation Service is ordered under the provisions specified in Section 5. Also included in that section, are other charges which may be associated with ordering LIDB Validation Service (e.g., Service Date Change Charge).

21.3.2 Limitations

Unless expressly authorized in writing by the customer and the Telephone Company, LIDB Validation Service is not to be used for purposes other than those LIDB functions described in Section 21, Paragraph 21.2, preceding. LIDB Validation Service is used for those functions only on a call-by-call basis or for limited purpose of validating billing information by a Billing Clearing House. Data accessed on LIDB may not be stored elsewhere for future use.

Proprietary information residing in the Telephone Company LIDB is protected from unauthorized access and may not be stored in a customer's data base for any reason. All information related to alternate billing services is proprietary. Examples of proprietary information are as follows:

- Billed (Line/Regional Accounting Office (RAO)) Number (resides in the Telephone Company LIDB)
- PIN Number(s) (resides in the Telephone Company LIDB)
 - Billed Number Screening (BNS) indicators (resides in the Telephone Company LIDB)
- Class of Service (resides in the Telephone Company LIDB)
- Reports on LIDB usage
- Information related to billing for LIDB usage
- LIDB usage statistics

**P.S.C. Mo. - No. 36
ACCESS SERVICES TARIFF**

Southwestern Bell Telephone
Company, LLC d/b/a AT&T Missouri

Section 21
2nd Revised Sheet 4
Replacing 1st Revised Sheet 4

ACCESS SERVICES

21. LINE INFORMATION DATA BASE (LIDB) VALIDATION SERVICE-(Continued)

21.3 Service Provisioning-(Continued)

21.3.3 LIDB Data Specifications

The Telephone Company's LIDB will contain a record for every working line number and Billed Number Group. Other exchange carriers who may store their data in the Telephone Company LIDB are requested to provide this data as well.

The Telephone Company will update the LIDB information; e.g., add, delete, and modify customer accounts as customers move, become delinquent on their account, or order new service, on a daily basis.

The Telephone Company has procedures in place to deactivate billing validation data in the event that it is being used fraudulently.

21.3.4 Provision Against Fraudulent Use of Service

End user information, pertinent to the investigation, may be shared with LIDB Validation Service customers when validation queries for the specific customer reaches the Telephone Company established fraud threshold level. This fraud threshold level will be applied uniformly to all customers.

FILED - Missouri Public Service Commission - 05/01/2024 - TN-2024-0278 - JI-2024-0140

ACCESS SERVICES

21. LINE INFORMATION DATA BASE (LIDB) VALIDATION SERVICE-(Continued)

21.3 Service Provisioning-(Continued)

21.3.5 Provision of Billing Information

When a LIDB query is received at the Telephone Company's SCP, a search is performed for the requested validation data. The Telephone Company SCP formulates a response and tallies the LIDB query for billing.

The LIDB queries are accumulated and records are generated identifying the number of queries routed to and from the SCP and processed by the OPC of the customer's OSS location. This information is delivered to the accounting office via tape or by teleprocessing for processing and billing. The query charges will be accumulated per OPC and billed to the LIDB Validation Service customer each month.

The Telephone Company will provide sufficient information with the bill to enable the customer to determine how the billed amount was calculated. Other reports may be provided as mutually agreed upon. Such agreements may involve additional charges or conditions which will be filed on an individual case basis as specified in Section 12.

21.3.6 Testing

The Telephone Company will perform testing of the LIDB Validation Service in conjunction with CCS/SS7 Interconnection Service.

21.3.7 CCS/SS7 Network Performance

The Telephone Company supports the performance standards as defined in Section 7 of TR-TSV-000905. The overall end-to-end CCS/SS7 network objective is less than ten minutes unavailability per year from any Signal Point (SP) to any other SP. The performance objective for any single SP, including an SCP, is less than three minutes unavailability per year. The combined link set from the SCP to the STP has a performance objective of less than two minutes unavailability per year.

ACCESS SERVICES

21. LINE INFORMATION DATA BASE (LIDB) VALIDATION SERVICE-(Continued)

21.3 Service Provisioning-(Continued)

21.3.8 LIDB Validation System Performance

LIDB Validation Service system downtime will be less than twelve hours per year. The LIDB validation system is capable of processing up to 100 queries per second. The response time for a query, from switch transmission to reception, should not exceed one second for 99 percent of all queries.

21.3.9 LIDB System Management

The Telephone Company will administer its LIDB to ensure the provision of acceptable service levels to all customers of the Telephone Company's LIDB Validation Service. During periods of LIDB Validation Service system congestion, an automatic call gapping procedure will be utilized to control such congestion. The automatic call gapping procedure will tell the switch the gap (how long the switch should wait before sending another query) and the duration (how long the switch should continue to perform gapping). For example, during an overload condition, the automatic call gapping procedure will tell the LIDB when to begin to drop one out of three of the queries received. This call gapping procedure will be applied uniformly to all users of the Telephone Company's LIDB Validation Service.

The Telephone Company maintains the right to invoke manual intervention of the automatic call gapping procedure to preserve the integrity of the network.

ACCESS SERVICES

21. LINE INFORMATION DATA BASE (LIDB) VALIDATION SERVICE-(Continued)

21.4 Rate Regulations

This section contains the specific regulations governing the rates and charges that apply for LIDB Validation Service.

There are two types of rates and charges which apply to LIDB Validation Service. These are usage rates and nonrecurring charges.

Specific rates and charges are set forth in Section 21, Paragraph, 21.5, following. Jurisdictional report requirements are set forth in Section 2, Paragraph 2.3.13, A.

21.4.1 Rate Elements

The following rate elements apply to LIDB Validation Service:

- LIDB Query Transport (described in (A) following)
- LIDB Validation Query (described in (B) following)

A. LIDB Query Transport

The LIDB Query Transport rate element provides for the routing of the LIDB query through one of two Telephone Company interconnecting STPs, as designated by the Telephone Company, to the Telephone Company Regional SCP where the LIDB resides, and back. The SCP and STPs locations are provided in the National Exchange Carriers Association, Inc. Tariff F.C.C. No 4.

B. LIDB Validation Query

The LIDB Validation Query rate element provides for the validation of toll billing exception data and performance of public telephone checks; i.e., determining if a billed line is a public (including those classified as semi- public) telephone number. For these validation purposes, LIDB Validation Service customers will query the LIDB located in the Telephone Company SCP via the Telephone Company CCS/SS7 network. The LIDB will respond with a verification signal message back to the LIDB Validation Service customer via the Telephone Company CCS/SS7 network.

ACCESS SERVICES

21. LINE INFORMATION DATA BASE (LIDB) VALIDATION SERVICE-(Continued)

21.4 Rate Regulations-(Continued)

21.4.2 Nonrecurring Charges

Nonrecurring charges are one-time charges that apply for a specific work activity (i.e., installation or change to an existing service). Nonrecurring charges are applicable for the establishment of LIDB Validation Service and service rearrangements. In addition, an Access Order Charge may be applicable as specified in Section 5, Paragraph 5.2.

A. Nonrecurring Charge for Establishment of Service

A nonrecurring charge applies for each request for establishment or change of existing LIDB Validation Service. The LIDB Validation Service Establishment Charge applies per OPC per request.

The nonrecurring charge for the establishment of LIDB Validation Service is set forth in Section 21, Paragraph 21.5, following.

B. Nonrecurring Charges for Service Rearrangements

Service Rearrangements are changes to existing services which do not result in changes to previously established OPCs.

Changes in previously established OPCs are treated as a discontinuance of the existing service and establishment of a new service and all applicable nonrecurring charges will apply.

Certain service rearrangements which are administrative in nature as specified in Section 6, Paragraph 6.7 will be made without charge except as noted. Provisions for service rearrangements for which nonrecurring charges will apply are also set forth in Section 6, Paragraph 6.7.

Nonrecurring charges specified in Section 6, Paragraph 6.8 will apply on a per service order basis.

P.S.C. Mo. - No. 36
ACCESS SERVICES TARIFF

Southwestern Bell Telephone
Company, LLC d/b/a AT&T Missouri

Section 21
2nd Revised Sheet 9
Replacing 1st Revised Sheet 9

ACCESS SERVICES

21. LINE INFORMATION DATA BASE (LIDB) VALIDATION SERVICE-(Continued)

21.4 Rate Regulations-(Continued)

21.4.3 Usage Rates

Usage rates are rates that apply on a per unit basis, e.g., per query, when a specific rate element is used. Usage charges are accumulated over a monthly period. For billing purposes, each month is considered to have thirty (30) days.

A. LIDB Query Transport

A LIDB Query Transport usage rate applies to each LIDB query that is routed through one of two Telephone Company's interconnecting STPs to the Telephone Company's Regional SCP where the LIDB resides and back. LIDB Query Transport charges are accumulated for each LIDB query and billed to the customer on a monthly basis.

B. LIDB Validation Query

A LIDB Validation Query usage rate applies to each LIDB query received at the Telephone Company's SCP. Query charges are accumulated for each OPC and billed to the customer on a monthly basis.

21.5 Rates and Charges

21.5.1 LIDB Query

Rate Per Query

A. Per LIDB Query Transport	\$.0045
B. Per LIDB Validation Query0260
- Billed Number Screening	

21.5.2 Service Establishment Charge

Nonrecurring Charge

Per Originating Point Code (OPC) (NRBLA)	\$ 11.00
---	----------

ACCESS SERVICES

22. COIN SERVICES

22.1 General Description

This section provides rules and regulations pertaining to equal access for handling 1+ interLATA sent-paid traffic from the Telephone Company's public pay telephones.

The Telephone Company will provide, in conjunction with Switched Access Service as set forth in Section 6 of this tariff, originating communications from its public pay telephone stations where end users pay the appropriate charges by inserting coins into the coin station equipment (i.e., sent-paid).

Easy Access Dialing from these coin stations will be provided as set forth in Section 13.

22.2 Service Description

22.2.1 1+ InterLATA Routing

1+ interLATA sent-paid access provides the customer with three options for the routing of interLATA 1+ sent-paid calls. The customer is solely responsible for all 0+ and 1+ interLATA calls originating from the Telephone Company pay telephone station when it utilizes either Option (1) or (2).

Option 1: To have both 0+ and 1+ interLATA calls directly routed to the customer (i.e., the presubscribed Interexchange Carrier).

Option 2: To receive the 0+ interLATA calls directly and select one secondary service provider per LATA to receive the 1+ interLATA sent-paid traffic. The Telephone Company must receive written authorization from the customer prior to initiating such routing.

Option 3: To receive the 0+ interLATA calls directly and continue to default the 1+ interLATA sent-paid calls. This default option will expire when the default carrier ceases to accept such traffic or when the provider is able to handle traffic as set forth in either Option 1 or 2 preceding, whichever comes first.

ACCESS SERVICES

22. COIN SERVICES-(Continued)

22.2 Service Description

22.2.1 1+ InterLATA Routing-(Continued)

Option 3: Default carrier denotes the provider of MTS and WATS which will provide for interLATA originating sent-paid coin calls from the Telephone Company's public pay telephones until the presubscribed "0+" carrier assumes this responsibility.

22.2.2 101XXXX Routing

When the customer participates in handling 1+ interLATA sent-paid calls in an equal access end office (EAEO), the Telephone Company will route 101XXXX 1+ interLATA sent-paid traffic as set forth in paragraph 22.2.1.

When the customer does not participate in the handling of such calls, the Telephone Company will route such 101XXXX calls in accordance with the customer's routing instructions.

22.3 Service Provisioning

22.3.1 Call Set Up Signaling

The Telephone Company will provide, where available, two types of call set up signaling from its pay telephones.

- A. Modified Operator Services Signaling (MOSS), as described in Bellcore's Operator Service System Generic Requirements (OSSGR), Document No. TR-NWT-001-144.
- B. Exchange Access Operator Services Signaling (EAOSS), as described in Bellcore's LATA Switching System Generic Requirements (LSSGR), Document No. TR-NWT-000-692.

22.3.2 Equal Access End Office (EAEO) Provisioning

The Telephone Company will provide 1+ interLATA sent-paid access from EAEOs to the customer's Point of Presence (POP) or its designated secondary service provider's POP via one of the following methods:

- A. Via direct routed trunks from the EAEO. The customer will be required to order Operator Trunk Functionality with coin control signaling (i.e., In Band or Expanded In Band)

ACCESS SERVICES

22. COIN SERVICES-(Continued)

22.3 Service Provisioning-(Continued)

22.3.2 Equal Access End Office (EAEO) Provisioning-(Continued)

If the EAEO is equipped with MOSS functionality, only MOSS will be provided.

If the EAEO is equipped with EAOSS functionality, either MOSS or EAOSS can be provided at the customer's option.

B. Via the Traffic Operator Position System (TOPS) tandems.

When ordering MOSS between a TOPS tandem and the customer's POP, the customer must order a separate and final trunk group for each Numbering Plan Area (NPA) within a LATA in order to identify the coin originating NPA.

For access from the TOPS tandem to the customer's POP, the customer must order a separate trunk group for each type of coin control signaling that is utilized among the EAEOs subtending a TOPS tandem.

22.3.3 Testing

The Telephone Company will perform normal acceptance testing for Coin Services as set forth in Section 6. In addition, the Telephone Company will perform testing for coin control and operator functionality features (i.e., coin collect, coin return, 1+ person-to-person, operator recall, overtime, international direct distance dialing and information calls).

The Telephone Company will provide optional testing, at the request of the customer, as set forth in Section 13.

22.3.4 Ordering

Service ordering or modification provisions will apply as set forth in Section 5.

ACCESS SERVICES

22. COIN SERVICES-(Continued)

22.4 Rate Regulations

For customers who choose Option 1 (i.e., receives both 0+ and 1+ interLATA calls directly) or Option 2 (i.e., receives 0+ interLATA calls directly and a secondary service provider receives 1+ interLATA sent-paid traffic), all applicable Switched Access rates and charges in Section 6 and the appropriate Carrier Common Line Access charges in Section 3 will be billed to the customer, whether incurred by the customer or by the secondary service provider on behalf of the customer.

For customers who choose Option 3 (i.e., receives 0+ interLATA calls directly and defaults 1+ interLATA sent-paid traffic), the following charges will be applicable:

The customer will be billed all appropriate Switched Access rates and charges in Section 6 and the Carrier Common Line Access charges as set forth in Section 3 for the 0+ interLATA calls.

The default carrier will be billed all appropriate Switched Access rates and charges as set forth in Section 6 and Carrier Common Line Access charges as set forth in Section 3 for the 1+ interLATA sent-paid traffic.

22.4.1 Liability

Where a customer selects Option 2 (i.e., to receive 0+ interLATA calls directly and a secondary service provider receives 1+ interLATA sent-paid traffic), it shall be the sole duty and obligation of the customer to make any and all arrangements for access billing and settlement with the secondary service provider.

The Telephone Company shall be indemnified, defended and held harmless by the customer and the secondary service provider for any and all claims arising out of any act or omission of the customer and/or secondary service provider relating to access billing, settlement of arrangements and any other issue concerning the relationship between the customer and its authorized secondary service provider.

**P.S.C. Mo. - No. 36
ACCESS SERVICES TARIFF**

Southwestern Bell Telephone
Company, LLC d/b/a AT&T Missouri

Section 22
1st Revised Sheet 5
Replacing Original Sheet 5

ACCESS SERVICES

22. COIN SERVICES-(Continued)

22.4 Rate Regulations-(Continued)

22.4.2 Provision of Message Call Detail Concerning Station Monies

Where Operator Trunk-Coin or Combined Coin and Non-Coin or Operator Trunk-Full Feature Optional Features for sent-paid pay telephone access is utilized by the customer or default carrier and the customer or default carrier wishes to receive the monies it is due from the monies collected by the Telephone Company from its pay telephone stations, the customer or default carrier shall furnish to the Telephone Company, at a location specified by the Telephone Company, message call detail for the sent-paid pay telephone calls by the customer, selected secondary service provider or default carrier.

The customer, selected secondary service provider or the default carrier will be required to provide call detail messages in accordance with the industry standard Exchange Message Interface (EMI) format guidelines. If a change to the industry standard format is required, the Telephone Company will provide notification to the involved customer or default carrier six months prior to the change. The message call detail records must be submitted to the Telephone Company on a daily or weekly basis, but in no case, later than 30 days from the message date.

22.4.3 Payment of Sent-Paid Monies

The Telephone Company will collect the monies from coin pay telephone stations and will determine and remit amounts due to a customer or default carrier which is provided Operator Trunk-Coin or Combined Coin and Non-Coin or Operator Trunk-Full Feature Optional Features for sent-paid telephone access as set forth in Section 6 as follows:

A. Bill Period Coin Revenue

The Telephone Company will establish a collection schedule for each of its coin pay telephone stations and will collect the monies from the coin pay stations. The Telephone Company will use trending techniques to develop the optimum coin collection schedule associated with each public telephone account. The Telephone Company's collection schedule may vary for each public telephone account. The monies collected during each bill period established by the Telephone Company will be identified by coin pay telephone station and used to develop Bill Period Coin Revenue for each coin record day (the day a record is prepared and dated to show the amount due the customer or default carrier).

ACCESS SERVICES

22. COIN SERVICES-(Continued)

22.4 Rate Regulations-(Continued)

22.4.3 Payment of Sent-Paid Monies-(Continued)

B. Total Customer or Default Carrier Coin Revenue

The total customer or default carrier coin revenue will be determined by the Telephone Company based on:

1. The message call detail records received from the customer, its selected secondary service provider or default carrier, as set forth in 22.4.2 for each bill period, and
2. The Telephone Company collection process associated with each public telephone account for sent-paid coin calls.

C. Recourse Adjustments

For each coin record day, the Telephone Company will subtract from the Total Customer or Default Carrier Coin Revenue an amount for coin station shortages. Coin station shortages are amounts resulting from unauthorized calling at coin pay telephone stations, use of unauthorized coins (e.g., foreign coins, slugs and improper use of U.S. pennies), unauthorized removal of coins from coin pay telephone stations and coin refunds beyond the Telephone Company's control.

Such amount for coin station shortages will be developed by the Telephone Company by multiplying the Total Customer or Default Carrier Coin Revenue for each coin record day by a shortage factor. Such amount will be rounded to the nearest penny. The shortage factor will be determined by dividing the yearly total coin shortage amount by the yearly total coin revenue amount (i.e., total coin revenue equals the coin revenue collected under exchange tariffs, state toll tariffs, and interstate toll tariffs). The total coin shortage amount and the total revenue amount will be determined by the Telephone Company through an annual study.

ACCESS SERVICES

22. COIN SERVICES-(Continued)

22.4 Rate Regulations-(Continued)

22.4.3 Payment of Sent-Paid Monies-(Continued)

D. Payment of Net Customer or Default Carrier Coin Revenue

The Telephone Company will determine the Net Customer or Default Carrier Coin Revenue for each coin record day by subtracting the amount for coin station shortages determined as set forth in C preceding from the Total Customer or Default Carrier Coin Revenue determined as set forth in B preceding.

E. Refund of Monies from Coin Pay Telephone Stations

When the customer does not choose to receive the 1+ interLATA sent-paid traffic, the secondary service provider or the default carrier will be responsible for processing coin refunds to its end user customers.

22.4.4 Audit Provisions

Upon 30-day written notice by the Telephone Company, the customer or the default carrier shall have the right to audit and examine all records and accounts, as may be deemed necessary under recognized accounting practices, which contain information relevant to the determination of the jurisdiction of monies associated with the pay telephones. It shall be the sole responsibility of the customer to obtain all such necessary information from its selected secondary service provider. The Telephone Company, the customer and the default carrier shall have the following audit rights for Coin Services:

- A. The Telephone Company or its authorized representative may, once per year during normal business hours, audit the call message detail records, including any supporting documentation, of the customer, its selected secondary service provider or the default carrier.
- B. The customer, the default carrier or their authorized representative, may once per year during normal business hours, audit the Telephone Company's records and accounts, including any supporting documentation, to determine the amounts payable to the customer or the default carrier.

**P.S.C. Mo. - No. 36
ACCESS SERVICES TARIFF**

Southwestern Bell Telephone
Company, LLC d/b/a AT&T Missouri

Section 22
1st Revised Sheet 8
Replacing Original Sheet 8

ACCESS SERVICES

22. COIN SERVICES-(Continued)

22.4 Rate Regulations-(Continued)

22.4.4 Audit Provisions-(Continued)

- C. If the parties involved mutually agree upon an independent auditor, the Telephone Company and the customer or the default carrier shall agree upon the audit period and make available documentation as set forth in A and B preceding during normal business hours at an agreed upon location.
- D. Adjustment shall be made by the proper party to compensate for any errors or omissions disclosed by such examination or audit. Neither such right to examine and audit nor the right to receive such adjustment shall be affected by any statement to the contrary, appearing on checks or otherwise, unless such statement expressly waiving such right appears in a letter signed by the authorized representative of the party having such right and delivered to the other party.
- E. All information received or reviewed by the Telephone Company, the customer, the default carrier or their authorized representative is to be considered confidential and is not to be distributed, provided or disclosed in any form to any party not involved in the audit, nor is such information to be used for any other purpose.

FILED - Missouri Public Service Commission - 05/01/2024 - TN-2024-0278 - JI-2024-0140

ACCESS SERVICE

23. ETHERNET SERVICE

23.1 AT&T SWITCHED ETHERNET SERVICESM

For service description, terms and conditions, and pricing, please see AT&T Switched Ethernet Service described in the AT&T Ethernet Service Guide found at the following website:

<https://cpr.att.com/pdf/commonEthServGuide.html>

Material from page 2 through page 35 is hereby deleted in its entirety and the pages are withdrawn from this Tariff.

FILED - Missouri Public Service Commission - 05/01/2024 - TN-2024-0278 - JI-2024-0140

P.S.C. Mo. - No. 36
ACCESS SERVICES TARIFF

Southwestern Bell Telephone Company, LLC
d/b/a **AT&T Missouri**

Section 23
2nd Revised Sheet 2
Replacing 1st Revised Sheet 2

ACCESS SERVICE

FILED - Missouri Public Service Commission - 05/01/2024 - TN-2024-0278 - JI-2024-0140

Issued: April 1, 2024

Effective: May 1, 2024

By Craig Unruh, President - Missouri
St. Louis, Missouri

P.S.C. Mo. - No. 36
ACCESS SERVICES TARIFF

Southwestern Bell Telephone Company, LLC
d/b/a AT&T Missouri

Section 23
2nd Revised Sheet 3
Replacing 1st Revised Sheet 3

ACCESS SERVICE

FILED - Missouri Public Service Commission - 05/01/2024 - TN-2024-0278 - JI-2024-0140

Issued: April 1, 2024

Effective: May 1, 2024

By Craig Unruh, President - Missouri
St. Louis, Missouri

**P.S.C. Mo. - No. 36
ACCESS SERVICES TARIFF**

Southwestern Bell Telephone Company, LLC
d/b/a AT&T Missouri

Section 23
4th Revised Sheet 4
Replacing 3rd Revised Sheet 4

ACCESS SERVICE

FILED - Missouri Public Service Commission - 05/01/2024 - TN-2024-0278 - JI-2024-0140

P.S.C. Mo. - No. 36
ACCESS SERVICES TARIFF

Southwestern Bell Telephone Company, LLC
d/b/a **AT&T Missouri**

Section 23
2nd Revised Sheet 5
Replacing 1st Revised Sheet 5

ACCESS SERVICE

FILED - Missouri Public Service Commission - 05/01/2024 - TN-2024-0278 - JI-2024-0140

Issued: April 1, 2024

Effective: May 1, 2024

By Craig Unruh, President - Missouri

St. Louis, Missouri

P.S.C. Mo. - No. 36
ACCESS SERVICES TARIFF

Southwestern Bell Telephone Company, LLC
d/b/a **AT&T Missouri**

Section 23
2nd Revised Sheet 6
Replacing 1st Revised Sheet 6

ACCESS SERVICE

FILED - Missouri Public Service Commission - 05/01/2024 - TN-2024-0278 - JI-2024-0140

Issued: April 1, 2024

Effective: May 1, 2024

By Craig Unruh, President - Missouri
St. Louis, Missouri

**P.S.C. Mo. - No. 36
ACCESS SERVICES TARIFF**

Southwestern Bell Telephone Company, LLC
d/b/a AT&T Missouri

Section 23
3rd Revised Sheet 7
Replacing 2nd Revised Sheet 7

ACCESS SERVICE

FILED - Missouri Public Service Commission - 05/01/2024 - TN-2024-0278 - JI-2024-0140

Issued: April 1, 2024

Effective: May 1, 2024

By Craig Unruh, President - Missouri
St. Louis, Missouri

P.S.C. Mo. - No. 36
ACCESS SERVICES TARIFF

Southwestern Bell Telephone Company, LLC
d/b/a **AT&T Missouri**

Section 23
3rd Revised Sheet 8
Replacing 2nd Revised Sheet 8

ACCESS SERVICE

FILED - Missouri Public Service Commission - 05/01/2024 - TN-2024-0278 - JI-2024-0140

Issued: April 1, 2024

Effective: May 1, 2024

By Craig Unruh, President - Missouri
St. Louis, Missouri

P.S.C. Mo. - No. 36
ACCESS SERVICES TARIFF

Southwestern Bell Telephone Company, LLC
d/b/a **AT&T Missouri**

Section 23
2nd Revised Sheet 9
Replacing 1st Revised Sheet 9

ACCESS SERVICE

FILED - Missouri Public Service Commission - 05/01/2024 - TN-2024-0278 - JI-2024-0140

Issued: April 1, 2024

Effective: May 1, 2024

By Craig Unruh, President - Missouri
St. Louis, Missouri

**P.S.C. Mo. - No. 36
ACCESS SERVICES TARIFF**

Southwestern Bell Telephone Company, LLC
d/b/a AT&T Missouri

Section 23
3rd Revised Sheet 10
Replacing 2nd Revised Sheet 10

ACCESS SERVICE

FILED - Missouri Public Service Commission - 05/01/2024 - TN-2024-0278 - JI-2024-0140

Issued: April 1, 2024

Effective: May 1, 2024

By Craig Unruh, President - Missouri
St. Louis, Missouri

**P.S.C. Mo. - No. 36
ACCESS SERVICES TARIFF**

Southwestern Bell Telephone Company, LLC
d/b/a AT&T Missouri

Section 23
2nd Revised Sheet 10.1
Replacing 1st Revised Sheet 10.1

ACCESS SERVICE

FILED - Missouri Public Service Commission - 05/01/2024 - TN-2024-0278 - JI-2024-0140

Issued: April 1, 2024

By Craig Unruh, President - Missouri
St. Louis, Missouri

Effective: May 1, 2024

P.S.C. Mo. - No. 36
ACCESS SERVICES TARIFF

Southwestern Bell Telephone Company, LLC
d/b/a **AT&T Missouri**

Section 23
2nd Revised Sheet 11
Replacing 1st Revised Sheet 11

ACCESS SERVICE

FILED - Missouri Public Service Commission - 05/01/2024 - TN-2024-0278 - JI-2024-0140

Issued: April 1, 2024

Effective: May 1, 2024

By Craig Unruh, President - Missouri
St. Louis, Missouri

P.S.C. Mo. - No. 36
ACCESS SERVICES TARIFF

Southwestern Bell Telephone Company, LLC
d/b/a **AT&T Missouri**

Section 23
2nd Revised Sheet 12
Replacing 1st Revised Sheet 12

ACCESS SERVICE

FILED - Missouri Public Service Commission - 05/01/2024 - TN-2024-0278 - JI-2024-0140

Issued: April 1, 2024

Effective: May 1, 2024

By Craig Unruh, President - Missouri
St. Louis, Missouri

P.S.C. Mo. - No. 36
ACCESS SERVICES TARIFF

Southwestern Bell Telephone Company, LLC
d/b/a **AT&T Missouri**

Section 23
2nd Revised Sheet 13
Replacing 1st Revised Sheet 13

ACCESS SERVICE

FILED - Missouri Public Service Commission - 05/01/2024 - TN-2024-0278 - JI-2024-0140

Issued: April 1, 2024

Effective: May 1, 2024

By Craig Unruh, President - Missouri
St. Louis, Missouri

P.S.C. Mo. - No. 36
ACCESS SERVICES TARIFF

Southwestern Bell Telephone Company, LLC
d/b/a **AT&T Missouri**

Section 23
2nd Revised Sheet 14
Replacing 1st Revised Sheet 14

ACCESS SERVICE

FILED - Missouri Public Service Commission - 05/01/2024 - TN-2024-0278 - JI-2024-0140

Issued: April 1, 2024

Effective: May 1, 2024

By Craig Unruh, President - Missouri
St. Louis, Missouri

P.S.C. Mo. - No. 36
ACCESS SERVICES TARIFF

Southwestern Bell Telephone Company, LLC
d/b/a **AT&T Missouri**

Section 23
2nd Revised Sheet 15
Replacing 1st Revised Sheet 15

ACCESS SERVICE

FILED - Missouri Public Service Commission - 05/01/2024 - TN-2024-0278 - JI-2024-0140

Issued: April 1, 2024

Effective: May 1, 2024

By Craig Unruh, President - Missouri
St. Louis, Missouri

P.S.C. Mo. - No. 36
ACCESS SERVICES TARIFF

Southwestern Bell Telephone Company, LLC
d/b/a **AT&T Missouri**

Section 23
2nd Revised Sheet 16
Replacing 1st Revised Sheet 16

ACCESS SERVICE

FILED - Missouri Public Service Commission - 05/01/2024 - TN-2024-0278 - JI-2024-0140

Issued: April 1, 2024

Effective: May 1, 2024

By Craig Unruh, President - Missouri
St. Louis, Missouri

P.S.C. Mo. - No. 36
ACCESS SERVICES TARIFF

Southwestern Bell Telephone Company, LLC
d/b/a **AT&T Missouri**

Section 23
2nd Revised Sheet 17
Replacing 1st Revised Sheet 17

ACCESS SERVICE

FILED - Missouri Public Service Commission - 05/01/2024 - TN-2024-0278 - JI-2024-0140

Issued: April 1, 2024

Effective: May 1, 2024

By Craig Unruh, President - Missouri
St. Louis, Missouri

P.S.C. Mo. - No. 36
ACCESS SERVICES TARIFF

Southwestern Bell Telephone Company, LLC
d/b/a **AT&T Missouri**

Section 23
2nd Revised Sheet 18
Replacing 1st Revised Sheet 18

ACCESS SERVICE

FILED - Missouri Public Service Commission - 05/01/2024 - TN-2024-0278 - JI-2024-0140

Issued: April 1, 2024

Effective: May 1, 2024

By Craig Unruh, President - Missouri
St. Louis, Missouri

P.S.C. Mo. - No. 36
ACCESS SERVICES TARIFF

Southwestern Bell Telephone Company, LLC
d/b/a **AT&T Missouri**

Section 23
2nd Revised Sheet 19
Replacing 1st Revised Sheet 19

ACCESS SERVICE

FILED - Missouri Public Service Commission - 05/01/2024 - TN-2024-0278 - JI-2024-0140

Issued: April 1, 2024

Effective: May 1, 2024

By Craig Unruh, President - Missouri
St. Louis, Missouri

P.S.C. Mo. - No. 36
ACCESS SERVICES TARIFF

Southwestern Bell Telephone Company, LLC
d/b/a **AT&T Missouri**

Section 23
3rd Revised Sheet 20
Replacing 2nd Revised Sheet 20

ACCESS SERVICE

FILED - Missouri Public Service Commission - 05/01/2024 - TN-2024-0278 - JI-2024-0140

Issued: April 1, 2024

Effective: May 1, 2024

By Craig Unruh, President - Missouri
St. Louis, Missouri

P.S.C. Mo. - No. 36
ACCESS SERVICES TARIFF

Southwestern Bell Telephone Company, LLC
d/b/a **AT&T Missouri**

Section 23
2nd Revised Sheet 21
Replacing 1st Revised Sheet 21

ACCESS SERVICE

FILED - Missouri Public Service Commission - 05/01/2024 - TN-2024-0278 - JI-2024-0140

Issued: April 1, 2024

Effective: May 1, 2024

By Craig Unruh, President - Missouri
St. Louis, Missouri

P.S.C. Mo. - No. 36
ACCESS SERVICES TARIFF

Southwestern Bell Telephone Company, LLC
d/b/a **AT&T Missouri**

Section 23
3rd Revised Sheet 22
Replacing 2nd Revised Sheet 22

ACCESS SERVICE

FILED - Missouri Public Service Commission - 05/01/2024 - TN-2024-0278 - JI-2024-0140

Issued: April 1, 2024

Effective: May 1, 2024

By Craig Unruh, President - Missouri
St. Louis, Missouri

P.S.C. Mo. - No. 36
ACCESS SERVICES TARIFF

Southwestern Bell Telephone Company, LLC
d/b/a **AT&T Missouri**

Section 23
4th Revised Sheet 23
Replacing 3rd Revised Sheet 23

ACCESS SERVICE

FILED - Missouri Public Service Commission - 05/01/2024 - TN-2024-0278 - JI-2024-0140

Issued: April 1, 2024

Effective: May 1, 2024

By Craig Unruh, President - Missouri
St. Louis, Missouri

P.S.C. Mo. - No. 36
ACCESS SERVICES TARIFF

Southwestern Bell Telephone Company, LLC
d/b/a **AT&T Missouri**

Section 23
4th Revised Sheet 24
Replacing 3rd Revised Sheet 24

ACCESS SERVICE

FILED - Missouri Public Service Commission - 05/01/2024 - TN-2024-0278 - JI-2024-0140

Issued: April 1, 2024

Effective: May 1, 2024

By Craig Unruh, President - Missouri
St. Louis, Missouri

P.S.C. Mo. - No. 36
ACCESS SERVICES TARIFF

Southwestern Bell Telephone Company, LLC
d/b/a **AT&T Missouri**

Section 23
4th Revised Sheet 25
Replacing 3rd Revised Sheet 25

ACCESS SERVICE

FILED - Missouri Public Service Commission - 05/01/2024 - TN-2024-0278 - JI-2024-0140

Issued: April 1, 2024

Effective: May 1, 2024

By Craig Unruh, President - Missouri
St. Louis, Missouri

P.S.C. Mo. - No. 36
ACCESS SERVICES TARIFF

Southwestern Bell Telephone Company, LLC
d/b/a **AT&T Missouri**

Section 23
4th Revised Sheet 26
Replacing 3rd Revised Sheet 26

ACCESS SERVICE

FILED - Missouri Public Service Commission - 05/01/2024 - TN-2024-0278 - JI-2024-0140

Issued: April 1, 2024

Effective: May 1, 2024

By Craig Unruh, President - Missouri
St. Louis, Missouri

P.S.C. Mo. - No. 36
ACCESS SERVICES TARIFF

Southwestern Bell Telephone Company, LLC
d/b/a **AT&T Missouri**

Section 23
4th Revised Sheet 27
Replacing 3rd Revised Sheet 27

ACCESS SERVICE

FILED - Missouri Public Service Commission - 05/01/2024 - TN-2024-0278 - JI-2024-0140

Issued: April 1, 2024

Effective: May 1, 2024

By Craig Unruh, President - Missouri
St. Louis, Missouri

P.S.C. Mo. - No. 36
ACCESS SERVICES TARIFF

Southwestern Bell Telephone Company, LLC
d/b/a **AT&T Missouri**

Section 23
3rd Revised Sheet 28
Replacing 2nd Revised Sheet 28

ACCESS SERVICE

FILED - Missouri Public Service Commission - 05/01/2024 - TN-2024-0278 - JI-2024-0140

Issued: April 1, 2024

Effective: May 1, 2024

By Craig Unruh, President - Missouri
St. Louis, Missouri

P.S.C. Mo. - No. 36
ACCESS SERVICES TARIFF

Southwestern Bell Telephone Company, LLC
d/b/a **AT&T Missouri**

Section 23
4th Revised Sheet 29
Replacing 3rd Revised Sheet 29

ACCESS SERVICE

FILED - Missouri Public Service Commission - 05/01/2024 - TN-2024-0278 - JI-2024-0140

Issued: April 1, 2024

Effective: May 1, 2024

By Craig Unruh, President - Missouri
St. Louis, Missouri

P.S.C. Mo. - No. 36
ACCESS SERVICES TARIFF

Southwestern Bell Telephone Company, LLC
d/b/a **AT&T Missouri**

Section 23
4th Revised Sheet 30
Replacing 3rd Revised Sheet 30

ACCESS SERVICE

FILED - Missouri Public Service Commission - 05/01/2024 - TN-2024-0278 - JI-2024-0140

Issued: April 1, 2024

Effective: May 1, 2024

By Craig Unruh, President - Missouri
St. Louis, Missouri

P.S.C. Mo. - No. 36
ACCESS SERVICES TARIFF

Southwestern Bell Telephone Company, LLC
d/b/a **AT&T Missouri**

Section 23
4th Revised Sheet 31
Replacing 3rd Revised Sheet 31

ACCESS SERVICE

FILED - Missouri Public Service Commission - 05/01/2024 - TN-2024-0278 - JI-2024-0140

Issued: April 1, 2024

Effective: May 1, 2024

By Craig Unruh, President - Missouri
St. Louis, Missouri

P.S.C. Mo. - No. 36
ACCESS SERVICES TARIFF

Southwestern Bell Telephone Company, LLC
d/b/a **AT&T Missouri**

Section 23
4th Revised Sheet 32
Replacing 3rd Revised Sheet 32

ACCESS SERVICE

FILED - Missouri Public Service Commission - 05/01/2024 - TN-2024-0278 - JI-2024-0140

Issued: April 1, 2024

Effective: May 1, 2024

By Craig Unruh, President - Missouri
St. Louis, Missouri

P.S.C. Mo. - No. 36
ACCESS SERVICES TARIFF

Southwestern Bell Telephone Company, LLC
d/b/a **AT&T Missouri**

Section 23
2nd Revised Sheet 33
Replacing 1st Revised Sheet 33

ACCESS SERVICE

FILED - Missouri Public Service Commission - 05/01/2024 - TN-2024-0278 - JI-2024-0140

Issued: April 1, 2024

Effective: May 1, 2024

By Craig Unruh, President - Missouri
St. Louis, Missouri

P.S.C. Mo. - No. 36
ACCESS SERVICES TARIFF

Southwestern Bell Telephone Company, LLC
d/b/a **AT&T Missouri**

Section 23
2nd Revised Sheet 34
Replacing 1st Revised Sheet 34

ACCESS SERVICE

FILED - Missouri Public Service Commission - 05/01/2024 - TN-2024-0278 - JI-2024-0140

Issued: April 1, 2024

Effective: May 1, 2024

By Craig Unruh, President - Missouri
St. Louis, Missouri

P.S.C. Mo. - No. 36
ACCESS SERVICES TARIFF

Southwestern Bell Telephone Company, LLC
d/b/a **AT&T Missouri**

Section 23
2nd Revised Sheet 35
Replacing 1st Revised Sheet 35

ACCESS SERVICE

FILED - Missouri Public Service Commission - 05/01/2024 - TN-2024-0278 - JI-2024-0140

Issued: April 1, 2024

Effective: May 1, 2024

By Craig Unruh, President - Missouri
St. Louis, Missouri

ACCESS SERVICE

23.2 AT&T DEDICATED ETHERNET SERVICE

23.2.1 Service Description

For service description, terms and conditions, and pricing, please see AT&T Dedicated Ethernet Service described in the AT&T Ethernet Service Guide found at the following website:

<https://cpr.att.com/pdf/commonEthServGuide.html>

Material from Page 37 through Page 52 is hereby deleted in its entirety.

FILED - Missouri Public Service Commission - 05/01/2024 - TN-2024-0278 - JI-2024-0140

**P.S.C. Mo. - No. 36
ACCESS SERVICES TARIFF**

Southwestern Bell Telephone Company, LLC
d/b/a AT&T Missouri

Section 23
2nd Revised Sheet 37
Replacing 1st Revised Sheet 37

ACCESS SERVICE

FILED - Missouri Public Service Commission - 05/01/2024 - TN-2024-0278 - JI-2024-0140

Issued: April 1, 2024

By Craig Unruh, President - Missouri
St. Louis, Missouri

Effective: May 1, 2024

**P.S.C. Mo. - No. 36
ACCESS SERVICES TARIFF**

Southwestern Bell Telephone Company, LLC
d/b/a AT&T Missouri
Replacing 1st Revised Sheet 37.1

Section 23
2nd Revised Sheet 37.1

ACCESS SERVICE

FILED - Missouri Public Service Commission - 05/01/2024 - TN-2024-0278 - JI-2024-0140

Issued: April 1, 2024

By Craig Unruh, President - Missouri
St. Louis, Missouri

Effective: May 1, 2024

**P.S.C. Mo. - No. 36
ACCESS SERVICES TARIFF**

Southwestern Bell Telephone Company, LLC
d/b/a AT&T Missouri

Section 23
2nd Revised Sheet 37.2
Replacing 1st Revised Sheet 37.2

ACCESS SERVICE

FILED - Missouri Public Service Commission - 05/01/2024 - TN-2024-0278 - JI-2024-0140

Issued: April 1, 2024

By Craig Unruh, President - Missouri
St. Louis, Missouri

Effective: May 1, 2024

**P.S.C. Mo. - No. 36
ACCESS SERVICES TARIFF**

Southwestern Bell Telephone Company, LLC
d/b/a AT&T Missouri

Section 23
3rd Revised Sheet 38
Replacing 2nd Revised Sheet 38

ACCESS SERVICE

FILED - Missouri Public Service Commission - 05/01/2024 - TN-2024-0278 - JI-2024-0140

Issued: April 1, 2024

By Craig Unruh, President - Missouri
St. Louis, Missouri

Effective: May 1, 2024

**P.S.C. Mo. - No. 36
ACCESS SERVICES TARIFF**

Southwestern Bell Telephone Company, LLC
d/b/a AT&T Missouri

Section 23
3rd Revised Sheet 39
Replacing 2nd Revised Sheet 39

ACCESS SERVICE

FILED - Missouri Public Service Commission - 05/01/2024 - TN-2024-0278 - JI-2024-0140

Issued: April 1, 2024

By Craig Unruh, President - Missouri
St. Louis, Missouri

Effective: May 1, 2024

**P.S.C. Mo. - No. 36
ACCESS SERVICES TARIFF**

Southwestern Bell Telephone Company, LLC
d/b/a AT&T Missouri

Section 23
3rd Revised Sheet 40
Replacing 2nd Revised Sheet 40

ACCESS SERVICE

FILED - Missouri Public Service Commission - 05/01/2024 - TN-2024-0278 - JI-2024-0140

Issued: April 1, 2024

By Craig Unruh, President - Missouri
St. Louis, Missouri

Effective: May 1, 2024

**P.S.C. Mo. - No. 36
ACCESS SERVICES TARIFF**

Southwestern Bell Telephone Company, LLC
d/b/a AT&T Missouri

Section 23
3rd Revised Sheet 41
Replacing 2nd Revised Sheet 41

ACCESS SERVICE

FILED - Missouri Public Service Commission - 05/01/2024 - TN-2024-0278 - JI-2024-0140

Issued: April 1, 2024

By Craig Unruh, President - Missouri
St. Louis, Missouri

Effective: May 1, 2024

**P.S.C. Mo. - No. 36
ACCESS SERVICES TARIFF**

Southwestern Bell Telephone Company, LLC
d/b/a AT&T Missouri

Section 23
2nd Revised Sheet 42
Replacing 1st Revised Sheet 42

ACCESS SERVICES

FILED - Missouri Public Service Commission - 05/01/2024 - TN-2024-0278 - JI-2024-0140

Issued: April 1, 2024

By Craig Unruh, President - Missouri
St. Louis, Missouri

Effective: May 1, 2024

**P.S.C. Mo. - No. 36
ACCESS SERVICES TARIFF**

Southwestern Bell Telephone Company, LLC
d/b/a AT&T Missouri

Section 23
3rd Revised Sheet 43
Replacing 2nd Revised Sheet 43

ACCESS SERVICES

FILED - Missouri Public Service Commission - 05/01/2024 - TN-2024-0278 - JI-2024-0140

Issued: April 1, 2024

By Craig Unruh, President - Missouri
St. Louis, Missouri

Effective: May 1, 2024

**P.S.C. Mo. - No. 36
ACCESS SERVICES TARIFF**

Southwestern Bell Telephone Company, LLC
d/b/a AT&T Missouri

Section 23
5th Revised Sheet 44
Replacing 4th Revised Sheet 44

ACCESS SERVICES

FILED - Missouri Public Service Commission - 05/01/2024 - TN-2024-0278 - JI-2024-0140

Issued: April 1, 2024

By Craig Unruh, President - Missouri
St. Louis, Missouri

Effective: May 1, 2024

**P.S.C. Mo. - No. 36
ACCESS SERVICES TARIFF**

Southwestern Bell Telephone Company, LLC
d/b/a AT&T Missouri

Section 23
2nd Revised Sheet 45
Replacing 1st Revised Sheet 45

ACCESS SERVICES

FILED - Missouri Public Service Commission - 05/01/2024 - TN-2024-0278 - JI-2024-0140

Issued: April 1, 2024

By Craig Unruh, President - Missouri
St. Louis, Missouri

Effective: May 1, 2024

**P.S.C. Mo. - No. 36
ACCESS SERVICES TARIFF**

Southwestern Bell Telephone Company, LLC
d/b/a AT&T Missouri

Section 23
2nd Revised Sheet 46
Replacing 1st Revised Sheet 46

ACCESS SERVICES

FILED - Missouri Public Service Commission - 05/01/2024 - TN-2024-0278 - JI-2024-0140

Issued: April 1, 2024

By Craig Unruh, President - Missouri
St. Louis, Missouri

Effective: May 1, 2024

**P.S.C. Mo. - No. 36
ACCESS SERVICES TARIFF**

Southwestern Bell Telephone Company, LLC
d/b/a AT&T Missouri

Section 23
3rd Revised Sheet 47
Replacing 2nd Revised Sheet 47

ACCESS SERVICES

FILED - Missouri Public Service Commission - 05/01/2024 - TN-2024-0278 - JI-2024-0140

Issued: April 1, 2024

By Craig Unruh, President - Missouri
St. Louis, Missouri

Effective: May 1, 2024

**P.S.C. Mo. - No. 36
ACCESS SERVICES TARIFF**

Southwestern Bell Telephone Company, LLC
d/b/a AT&T Missouri

Section 23
2nd Revised Sheet 48
Replacing 1st Revised Sheet 48

ACCESS SERVICE

FILED - Missouri Public Service Commission - 05/01/2024 - TN-2024-0278 - JI-2024-0140

Issued: April 1, 2024

By Craig Unruh, President - Missouri
St. Louis, Missouri

Effective: May 1, 2024

**P.S.C. Mo. - No. 36
ACCESS SERVICES TARIFF**

Southwestern Bell Telephone Company, LLC
d/b/a AT&T Missouri

Section 23
2nd Revised Sheet 49
Replacing 1st Revised Sheet 49

ACCESS SERVICES

FILED - Missouri Public Service Commission - 05/01/2024 - TN-2024-0278 - JI-2024-0140

Issued: April 1, 2024

By Craig Unruh, President - Missouri
St. Louis, Missouri

Effective: May 1, 2024

**P.S.C. Mo. - No. 36
ACCESS SERVICES TARIFF**

Southwestern Bell Telephone Company, LLC
d/b/a AT&T Missouri

Section 23
2nd Revised Sheet 50
Replacing 1st Revised Sheet 50

ACCESS SERVICE

FILED - Missouri Public Service Commission - 05/01/2024 - TN-2024-0278 - JI-2024-0140

Issued: April 1, 2024

By Craig Unruh, President - Missouri
St. Louis, Missouri

Effective: May 1, 2024

**P.S.C. Mo. - No. 36
ACCESS SERVICES TARIFF**

Southwestern Bell Telephone Company, LLC
d/b/a AT&T Missouri

Section 23
2nd Revised Sheet 51
Replacing 1st Revised Sheet 51

ACCESS SERVICES

FILED - Missouri Public Service Commission - 05/01/2024 - TN-2024-0278 - JI-2024-0140

Issued: April 1, 2024

By Craig Unruh, President - Missouri
St. Louis, Missouri

Effective: May 1, 2024

**P.S.C. Mo. - No. 36
ACCESS SERVICES TARIFF**

Southwestern Bell Telephone Company, LLC
d/b/a AT&T Missouri

Section 23
2nd Revised Sheet 52
Replacing 1st Revised Sheet 52

ACCESS SERVICE

FILED - Missouri Public Service Commission - 05/01/2024 - TN-2024-0278 - JI-2024-0140

Issued: April 1, 2024

By Craig Unruh, President - Missouri
St. Louis, Missouri

Effective: May 1, 2024

P.S.C. Mo. - No. 36
ACCESS SERVICES TARIFF

Southwestern Bell Telephone Company, LLC
d/b/a AT&T Missouri

Section 39
1st Revised Sheet 1
Replacing Original Sheet 1

ACCESS SERVICE

This section concurs in Southwestern Bell Telephone Company, LLC's (SWBT's) Tariff FCC No. 1, Section 39, (AT)(CT) which can be accessed via the following hypertext link to AT&T Missouri's commercial website:

<http://cpr.att.com/pdf/fcc-swbt/1039.pdf>

(CT)

Exceptions to this concurrence of Southwestern Bell Telephone Company, LLC's (SWBT's) Tariff FCC No. 1, Section 39, are as listed below. The following cited exceptions relate to that specific section in the interstate Tariff FCC No. 1.

(AT)(CT)

(CT)

39. Metropolitan Statistical Area Access Services

39.1 General Regulations

Special Access pricing flexibility is not available in the intrastate jurisdiction.

39.3 Services Available in an MSA

Special Access pricing flexibility is not available in the intrastate jurisdiction.

39.4 Rate Regulations

39.4(F) Term Pricing Plans

This section is not applicable to the intrastate jurisdiction.

39.5 Rates and Charges

39.5.2 Special Access

Special Access pricing flexibility is not available in the intrastate jurisdiction.

39.5.3 Access Order Charges

Pricing flexibility for Access Order Charges is not available in the intrastate jurisdiction.

39.5.4 Vintage Rates

Vintage Rates do not apply to the intrastate jurisdiction.

FILED - Missouri Public Service Commission - 05/01/2024 - TN-2024-0278 - JI-2024-0140